

Product Data

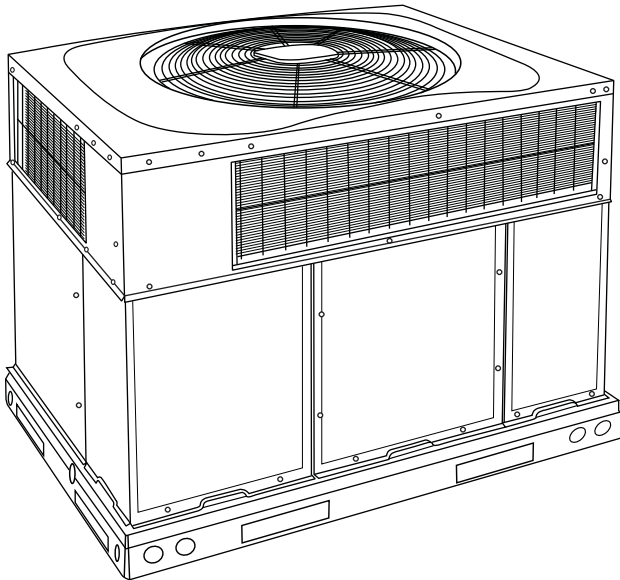

A09034

Fig. 1 - Unit 704D---A

Single-Packaged Products with Energy-Saving Features and Puron® refrigerant.

- Up to 13.5 SEER
- Factory-Installed TXV
- ECM Motor-Standard
- Low Sound Levels

FEATURES/BENEFITS

One-piece cooling unit with optional electric heater, low sound levels, easy installation, low maintenance, and dependable performance.

Puron Environmentally Sound Refrigerant is Bryant's unique refrigerant designed to help protect the environment. Puron is an HFC refrigerant which does not contain chlorine that can harm the ozone layer. Puron refrigerant is in service in millions of systems, proving highly reliable, environmentally sound performance.

Easy Installation

Factory-assembled package is a compact, fully self-contained, electric cooling unit that is prewired, pre-piped, and pre-charged for minimum installation expense. These units are available in a variety of standard cooling sizes with voltage options to meet residential and light commercial requirements. Units are lightweight and install easily on a rooftop or at ground level. The high tech composite base eliminates rust problems associated with ground level applications.

Innovative Unit Base Design

On the inside a high-tech composite material will not rust and incorporates a sloped drain pan which improves drainage and helps inhibit mold, algae and bacterial growth. On the outside metal base rails provide added stability as well as easier handling and rigging.

Convertible duct configuration

Unit is designed for use in either downflow or horizontal applications. Each unit can be converted from horizontal to

downflow and includes horizontal duct covers. Downflow operation is provided in the field to allow vertical ductwork connections. The basepan seals on the bottom openings to ensure a positive seal in the vertical airflow mode.

Efficient operation High-efficiency design offers SEER (Seasonal Energy Efficiency Ratios) of up to 13.5. (See page 3.)

Durable, dependable components

Scroll Compressors are designed for high efficiency. Each compressor is hermetically sealed against contamination to help promote longer life and dependable operation. Each compressor also has vibration isolation to provide quieter operation. All compressors have internal high pressure and overcurrent protection.

ECM Motor is standard on all 704D--A models.

Direct-drive PSC (Permanent Split Capacitor) condenser-fan motors are designed to help reduce energy consumption and provide for cooling operation down to 40°F (4.4°C) outdoor temperature. Motormaster® II low ambient kit is available as a field-installed accessory.

Thermostatic Expansion Valve - A hard shutoff, balance port TXV maintains a constant superheat at the evaporator exit (cooling cycle) resulting in higher overall system efficiency.

Refrigerant system is designed to provide dependability. Liquid filter driers are used to promote clean, unrestricted operation. Each unit leaves the factory with a full refrigerant charge. Refrigerant service connections make checking operating pressures easier.

High and Low Pressure Switches provide added reliability for the compressor.

Indoor and Outdoor coils are computer-designed for optimum heat transfer and efficiency. The indoor coil is fabricated from copper tube and aluminum fins and is located inside the unit for protection against damage. The outdoor coil is internally mounted on the top tier of the unit.

Low sound ratings ensure a quiet indoor and outdoor environment with sound ratings as low as 75dBA. (See Page 3.)

Easy to service cabinets provide easy 3-panel accessibility to serviceable components during maintenance and installation. The basepan with integrated drain pan provides easy ground level installation with a mounting pad. A nesting feature ensures a positive basepan to roof curb seal when the unit is roof mounted. A convenient 3/4-in. (19.1 mm) wide perimeter flange makes frame mounting on a rooftop easy.

Standard horizontal metal duct covers with insulation come with the unit and cover the horizontal duct openings. These can be left in place if the units are converted to downflow.

Cabinets are constructed of heavyduty, phosphated, zinc-coated prepainted steel capable of withstanding 500 hours in salt spray. Interior surfaces of the evaporator/heat exchanger compartment are insulated with cleanable semi-rigid insulation board, which keeps the conditioned air from being affected by the outdoor ambient temperature and provides improved indoor air quality. (Conforms to American Society of Heating, Refrigeration and Air Conditioning Engineers No. 62P.) The sloped drain pan minimizes standing water in the drain. An external drain is provided.

TABLE OF CONTENTS

FEATURES/BENEFITS 1
 MODEL NUMBER NOMENCLATURE 3
 AHRI CAPACITIES 4
 PHYSICAL DATA 5
 OPTIONS AND ACCESSORIES 6
 BASE UNIT DIMENSIONS 8-9
 ROOF CURB ACCESSORY 10
 SELECTION PROCEDURE 11
 PERFORMANCE DATA 12-21
 TYPICAL PIPING AND WIRING 22
 APPLICATION DATA 23
 ELECTRICAL DATA 24-25
 TYPICAL WIRING SCHEMATICS 26-31
 CONTROLS 32
 GUIDE SPECIFICATIONS 33-34

MODEL NUMBER NOMENCLATURE



Use of the AHRI Certified TM Mark indicates a manufacturer's participation in the program. For verification of certification for individual products, go to www.ahridirectory.org.

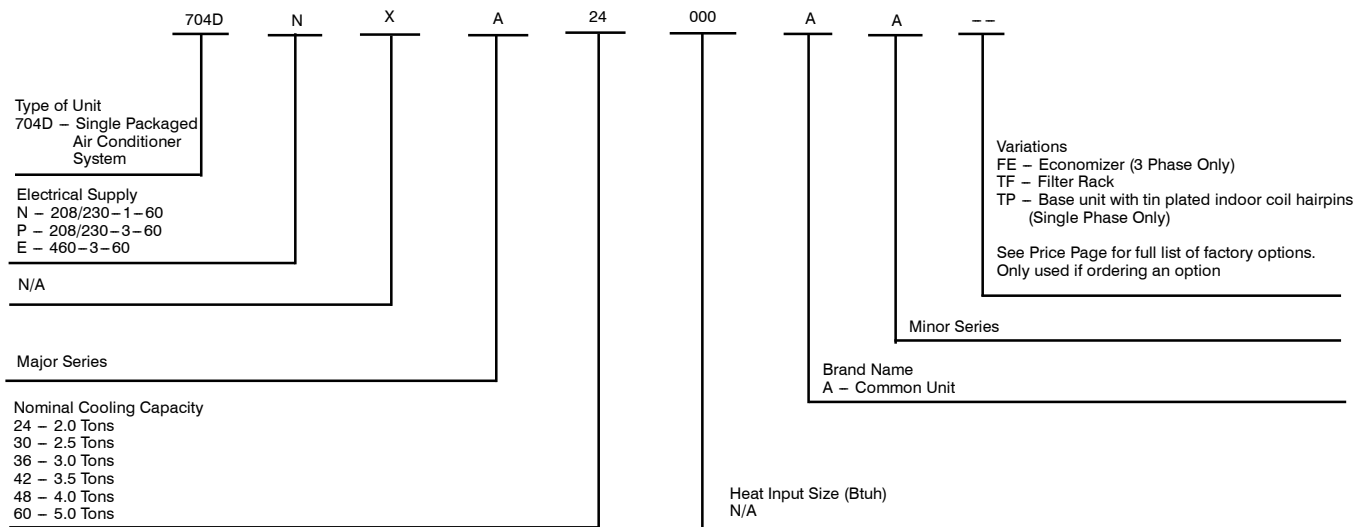

AHRI* CAPACITIES

Cooling Capacities and Efficiencies

UNIT 704D--A	NOMINAL TONS	STANDARD CFM	NET COOLING CAPACITIES (Btuh)	EER**	SEER†
24	2	800	23,000	11.0	13.2
30	2-1/2	1000	28,400	11.2	13.5
36	3	1200	34,400	11.0	13.0
42	3-1/2	1400	40,500	11.2	13.2
48	4	1600	46,500	11.2	13.2
60	5	1750	57,000	11.0	13.4

LEGEND

dB—Sound Levels (decibels)

db—Dry Bulb

SEER—Seasonal Energy Efficiency Ratio

wb—Wet Bulb

COP—Coefficient of Performance

* Air Conditioning, Heating & Refrigeration Institute.

**At "A" conditions—80°F (26.7°C) indoor db/67°F (19.4°C) indoor wb & 95°F (35°C) outdoor db.

† Rated in accordance with U.S. Government DOE (Department of Energy) test procedures and/or AHRI Standards 210/240.

Notes:

1. Ratings are net values, reflecting the effects of circulating fan heat. Ratings are based on:

Cooling Standard: 80°F (26.7°C) db, 67°F wb (19.4°C) indoor entering—air temperature and 95°F db (35°C) outdoor entering—air temperature.

2. Before purchasing this appliance, read important energy cost and efficiency information available from your retailer.

704D--A

A-Weighted Sound Power Level (dBA)

UNIT 704D--A	STANDARD RATING (dBA)	TYPICAL OCTAVE BAND SPECTRUM (dBA without tone adjustment)						
		125	250	500	1000	2000	4000	8000
24	76	66.0	66.0	70.5	71.5	67.5	62.5	58.5
30	75	66.0	63.5	68.0	68.5	67.5	61.5	55.0
36	75	64.0	63.5	68.0	70.5	64.5	61.0	61.0
42	77	67.0	67.0	69.5	70.5	68.0	65.5	61.0
48	78	71.5	66.5	73.0	71.5	68.0	64.0	57.0
60	78	74.5	66.5	70.0	70.0	66.5	64.0	57.0

* Tested in accordance with AHRI Standard 270 (not listed in AHRI) physical data.

Physical Data-Unit 704D--A

UNIT SIZE	24	30	36	42	48	60
NOMINAL CAPACITY (ton)	2	2-1/2	3	3-1/2	4	5
SHIPPING WEIGHT* lb.	279	284	290	378	384	406
SHIPPING WEIGHT* (kg)	127	129	132	171	174	184
COMPRESSORS	Scroll					
Quantity	1					
REFRIGERANT (R-410A)						
Quantity lb	4.8	6.2	6.4	6.1	6.4	10.0
Quantity (kg)	2.2	2.8	2.9	2.7	2.9	4.5
REFRIGERANT METERING DEVICE	TXV					
OUTDOOR COIL						
Rows...Fins/in.	1...21	1...21	1...21	1...21	1...21	2...21
Face Area (sq ft)	10.2	11.9	15.4	13.6	15.5	15.5
OUTDOOR FAN						
Nominal Cfm	2800	3000	3200	3600	4000	3200
Diameter in.	24	24	24	26	26	26
Diameter (mm)	610	610	610	660	660	660
Motor Hp (Rpm)	1/5 (810)	1/5 (810)	1/5 (810)	1/5 (810)	1/5 (810)	1/5 (810)
INDOOR COIL						
Rows...Fins/in.	2...17	3...17	3...17	3...17	3...17	3...17
Face Area (sq ft)	3.7	3.7	3.7	4.7	4.7	5.7
INDOOR BLOWER						
Nominal Cooling Airflow (Cfm)	800	1000	1200	1400	1600	1750
Size in.	10x10	10x10	11x10	11x10	11x10	11x10
Size (mm.)	254x254	254x254	279.4x254	279.4x254	279.4x254	279.4x254
Motor HP (RPM)	1/2 (1050)	1/2 (1050)	3/4 (1000)	3/4 (1075)	1.0 (1075)	1.0 (1040)
HIGH-PRESSURE SWITCH (psig) Cut-out Reset (Auto)	650 +/- 15 420 +/- 25					
LOSS-OF-CHARGE / LOW-PRES-SURE SWITCH (Liquid Line) (psig) cut-out Reset (auto)	20 +/- 5 45 +/- 10					
RETURN-AIR FILTERS†‡						
Throwaway Size in.	20x20x1	20x24x1	24x30x1	24x36x1		
Throwaway Size (mm)	508x508x25	508x610x25	610x762x25	610x914x25		

*For 460 volt units add 14 lb (6.35 kg) to the shipping weight.

† Required filter sizes shown are based on the larger of the AHRI (Air Conditioning, Heating and Refrigeration Institute) rated cooling airflow or the heating airflow velocity of 300 ft/minute for throwaway type or 450 ft/minute for high-capacity type. Air filter pressure drop for non-standard filters must not exceed 0.08 in. W.C.

‡ If using accessory filter rack refer to the filter rack installation instructions for correct filter sizes and quantity.

704D--A

OPTIONS AND ACCESSORIES

ITEM	DESCRIPTION	FACTORY INSTALLED OPTION	FIELD INSTALLED ACCESSORY
Coil Options	Base unit with tin plated indoor coil hairpins	X	
Compressor Start Kit	Compressor Start Kit assists compressor start-up by providing additional starting torque on single phase units only.		X
Corporate Thermostats	Thermostats provide control for the system heating and cooling functions.		X
Crankcase Heater	Crankcase Heater provides anti-floodback protection for low-load cooling applications.		X*
Economizer	Horizontal Economizer with solid state controls and barometric relief dampers includes filter racks and provide outdoor air during cooling and reduce compressor operation.		X
	Vertical Economizer with solid state controls and barometric relief dampers includes filter racks and provide outdoor air during cooling and reduce compressor operation.	X	X
Electric Heaters	Electric Heat Supplement		X
Filter Rack	Filter Rack features easy installation, serviceability, and high-filtering performance for vertical applications. Includes 1-in. (25 mm) filter.	X	X
Flat Roof Curbs	Flat Roof Curbs in both 11-in (279 mm) and 14-in. (356 mm) sizes are available for roof mounted applications.		X
Low Ambient Kit	Low Ambient Kit (Motormaster II Control) allows the use of mechanical cooling down to outdoor temperatures as low as 0°F (-18°C) when properly installed.		X
Louver Metal Outdoor Coil Grilles	Louver Metal Outdoor Coil Grilles provides hail and vandalism protection.		X
Manual Outside Air Damper	Manual Outside Air Damper includes hood and filter rack with adjustable damper blade for up to 25% outdoor air.		X
Square-to-Round Duct Transition Kit	Square-to-Round Duct Transition Kit enable 24-48 size units to be fitted to 14 in. (356 mm) round ductwork.		X
Time Guard II	Automatically prevents the compressor from restarting for at least 4 minutes and 45 seconds after shutdown of the compressor. Not required when a corporate programmable thermostat is applied or with a RTU-MP control.		X
Curb Adapter	Adapter curb for new unit with base rail installed on existing curb		X
Gasket Kit	For field modified existing roof curb with new base rail unit.		X
Dual Point Kit	Allows you to power the electric heater and unit contactor separately by having two individual field power supply circuits connected respectively.		X

*Refer to Price Page for application detail.

704D--A

Electric Heaters

CATALOG ORDERING NO.	NOMINAL CAPACITY (kW)	FUSE QTY	USED WITH SIZES					
			24	30	36	42	48	60
ELECTRIC HEATERS (208/230 — SINGLE PHASE — 60 Hz)								
CPHEATER052A00	5.0	—	X	X	X	X	X	X
CPHEATER064A00	5.0	4	X	X	X	X	X	X
CPHEATER069A00	7.2	—	X	X	X	X	X	X
CPHEATER070A00	7.2	4	X	X	X	X	X	X
CPHEATER065A00	10.0	—	X	X	X	X		
CPHEATER050A00	10.0	4	X	X	X	X	X	X
CPHEATER051A00	15.0	4		X	X	X		
CPHEATER066A00	15.0	6		X	X	X	X	X
CPHEATER053A00	20.0	4				X	X	X
CPHEATER054A00	20.0	6				X	X	X
ELECTRIC HEATERS (208/230 — THREE PHASE — 60 Hz)								
CPHEATER055A00	5.0	—		X	X	X	X	X
CPHEATER056A00	10.0	—		X	X	X	X	X
CPHEATER068A00	10.0	6		X	X	X	X	X
CPHEATER057A00	15.0	—		X	X	X	X	X
CPHEATER058A00	15.0	6		X	X	X	X	X
CPHEATER059A01	20.0	6				X	X	X
ELECTRIC HEATERS (460 — THREE PHASE — 60 Hz)								
CPHEATER060A00	5.0	—			X	X	X	X
CPHEATER061A00	10.0	—			X	X	X	X
CPHEATER062A00	15.0	—			X	X	X	X
CPHEATER063A00	20.0	—				X	X	X

NOTE: Electric heaters are rated at 240v. Refer to Multiplication Factors table for other voltages.

X = Approved combinations.

Minimum Airflow for Safe Electric Heater Operation (CFM)

SIZE	24	30	36	42	48	60
Cfm	800	1000	1200	1400	1600	1750

ECONOMIZER

704D--A

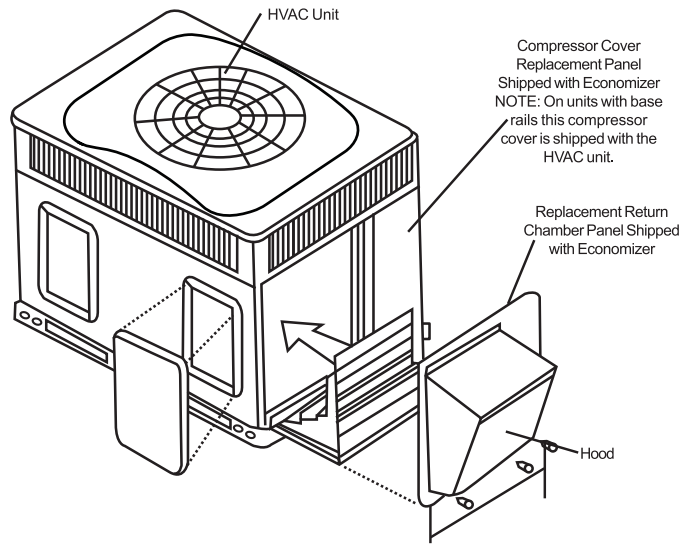
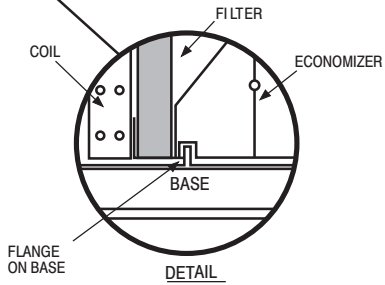
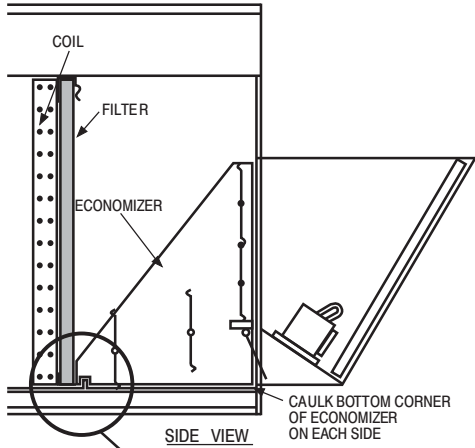

Vertical Economizer

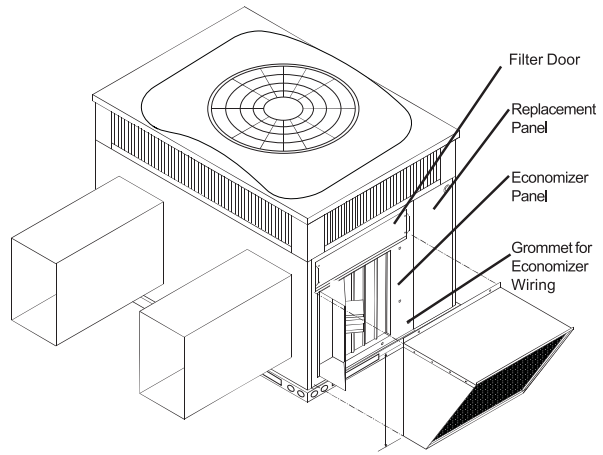

Horizontal Economizer

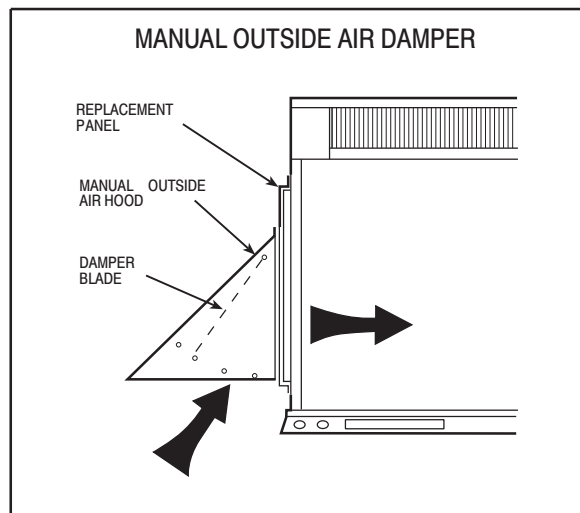
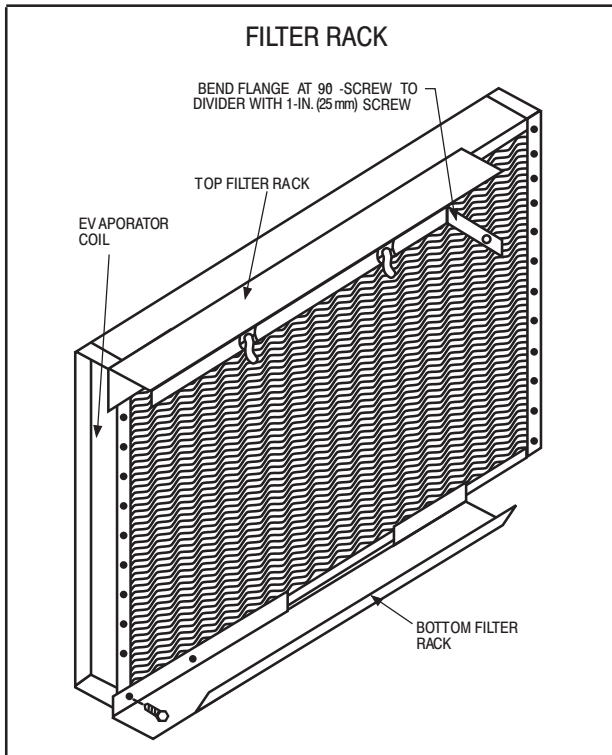

A09375

UNIT DIMENSIONS - 704D--A24-36

UNIT	ELECTRICAL CHARACTERISTICS	UNIT WT.		UNIT HEIGHT "A"	CENTER OF GRAVITY IN MM		
		LB	KG		X	Y	Z
704DNK24000AA	208/230-1-60	272	123.3	40-1/8 (1019)	20-1/2 (520.7)	15-3/4 (400.1)	16-1/2 (419.1)
704D(N/P)XA36000AA	208/230-1, 208/230-3-60	277	125.5	42-1/8 (1070)	20-1/2 (520.7)	15-3/4 (400.1)	16-13/16 (421.0)
704D(N/P)YA36000AA	208/230-1, 208/230-3-60	283	128.3	46-1/8 (1172)	20-1/2 (520.7)	15-3/4 (400.1)	17 (431.8)
704DEXA36000AA	480-3-60	297	134.6	46-1/8 (1172)	20-1/2 (520.7)	15-3/4 (400.1)	17 (431.8)

UNITS	CORNER WEIGHT LB/KG			
	"1"	"2"	"3"	"4"
704DNK24000AA	208/230 54.4 (24.7)	43.5 (19.7)	65.2 (29.6)	108.7 (49.3)
704D(N/P)XA36000AA	208/230 55.4 (25.1)	44.3 (20.1)	66.4 (30.2)	110.7 (50.3)
704D(N/P)YA36000AA	208/230 56.6 (25.7)	45.2 (20.5)	67.9 (30.8)	113.1 (51.3)
704DEXA36000AA	480 56.6 (25.7)	45.2 (20.5)	76.9 (34.9)	118.1 (53.6)

NOTE: ALL TABLE DATA RELEVANT FOR ALL FACTORY INSTALLED OPTIONS EXCEPT ECONOMIZER

REQUIRED CLEARANCES TO COMBUSTIBLE MATL.

	INCHES (MM)
TOP OF UNIT.....	14 (355.6)
DUCT SIDE OF UNIT.....	2 (50.8)
SIDE OPPOSITE DUCTS.....	6 (152.4)
ELECTRICAL PANEL.....	36 (914.4)

REC. REQUIRED CLEARANCES

	INCHES (MM)
BETWEEN UNITS, POWER ENTRY SIDE.....	42 (1066.8)
UNIT AND UNGROUNDED SURFACES, POWER ENTRY SIDE.....	36 (914.4)
UNIT AND BLOCK OR CONCRETE WALLS AND OTHER GROUNDED SURFACES, POWER ENTRY SIDE.....	42 (1066.8)

REQUIRED CLEARANCE FOR OPERATION AND SERVICING

	INCHES (MM)
EVAP. COIL ACCESS SIDE.....	36 (914.4)
POWER ENTRY SIDE.....	42 (1066.8)
UNIT TOP (FOR REC. REQUIREMENTS).....	48 (1219.2)
UNIT TOP, POWER ENTRY SIDE.....	36 (914.4)
DUCT OPPOSITE DUCTS.....	12 (304.8)

*MINIMUM DISTANCES IF UNIT IS PLACED LESS THAN 12 (304.8) FROM WALL SYSTEM, THEN SYSTEM PERFORMANCE MAY BE COMPROMISED.

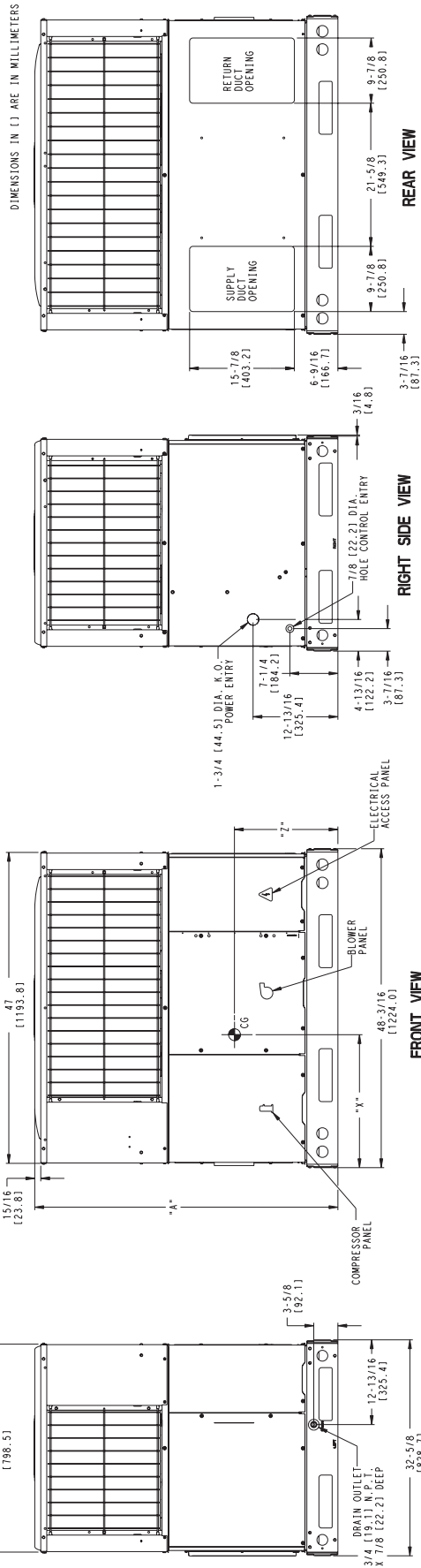

REV. 2.0
50ES500506

704D--A

UNIT DIMENSIONS - 704D--A42-60

704D--A

UNIT	ELECTRICAL CHARACTERISTICS	UNIT WT.		UNIT HEIGHT		CENTER OF GRAVITY IN/WM					
		LB.	KG.	"A"	"A"	X	Y	Z	7		
704D(N/P)XA42000AA	208/230-1, 208/230-3-60	389	167.5	44-3/4	1137	20-1/4	514.4	17-1/2	444.5	17-1/8	435.0
704DEXA42000AA	460-3-60	383	173.8	44-3/4	1137	20-1/4	514.4	17-1/2	444.5	17-1/8	435.0
704D(N/P)XA48000AA	208/230-1, 208/230-3-60	375	170.2	46-3/4	1187	20-1/4	514.4	17-1/2	444.5	17-3/8	441.3
704DEXA48000AA	460-3-60	389	176.6	46-3/4	1187	20-1/4	514.4	17-1/2	444.5	17-3/8	441.3
704D(N/P)XA60000AA	208/230-1, 208/230-3-60	397	180.2	46-3/4	1187	20-1/4	514.4	17-1/2	444.5	17-5/8	447.7
704DEXA60000AA	460-3-60	411	186.5	46-3/4	1187	20-1/4	514.4	17-1/2	444.5	17-5/8	447.7

UNITS	CORNER WEIGHT LBS/KG			
	"1"	"2"	"3"	"4"
704D(N/P)XA42000AA	208/230 73.8	33.5	59.1	26.8
704DEXA42000AA	460 73.8	33.5	59.1	26.8
704D(N/P)XA48000AA	208/230 75.0	34.1	60.0	27.3
704DEXA48000AA	460 75.0	34.1	60.0	27.3
704D(N/P)XA60000AA	208/230 79.4	36.1	63.6	28.9
704DEXA60000AA	460 79.4	36.1	63.6	28.9

NOTE: ALL TABLE DATA RELEVANT FOR ALL FACTORY INSTALLED OPTIONS EXCEPT ECONOMIZER

REQUIRED CLEARANCES TO COMBUSTIBLE MTL

	INCHES (MM)
TOP OF UNIT	12 (305.6)
DUCT SIDE OF UNIT	2 (50.8)
SIDE OPPOSITE DUCTS	14 (355.6)
BOTTOM OF UNIT	0 (0.0)
ELECTRICAL PANEL	36 (914.4)

NEC REQUIRED CLEARANCES

	INCHES (MM)
BETWEEN UNITS, POWER ENTRY SIDE	42 (1066.8)
BETWEEN GROUNDED SURFACE, POWER ENTRY SIDE	42 (1066.8)
UNIT AND BLOCK OR CONCRETE WALLS AND OTHER GROUNDED SURFACES, POWER ENTRY SIDE	42 (1066.8)

REQUIRED CLEARANCE FOR OPERATION AND SERVICING

	INCHES (MM)
EVAP. COIL ACCESS SIDE	36 (914.0)
POWER ENTRY SIDE	42 (1066.8)
EXCEPT FOR NEC REQUIREMENTS	48 (1219.2)
DUCT SIDE OPPOSITE DUCTS	36 (914.0)
DUCT PANEL	12 (304.8)

*MINIMUM DISTANCES: IF UNIT IS PLACED LESS THAN 12 (304.8) FROM WALL SYSTEM, THEN SYSTEM PERFORMANCE MAY BE COMPROMISED.

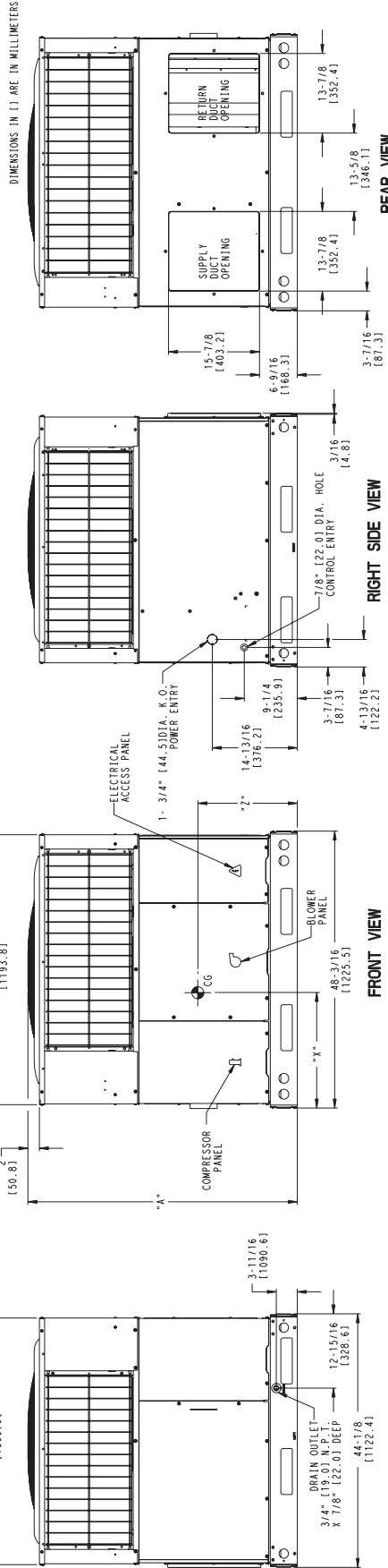

50ES500507
REV 2.0

ACCESSORY ROOF CURB - 704D--A24-60

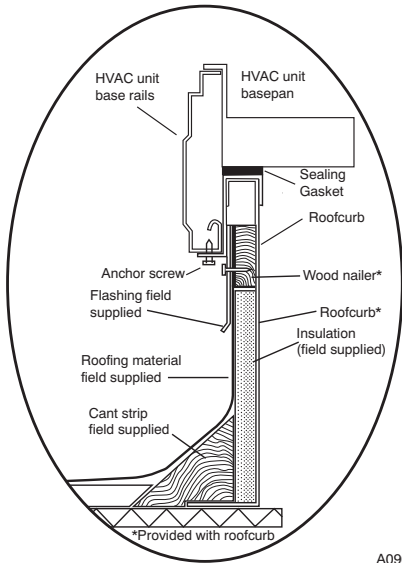

ROOF CURB DETAIL

A09090

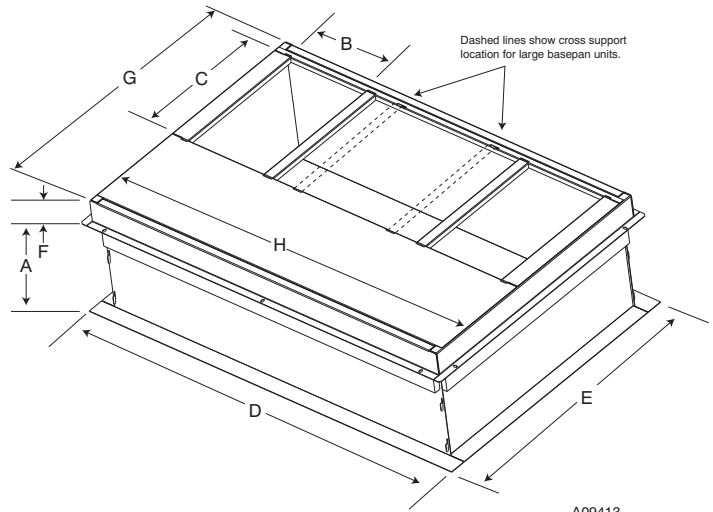

SMALL/COMMON CURB

A09413

704D--A

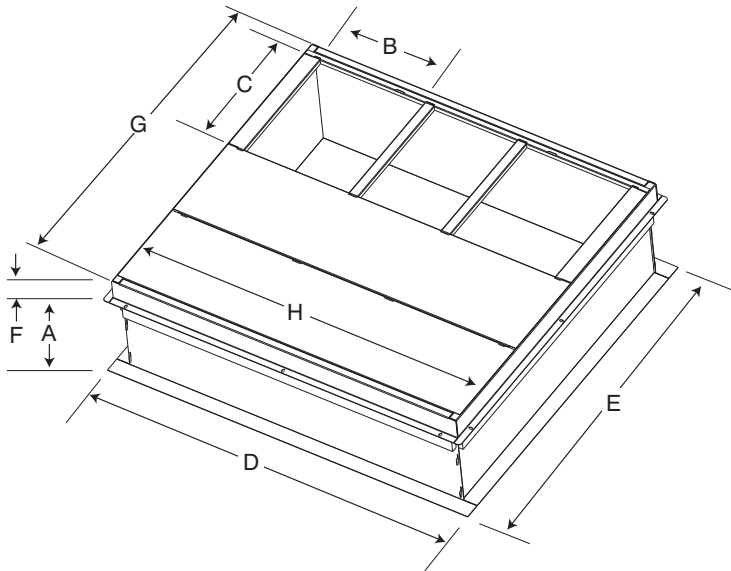

LARGE CURB

A09415

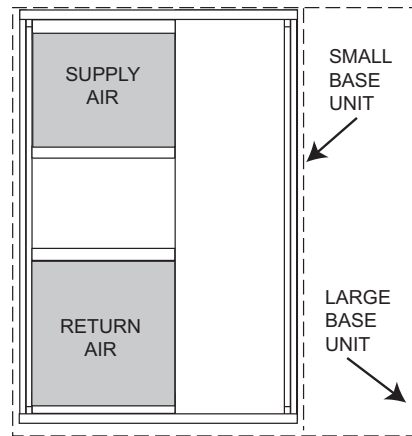

UNIT PLACEMENT ON COMMON CURB

A09094

SMALL OR LARGE BASE UNIT

A09414

UNIT SIZE	CATALOG NUMBER	A IN. (mm)	B (small/common base) IN. (mm)*	B (large base) IN. (mm)*	C IN. (mm)	D IN. (mm)	E IN. (mm)	F IN. (mm)	G IN. (mm)	H IN. (mm)	
Small or Large	CPRFCURB010A00	11 (279)	10 (254)	14 (356)	16 (406)	47.8 (1214)	32.4 (822)	2.7 (69)	30.6 (778)	46.1 (1170)	
	CPRFCURB011A00	14 (356)									42.2 (1072)
Large	CPRFCURB012A00	11 (279)	14 (356)				43.9 (1116)		42.2 (1072)		46.1 (1170)
	CPRFCURB013A00	14 (356)									

* Part Numbers CPRFCURB010A00 and CPRFCURB011A00 can be used on both small and large basepan units. The cross supports must be located based on whether the unit is a small basepan or a large basepan.

NOTES:

1. Roof curb must be set up for unit being installed.
2. Seal strip must be applied, as required, to unit being installed.
3. Roof curb is made of 16-gauge steel.
4. Attach ductwork to curb (flanges of duct rest on curb).
5. Insulated panels: 1-in. (25.4 mm) thick fiberglass 1 lb. density.

SELECTION PROCEDURE (WITH EXAMPLE)

1. Determine cooling and heating requirements at design conditions:

Given:

- Required Cooling Capacity (TC) 34,000 Btuh
- Sensible Heat Capacity (SHC) 25,000 Btuh
- Required Heating Capacity 30,000 Btuh
- Condenser Entering Air Temperature 95°F(35°C)
- Indoor-Air Temperature 80°F (26°C) edb
67°F (19°C) ewb
- Evaporator Air Quantity 1200 CFM
- External Static Pressure 0.30 IN. W.C.
- Electrical Characteristics 230-1-60

2. Select unit based on required cooling capacity.

Enter Net Cooling Capacities table at condenser entering temperature of 95°F (35°C), indoor air entering at 1200 CFM and 67°F (19°C) ewb (entering wet bulb). The unit will provide a total capacity of 34,400 Btuh and a SHC of 25,900 Btuh.

3. Select electric heat.

The required heating capacity is 30,000 Btuh.

Determine additional electric heat capacity in kW.

$$\frac{30,000 \text{ Btuh}}{3,414 \text{ Btuh/kW}} = 8.8 \text{ kW of heat required}$$

Enter the electric Heater Packages table for 208/240, single-phase, 704D--A36 unit. The 10 kW heater at 240v most closely satisfies the heating required. To calculate kW at the 230v, multiply the heater kW by multiplication factor 0.92 found in the Wattage Multiplication Factors table.

$$10 \text{ kW} \times 0.92 = 9.2 \text{ kW}$$

$$9.2 \text{ kW} \times 3414 = 31,409 \text{ Btuh}$$

4. Determine fan speed and power requirements at design conditions.

Before entering the air delivery tables, calculate the total static pressure required. From the given example, the Wet Coil Pressure Drop Table, and the Filter Pressure Drop Table:

External Static Pressure	0.30 IN. W.C.
Filter	0.14 IN. W.C.
Wet Coil Pressure Drop	<u>0.10 IN. W.C.</u>
Total Static Pressure	0.54 IN. W.C.

Enter the table for Wet Coil Air Delivery—horizontal discharge, 230. At 0.60 IN. W.C. ESP (external static pressure) and medium-high speed, the fan will deliver 1316 cfm.

5. Select unit that corresponds to power source available.

The Electrical Data Table shows that the unit is designed to operate at 208/230-1-60.

PERFORMANCE DATA

704D--A24

EVAPORATOR AIR CFM/BF	EWB °F (°C)	CONDENSER ENTERING AIR TEMPERATURES °F (°C)												Total Sys KW					
		75 (23.9)			85 (29.4)			95 (35)			105 (40.6)			115 (46.1)			125 (51.7)		
		Capacity MBtuh	Sens	Total Sys kW	Capacity MBtuh	Sens	Total Sys kW	Capacity MBtuh	Sens	Total Sys kW	Capacity MBtuh	Sens	Total Sys kW	Capacity MBtuh	Sens	Total Sys kW	Capacity MBtuh	Sens	Total Sys kW
700/0.07	57 (13.8)	22.74	22.74	1.66	21.26	21.26	1.85	19.77	19.77	2.06	18.28	18.28	2.29	16.77	16.77	2.54	15.24	15.24	2.80
	62 (16.6)	23.94	20.55	1.66	19.57	19.57	1.86	20.42	18.59	2.07	17.59	17.59	2.30	16.93	16.93	2.54	15.24	15.24	2.80
	63* (17.2)	24.48	17.00	1.67	16.12	16.12	1.86	20.88	15.23	2.07	14.35	14.35	2.30	17.27	13.46	2.54	15.45	12.56	2.81
	67 (19.4)	26.34	17.55	1.67	16.65	16.65	1.86	22.49	15.76	2.07	14.86	14.86	2.30	18.64	13.97	2.55	16.70	13.07	2.82
	72 (22.2)	28.95	14.51	1.67	13.70	13.70	1.87	24.76	12.88	2.08	12.07	12.07	2.31	20.56	11.25	2.56	18.45	10.43	2.83
	57 (13.8)	23.78	23.78	1.68	22.21	22.21	1.87	20.64	20.64	2.08	19.06	19.06	2.31	17.46	17.46	2.56	15.85	15.85	2.82
800/0.09	62 (16.6)	24.57	22.03	1.68	20.99	20.99	1.87	20.94	19.93	2.08	18.83	18.83	2.31	17.46	17.46	2.56	15.85	15.85	2.82
	63* (17.2)	25.10	18.06	1.68	17.14	17.14	1.88	21.36	16.21	2.09	15.29	15.29	2.32	17.62	14.37	2.56	15.74	13.44	2.82
	67 (19.4)	27.00	18.66	1.69	17.73	17.73	1.88	23.00	16.80	2.09	15.87	15.87	2.32	19.01	14.94	2.57	17.00	14.00	2.83
	72 (22.2)	29.85	15.23	1.69	14.39	14.39	1.89	25.30	13.54	2.10	12.71	12.71	2.33	20.96	11.86	2.58	18.77	11.01	2.84
	57 (13.8)	24.67	24.67	1.70	23.02	23.02	1.89	21.37	21.37	2.10	19.71	19.71	2.33	18.05	18.05	2.58	16.36	16.36	2.84
	62 (16.6)	25.09	23.40	1.70	22.27	22.27	1.89	21.39	21.39	2.10	19.71	19.71	2.33	18.04	18.04	2.58	16.35	16.35	2.84
900/0.1	63* (17.2)	25.60	19.06	1.70	18.11	18.11	1.89	21.74	17.15	2.10	16.20	16.20	2.33	17.89	15.24	2.58	15.96	14.27	2.84
	67 (19.4)	27.52	19.73	1.70	18.76	18.76	1.90	23.40	17.80	2.11	16.83	16.83	2.34	19.29	15.87	2.59	17.23	14.89	2.85
	72 (22.2)	30.21	15.91	1.71	15.04	15.04	1.90	25.72	14.18	2.11	13.31	13.31	2.35	21.26	12.45	2.60	19.02	11.58	2.86

See Legend and Notes on Page 18.

PERFORMANCE DATA
704D--A30

EVAPORATOR AIR		CONDENSER ENTERING AIR TEMPERATURES °F (°C)																	
		75 (23.9)			85 (29.4)			95 (35)			105 (40.6)			115 (46.1)			125 (51.7)		
		Capacity MBtuh	Sens	Total Sys KW	Capacity MBtuh	Sens	Total Sys KW	Capacity MBtuh	Sens	Total Sys KW	Capacity MBtuh	Sens	Total Sys KW	Capacity MBtuh	Sens	Total Sys KW			
875/0.03	EWB °F (°C)	29.20	29.20	2.09	27.20	27.20	2.30	25.19	25.19	2.52	23.18	23.18	2.77	21.16	21.16	3.04	19.13	19.13	3.32
		30.09	26.44	2.09	27.78	25.28	2.30	25.48	24.10	2.52	23.22	23.12	2.77	21.16	21.16	3.04	19.12	19.12	3.32
		30.75	21.65	2.09	28.36	20.61	2.30	25.99	19.56	2.52	23.63	18.51	2.77	21.26	17.45	3.04	18.90	16.38	3.32
		33.12	22.39	2.08	30.58	21.34	2.29	28.05	20.29	2.52	25.52	19.23	2.77	23.00	18.16	3.04	20.48	17.08	3.32
		36.50	18.28	2.08	33.73	17.33	2.29	30.97	16.37	2.52	28.22	15.41	2.77	25.48	14.44	3.04	22.73	13.46	3.32
		30.51	30.51	2.12	28.39	28.39	2.33	26.27	26.27	2.56	24.14	24.14	2.80	22.01	22.01	3.07	19.87	19.87	3.35
		30.85	28.45	2.12	28.49	28.24	2.33	26.26	26.26	2.56	24.14	24.14	2.80	22.01	22.01	3.07	19.86	19.86	3.35
1000/0.03	EWB °F (°C)	31.44	23.11	2.12	28.97	22.02	2.33	26.51	20.93	2.56	24.07	19.84	2.81	21.63	18.73	3.07	19.21	17.80	3.35
		33.86	23.94	2.12	31.22	22.85	2.33	28.60	21.75	2.55	25.99	20.65	2.80	23.40	19.53	3.07	20.80	18.40	3.35
		37.30	19.27	2.11	34.43	18.29	2.32	31.58	17.30	2.55	28.74	16.31	2.80	25.91	15.31	3.07	23.07	14.29	3.35
		31.61	31.61	2.15	29.39	29.39	2.36	27.17	27.17	2.59	24.95	24.95	2.84	22.72	22.72	3.10	20.48	20.48	3.39
		31.61	31.61	2.15	29.39	29.39	2.36	27.17	27.17	2.59	24.95	24.95	2.84	22.72	22.72	3.10	20.48	20.48	3.39
		31.97	24.51	2.15	29.43	23.38	2.36	26.91	22.25	2.59	24.41	21.10	2.84	21.92	19.95	3.10	19.45	18.75	3.39
		34.42	25.44	2.15	31.71	24.30	2.36	29.02	23.16	2.59	26.35	22.01	2.84	23.69	20.84	3.10	21.05	19.65	3.39
1125/0.04	EWB °F (°C)	37.91	20.22	2.14	34.96	19.20	2.35	32.03	18.19	2.58	29.12	17.17	2.83	26.22	16.14	3.10	23.32	15.10	3.39

See Legend and Notes on Page 18.

PERFORMANCE DATA (CONT)

704D--A36

EVAPORATOR AIR		CONDENSER ENTERING AIR TEMPERATURES °F (°C)																	
		75 (23.9)			85 (29.4)			95 (35)			105 (40.6)			115 (46.1)			125 (51.7)		
		Capacity MBtuh	Sens	Total Sys KW	Capacity MBtuh	Sens	Total Sys KW	Capacity MBtuh	Sens	Total Sys KW	Capacity MBtuh	Sens	Total Sys KW	Capacity MBtuh	Sens	Total Sys KW	Capacity MBtuh	Sens	Total Sys KW
CFM/BF	EWB °F (°C)																		
1050/0.04	57 (13.8)	35.66	32.84	2.38	30.06	27.32	3.07	30.06	27.32	3.07	30.06	27.32	3.07	30.06	27.32	3.07	30.06	27.32	3.07
	62 (16.6)	37.06	33.82	2.39	30.65	27.56	3.07	30.65	27.56	3.07	30.65	27.56	3.07	30.65	27.56	3.07	30.65	27.56	3.07
	63* (17.2)	37.87	34.55	2.39	31.28	28.09	3.08	31.28	28.09	3.08	31.28	28.09	3.08	31.28	28.09	3.08	31.28	28.09	3.08
	67 (19.4)	40.79	37.23	2.39	33.74	30.32	3.08	33.74	30.32	3.08	33.74	30.32	3.08	33.74	30.32	3.08	33.74	30.32	3.08
	72 (22.2)	44.91	41.02	2.39	37.19	33.45	3.09	37.19	33.45	3.09	37.19	33.45	3.09	37.19	33.45	3.09	37.19	33.45	3.09
	57 (13.8)	37.24	34.27	2.43	31.33	28.44	3.12	31.33	28.44	3.12	31.33	28.44	3.12	31.33	28.44	3.12	31.33	28.44	3.12
	62 (16.6)	37.97	34.64	2.43	31.35	28.43	3.12	31.35	28.43	3.12	31.35	28.43	3.12	31.35	28.43	3.12	31.35	28.43	3.12
1200/0.04	63* (17.2)	38.73	35.29	2.43	31.91	28.60	3.12	31.91	28.60	3.12	31.91	28.60	3.12	31.91	28.60	3.12	31.91	28.60	3.12
	67 (19.4)	41.71	38.02	2.44	34.40	30.86	3.13	34.40	30.86	3.13	34.40	30.86	3.13	34.40	30.86	3.13	34.40	30.86	3.13
	72 (22.2)	45.90	41.86	2.44	37.91	34.05	3.13	37.91	34.05	3.13	37.91	34.05	3.13	37.91	34.05	3.13	37.91	34.05	3.13
	57 (13.8)	38.59	35.47	2.48	32.40	29.37	3.17	32.40	29.37	3.17	32.40	29.37	3.17	32.40	29.37	3.17	32.40	29.37	3.17
	62 (16.6)	38.77	35.46	2.48	32.39	29.37	3.17	32.39	29.37	3.17	32.39	29.37	3.17	32.39	29.37	3.17	32.39	29.37	3.17
	63* (17.2)	39.40	35.85	2.48	32.38	28.99	3.17	32.38	28.99	3.17	32.38	28.99	3.17	32.38	28.99	3.17	32.38	28.99	3.17
	67 (19.4)	42.41	38.61	2.48	34.89	31.27	3.18	34.89	31.27	3.18	34.89	31.27	3.18	34.89	31.27	3.18	34.89	31.27	3.18
1350/0.05	72 (22.2)	46.65	42.51	2.49	38.45	34.49	3.18	38.45	34.49	3.18	38.45	34.49	3.18	38.45	34.49	3.18	38.45	34.49	3.18
	57 (13.8)	35.66	32.84	2.38	30.06	27.32	3.07	30.06	27.32	3.07	30.06	27.32	3.07	30.06	27.32	3.07	30.06	27.32	3.07
	62 (16.6)	37.06	33.82	2.39	30.65	27.56	3.07	30.65	27.56	3.07	30.65	27.56	3.07	30.65	27.56	3.07	30.65	27.56	3.07
	63* (17.2)	37.87	34.55	2.39	31.28	28.09	3.08	31.28	28.09	3.08	31.28	28.09	3.08	31.28	28.09	3.08	31.28	28.09	3.08
	67 (19.4)	40.79	37.23	2.39	33.74	30.32	3.08	33.74	30.32	3.08	33.74	30.32	3.08	33.74	30.32	3.08	33.74	30.32	3.08
	72 (22.2)	44.91	41.02	2.39	37.19	33.45	3.09	37.19	33.45	3.09	37.19	33.45	3.09	37.19	33.45	3.09	37.19	33.45	3.09
	57 (13.8)	37.24	34.27	2.43	31.33	28.44	3.12	31.33	28.44	3.12	31.33	28.44	3.12	31.33	28.44	3.12	31.33	28.44	3.12
See Legend and Notes on Page 18.	62 (16.6)	37.97	34.64	2.43	31.35	28.43	3.12	31.35	28.43	3.12	31.35	28.43	3.12	31.35	28.43	3.12	31.35	28.43	3.12
	63* (17.2)	38.73	35.29	2.43	31.91	28.60	3.12	31.91	28.60	3.12	31.91	28.60	3.12	31.91	28.60	3.12	31.91	28.60	3.12
	67 (19.4)	41.71	38.02	2.44	34.40	30.86	3.13	34.40	30.86	3.13	34.40	30.86	3.13	34.40	30.86	3.13	34.40	30.86	3.13
	72 (22.2)	45.90	41.86	2.44	37.91	34.05	3.13	37.91	34.05	3.13	37.91	34.05	3.13	37.91	34.05	3.13	37.91	34.05	3.13
	57 (13.8)	38.59	35.47	2.48	32.40	29.37	3.17	32.40	29.37	3.17	32.40	29.37	3.17	32.40	29.37	3.17	32.40	29.37	3.17
	62 (16.6)	38.77	35.46	2.48	32.39	29.37	3.17	32.39	29.37	3.17	32.39	29.37	3.17	32.39	29.37	3.17	32.39	29.37	3.17
	63* (17.2)	39.40	35.85	2.48	32.38	28.99	3.17	32.38	28.99	3.17	32.38	28.99	3.17	32.38	28.99	3.17	32.38	28.99	3.17
67 (19.4)	42.41	38.61	2.48	34.89	31.27	3.18	34.89	31.27	3.18	34.89	31.27	3.18	34.89	31.27	3.18	34.89	31.27	3.18	
72 (22.2)	46.65	42.51	2.49	38.45	34.49	3.18	38.45	34.49	3.18	38.45	34.49	3.18	38.45	34.49	3.18	38.45	34.49	3.18	

See Legend and Notes on Page 18.

PERFORMANCE DATA (CONT)

704D--A42

EVAPORATOR AIR		CONDENSER ENTERING AIR TEMPERATURES °F (°C)																		
		75 (23.9)			85 (29.4)			95 (35)			105 (40.6)			115 (46.1)			125 (51.7)			
		Capacity MBtuh	Total Sys KW	Sens	Capacity MBtuh	Total Sys KW	Sens	Capacity MBtuh	Total Sys KW	Sens	Capacity MBtuh	Total Sys KW	Sens	Capacity MBtuh	Total Sys KW	Sens	Capacity MBtuh	Total Sys KW	Sens	
EWB °F (°C)	CFM/BF	57 (13.8)	40.45	40.45	3.00	37.98	37.98	3.37	35.49	35.49	3.78	32.98	32.98	4.20	30.44	30.44	4.65	27.84	27.84	5.10
		62 (16.6)	42.06	37.63	2.94	35.73	35.73	3.33	36.25	33.83	3.74	33.37	31.92	4.18	30.48	30.39	4.64	27.88	27.88	5.10
1225/0.03		63* (17.2)	42.83	30.96	2.91	29.27	29.27	3.31	36.96	27.59	3.72	33.97	25.92	4.17	30.95	24.26	4.63	27.90	22.59	5.10
		67 (19.4)	46.12	31.94	2.80	30.23	30.23	3.19	39.72	28.52	3.61	36.53	26.83	4.05	33.31	25.15	4.52	30.04	23.46	4.99
1400/0.04		72 (22.2)	50.58	26.16	2.65	24.61	24.61	3.04	43.59	23.08	3.46	40.11	21.56	3.90	36.60	20.05	4.37	33.04	18.53	4.84
		57 (13.8)	42.24	42.24	2.98	39.61	39.61	3.35	36.97	36.97	3.76	34.32	34.32	4.18	31.63	31.63	4.63	28.88	28.88	5.08
1575/0.05		62 (16.6)	43.11	40.44	2.95	38.38	38.38	3.34	37.15	36.28	3.75	34.31	34.31	4.18	31.62	31.62	4.63	28.88	28.88	5.08
		63* (17.2)	43.91	32.97	2.92	31.21	31.21	3.32	37.71	29.45	3.73	34.61	27.70	4.18	31.49	25.96	4.64	28.35	24.21	5.12
1575/0.05		67 (19.4)	47.15	34.07	2.81	32.28	32.28	3.20	40.50	30.50	3.62	37.19	28.73	4.06	33.86	26.97	4.53	30.50	25.20	5.00
		72 (22.2)	51.67	27.51	2.65	25.91	25.91	3.05	44.42	24.32	3.46	40.81	22.75	3.91	37.19	21.19	4.38	33.51	19.62	4.85
1575/0.05		57 (13.8)	43.75	43.75	2.97	40.99	40.99	3.34	38.22	38.22	3.75	35.43	35.43	4.17	32.62	32.62	4.62	29.74	29.74	5.07
		62 (16.6)	44.02	42.95	2.96	41.01	41.01	3.34	38.21	38.21	3.75	35.43	35.43	4.17	32.61	32.61	4.62	29.74	29.74	5.07
1575/0.05		63* (17.2)	44.67	34.90	2.94	33.06	33.06	3.33	38.28	31.23	3.75	35.10	29.41	4.20	31.91	27.58	4.66	28.70	25.74	5.14
		67 (19.4)	47.93	36.13	2.82	34.26	34.26	3.21	41.09	32.40	3.63	37.69	30.56	4.08	34.28	28.71	4.54	30.85	26.85	5.02
1575/0.05		72 (22.2)	52.51	28.80	2.67	27.15	27.15	3.06	45.05	25.51	3.48	41.34	23.89	3.93	37.63	22.28	4.39	33.86	20.67	4.87

See Legend and Notes on Page 18.

PERFORMANCE DATA (CONT)

704D--A48

EVAPORATOR AIR		CONDENSER ENTERING AIR TEMPERATURES °F (°C)																	
		75 (23.9)			85 (29.4)			95 (35)			105 (40.6)			115 (46.1)			125 (51.7)		
		CFMBF	EWB °F (°C)	Capacity MBtuh	Total Sys KW	Capacity MBtuh	Total Sys KW	Capacity MBtuh	Total Sys KW	Capacity MBtuh	Total Sys KW	Capacity MBtuh	Total Sys KW	Capacity MBtuh	Total Sys KW	Capacity MBtuh	Total Sys KW		
	57 (13.8)	46.51	3.29	43.60	3.68	40.66	4.11	37.70	4.56	34.70	5.05	31.64	5.55	28.60	5.05	25.50	5.55		
	62 (16.6)	48.43	3.29	40.09	3.68	38.24	4.10	36.35	4.56	34.81	5.05	31.64	5.55	28.60	5.05	25.50	5.55		
1400/0.04	63* (17.2)	49.45	3.29	45.95	3.68	42.43	4.10	38.89	4.56	35.34	5.05	31.75	5.55	28.60	5.05	25.50	5.55		
	67 (19.4)	53.14	3.29	49.39	3.68	45.62	4.10	41.85	4.55	38.05	5.04	34.20	5.55	31.10	5.13	27.98	5.64		
	72 (22.2)	58.33	3.28	54.23	3.67	50.11	4.09	46.00	4.55	41.85	5.03	37.64	5.54	34.10	5.13	30.98	5.64		
	57 (13.8)	48.55	3.35	45.46	3.74	42.35	4.16	39.21	4.61	36.04	5.10	32.81	5.60	29.70	5.10	26.60	5.60		
	62 (16.6)	49.82	3.35	46.10	3.74	42.60	4.16	39.21	4.61	36.04	5.10	32.80	5.60	29.70	5.10	26.60	5.60		
1600/0.05	63* (17.2)	50.57	3.35	46.92	3.74	43.27	4.16	39.61	4.61	35.94	5.10	32.24	5.60	29.20	5.10	26.20	5.60		
	67 (19.4)	54.31	3.34	50.41	3.73	46.50	4.15	42.59	4.61	38.66	5.09	34.70	5.60	31.70	5.09	28.20	5.60		
	72 (22.2)	59.58	3.34	55.92	3.73	51.05	4.15	46.80	4.60	42.51	5.08	38.17	5.59	34.70	5.08	30.20	5.59		
	57 (13.8)	50.26	3.40	47.02	3.79	43.76	4.21	40.47	4.66	37.15	5.15	33.76	5.65	30.20	5.15	27.20	5.65		
	62 (16.6)	50.84	3.40	47.06	3.79	43.75	4.21	40.46	4.66	37.14	5.15	33.76	5.65	30.20	5.15	27.20	5.65		
1800/0.06	63* (17.2)	51.44	3.40	47.67	3.79	43.92	4.21	40.16	4.67	36.40	5.15	32.82	5.66	29.70	5.15	26.80	5.66		
	67 (19.4)	55.22	3.40	51.19	3.79	47.17	4.21	43.16	4.66	39.13	5.14	35.08	5.65	31.10	5.14	28.10	5.65		
	72 (22.2)	60.54	3.40	56.16	3.78	51.77	4.20	47.40	4.65	43.00	5.13	38.55	5.64	33.98	5.13	30.98	5.64		

See Legend and Notes on Page 18.

PERFORMANCE DATA (CONT)

704D--A60

EVAPORATOR AIR		CONDENSER ENTERING AIR TEMPERATURES °F (°C)												Total Sys KW		Total Sys KW							
		75 (23.9)			85 (29.4)			95 (35)			105 (40.6)							115 (46.1)			125 (51.7)		
		Capacity MBtuh	Sens	Total Sys KW	Capacity MBtuh	Sens	Total Sys KW	Capacity MBtuh	Sens	Total Sys KW	Capacity MBtuh	Sens	Total Sys KW					Capacity MBtuh	Sens	Total Sys KW	Capacity MBtuh	Sens	Total Sys KW
CFM/BF	EWB °F (°C)	Total Capacity MBtuh	Total Sys KW	Total Capacity MBtuh	Total Sys KW	Total Capacity MBtuh	Total Sys KW	Total Capacity MBtuh	Total Sys KW	Total Capacity MBtuh	Total Sys KW	Total Capacity MBtuh	Total Sys KW	Total Capacity MBtuh	Total Sys KW	Total Capacity MBtuh	Total Sys KW	Total Capacity MBtuh	Total Sys KW				
1750/0.02	57 (13.8)	57.89	57.89	4.22	54.53	54.53	4.64	51.13	51.13	5.08	47.68	47.68	5.56	44.15	44.15	6.06	40.50	40.50	6.59				
	62 (16.6)	59.66	51.98	4.24	49.84	49.84	4.65	51.77	47.68	5.09	47.84	45.44	5.56	44.15	44.15	6.06	40.49	40.49	6.59				
	63*	60.79	42.58	4.25	40.64	40.64	4.66	52.64	38.69	5.10	48.53	36.74	5.57	44.37	34.78	6.06	40.12	32.78	6.58				
	67 (19.4)	65.28	43.94	4.28	60.89	41.97	4.70	56.50	40.00	5.14	52.08	38.03	5.61	47.59	36.03	6.10	43.00	34.00	6.62				
	72 (22.2)	71.52	35.78	4.34	66.71	33.95	4.75	61.88	32.13	5.19	57.02	30.30	5.66	52.07	28.45	6.15	47.01	26.57	6.66				
	57 (13.8)	60.39	60.39	4.33	56.80	56.80	4.74	53.18	53.18	5.18	49.50	49.50	5.66	45.74	45.74	6.16	41.85	41.85	6.68				
	62 (16.6)	61.11	55.94	4.33	53.59	53.59	4.74	53.18	53.18	5.18	49.50	49.50	5.66	45.74	45.74	6.16	41.85	41.85	6.68				
2000/0.02	63*	62.07	45.41	4.34	57.83	43.39	4.75	53.59	41.36	5.19	49.33	39.33	5.66	45.03	37.28	6.15	40.84	35.18	6.67				
	67 (19.4)	66.80	46.95	4.38	62.04	44.89	4.79	57.48	42.84	5.23	52.89	40.78	5.69	48.25	38.70	6.19	43.52	36.58	6.70				
	72 (22.2)	72.81	37.66	4.43	67.90	35.78	4.85	62.90	33.90	5.28	57.85	32.01	5.75	52.74	30.11	6.24	47.52	28.18	6.74				
	57 (13.8)	62.47	62.47	4.43	58.69	58.69	4.84	54.87	54.87	5.28	51.00	51.00	5.75	47.03	47.03	6.25	42.94	42.94	6.77				
	62 (16.6)	62.48	62.48	4.43	58.68	58.68	4.84	54.86	54.86	5.28	50.99	50.99	5.75	47.03	47.03	6.25	42.94	42.94	6.77				
	63*	63.04	48.14	4.43	58.67	46.04	4.84	54.31	43.93	5.28	49.93	41.81	5.74	45.52	39.67	6.23	41.04	37.45	6.75				
	67 (19.4)	67.80	49.85	4.47	62.90	47.72	4.88	58.21	45.59	5.32	53.50	43.44	5.78	48.74	41.27	6.27	43.81	39.04	6.78				
2250/0.03	72 (22.2)	73.95	39.47	4.53	68.79	37.54	4.94	63.63	35.61	5.37	58.45	33.68	5.84	53.20	31.73	6.32	47.86	29.75	6.82				

See Legend and Notes on Page 18.

PERFORMANCE DATA (CONT)

* At 75°F (24°C) entering dry bulb – Tennessee Valley Authority (TVA) rating conditions; all others at 80°F (27°C) dry bulb.

LEGEND

BF—Bypass Factor
 edb—Entering Dry—Bulb
 Ewb—Entering Wet—Bulb
 kW—Total Unit Power Input
 SHC—Sensible Heat Capacity (1000 Btuh)
 TC—Total Capacity (1000 Btuh) (net)
 rh—Relative Humidity

COOLING NOTES:

1. Ratings are net; they account for the effects of the evaporator—fan motor power and heat.
2. Direct interpolation is permissible. Do not extrapolate.
3. The following formulas may be used:

$$t_{ldb} = t_{edb} - \frac{\text{Sensible capacity (Btuh)}}{1.10 \times \text{cfm}}$$

$$t_{lwb} = \frac{\text{Wet-bulb temperature corresponding to enthalpy}}{\text{air leaving evaporator coil } (h_{lwb})} \quad h_{lwb} = h_{ewb} - \frac{\text{total capacity (Btuh)}}{4.5 \times \text{cfm}}$$

Where: h_{ewb} = Enthalpy of air entering evaporator coil

4. The SHC is based on 80°F (26.6°C) edb temperature of air entering evaporator coil. Below 80°F (26.6°C) edb, subtract (corr factor x cfm) from SHC. Above 80°F (26.6°C) edb, add (corr factor x cfm) to SHC.

Correction Factor = $1.10 \times (1 + BF) \times (edb - 80)$.

5. Integrated capacity is maximum (instantaneous) capacity less the effect of frost on the outdoor coil and the heat required to defrost it.

PERFORMANCE DATA (CONT)

Multiplication Factors

HEATER VOLT RATING	VOLTAGE DISTRIBUTION V/3/60	MULTIPLICATION FACTOR
240	200 208 230 240 460	0.69 0.75 0.92 1.00 0.92

Dry Coil Air Delivery* - Horizontal Discharge - Unit 704D--A24-60

UNIT	MOTOR SPEED	WIRE COLOR	EXTERNAL STATIC PRESSURE (IN. W.C.)												
			0.1	0.2	0.3	0.4	0.5	0.6	0.7	0.8	0.9				
704D--A24	Low	Blue	754	650	538	429	---	---	---	---	---	---	---	---	---
	Med-Low	Pink	851	777	675	591	475	---	---	---	---	---	---	---	---
	Medium ¹	Red	941	851	774	684	576	479	---	---	---	---	---	---	---
	Med-High	Orange	1009	917	840	759	667	577	447	---	---	---	---	---	---
	High	Black	1241	1167	1111	1036	969	881	818	731	640	---	---	---	---
704D--A30	Low	Blue	741	638	547	415	---	---	---	---	---	---	---	---	---
	Med-Low	Pink	973	887	823	733	665	538	451	---	---	---	---	---	---
	Medium ¹	Red	1088	1023	954	881	800	723	658	583	461	---	---	---	---
	Med-High ¹	Orange	1140	1064	996	915	840	758	687	614	540	468	---	---	---
	High	Black	1202	1140	1082	1015	961	881	810	732	661	587	---	---	---
704D--A36	Low	Blue	1234	1168	1093	1021	961	894	825	759	687	---	---	---	---
	Med-Low	Pink	1290	1223	1154	1090	1027	977	918	851	782	---	---	---	---
	Medium ¹	Red	1354	1290	1226	1158	1102	1046	981	918	843	---	---	---	---
	Med-High	Orange	1606	1546	1489	1430	1371	1316	1258	1208	1140	---	---	---	---
	High	Black	1630	1580	1517	1463	1407	1339	1277	1210	1131	---	---	---	---
704D--A42	Low	Blue	1295	1234	1182	1126	1075	1016	955	898	857	---	---	---	---
	Med-Low	Pink	1345	1282	1235	1194	1140	1095	1027	974	921	---	---	---	---
	Medium ¹	Red	1505	1452	1413	1358	1323	1282	1234	1169	1130	---	---	---	---
	Med-High ¹	Orange	1545	1492	1449	1411	1362	1313	1278	1231	1188	---	---	---	---
	High	Black	1705	1643	1607	1568	1518	1483	1448	1404	1360	---	---	---	---
704D--A48	Low	Blue	1402	1351	1311	1263	1224	1172	1136	1080	1041	---	---	---	---
	Med-Low	Pink	1457	1404	1367	1318	1284	1233	1197	1144	1104	---	---	---	---
	Medium ¹	Red	1736	1695	1642	1601	1553	1512	1465	1427	1381	---	---	---	---
	Med-High	Orange	2149	2111	2062	2026	1980	1945	1905	1864	1823	---	---	---	---
	High	Black	2344	2306	2259	2203	2141	2070	2002	1951	1902	---	---	---	---
704D--A60	Med-Low	Pink	1678	1635	1602	1558	1513	1474	1438	1404	1349	---	---	---	---
	Medium ¹	Red	1962	1915	1880	1843	1794	1753	1711	1675	1628	---	---	---	---
	Med-High	Orange	2131	2088	2065	2013	1982	1941	1888	1860	1815	---	---	---	---
	High	Black	2461	2409	2339	2286	2192	2140	2062	1968	1874	---	---	---	---

* Air delivery values are without air filter and are for dry coil (See table 704D--A Wet Coil Pressure Drop table).

¹ Factory--shipped cooling speed

Note: Deduct field--supplied air filter pressure drop and wet coil pressure drop to obtain external static pressure available for ducting.

Shaded areas indicate airflows that are not recommended for dehumidification control.

Note: Deduct 10% for 208 volt operation.

PERFORMANCE DATA (CONT)

Dry Coil Air Delivery* - Downflow Discharge

UNIT	MOTOR SPEED	WIRE COLOR	EXTERNAL STATIC PRESSURE (IN. W.C.)															
			0.10	0.20	0.30	0.40	0.50	0.60	0.70	0.80	0.90	1.0						
704D--A24	Low	CFM	809	664	554	447	--	--	--	--	--	--	--	--	--	--	--	
		WATTS	85	82	87	95	--	--	--	--	--	--	--	--	--	--	--	--
		BHP	0.09	0.09	0.09	0.10	--	--	--	--	--	--	--	--	--	--	--	--
	MedLow	CFM	875	787	693	612	498	392	--	--	--	--	--	--	--	--	--	--
		WATTS	101	111	115	125	131	142	--	--	--	--	--	--	--	--	--	--
		BHP	0.11	0.12	0.12	0.13	0.14	0.15	--	--	--	--	--	--	--	--	--	--
	Medium	CFM	939	860	748	663	591	472	399	--	--	--	--	--	--	--	--	--
		WATTS	119	124	134	138	147	155	164	--	--	--	--	--	--	--	--	--
		BHP	0.13	0.13	0.14	0.15	0.16	0.17	0.18	--	--	--	--	--	--	--	--	--
	MedHigh	CFM	1026	949	873	786	694	604	516	--	--	--	--	--	--	--	--	--
		WATTS	146	151	161	167	177	183	195	--	--	--	--	--	--	--	--	--
		BHP	0.16	0.16	0.17	0.18	0.19	0.20	0.21	--	--	--	--	--	--	--	--	--
High	CFM	1264	1202	1134	1070	1002	931	870	806	699	610	--	--	--	--	--	--	
	WATTS	250	261	274	279	290	296	308	319	328	332	--	--	--	--	--	--	
	BHP	0.27	0.28	0.29	0.30	0.31	0.32	0.33	0.34	0.35	0.36	--	--	--	--	--	--	
704D--A30	Low	CFM	756	669	548	457	--	--	--	--	--	--	--	--	--	--	--	
		WATTS	84	90	96	106	--	--	--	--	--	--	--	--	--	--	--	--
		BHP	0.09	0.10	0.10	0.11	--	--	--	--	--	--	--	--	--	--	--	--
	MedLow	CFM	1002	928	842	733	660	560	450	--	--	--	--	--	--	--	--	--
		WATTS	144	155	161	173	185	192	203	--	--	--	--	--	--	--	--	--
		BHP	0.15	0.17	0.17	0.19	0.20	0.21	0.22	--	--	--	--	--	--	--	--	--
	Medium	CFM	1110	1025	967	879	814	706	611	509	--	--	--	--	--	--	--	--
		WATTS	188	195	205	211	223	236	243	255	--	--	--	--	--	--	--	--
		BHP	0.20	0.21	0.22	0.23	0.24	0.25	0.26	0.27	--	--	--	--	--	--	--	--
	MedHigh ¹	CFM	1160	1091	1004	945	866	804	699	615	496	--	--	--	--	--	--	--
		WATTS	213	225	232	243	249	261	273	285	291	--	--	--	--	--	--	--
		BHP	0.23	0.24	0.25	0.26	0.27	0.28	0.29	0.31	0.31	--	--	--	--	--	--	--
High	CFM	1240	1173	1110	1031	966	902	821	726	626	--	--	--	--	--	--	--	
	WATTS	254	266	274	284	295	302	315	327	331	--	--	--	--	--	--	--	
	BHP	0.27	0.29	0.29	0.30	0.32	0.32	0.34	0.35	0.35	--	--	--	--	--	--	--	

704D--A

Dry Coil Air Delivery* - Downflow Discharge

UNIT	MOTOR SPEED	WIRE COLOR	EXTERNAL STATIC PRESSURE (IN. W.C.)										
			0.10	0.20	0.30	0.40	0.50	0.60	0.70	0.80	0.90	1.0	
704D--A36	Low	Blue	CFM	1277	1215	1147	1094	1045	992	932	874	826	757
			WATTS	285	289	299	305	314	319	328	335	347	352
			BHP	0.31	0.31	0.32	0.33	0.34	0.34	0.35	0.35	0.36	0.37
	MedLow	Pink	CFM	1312	1260	1203	1153	1095	1050	995	943	889	829
			WATTS	314	324	329	340	344	355	361	372	382	387
			BHP	0.34	0.35	0.35	0.36	0.37	0.38	0.39	0.40	0.41	0.42
	Medium ¹	Red	CFM	1381	1326	1269	1212	1161	1121	1070	1019	974	912
			WATTS	358	365	375	383	391	395	406	418	424	434
			BHP	0.38	0.39	0.40	0.41	0.42	0.42	0.44	0.45	0.45	0.47
	MedHigh	Orange	CFM	1631	1579	1525	1477	1423	1372	1336	1284	1233	1166
			WATTS	567	576	581	592	598	609	617	619	613	598
			BHP	0.61	0.62	0.62	0.63	0.64	0.65	0.66	0.66	0.66	0.64
High	Black	CFM	1681	1633	1575	1526	1478	1415	1366	1312	1249	1159	
		WATTS	618	626	636	644	652	653	649	642	627	602	
		BHP	0.66	0.67	0.68	0.69	0.70	0.70	0.70	0.70	0.69	0.67	0.65
704D--A42	Low	Blue	CFM	1365	1324	1284	1233	1181	1127	1084	1039	984	939
			WATTS	177	189	201	210	222	236	248	261	269	281
			BHP	0.19	0.20	0.22	0.23	0.24	0.25	0.27	0.28	0.29	0.30
	MedLow	Pink	CFM	1425	1384	1339	1301	1254	1199	1151	1104	1065	1015
			WATTS	197	210	223	235	248	257	271	284	296	305
			BHP	0.21	0.23	0.24	0.25	0.27	0.28	0.29	0.30	0.32	0.33
	Medium	Red	CFM	1582	1549	1509	1469	1433	1392	1346	1300	1249	1213
			WATTS	267	280	294	308	322	336	344	359	374	387
			BHP	0.29	0.30	0.32	0.33	0.35	0.36	0.37	0.38	0.40	0.42
	MedHigh ¹	Orange	CFM	1623	1586	1553	1511	1470	1433	1393	1350	1309	1261
			WATTS	285	299	312	324	335	349	363	378	393	407
			BHP	0.31	0.32	0.33	0.35	0.36	0.37	0.39	0.41	0.42	0.44
High	Black	CFM	1775	1736	1696	1660	1622	1588	1557	1516	1472	1426	
		WATTS	371	386	401	410	424	439	453	468	483	497	
		BHP	0.40	0.41	0.43	0.44	0.45	0.47	0.49	0.50	0.52	0.53	

Dry Coil Air Delivery* - Downflow Discharge

UNIT	MOTOR SPEED	WIRE COLOR	EXTERNAL STATIC PRESSURE (IN. W.C.)											
			0.10	0.20	0.30	0.40	0.50	0.60	0.70	0.80	0.90	1.0		
704D--A48	Low	Blue	CFM	1503	1457	1423	1374	1330	1287	1241	1199	1153	1111	
			WATTS	225	233	246	254	269	282	292	307	314	329	
	MedLow	Pink	CFM	1556	1508	1461	1432	1388	1346	1302	1256	1221	1168	
			WATTS	244	261	268	281	290	305	319	330	345	353	
	Medium ¹	Red	CFM	1661	1622	1586	1558	1516	1488	1460	1432	1404	1376	
			WATTS	400	417	426	441	452	467	482	492	507	519	
	MedHigh	Orange	CFM	1719	1679	1643	1614	1584	1554	1524	1494	1464	1434	
			WATTS	758	769	787	799	808	823	822	805	780	737	
	High	Black	CFM	1819	1778	1742	1712	1682	1652	1622	1592	1562	1532	
			WATTS	2532	2487	2444	2391	2330	2259	2179	2111	2033	1949	
	704D--A60	Low	Blue	CFM	1479	1436	1387	1346	1298	1253	1206	1160	1114	1061
				WATTS	224	239	247	262	270	284	300	307	319	330
MedLow		Pink	CFM	1841	1796	1761	1724	1690	1651	1616	1578	1527	1478	
			WATTS	425	434	453	460	476	485	501	508	525	542	
Medium ¹		Red	CFM	1944	1913	1872	1838	1801	1771	1731	1698	1655	1613	
			WATTS	486	501	511	529	537	554	565	578	595	603	
MedHigh		Orange	CFM	2178	2148	2105	2073	2036	2002	1967	1919	1845	1751	
			WATTS	674	691	703	717	733	743	758	754	734	701	
High		Black	CFM	2480	2432	2375	2322	2236	2161	2085	2006	1917	1808	
			WATTS	1029	1012	995	975	941	908	869	836	796	751	
			BHP	1.10	1.09	1.07	1.05	1.01	0.97	0.93	0.90	0.85	0.81	

*Air delivery values are without air filter and are for dry coil (See 704D--A Wet Coil Pressure Drop table).

¹ Factory-shipped cooling speed.

NOTE: Ducted field-supplied air filter pressure drop and wet coil pressure drop to obtain external static pressure available for ducting. Shaded areas indicate speed/static combinations that are not permitted.

Wet Coil Pressure Drop (IN. W.C.)

UNIT SIZE	STANDARD CFM (SCFM)																
	600	700	800	900	1000	1100	1200	1300	1400	1500	1600	1700	1800	1900	2000	2100	2200
24	0.03	0.04	0.04	0.05	0.06												
30				0.05	0.06	0.07	0.08	0.11									
36				0.06	0.06	0.09	0.10	0.11	0.14								
42					0.05	0.05	0.06	0.07	0.08	0.08	0.09	0.09	0.11				
48							0.04	0.06	0.09	0.10	0.10	0.11	0.12	0.13	0.14		
60										0.06	0.07	0.01	0.08	0.09	0.10	0.12	0.13

Economizer with 1-in. Filter Pressure Drop (IN. W.C.)

FILTER SIZE IN. (MM)	COOLING TONS	STANDARD CFM (SCFM)																
		600	700	800	900	1000	1100	1200	1300	1400	1500	1600	1700	1800	1900	2000	2100	2200
600-1400 CFM 12x20x1 + 12x20x1 (305x508x25+305x508x25)	2.0, 2.5, 3.0	-	-	0.09	0.14	0.16	0.18	0.25	0.28	0.3	-	-	-	-	-	-	-	-
1200-1800 CFM 16x24x1 + 14x24x1 (406x610x25+356x610x25)	3.5, 4.0	-	-	-	-	-	-	0.10	0.11	0.12	0.13	0.14	0.16	0.16	-	-	-	-
1500-2200 CFM 16x24x1 + 18x24x1 (406x610x25+457x610x25)	5.0	-	-	-	-	-	-	-	-	-	0.15	0.17	0.18	0.20	0.21	0.22	0.23	0.23

Filter Pressure Drop Table (IN. W.C.)

FILTER SIZE IN. (MM)	COOLING TONS	STANDARD CFM (SCFM)																
		600	700	800	900	1000	1100	1200	1300	1400	1500	1600	1700	1800	1900	2000	2100	2200
600-1400 CFM 12x20x1 + 12x20x1 (305x508x25+305x508x25)	2.0, 2.5, 3.0	0.03	0.05	0.06	0.08	0.10	0.11	0.13	0.14	0.16	-	-	-	-	-	-	-	-
1200-1800 CFM 16x24x1 + 14x24x1 (406x610x25+356x610x25)	3.5, 4.0	-	-	-	-	-	-	0.07	0.08	0.09	0.09	0.10	0.11	0.12	-	-	-	-
1500-2200 CFM 16x24x1 + 18x24x1 (406x610x25+457x610x25)	5.0	-	-	-	-	-	-	-	-	-	0.04	0.06	0.08	0.10	0.11	0.13	0.14	0.15

PERFORMANCE DATA (CONT)

**Electric Heat Pressure Drop (IN. W.C.)
Small Cabinet: 24-36**

	STANDARD CFM (SCFM)															
	500	600	700	800	900	1000	1100	1200	1300	1400	1500	1600				
5kw	0.00	0.00	0.00	0.00	0.00	0.00	0.00	0.00	0.02	0.02	0.03	0.04	0.05	0.05	0.06	0.07
7.5 kw	0.00	0.00	0.00	0.00	0.00	0.00	0.02	0.03	0.04	0.05	0.06	0.07	0.08	0.09	0.10	0.11
10 kw	0.00	0.00	0.00	0.00	0.00	0.02	0.04	0.06	0.07	0.09	0.10	0.11	0.12	0.13	0.14	0.15
15 kw	0.00	0.00	0.00	0.02	0.04	0.06	0.08	0.10	0.12	0.14	0.15	0.16	0.17	0.18	0.19	0.20
20 kw	0.00	0.00	0.02	0.04	0.06	0.08	0.09	0.11	0.13	0.15	0.17	0.18	0.19	0.20	0.21	0.22

**Electric Heat Pressure Drop (IN. W.C.)
Large Cabinet 42-60**

	STANDARD CFM (SCFM)															
	1100	1200	1300	1400	1500	1600	1700	1800	1900	2000	2100	2200	2300	2400	2500	
5kw	0.00	0.00	0.00	0.01	0.02	0.03	0.04	0.05	0.06	0.07	0.08	0.09	0.10	0.11	0.12	
7.5 kw	0.00	0.00	0.01	0.02	0.03	0.04	0.05	0.06	0.07	0.08	0.09	0.10	0.11	0.12	0.13	
10 kw	0.00	0.00	0.01	0.02	0.03	0.04	0.05	0.06	0.07	0.08	0.09	0.10	0.11	0.12	0.13	
15 kw	0.00	0.02	0.03	0.04	0.05	0.06	0.07	0.08	0.09	0.10	0.11	0.12	0.13	0.14	0.15	
20 kw	0.02	0.03	0.04	0.05	0.06	0.07	0.08	0.09	0.10	0.11	0.12	0.13	0.14	0.15	0.16	

TYPICAL PIPING AND WIRING

704D--A

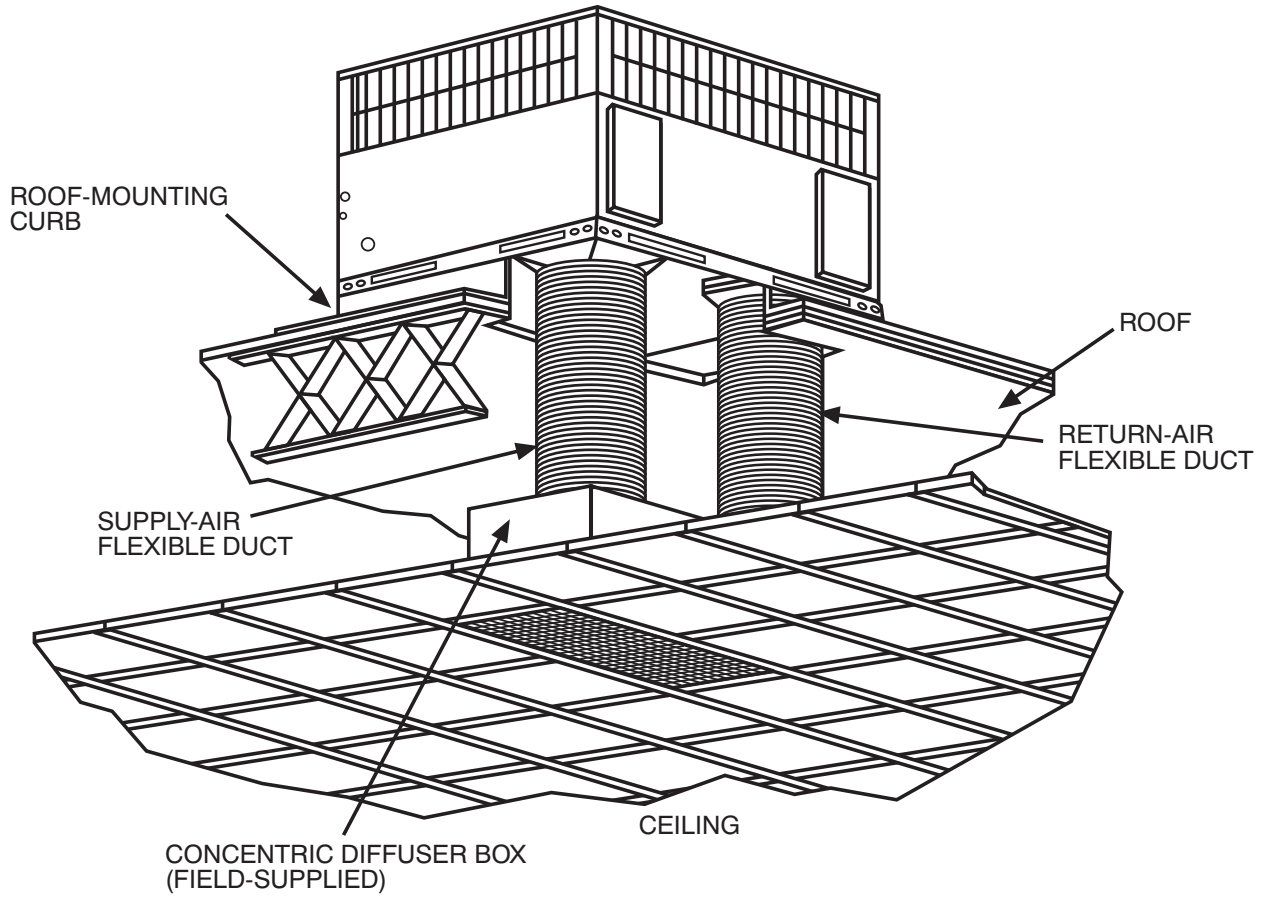

A09230

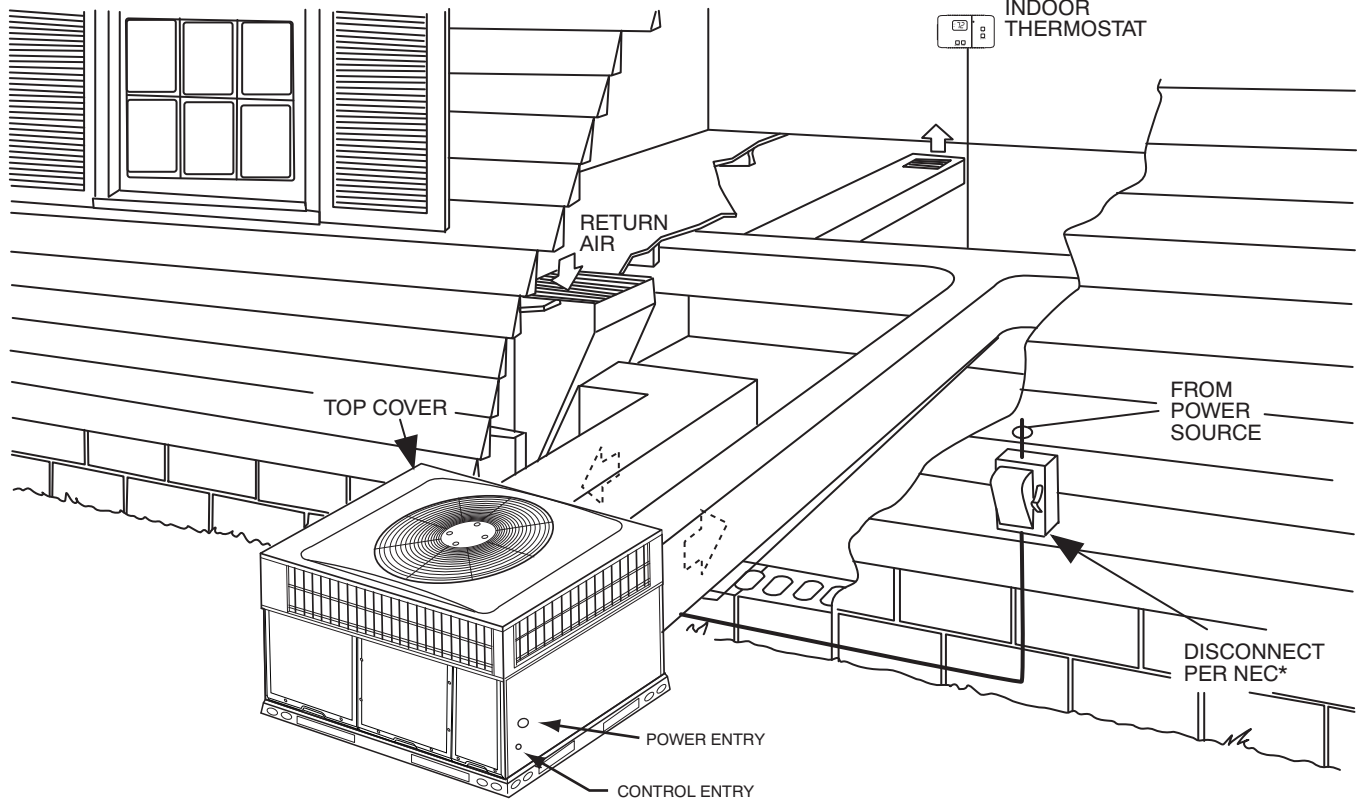

*NEC - National Electrical Code

A09240

APPLICATION DATA

Condensate trap — A 2-in. (50.8 mm) condensate trap must be field supplied.

Ductwork — Secure downflow discharge ductwork to roof curb. For horizontal discharge applications, attach ductwork to unit with flanges.

To convert a unit to downflow discharge — Units are equipped with factory-installed inserts in the downflow openings. Removal of the inserts is similar to removing an electrical knock-out.

Maximum cooling airflow — To minimize the possibility of condensate blow-off from the evaporator, airflow through the units should not exceed 450 cfm per ton.

Minimum cooling airflow — Minimum cooling airflow is 350 cfm per ton.

Minimum ambient cooling operation temperature — All standard units have a minimum ambient operating temperature of 40°F (4°C). With accessory low ambient temperature kit, units can operate at temperatures down to 0°F (-17°C).

ELECTRICAL DATA

704D--A

704D--A

UNIT	NOMINAL V- PH-HZ	VOLTAGE RANGE		COMPRESSOR		OFM	IFM	ELECTRIC HEAT			POWER SUPPLY				
		MIN	MAX	RLA	LRA	FLA	FLA	NOMINAL kW *	FLA			MCA			MOCSP
									208	240	460	208	230	460	
24	208/230-1-60	197	253	12.8	58.3	1.2	4.1	-/-	-	-	-	21.3	21.3	-	30
								3.8/5	18.1	20.8	-	27.8	31.1	-	30/35
								5.4/7.2	25.9	30.0	-	37.5	42.6	-	40/45
								7.5/10	36.1	41.7	-	50.3	57.3	-	60/60
30	208/230-1-60	197	253	12.8	64.0	1.2	4.1	-/-	-	-	-	21.3	21.3	-	30
								3.8/5	18.1	20.8	-	27.8	31.1	-	30/35
								5.4/7.2	25.9	30.0	-	37.5	42.6	-	40/45
								7.5/10	36.1	41.7	-	50.3	57.3	-	60/60
	208/230-3-60	197	253	8.4	58.0	1.2	4.1	-/-	-	-	-	15.8	15.8	-	20
								3.8/5	10.4	12.0	-	18.1	20.1	-	20/25
								7.5/10	20.8	24.1	-	31.1	35.3	-	35/40
								11.3/15	31.3	36.1	-	44.3	50.3	-	45/60
36	208/230-1-60	197	253	16.7	79.0	1.2	6.0	-/-	-	-	-	28.0	28.0	-	40
								3.8/5	18.1	20.8	-	30.1	33.5	-	40/40
								5.4/7.2	25.9	30.0	-	39.9	45.0	-	40/45
								7.5/10	36.1	41.7	-	52.6	59.6	-	60/60
	208/230-3-60	197	253	10.4	88.0	1.2	6.0	-/-	-	-	-	20.3	20.3	-	30
								3.8/5	10.4	12.0	-	20.5	22.5	-	30/30
								7.5/10	20.8	24.1	-	33.5	37.6	-	35/40
								11.3/15	31.3	36.1	-	46.6	52.6	-	50/60
	460-3-60	414	506	5.8	38.0	0.5	3.0	-	-	-	-	-	-	10.7	15
								5	-	-	6.0	-	-	11.3	15
								10	-	-	12.0	-	-	18.8	20
								15	-	-	18.0	-	-	26.3	30
42	208/230-1-60	197	253	17.9	112.0	1.2	6.0	-/-	-	-	-	29.6	29.6	-	40
								3.8/5	18.1	20.8	-	30.1	33.5	-	40/40
								5.4/7.2	25.9	30.0	-	39.9	45.0	-	40/45
								7.5/10	36.1	41.7	-	52.6	59.6	-	60/60
	208/230-3-60	197	253	13.5	88.0	1.2	6.0	-/-	-	-	-	24.1	24.1	-	35
								3.8/5	10.4	12.0	-	24.1	24.1	-	35/35
								7.5/10	20.8	24.1	-	33.5	37.6	-	35/40
								11.3/15	31.3	36.1	-	46.6	52.6	-	50/60
	460-3-60	414	506	6.0	44.0	0.5	3.0	-	-	-	-	-	-	11.0	15
								5	-	-	6.0	-	-	11.3	15
								10	-	-	12.0	-	-	18.8	20
								15	-	-	18.0	-	-	26.3	30
48	208/230-1-60	197	253	21.8	117.0	1.2	7.6	-/-	-	-	-	36.0	36.0	-	50
								3.8/5	18.1	20.8	-	36.0	36.0	-	50/50
								5.4/7.2	25.9	30.0	-	41.9	47.0	-	50/50
								7.5/10	36.1	41.7	-	54.6	61.6	-	60/70
	208/230-3-60	197	253	13.7	83.1	1.2	7.6	-/-	-	-	-	25.9	25.9	-	35
								3.8/5	10.4	12.0	-	25.9	25.9	-	35/35
								7.5/10	20.8	24.1	-	35.5	39.6	-	40/40
								11.3/15	31.3	36.1	-	48.6	54.6	-	50/60
	460-3-60	414	506	6.2	41.0	0.5	3.8	-	-	-	-	-	-	12.1	15
								5	-	-	6.0	-	-	12.3	15
								10	-	-	12.0	-	-	19.8	20
								15	-	-	18.0	-	-	27.3	30

ELECTRICAL DATA (CONT)

704D--A

UNIT	NOMINAL V- PH-HZ	VOLTAGE RANGE		COMPRESSOR		OFM	IFM	ELECTRIC HEAT			POWER SUPPLY				
		MIN	MAX	RLA	LRA	FLA	FLA	NOMINAL kW *	FLA			MCA			MOCP
									208	240	460	208	230	460	
60	208/230-1-60	197	253	26.4	134.0	1.2	7.6	-/-	-	-	-	41.8	41.8	-	60
								3.8/5	18.1	20.8	-	41.8	41.8	-	60/60
								5.4/7.2	25.9	30.0	-	41.9	47.0	-	60/60
								7.5/10	36.1	41.7	-	54.6	61.6	-	60/70
								11.3/15	54.2	62.5	-	77.3	87.6	-	80/90
	208/230-3-60	197	253	16.0	110.0	1.2	7.6	-/-	-	-	-	28.8	28.8	-	40
								3.8/5	10.4	12.0	-	28.8	28.8	-	40/40
								7.5/10	20.8	24.1	-	35.5	39.6	-	40/40
								11.3/15	31.3	36.1	-	48.6	54.6	-	50/60
								15/20	41.4	47.9	-	61.3	69.4	-	70/70
	460-3-60	414	506	7.8	52.0	0.5	3.8	-	-	-	-	-	-	14.0	20
								5	-	-	6.0	-	-	14.0	20
								10	-	-	12.0	-	-	19.8	20
								15	-	-	18.0	-	-	27.3	30
								20	-	-	24.1	-	-	34.9	35

* kW @ 208/240 or 480 volts

704D--A

LEGEND

- FLA - Full Load Amps
- IDM - Inducer Motor
- IFM - Indoor Fan Motor
- LRA - Locked Rotor Amps
- MCA - Minimum Circuit Amps
- MOCP - Maximum Over Current Protection
- OFM - Outdoor Fan Motor
- RLA - Rated Load Amps

NOTES:

- In compliance with NEC (National Electrical Code) requirements for multimotor and combination load equipment (refer to NEC Articles 430 and 440), the overcurrent protective device for the unit shall be Power Supply fuse or circuit breaker.
- Minimum wire size is based on 60 C copper wire. If other than 60 C wire is used, or if length exceeds wire length in table, determine size from NEC.
- Unbalanced 3-Phase Supply Voltage
Never operate a motor where a phase imbalance in supply voltage is greater than 2%. Use the following formula to determine the percentage of voltage imbalance

% Voltage imbalance

$$= 100 \times \frac{\text{max voltage deviation from average voltage}}{\text{average voltage}}$$

EXAMPLE: Supply voltage is 230-3-60.

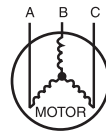

AB = 228 v
BC = 231 v
AC = 227 v

$$\text{Average Voltage} = \frac{228 + 231 + 227}{3}$$

$$= \frac{686}{3}$$

$$= 229$$

Determine maximum deviation from average voltage.

- (AB) 229 - 228 = 1 v
- (BC) 231 - 229 = 2 v
- (AC) 229 - 227 = 2 v

Maximum deviation is 2 v.

Determine percent of voltage imbalance

$$\% \text{ Voltage Imbalance} = 100 \times \frac{2}{229}$$

$$= 0.8\%$$

This amount of phase imbalance is satisfactory as it is below the maximum allowable 2%.

IMPORTANT: If the supply voltage phase imbalance is more than 2%, contact your local electric utility company immediately.

A06564

TYPICAL CONNECTION WIRING SCHEMATIC 208/230-1-60

CONNECTION WIRING DIAGRAM

DANGER: ELECTRICAL SHOCK HAZARD DISCONNECT POWER BEFORE SERVICING

SCHEMATIC
230-1-60

704D--A

FOR WIRING WITH ELECTRIC HEATERS, SEE SCHEMATIC ON HEATER ACCESSORY.

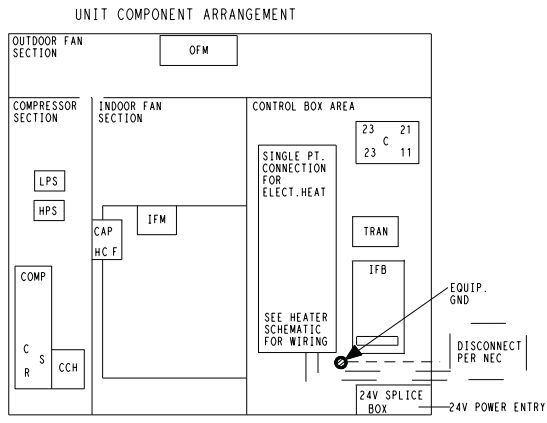
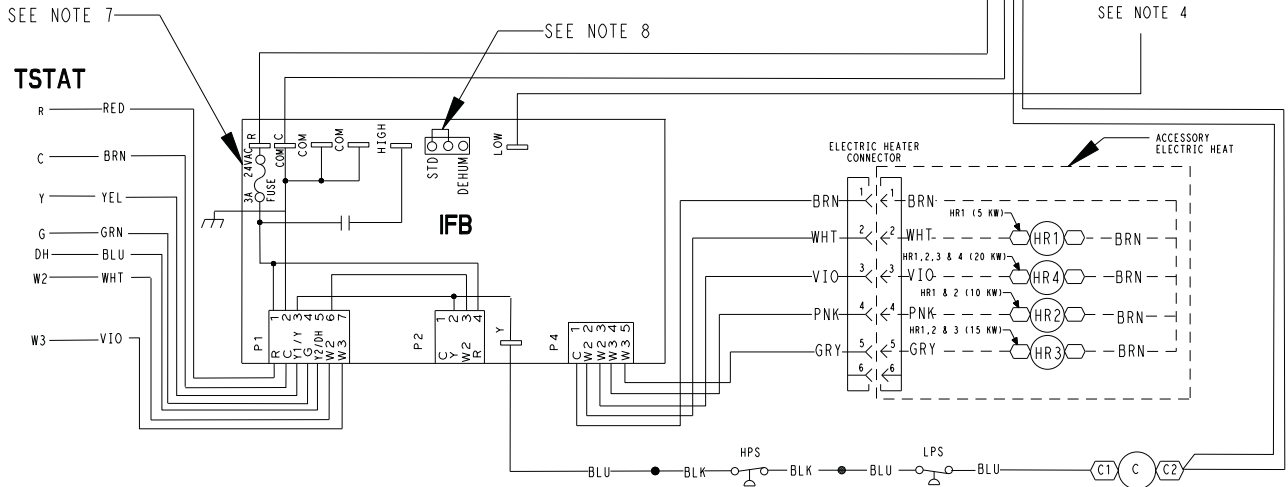
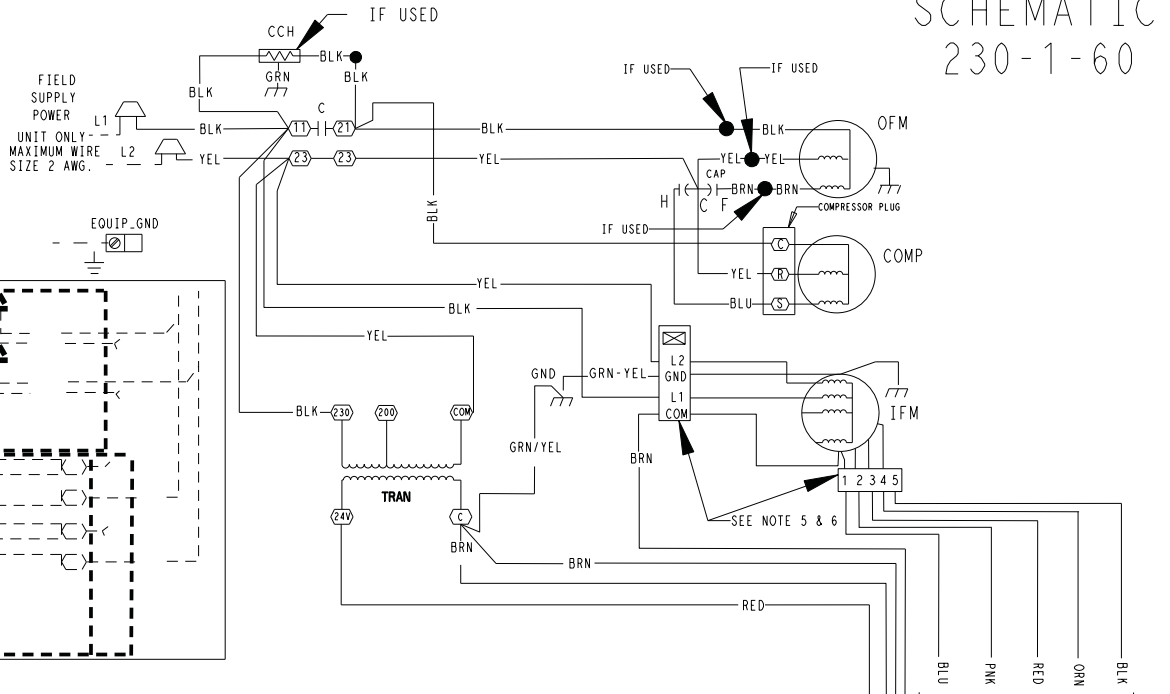

LEGEND

△	FIELD SPLICE	C	CONTACTOR
○	TERMINAL (MARKED) ENERGIZED	CAP	CAPACITOR
○	TERMINAL (UNMARKED)	CCH	CRANK CASE HEATER
●	SPLICE (IF USED)	COMP	COMPRESSOR MOTOR
○	SPLICE (MARKED)	DEHUM	DEHUMIDIFICATION MODE
---	FACTORY WIRING	GND	GROUND
---	FIELD CONTROL WIRING	HPS	HIGH PRESSURE SWITCH
---	FIELD POWER WIRING	HR	HEATER RELAY
---	ACCESSORY OR OPTIONAL WIRING	IFB	INTERFACE FAN BOARD
---	TO INDICATE COMMON POTENTIAL ONLY; NOT TO REPRESENT WIRING	IFM	INDOOR FAN MOTOR
		LPS	LOW PRESSURE SWITCH
		OFM	OUTDOOR FAN MOTOR
		STD	STANDARD
		TRAN	TRANSFORMER

- NOTES:**
- IF ANY OF THE ORIGINAL WIRES FURNISHED ARE REPLACED, IT MUST BE REPLACED WITH TYPE 90 DEGREE C WIRE OR IT'S EQUIVALENT.
 - SEE PRICE PAGES FOR THERMOSTAT AND SUBBASES.
 - USE 15 DEGREE COPPER CONDUCTORS FOR FIELD INSTALLATION.
 - REFER TO INSTALLATION INSTRUCTIONS FOR CORRECT SPEED SELECTION OF IFM.
 - RELOCATION OF SPEED TAPS MAY BE REQUIRED WHEN USING FIELD INSTALLED ELECTRIC HEATERS. CONSULT INSTALLATION INSTRUCTIONS TO DETERMINE CORRECT SPEED TAP SETTING.
 - "DO NOT DISCONNECT PLUG UNDER LOAD."
 - THIS FUSE IS MANUFACTURED BY LITTELFUSE, P/N 257003.
 - UNIT FACTORY-SHIPED IN STD MODE.

TYPICAL LADDER WIRING SCHEMATIC 208/230-1-60

LADDER WIRING DIAGRAM

DANGER: ELECTRICAL SHOCK HAZARD DISCONNECT POWER BEFORE SERVICING

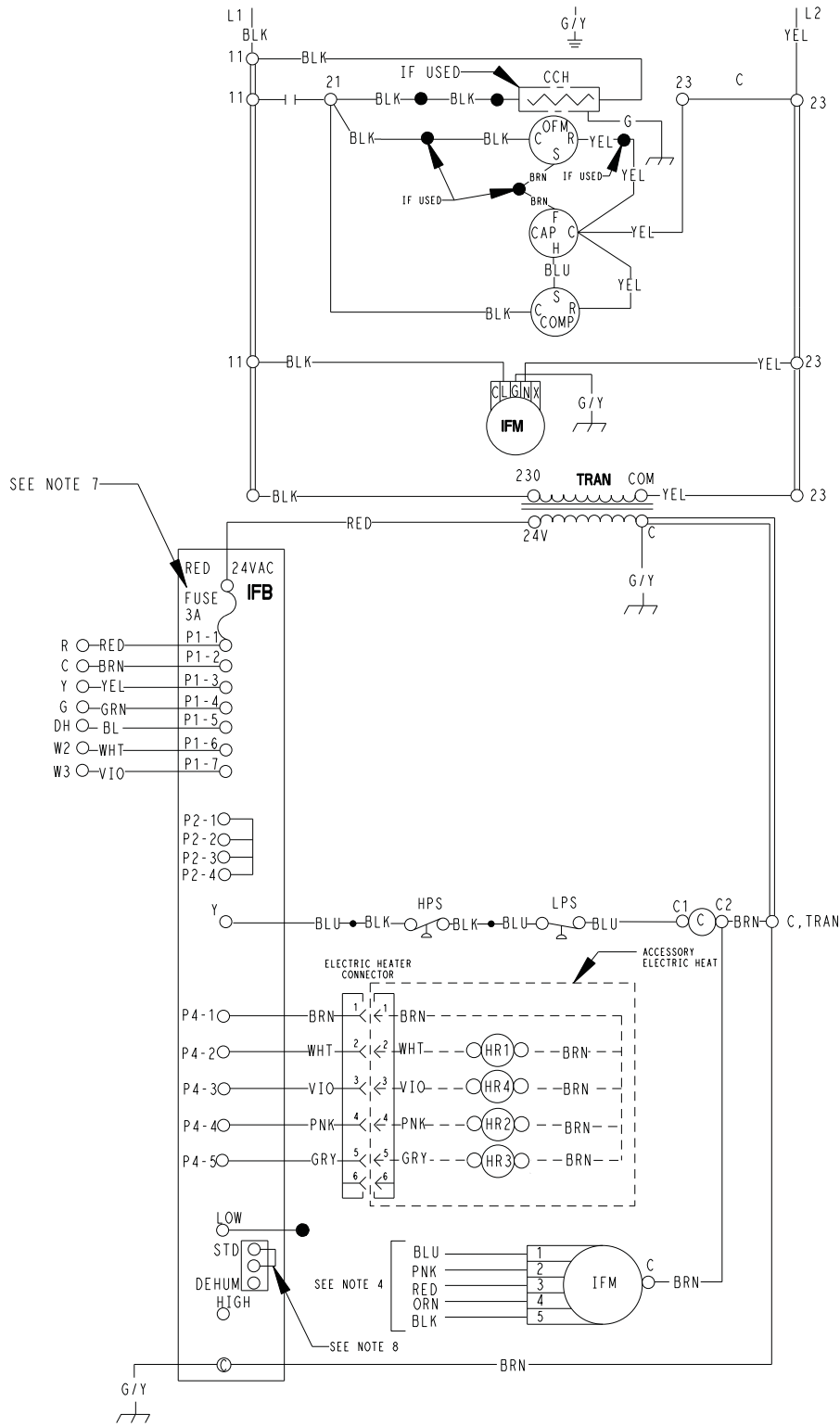

704D--A

50VL500269

E

A11003

TYPICAL CONNECTION WIRING SCHEMATIC 208/230-3-60

CONNECTION WIRING DIAGRAM

DANGER: ELECTRICAL SHOCK HAZARD DISCONNECT POWER BEFORE SERVICING

SCHEMATIC
230-3-60

704D--A

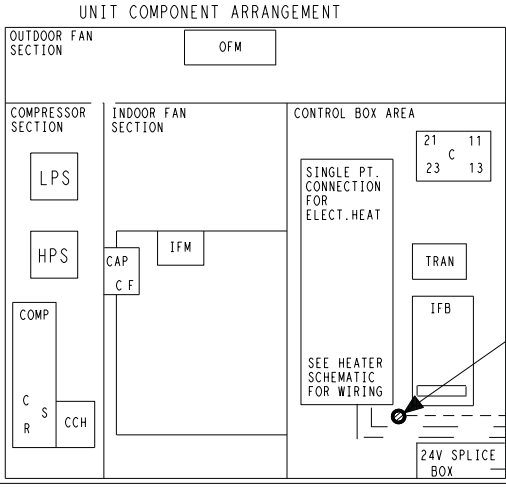
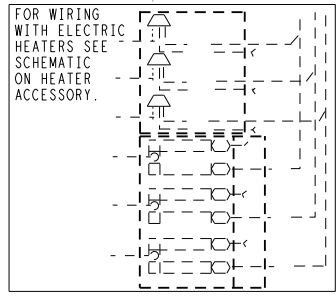
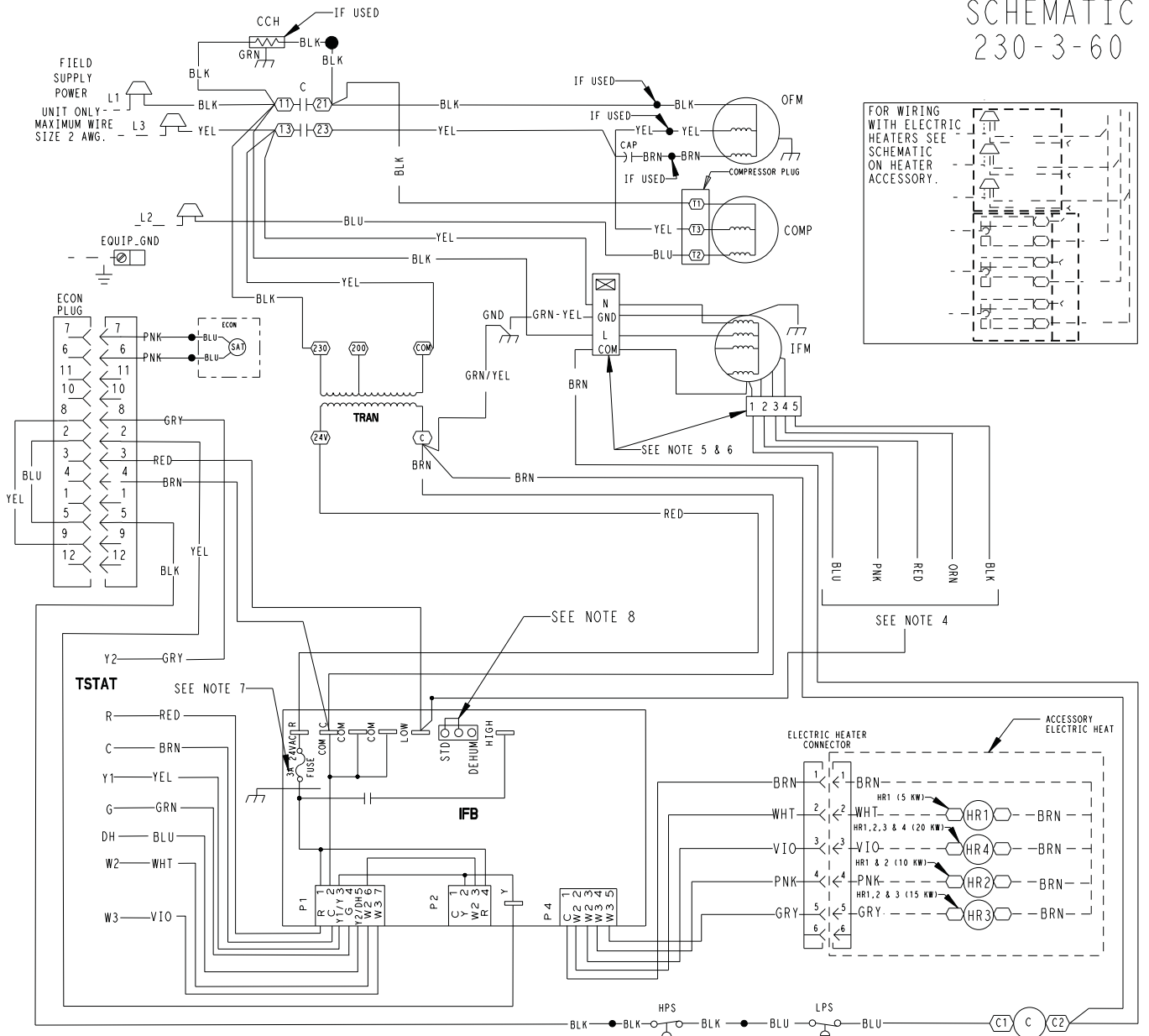

LEGEND

△	FIELD SPLICE	C	CONTACTOR
○	TERMINAL (MARKED) ENERGIZED	CAP	CAPACITOR
○	TERMINAL (UNMARKED)	COMP	COMPRESSOR MOTOR
●	SPLICE (IF USED)	DH	DEHUMIDIFICATION MODE
○	SPLICE (MARKED)	DEHUM	DEHUMIDIFICATION MODE
—	FACTORY WIRING	ECON	ECONOMIZER
---	FIELD CONTROL WIRING	GND	GROUND
---	FIELD POWER WIRING	HPS	HIGH PRESSURE SWITCH
---	ACCESSORY OR OPTIONAL WIRING	HR	HEATER RELAY
---	TO INDICATE COMMON POTENTIAL ONLY; NOT TO REPRESENT WIRING	IFB	INTERFACE FAN BOARD
		IFM	INDOOR FAN MOTOR
		LPS	LOW PRESSURE SWITCH
		OFM	OUTDOOR FAN MOTOR
		STD	STANDARD MODE
		TRAN	TRANSFORMER

- NOTES:**
- IF ANY OF THE ORIGINAL WIRES FURNISHED ARE REPLACED, THEY MUST BE REPLACED WITH THE SAME WIRE OR IT'S EQUIVALENT.
 - SEE PRICE PAGES FOR THERMOSTATS.
 - USE 75 DEGREE COPPER CONDUCTORS FOR FIELD INSTALLATION.
 - REFER TO INSTALLATION INSTRUCTIONS FOR CORRECT SPEED SELECTION OF IFM.
 - RELOCATION OF SPEED TAPS MAY BE REQUIRED WHEN USING FIELD INSTALLED ELECTRIC HEATERS. CONSULT INSTALLATION INSTRUCTIONS TO DETERMINE CORRECT SPEED TAP SETTING.
 - DO NOT DISCONNECT PLUG UNDER LOAD.
 - THIS FUSE IS MANUFACTURED BY LITTELFUSE, P/N 257003.
 - DEHUM FEATURE CANNOT BE USED WHEN ECONOMIZER IS INSTALLED. UNIT FACTORY-SHIPED IN STD MODE.

TYPICAL LADDER WIRING SCHEMATIC 208/230-3-60

LADDER WIRING DIAGRAM

DANGER: ELECTRICAL SHOCK HAZARD DISCONNECT POWER BEFORE SERVICING

704D--A

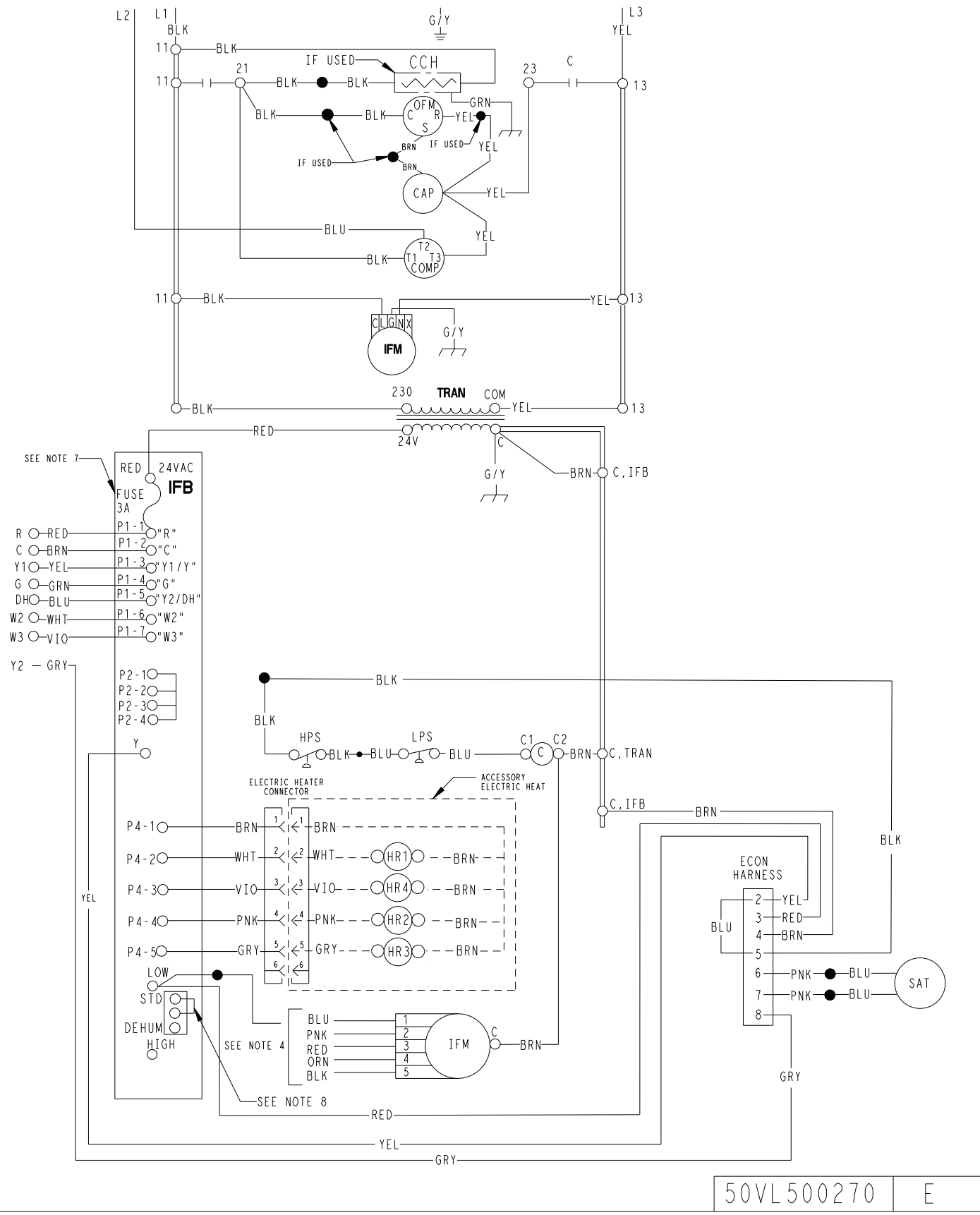

50VL500270 E

TYPICAL CONNECTION WIRING SCHEMATIC 460-3-60

CONNECTION WIRING DIAGRAM

DANGER: ELECTRICAL SHOCK HAZARD DISCONNECT POWER BEFORE SERVICING

SCHEMATIC
460-3-60

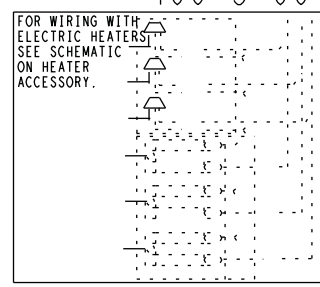
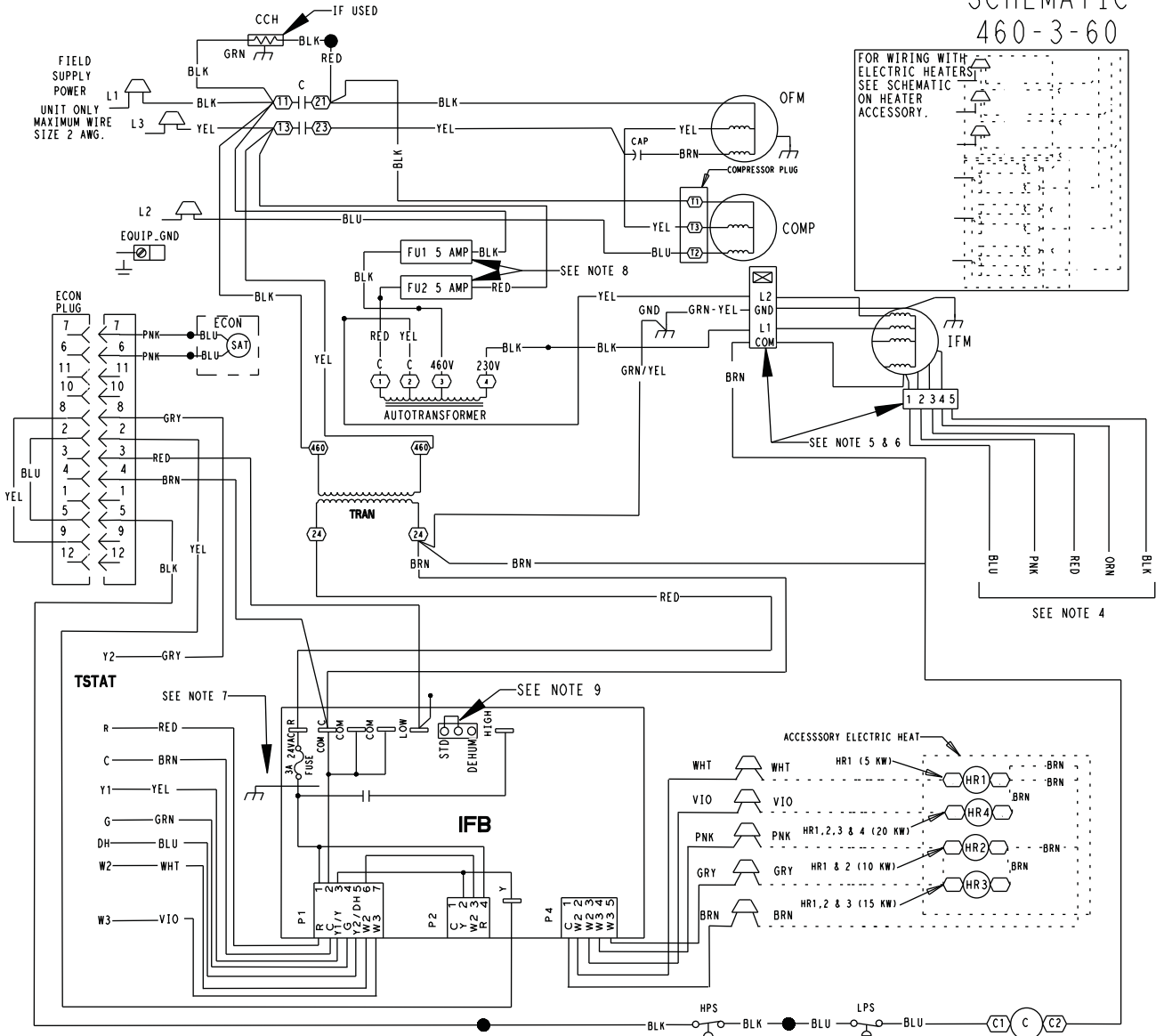

704D--A

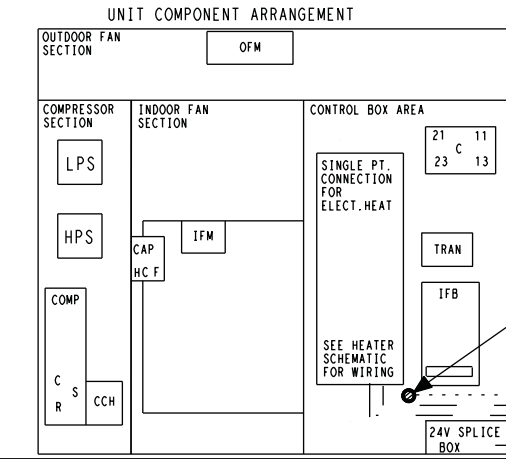

LEGEND

△	FIELD SPLICE	C	CONTACTOR
○	TERMINAL (UNMARKED)	CAP	CAPACITOR
●	TERMINAL (MARKED) ENERGIZED	COMP	COMPRESSOR MOTOR
○	SPLICE (IF USED)	DH	DEHUMIDIFICATION MODE
○	SPLICE (MARKED)	DEHUM	DEHUMIDIFICATION MODE
—	FACTORY WIRING	ECON	ECONOMIZER
- - -	FIELD CONTROL WIRING	GND	GROUND
- · - · -	FIELD POWER WIRING	HPS	HIGH PRESSURE SWITCH
- · - · -	ACCESSORY OR OPTIONAL WIRING	HR	HEATER RELAY
—	TO INDICATE COMMON	IFB	INTERFACE FAN BOARD
○	POTENTIAL ONLY:	IFM	INDOOR FAN MOTOR
○	NOT TO REPRESENT WIRING	LPS	LOW PRESSURE SWITCH
		OFM	OUTDOOR FAN MOTOR
		STD	STANDARD WIRE
		TRAN	TRANSFORMER

- NOTES:**
- IF ANY OF THE ORIGINAL WIRES FURNISHED ARE REPLACED, IT MUST BE REPLACED WITH TYPE 90 DEGREE C WIRE OR IT'S EQUIVALENT.
 - SEE PRICE PAGES FOR THERMOSTAT AND SUBBASES.
 - USE 75 DEGREE COPPER CONDUCTORS FOR FIELD INSTALLATION.
 - REFER TO INSTALLATION INSTRUCTIONS FOR CORRECT SPEED SELECTION OF IFM.
 - RELOCATION OF SPEED TAPS MAY BE REQUIRED WHEN USING FIELD INSTALLED ELECTRIC HEATERS. CONSULT INSTALLATION INSTRUCTIONS TO DETERMINE CORRECT SPEED TAP SETTING.
 - "DO NOT DISCONNECT PLUG UNDER LOAD."
 - THIS FUSE IS MANUFACTURED BY LITTELFUSE, P/N 257003
 - THESE FUSES ARE MANUFACTURED BY COOPER BUSSMAN, P/N FNO-R-5
 - DEHUM FEATURE CANNOT BE USED WHEN ECONOMIZER IS INSTALLED.
 - UNIT FACTORY-SHIPED IN STD. MODE.

TYPICAL LADDER WIRING SCHEMATIC 460-3-60

LADDER WIRING DIAGRAM

DANGER: ELECTRICAL SHOCK HAZARD DISCONNECT POWER BEFORE SERVICING

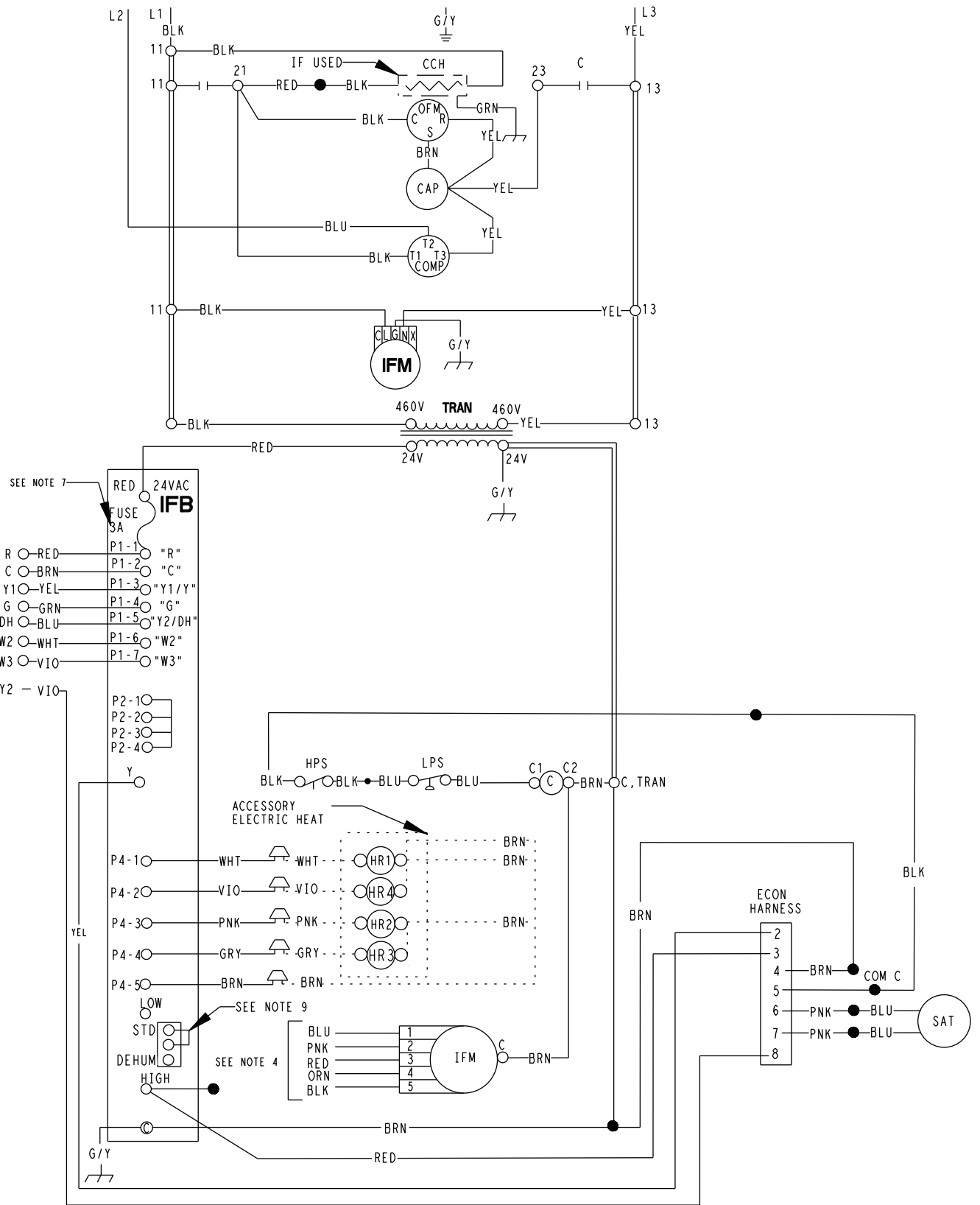

704D--A

50VL500271 D

A10204L

CONTROLS

Operating sequence

Cooling — When the system thermostat calls for cooling, 24 V is supplied to the “Y” and “G” terminals of the thermostat. This completes the circuit to the contactor coil (C) and indoor (evaporator) fan motor (IFM). The normally open contacts of C close and complete the circuit through compressor motor (COMP) to outdoor (condenser) fan motor (OFM). Both motors start instantly. Simultaneously, 24 volts is supplied through G to the Interface Fan Board (IFB) and to the IFM. The IFM starts instantly. On the loss of the thermostat call for cooling, 24 V is removed from both the “Y” and “G” terminals (provided the fan switch is in the “AUTO” position) de-energizing the compressor contactor and opening the contacts supplying power to compressor/OFM. After a 90-second delay, the IFM shuts off. If the thermostat fan selector switch is in the “ON” position, the IFM will run continuously. For the 460 V units there is a step down autotransformer supplying 230 V to the Indoor Fan Motor.

NOTE: On units with a Time Guard® II device: Once the compressor has started and then stopped, it cannot be restarted again until 5 minutes have elapsed.

Heating — If accessory electric heaters are installed, on a call for heat, circuit R-W is made through the thermostat contacts. Circuit R-G is made which energizes the IFM. If the heaters are staged, then the thermostat closes a second set of contacts (W2) when second stage is required. When thermostat is satisfied, contacts open, deenergizing the heater relay and the IFM.

GUIDE SPECIFICATIONS

Packaged Electric Cooling Unit

Constant Volume Application

HVAC Guide Specifications

Size Range: **2 to 5 Tons, Nominal Cooling**

Model Number: 704D--A

Part 1 — General

SYSTEM DESCRIPTION

Outdoor rooftop mounted or ground mounted, electric cooling unit utilizing a hermetic scroll compressor for cooling duty. Unit shall discharge supply air vertically or horizontally as shown on contract drawings. Condenser fan/coil section shall have a draw-thru design with vertical discharge for minimum sound levels.

QUALITY ASSURANCE

- A. Unit shall be rated in accordance with AHRI Standards 210/240 and 270.**
- B. Unit shall be designed in accordance with UL Standard 1995.**
- C. Unit shall be manufactured in a facility registered to ISO 9001 manufacturing quality standard.**
- D. Unit shall be UL listed and c-UL certified as a total package for safety requirements.**
- E. Roof curb shall be designed to conform to NRCA Standards.**
- F. Insulation and adhesives shall meet NFPA 90A requirements for flame spread and smoke generation.**
- G. Cabinet insulation shall meet ASHRAE Standard 62P.**

DELIVERY, STORAGE AND HANDLING

Unit shall be stored and handled per manufacturer's recommendations.

Part 2 — Products

EQUIPMENT

A. General:

Factory-assembled, single-piece, heating and cooling unit. Contained within the enclosure shall be all factory wiring, piping, controls, refrigerant charge with R-410A refrigerant, and special features required prior to field start-up.

B. Unit Cabinet:

- 1. Unit cabinet shall be constructed of phosphated, zinc-coated, pre-painted steel capable of with-standing 500 hours in salt spray.
- 2. Normal service shall be through a 3 removable cabinet panels.
- 3. The unit shall be constructed on a rust proof unit base that has an externally trapped, integrated sloped drain.
- 4. Evaporator fan compartment top surface shall be insulated with a minimum 1/2-in. (12.7 mm) thick, flexible fiberglass insulation, coated on the air side and retained by adhesive and mechanical means. The evaporator wall sections will be insulated with a minimum semi-rigid foil-faced board capable of being wiped clean. Aluminum foil-faced fiberglass insulation shall be used in the entire indoor air cavity section.
- 5. Unit shall have a field-supplied condensate trap.

C. Fans:

- 1. The evaporator fan motor shall be ECM Motor, as shown on equipment drawings.
- 2. Fan wheel shall be made from steel, be double-inlet type with forward curved blades with corrosion resistant finish. Fan wheel shall be dynamically balanced.

- 3. Condenser fan shall be direct drive propeller type with aluminum blades riveted to corrosion resistant steel spiders, be dynamically balanced, and discharge air vertically.

D. Compressor:

- 1. Fully hermetic compressors with factory-installed vibration isolation.
- 2. Scroll compressors shall be standard on all units.

E. Coils:

Evaporator and condenser coils shall have aluminum plate fins mechanically bonded to seamless copper tubes with all joints brazed. Tube sheet openings shall be belled to prevent tube wear.

F. Refrigerant Components:

Refrigerant expansion device shall be of the TXV (thermostatic expansion valve) type.

G. Filters:

Filter section shall consist of field-installed, throwaway, 1-in. (25 mm) thick fiberglass filters of commercially available sizes.

H. Controls and Safeties:

- 1. Unit controls shall be complete with a self-contained low voltage control circuit.
- 2. Units shall incorporate high and low pressure switches.

I. Operating Characteristics:

- 1. Unit shall be capable of starting and running at 125°F (51°C) ambient outdoor temperature per maximum load criteria of AHRI Standard 210.
- 2. Compressor with standard controls shall be capable of operation down to 40°F (4°C) ambient outdoor temperature.
- 3. Unit shall be provided with 60-second fan time delay after the thermostat is satisfied.

J. Electrical Requirements:

All unit power wiring shall enter the unit cabinet at a single location.

K. Motors:

- 1. Compressor motors shall be of the refrigerant-cooled type with line-break thermal and current overload protection.
- 2. All fan motors shall have permanently lubricated bearings, and inherent, automatic reset, thermal overload protection.
- 3. Condenser fan motor shall be totally enclosed.
- 4. Evaporator fan motor to be ECM motor.

L. Special Features:

- 1. Coil Options:
Base unit with tin plated indoor coil hairpins available as a factory installed option.
- 2. Compressor Start Kit (single phase units only):
Shall provide additional starting torque for single-phase compressors.
- 3. Thermostat:
To provide for one-stage heating and cooling in addition manual or automatic changeover and indoor fan control.
- 4. Crankcase Heater:
Shall provide anti-floodback protection for low-load cooling applications.

GUIDE SPECIFICATIONS (CONT)

5. Economizer:
(Horizontal - field installed accessory)
(Vertical - field installed accessory or factory installed option)
- Economizer controls capable of providing free cooling using outside air.
 - Equipped with low leakage dampers not to exceed 3% leakage, at 1.0 IN. W.C. pressure differential.
 - Spring return motor shuts off outdoor damper on power failure.
6. Electric Heaters:
- Electric heater shall be available as a field-installed option.
 - Heater elements shall be open wire type, adequately supported and insulated with ceramic bushings.
 - Electric heater packages must provide single point power connection capability.
7. Filter Rack Kit:
Shall provide filter mounting for downflow applications. Offered as an accessory or as a factory installed option.
8. Flat Roof Curb:
Curbs shall have seal strip and a wood nailer for flashing and shall be installed per manufacturer's instructions.
9. Low Ambient Package:
Shall consist of a solid-state control and condenser coil temperature sensor for controlling condenser-fan motor operation, which shall allow unit to operate down to 0°F (-17°C) outdoor ambient temperature when properly installed.
10. Louvered Grille:
Wire grille shall be standard on all units. Louvered grille shall be available as a field-installed option to provide hail guard and vandalism protection.
11. Manual Outdoor Air Damper:
Package shall consist of damper, birdscreen, and rainhood which can be preset to admit outdoor air for year-round ventilation.
12. Square-To-Round Duct Transitions (24-48 size):
Shall have the ability to convert the supply and return openings from rectangular to round.
13. Time Guard II
Automatically prevents the compressor from restarting for at least 4 minutes and 45 seconds after shutdown of the compressor. Not required when a corporate programmable thermostat is applied.