

## Product Data

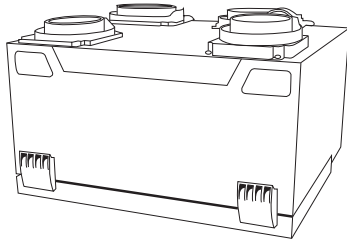

**ERVXXSVB1100, HRVXXSVB1100**

A05229

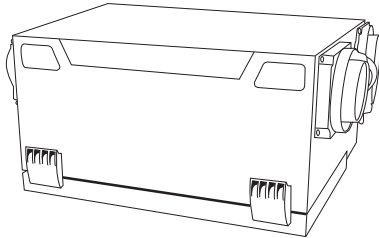

**ERVXXSHB1100, HRVXXSHB1100**

A05330

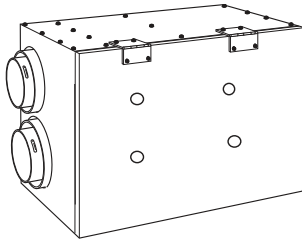

**ERVXXLHB1200, HRVXXLHB1150, HRVXXLHB1250**

A10299

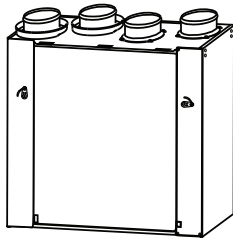

**HRVXXSVU1157**

A12338

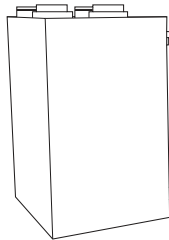

**HRVXXLVU1330**

A12339

The Heat Recovery Ventilation (HRV) and Energy Recovery Ventilator (ERV) systems offered by Bryant are the finest on the market today. These units provide efficient and cost effective heat recovery during the heating season when needed most.

As temperatures drop below 23°F (-5°C), indoor air is recirculated periodically through the heat exchanger core to prevent frost from forming. Competitors' methods of supplementary electric defrost waste energy. Unlike rotary wheel heat exchangers which mix air streams, these cross-flow or counterflow heat exchangers ensure that there is no mixing of the stale air stream with the fresh outdoor air stream.

A filter installed on the incoming outdoor air stream removes large airborne particles from the intake air stream before they enter the heat exchanger and reduces the maintenance required. The units' acoustically engineered design make Bryant ventilators the quietest on the market and ensures that comfort is felt, not heard.

Unlatching two (2) suitcase style latches allows easy removal of the filters and core for cleaning on most units.

**NOTE:** The unit should not be installed in an attic or unconditioned space unless provisions are made for drain line freezing and condensation.

### STANDARD FEATURES

#### HRV

- Energy saving defrost cycle
- Cross-flow, counterflow heat exchangers
- One filter on incoming air; one filter on outgoing air to protect core
- Acoustical design
- Polypropylene heat exchanger core

#### ERV

- Integrated airflow balancing points
- Integrated furnace interlock
- High pressure blowers
- Onboard control for continuous high/low ventilator operation
- Energy saving defrost cycle
- Cross-flow, counterflow heat exchangers
- One filter on incoming air; one filter on outgoing air to protect core
- No-tools maintenance
- Enthalpic heat exchanger core

# MODEL NUMBER NOMENCLATURE

ERV	XX	LHB	1	150
<b>PRODUCT TYPE</b> ERV – Energy Recovery Ventilator HRV – Heat Recovery Ventilator			<b>CFM</b>	
<b>BRAND</b> XX – Dual Branded Installer selects and applies logo badge			<b>VOLTAGE</b> 1 – 115/60/1	
			<b>STYLE</b> LHB – Large Horizontal, End Ports HRV – 150, 250 cfm ERV – 200 cfm SVB – Small Horizontal, Top Vertical Ports HRV & ERV – 100 cfm SHB – Small Horizontal, End Ports HRV & ERV – 100 cfm SVU – Vertical, Top Ports HRV – 157 cfm LVU – Large Vertical, Top Ports HRV – 330 cfm	

Energy Star Canada:  
 All units in this document meet Energy Star Tier 2 requirements in Canada except HRVXXLVU1330 and ERVXXLHB1200



These products earned the ENERGY STAR® by meeting strict energy efficiency guidelines set by Natural Resources Canada and the US EPA. They meet ENERGY STAR requirements only when used in Canada.



## Climate Map for Energy and Heat Recovery Ventilators

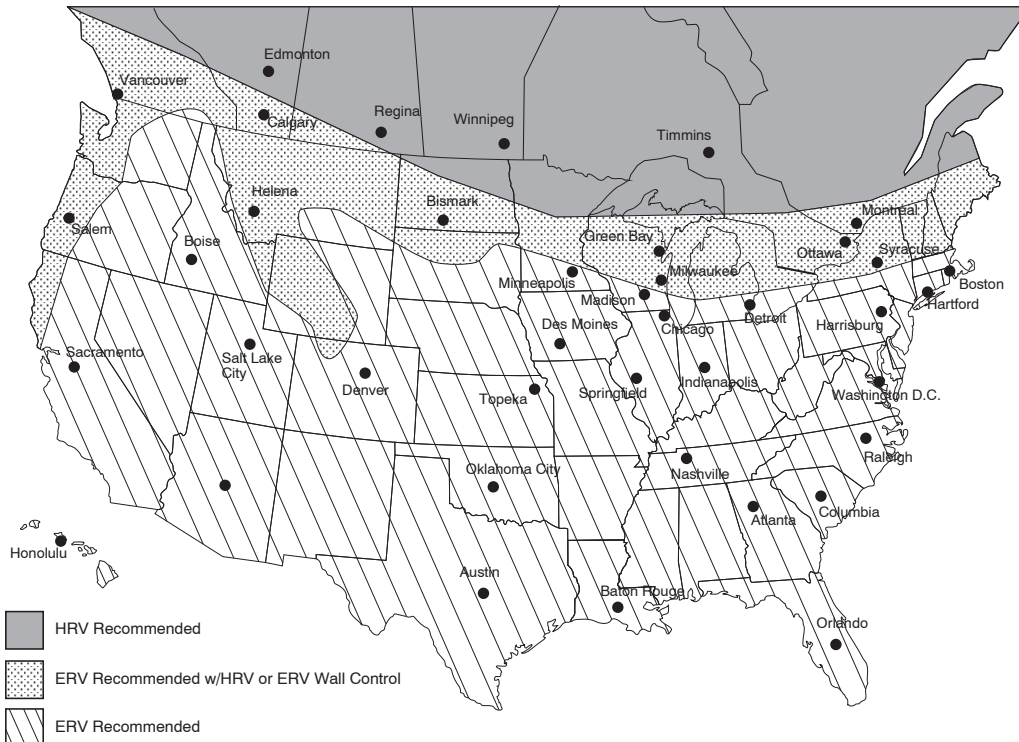

# ERVXXSVB1100, HRVXXSVB1100

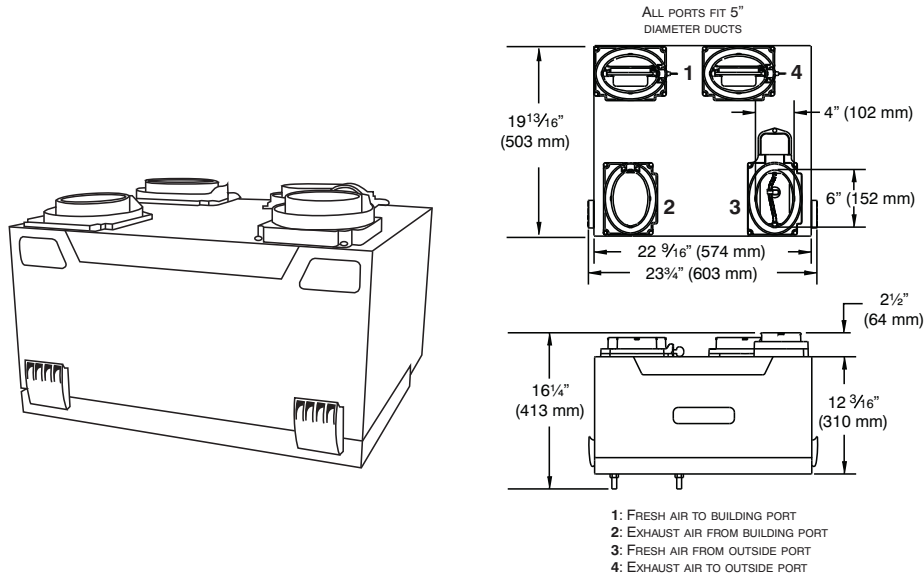

A12327

## PHYSICAL & ELECTRICAL DATA

MODEL	CAPACITY (LO-HI)		PORT LOC.	CORE		WEIGHT LBS. [KG]	VOLTAGE	MAX POWER WATTS	MAX AMPS
	CFM	L/S		TYPE	AIR FLOW				
ERVXXSVB1100	35 - 105	17 - 50	Top	Enthalpic transfer media	Cross Flow	45 [20]	115/60/1	104	1.0
HRVXXSVB1100	35 - 105	17 - 50	Top	Polypropylene	Cross Flow	42 [19]	115/60/1	100	0.85

## DEFROST OPERATION

MODEL	OUTSIDE TEMPERATURE		DEFROST CYCLE (MIN.)	
	°C	°F	Defrosting	Operation Time Between Each Defrost Cycle
ERVXXSVB1100	-5 to -27	23 to -17	9	28
	Below -27	Below -17	10	22
HRVXXSVB1100	-5 to -27	23 to -17	8	25
	Below -27	Below -17	10	22

## HVI RATED ENERGY PERFORMANCE

MODEL	MODE	SUPPLY TEMP		NET AIR FLOW		POWER CONSUMED (WATTS)	SENSIBLE RECOVERY EFFICIENCY	APPARENT SENSIBLE EFFECTIVENESS	LATENT RECOVERY MOISTURE TRANSFER	TOTAL RECOVERY EFFICIENCY
		°C	°F	L/S	CFM					
ERVXXSVB1100	Heat	0	32	23	49	42	67	79	0.61	
		0	32	30	64	60	65	75	0.55	
		0	32	40	84	72	63	71	0.48	
	Cool	-25	-13	21	45	58	60	75	0.60	
		35	95	21	44	42				50
HRVXXSVB1100	Heat	0	32	23	50	43	65	74	0.01	
		0	32	30	64	58	62	70	0.01	
		0	32	39	83	70	59	66	0.01	
		-25	-13	21	45	56	60	78	0.01	
	Cool	35	95							

## VENTILATION PERFORMANCE

MODEL	EXT. STATIC PRESSURE		NET SUPPLY AIR FLOW		GROSS AIR FLOW			
	Pa	In w.g.	L/S	CFM	SUPPLY		EXHAUST	
					L/S	CFM	L/S	CFM
ERVXXSVB1100	25	0.1	54	115	55	117	55	117
	50	0.2	53	112	54	115	54	114
	100	0.4	49	105	50	106	50	106
	200	0.8	42	89	43	92	42	88
	250	1.0	38	81	39	82	38	81
HRVXXSVB1100	25	0.1	53	111	53	112	57	120
	50	0.2	51	107	51	108	54	114
	100	0.4	46	98	47	99	49	105
	200	0.8	37	79	38	80	40	85
	250	1.0	34	71	34	72	36	76

NOTE: For additional data points, refer to HVI Directory at [www.hvi.org](http://www.hvi.org)

# ERVXXSHB1100, HRVXXSHB1100

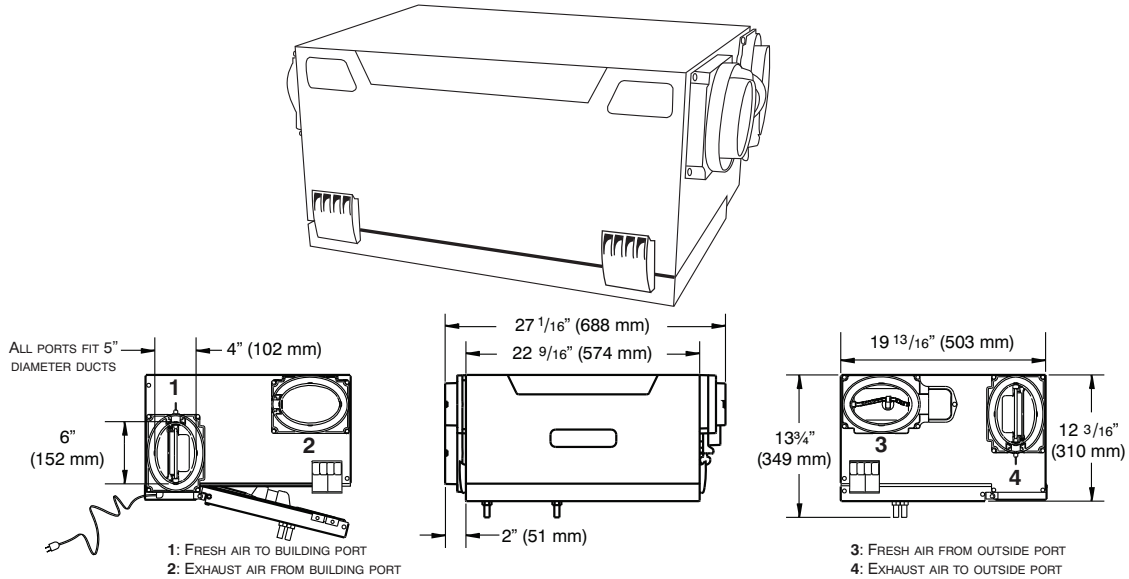

A12328

## PHYSICAL & ELECTRICAL DATA

MODEL	CAPACITY (LO-HI)		PORT LOC.	CORE		WEIGHT LBS. [KG]	VOLTAGE	MAX POWER WATTS	MAX AMPS
	CFM	L/S		TYPE	AIR FLOW				
ERVXXSHB1100	35 - 105	17 - 50	Ends	Enthalpic transfer media	Cross Flow	45 [20]	115/60/1	104	1.0
HRVXXSHB1100	35 - 105	17 - 50	Ends	Polypropylene	Cross Flow	42 [19]	115/60/1	100	0.85

## DEFROST OPERATION

MODEL	OUTSIDE TEMPERATURE		DEFROST CYCLE (MINUTES)	
	°C	°F	Defrosting	Operation Time Between Each Defrost Cycle
ERVXXSHB1100	-5 to -27	23 to -17	9	28
	Below -27	Below -17	10	22
HRVXXSHB1100	-5 to -27	23 to -17	8	25
	Below -27	Below -17	10	22

## HVI RATED ENERGY PERFORMANCE

MODEL	MODE	SUPPLY TEMP		NET AIR FLOW		POWER CONSUMED (WATTS)	SENSIBLE RECOVERY EFFICIENCY	APPARENT SENSIBLE EFFECTIVENESS	LATENT RECOVERY MOISTURE TRANSFER	TOTAL RECOVERY EFFICIENCY
		°C	°F	L/S	CFM					
ERVXXSHB1100	Heat	0	32	23	49	42	67	79	0.61	
		0	32	30	64	60	65	75	0.55	
		0	32	40	84	72	63	71	0.48	
	Cool	-25	-13	21	45	58	60	75	0.60	
		35	95	21	44	42				50
HRVXXSHB1100	Heat	0	32	23	50	43	65	74	0.01	
		0	32	30	64	58	62	70	0.01	
		0	32	39	83	70	59	66	0.01	
	Cool	-25	-13	21	45	56	60	78	0.01	
		35	95							

## VENTILATION PERFORMANCE

MODEL	EXT. STATIC PRESSURE		NET SUPPLY AIR FLOW		GROSS AIR FLOW			
	Pa	In w.g.	SUPPLY		EXHAUST		L/S	CFM
			L/S	CFM	L/S	CFM		
ERVXXSHB1100	25	0.1	54	115	55	117	55	117
	50	0.2	53	112	54	115	54	114
	100	0.4	49	105	50	106	50	106
	200	0.8	42	89	43	92	42	88
HRVXXSHB1100	25	0.1	53	111	53	112	57	120
	50	0.2	51	107	51	108	54	114
	100	0.4	46	98	47	99	49	105
	200	0.8	37	79	38	80	40	85
	250	1.0	34	71	34	72	36	76

NOTE: For additional data points, refer to HVI Directory at [www.hvi.org](http://www.hvi.org)

## ERVXXLHB1200, HRVXXLHB1150, HRVXXLHB1250

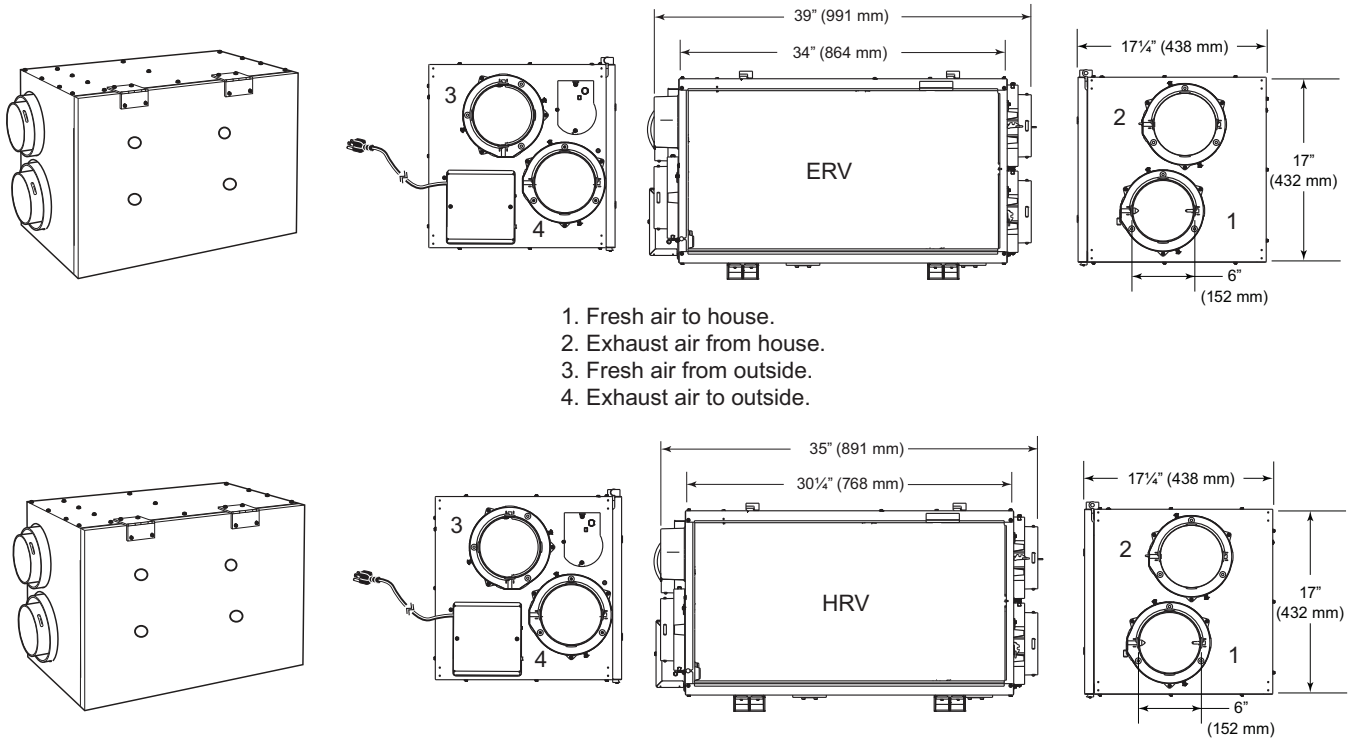

A12341

### PHYSICAL & ELECTRICAL DATA

MODEL	CAPACITY (LO-HI)		PORT LOC.	CORE		WEIGHT LBS. [KG]	VOLTAGE	MAX POWER WATTS	MAX AMPS
	CFM	L/S		TYPE	AIR FLOW				
ERVXXLHB1200	80 – 198	38 – 93	Ends	Enthalpic transfer media	Cross flow	76 [35]	115/60/1	200	2.1
HRVXXLHB1150	66 – 163	31 – 77	Ends	Polypropylene	Cross flow	65 [30]	115/60/1	160	1.5
HRVXXLHB1250	82 – 204	39 – 96	Ends	Polypropylene	Cross flow	65 [30]	115/60/1	195	2.1

### DEFROST OPERATION

MODEL	OUTSIDE TEMPERATURE		DEFROST CYCLE (MIN.)		EXTENDED DEFROST CYCLES (MIN.)	
	°C	°F	Defrosting	Operation Time Between Each Defrost Cycle	Defrosting	Operation Time Between Each Defrost Cycle
ERVXXLHB1200	-5	23	10	60	10	30
	-15	5	10	30	10	20
	-27	-17	10	20	10	15
HRVXXLHB1150	-5	23	7	50	10	30
	-15	5	7	25	10	20
	-27	-17	10	20	10	15
HRVXXLHB1250	-5	23	6	50	10	30
	-15	5	6	25	10	20
	-27	-17	10	20	10	15

**ERVXXLHB1200, HRVXXLHB1150, HRVXXLHB1250 (cont.)**

**HVI RATED ENERGY PERFORMANCE**

MODEL	MODE	SUPPLY TEMP		NET AIR FLOW		POWER CONSUMED (WATTS)	SENSIBLE RECOVERY EFFICIENCY	APPARENT SENSIBLE EFFECTIVENESS	LATENT RECOVERY MOISTURE TRANSFER	TOTAL RECOVERY EFFICIENCY
		°C	°F	L/S	CFM					
ERVXXLHB1200	Heat	0	32	39	80	84	60	72	0.60	
		0	32	54	114	113	58	69	0.53	
		0	32	79	167	169	56	66	0.45	
		-25	-13	31	65	116	41	86	0.47	
	Cool	35	95	39	82	81				52
HRVXXLHB1150	Heat	0	32	31	66	67	67	79	0	
		0	32	40	86	74	65	75	0	
		0	32	54	115	90	61	70	0	
		-25	-13	38	81	87	60	76	0.02	
	Cool	35	95							
HRVXXLHB1250	Heat	0	32	39	82	71	65	75	0.01	
		0	32	61	130	129	60	69	0.01	
		-25	-13	40	84	114	60	76	0.03	
	Cool	35	95							

**VENTILATION PERFORMANCE**

MODEL	EXT. STATIC PRESSURE		NET SUPPLY AIR FLOW		GROSS AIR FLOW			
	Pa	In w.g.	L/S	CFM	SUPPLY		EXHAUST	
					L/S	CFM	L/S	CFM
ERVXXLHB1200	25	0.1	105	222	106	225	106	225
	75	0.3	93	198	94	200	100	212
	100	0.4	86	183	88	186	93	198
	150	0.6	70	148	71	150	75	158
	200	0.8	50	107	51	108	29	61
HRVXXLHB1150	25	0.1	85	180	86	182	92	194
	75	0.3	77	163	77	164	81	171
	100	0.4	71	150	71	151	71	151
	150	0.6	60	128	61	130	40	85
	175	0.7	51	108	52	110	27	57
HRVXXLHB1250	25	0.1	106	225	107	227	118	249
	75	0.3	96	204	97	205	111	235
	100	0.4	90	192	91	193	107	226
	150	0.6	76	161	76	162	89	189
	175	0.7	67	142	67	143	75	159

**NOTE:** For additional data points, refer to HVI Directory at [www.hvi.org](http://www.hvi.org)

# HRVXXSVU1157

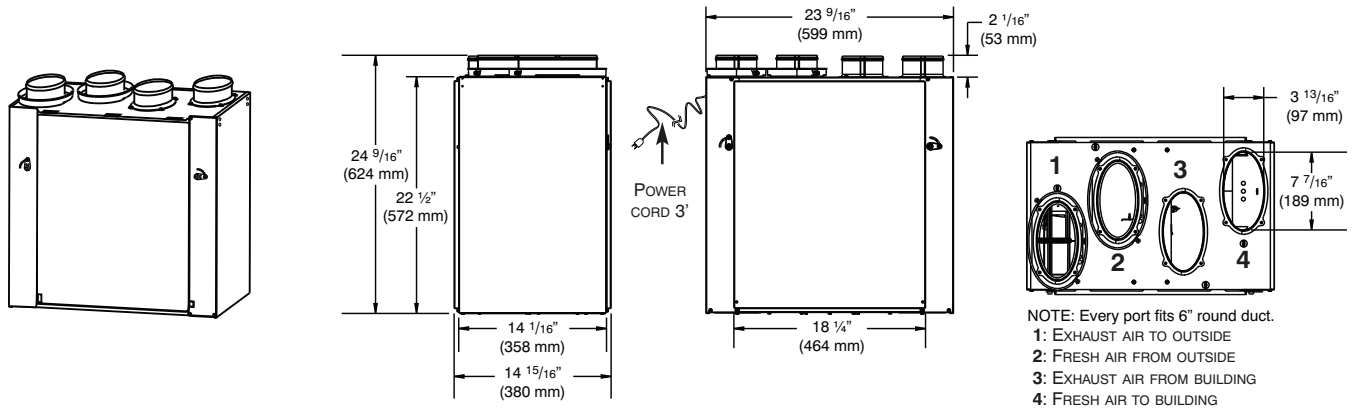

A12331

## PHYSICAL & ELECTRICAL DATA

MODEL	CAPACITY (LO-HI)		PORT LOC.	CORE		WEIGHT LBS. [KG]	VOLTAGE	MAX POWER WATTS	MAX AMPS
	CFM	L/S		TYPE	AIR FLOW				
HRVXXSVU1157	67 - 170	32 - 80	Top	Polypropylene	Cross flow	56 [25]	115/60/1	125	1.0

## DEFROST OPERATION

MODEL	OUTSIDE TEMPERATURE		DEFROST CYCLE (MINUTES)	
	°C	°F	Defrosting	Exchange
HRVXXSVU1157	-5 to -15	23 to 55	7	25
	-16 to -27	4 to -17	7	25
	Below -27	Below -17	10	22

## HVI RATED ENERGY PERFORMANCE

MODEL	MODE	SUPPLY TEMP		NET AIR FLOW		POWER CONSUMED (WATTS)	SENSIBLE RECOVERY EFFICIENCY	APPARENT SENSIBLE EFFECTIVENESS	LATENT RECOVERY MOISTURE TRANSFER
		°C	°F	L/S	CFM				
HRVXXSVU1157	Heat	0	32	32	67	56	70	78	0.00
		0	32	40	86	64	68	75	0.01
		0	32	56	120	86	64	70	0.01
		-25	-13	30	63	79	61	83	0.01

## VENTILATION PERFORMANCE

MODEL	EXT. STATIC PRESSURE		NET SUPPLY AIR FLOW		GROSS AIR FLOW			
	Pa	In w.g.	L/S	CFM	Supply		Exhaust	
					L/S	CFM	L/S	CFM
HRVXXSVU1157	25	0.1	91	193	92	195	91	194
	75	0.3	80	170	81	171	80	169
	100	0.4	74	157	74	158	74	157
	150	0.6	62	132	62	133	63	133
	200	0.8	47	101	48	101	49	104

# HRVXXLVU1330

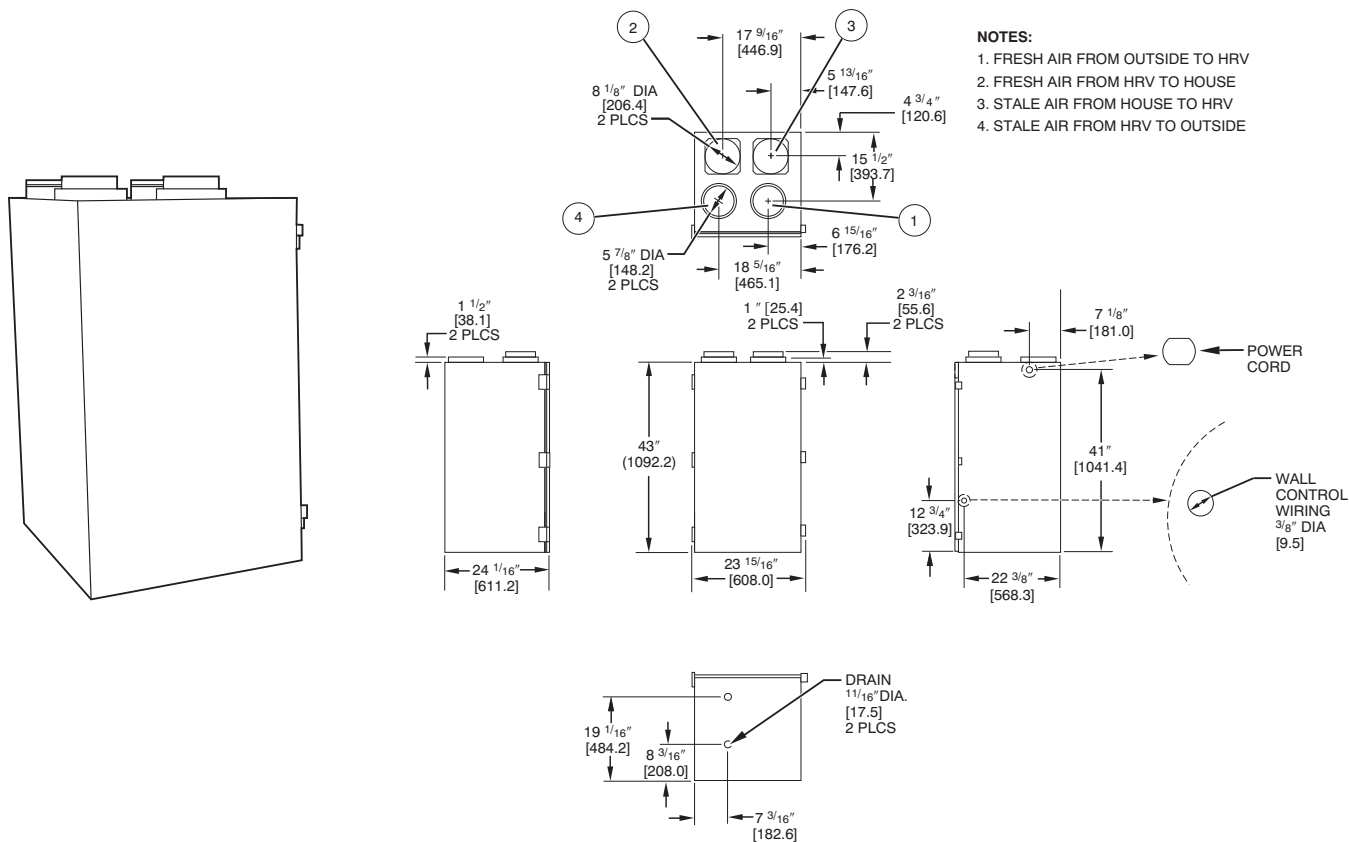

A12332

## PHYSICAL & ELECTRICAL DATA

MODEL	CAPACITY (LO-HI)		PORT LOC.	CORE		WEIGHT LBS. [KG]	VOLTAGE	MAX POWER WATTS	MAX AMPS
	CFM	L/S		TYPE	AIR FLOW				
HRVXXLVU1330	300 - 334	142 - 158	Top	Polypropylene	Cross flow	145 [66]	115/60/1	500	5.4

## DEFROST OPERATION

MODEL	OUTSIDE TEMPERATURE		DEFROST CYCLE (MINUTES)	
	°C	°F	Defrosting	Exchange
HRVXXLVU1330	-5 to -15	23 to 55	6	60
	-16 to -27	4 to -17	6	32
	Below -27	Below -17	6	20

## HVI RATED ENERGY PERFORMANCE

MODEL	MODE	SUPPLY TEMP		NET AIR FLOW		POWER CONSUMED (WATTS)	SENSIBLE RECOVERY EFFICIENCY	APPARENT SENSIBLE EFFECTIVENESS	LATENT RECOVERY MOISTURE TRANSFER
		°C	°F	L/S	CFM				
HRVXXLVU1330	Heat	0	32	55	117	219	80	94	-0.07
		0	32	86	183	290	74	86	0.02
		0	32	117	249	436	70	83	-0.01
		-25	-13	115	117	264	74	89	0.07

## VENTILATION PERFORMANCE

MODEL	EXT. STATIC PRESSURE		NET SUPPLY AIR FLOW		GROSS AIR FLOW			
	Pa	In w.g.	L/S	CFM	Supply		Exhaust	
					L/S	CFM	L/S	CFM
HRVXXLVU1330	25	0.1	168	357	172	364	148	314
	75	0.3	158	334	160	340	132	279
	100	0.4	151	321	155	328	126	266
	150	0.6	136	288	139	294	109	232
	200	0.8	126	246	118	251	93	198



## METHOD TO SIZE ERVs and HRVs

### Ventilator Sizing

Tables 1 and 2 should be used to determine the required airflow for a home. These guidelines are taken from ASHRAE 62.2-2007.

**Table 1 – Ventilation Air Requirements, cfm**

FLOOR AREA (ft <sup>2</sup> )	BEDROOMS				
	0-1	2-3	4-5	6-7	>7
<1500	30	45	60	75	90
1501-3000	45	60	75	90	105
3001-4500	60	75	90	105	120
4501-6000	75	90	105	120	135
6001-7500	90	105	120	135	150
>7500	105	120	135	150	165

**Table 2 – Ventilation Air Requirements, L/s**

FLOOR AREA (m <sup>2</sup> )	BEDROOMS				
	0-1	2-3	4-5	6-7	>7
<139	14	21	28	35	42
139.1-279	21	28	35	42	50
279.1-418	28	35	42	50	57
418.1-557	35	42	50	57	64
557.1-697	42	50	57	64	71
>697	50	57	64	71	78

## HEATING AND COOLING LOAD CHARTS

Although the ventilators process the outside air before it enters the home, additional heating and cooling loads need to be considered.

### HEATING LOAD BTUH (APPROXIMATE)

OUTSIDE TEMPERATURE		HEATING LOAD (BTUH) @ INSIDE DESIGN TEMPERATURE 72° F (21°C)								
Deg. C	Deg. F	HRV						ERV		
		SVB1100	SHB1100	SVU1157	LHB1150	LHB1250	LVU1330	SVB1100	SHB1100	LHB1200
-32	-25	4778	4778	7690	6636	10603	9990	4071	4071	8143
-29	-20	4531	4531	7090	6294	10057	9310	3861	3861	7723
-26	-15	4285	4285	6520	5952	9510	8650	3983	3983	7967
-23	-10	4039	4039	5970	5610	8964	8000	3759	3759	7509
-21	-5	3800	3800	5440	5268	8417	7380	3525	3525	7051
-18	0	3410	3410	4840	4925	7871	6640	3297	3297	6594
-15	5	3095	3095	4360	4583	7324	6060	3323	3323	6647
-12	10	2795	2795	3900	4241	6777	5500	3215	3215	6430
-9	15	2465	2465	3400	3899	6231	4870	3107	3107	6214
-7	20	2195	2195	3000	3557	5684	4350	2834	2834	5669
-4	25	1935	1935	2610	3215	5138	3850	2562	2562	5124
-1	30	1680	1680	2250	2873	4591	3370	2289	2289	4579
2	35	1425	1425	1880	2531	4045	2870	2017	2017	4034
4	40	1200	1200	1560	2189	3498	2430	1744	1744	3489

### COOLING LOAD BTUH (APPROXIMATE)

Outside Enthalpy	Cooling Load (btuh) @ Inside Design Temperature 72°F (21°C) and 50% Relative Humidity								
	HRV						ERV		
	Btu/lb	SVB1100	SHB1100	SVU1157	LHB1150	LHB1250	LVU1330	SVB1100	SHB1100
30	482	482	990	670	1071	1390	320	320	640
31	785	785	1650	1090	1741	2310	520	520	1040
32	1086	1086	2310	1509	2411	3240	720	720	1441
33	1388	1388	2970	1928	3080	4170	920	920	1841
34	1690	1690	3630	2347	3750	5090	1120	1120	2241
35	1992	1992	4290	2766	4419	6020	1320	1320	2641
36	2293	2293	4950	3185	5089	6940	1520	1520	3041
37	2595	2595	5610	3604	5759	7870	1720	1720	3441
38	2897	2897	6270	4023	6428	8790	1921	1921	3842
39	3198	3198	6930	4442	7098	9720	2121	2121	4242
40	3478	3478	7590	4831	7767	10650	2321	2321	4642
41	3802	3802	8250	5280	8437	11570	2521	2521	5042
42	4103	4103	8910	5699	9107	12500	2721	2721	5442

### HEATING LOAD BTUH

The heating load chart shows the heating loads in Btuh for a range of winter design temperatures for each model of ventilator.

### COOLING LOAD BTUH

The cooling load chart shows loads in Btuh as well. To use the cooling load chart, first find the design enthalpy from a psychrometric chart using the design dry bulb and wet bulb temperatures. The cooling load can then be found for a range of enthalpies for each ventilator.

**Ventilator installed with forced air system**

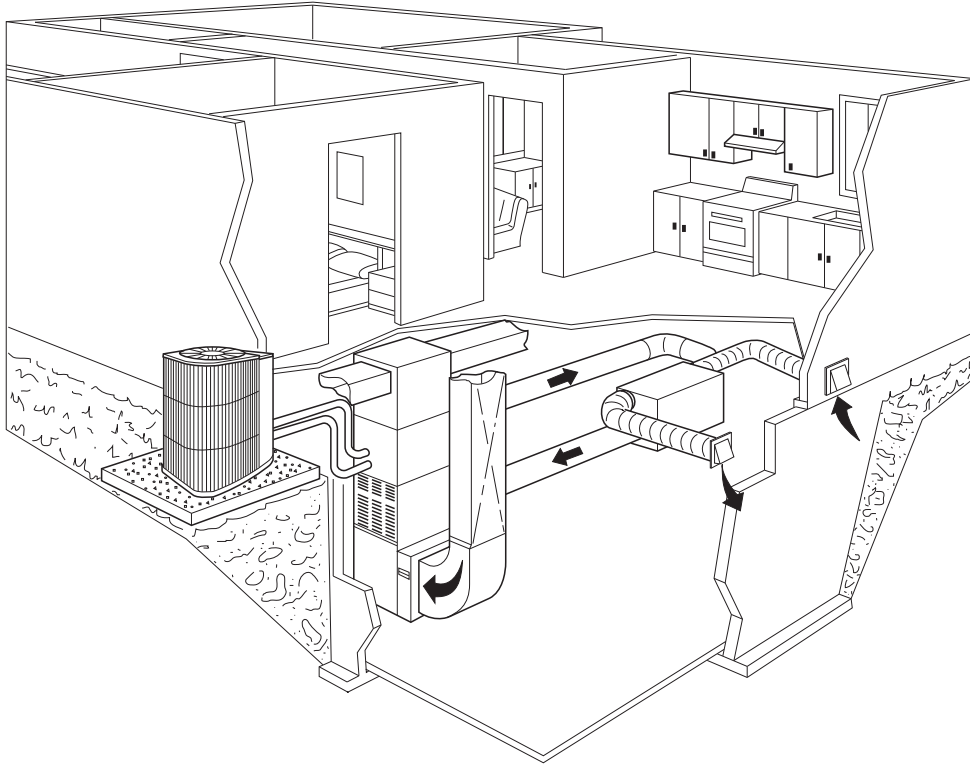





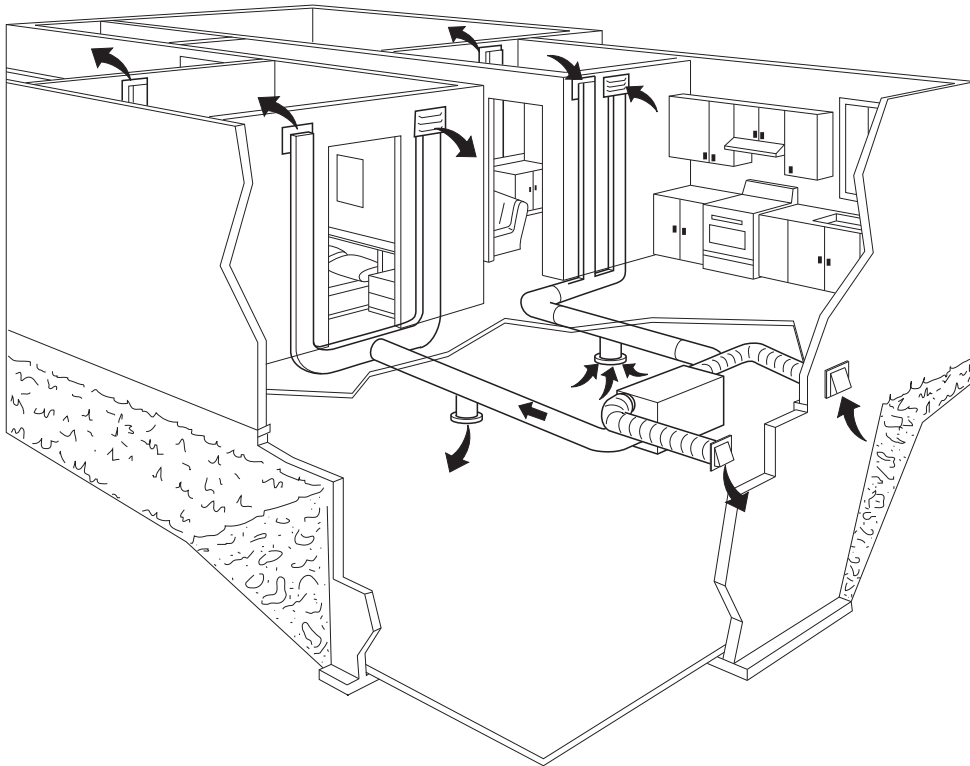

A99297

**Ventilator installed with independent air distribution**

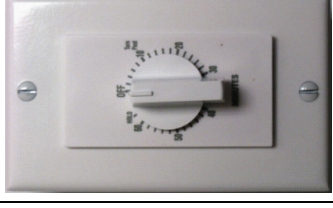

A99298

## BRYANT VENTILATOR CONTROLS COMPATIBILITY MATRIX

Control	Main Controls					Auxiliary Controls	
							
Name	One-Touch KVBCN0101BLT	Econo (Basic) KVBCN0101BBS	Standard (HRV) KVBCN0101BST	Standard Latent (ERV) KVACN0101BLC	Auto KVBCN0101BAU	60 min. Crank Timer KVATM010160M	20 min. Push Button KVATM010120B
Bryant Part #	KVBCN0101BLT	KVBCN0101BBS	KVBCN0101BST	KVACN0101BLC	KVBCN0101BAU	KVATM010160M	KVATM010120B
Main features	OFF-min-max-intermittent- lighted button	OFF-min-max	OFF-min-intermittent-dehumidistat	OFF-min-intermittent-dehumidistat	OFF-recirc-max-intermittent-dehumidistat	Allows up to 60 min of high speed	20-min high speed lighted push-button
Modes	Off, Intermittent (20 min. low, 40 min. off), Low continuous, High continuous	Off, Low continuous, High continuous, No humidistat.	Off, Low continuous, Intermittent, High speeded when humidity is above setpoint	Off, Low continuous, Intermittent, High speeded when humidity is below setpoint	Off, Low continuous, 20 min. on / 40 min. off. Recirculation. Dehumidistat turns unit on high if humidity levels rise above set level.	Overrides main wall control. Vent. will operate in high for 20 minutes unless button is pressed before 20 minutes expires, then turns unit off. Up to 5 secondary controls may be connected to a single ventilator.	Overrides main wall control. Vent. will operate in high for 20 minutes unless button is pressed before 20 minutes expires, then turns unit off. Up to 5 secondary controls may be connected to a single ventilator.
ERV/XXSHB1100	•			•		•	•
ERV/XXSVB1100	•					•	•
HRV/XXSHB1100	•	•				•	•
HRV/XXSVB1100	•	•				•	•
HRV/XXSVU1157	•	•		•		•	•
ERV/XXLHB1200	•					•	•
HRV/XXLHB1150	•	•			•	•	•
HRV/XXLHB1250	•	•			•	•	•
HRV/XXLVU1330	•	•			•	•	•

## ACCESSORIES

### VENTILATOR ACCESSORY NUMBER NOMENCLATURE

	1	2	3	4	5	6	7	8	9	10	11	12
	K	V	B	C	N	0	1	0	1	B	B	S
<b>Product</b>  KV - Ventilator Accessory Kit												
<b>Series</b> A - Original Series B - Second Series												
<b>Type</b> AC01 - Accessory CN01 - Control TM01 - Timer AC01 - Accessory												
<b>Package Quantity</b> 01 - Single Pack												

**Control Description**  
 BAU - Bryant Automatic Control  
 BBS - Bryant Basic Control  
 BLC - Bryant Latent Control  
 BLT - Bryant OneTouch Control  
 BST - Bryant Standard Control

**Accessory Description**  
 HOD - Intake Hood  
 KIT - Airflow Measuring Kit  
 6FM - Flow Collar 6-in.  
 7FM - Flow Collar 7-in.  
 8FM - Flow Collar 8-in.

**Timer Description**  
 120B - 20 Minute Timer Kit  
 160M - 60 Minute Timer Kit

KIT NUMBER	DESCRIPTION	WHERE USED
KVBCN0101BAU	Automatic Wall Control	Used with HRVs
KVBCN0101BBS	Basic Wall Control	Used with HRVs
KVBCN0101BLC	Latent Wall Control	Used with ERVs
KVBCN0101BLT	Bryant OneTouch Control	Used with ERVs and HRVs as a main wall control
KVBCN0101BST	Standard HRV Control	Used with HRVs
KVAAC0101HOD	Exterior Intake and Exhaust Hood	Used with ERVs and HRVs, 2 Required
KVAC0101KIT	Airflow Measuring Kit	Start up Balancing Kit, includes (2) 6 in. Flow Meter Collars & Magnehelic Gauge
KVATM010120C	20 Minute Push Button Timer	Used with ERVs and HRVs when 20 minute manual operation is required
KVATM010160M	60 Minute Timer	Used with ERVs and HRVs, time is adjustable between 10 and 60 minutes
KVAAC01016FM	6 in. Flow Meter Collar	Used with ERVs and HRVs, at start up, when 6 in. duct work is connected to HRV
KVAAC01017FM	7 in. Flow Meter Collar	Used with ERVs and HRVs, at start up, when 7 in. duct work is connected to HRV
KVAAC01018FM	8 in. Flow Meter Collar	Used with ERVs and HRVs, at start up, when 8 in. duct work is connected to HRV

# PSYCHOMETRIC CHART

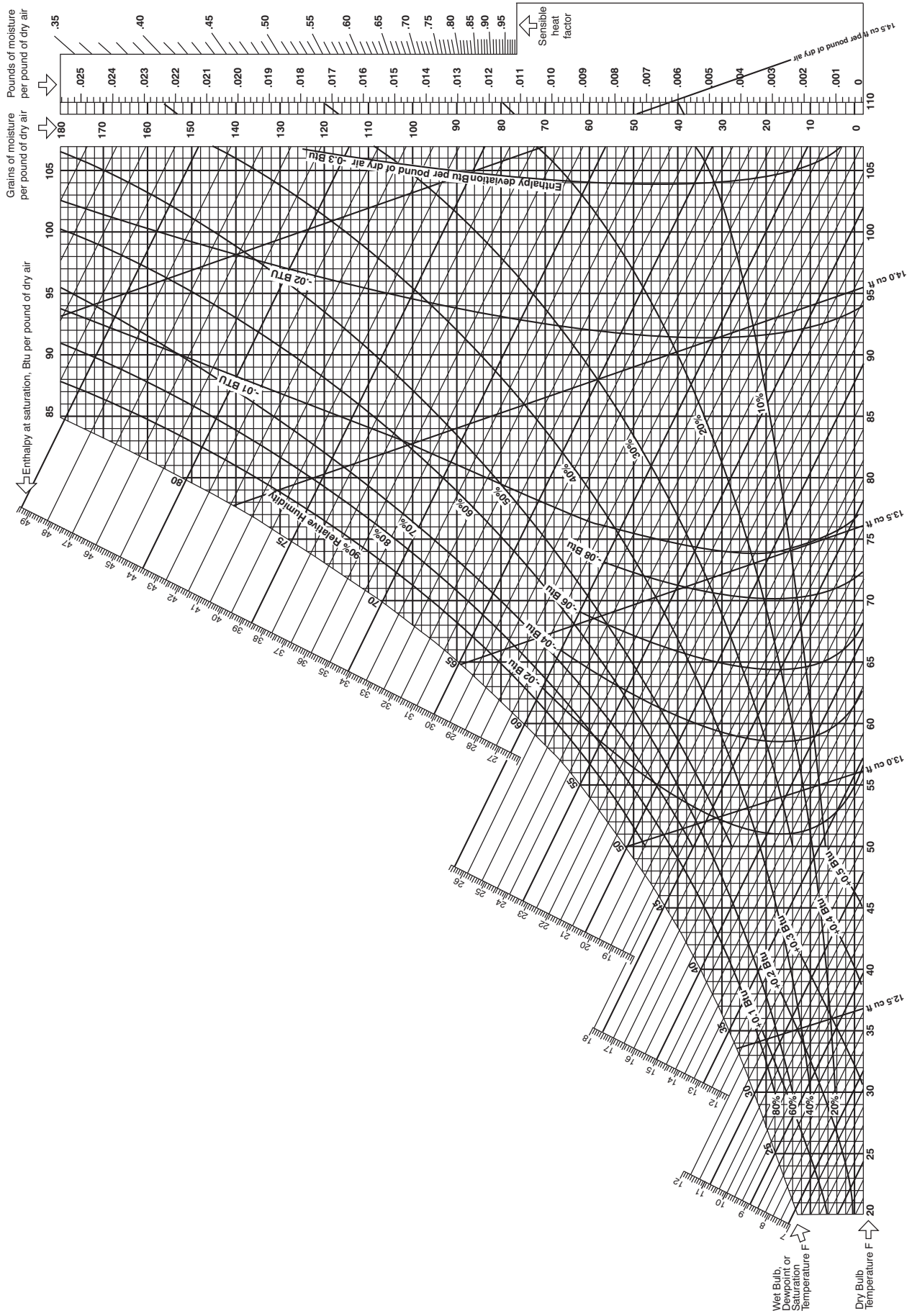

Below 32°F, properties and enthalpy deviation lines are for ice.

