

**ZONEBB(2, 4, 8)KIT01-B
ZONE PERFECT PLUS
ZONING SYSTEM**

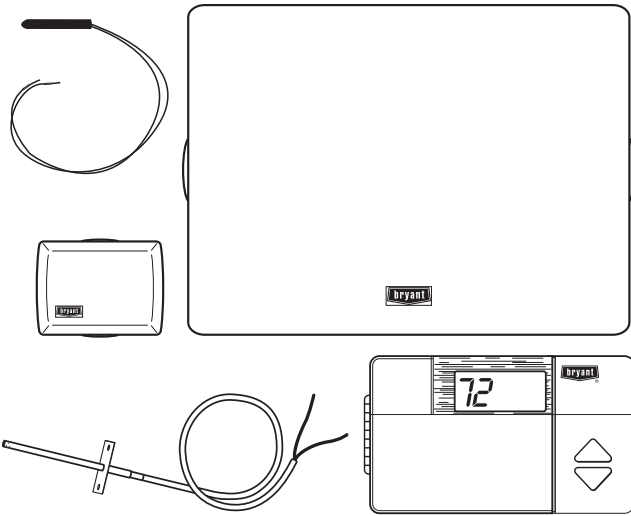

Product Data



2 Zone Kit

A99245

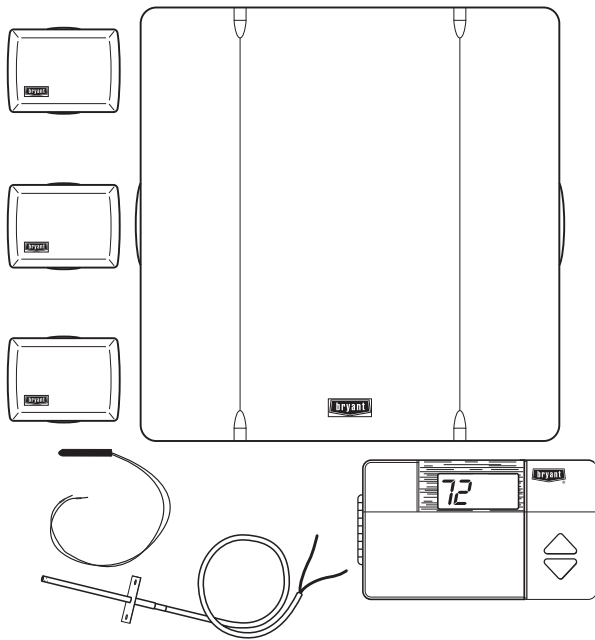

4 Zone Kit

A99246



Zone Perfect Plus is a zoning system capable of providing zone control requirements for 2, 4, or 8 living or business areas. This system allows the home or business owner to control the living environment in an individualized and energy efficient way. The Zone Perfect Plus kit includes the User Interface, Equipment Controller, Remote Sensors, an Outdoor Temperature Sensor, and a Leaving Air Temperature (LAT) Sensor. Zone Perfect Plus is the control center for Perfect Heat/Perfect Humidity.

FEATURES/BENEFITS

The auto changeover User Interface has a backlit display. The home or business owner has the option of programming all zones over a 7-day period by following a few simple, well defined steps. The program allows for period, day, and zone functions to be copied, allowing easier programming.

There are 4 program periods: Wake, Day, Eve, and Sleep. The desired temperature range spans from 40°F to 90°F (4°C to 32°C) and there are separate heating and cooling setpoints. Fully modulating dampers respond to the program as set by the home or business owner and provide worry-free comfort.

Along with a diagnostic error display the User Interface informs the home or business owner when the HVAC system needs to have a filter change. The indoor humidity is also displayed so that indoor comfort can be maximized. The home or business owner can also control indoor humidity depending upon the components in the HVAC system. Optional Smart Sensors allow users to adjust temperature settings from the zone.

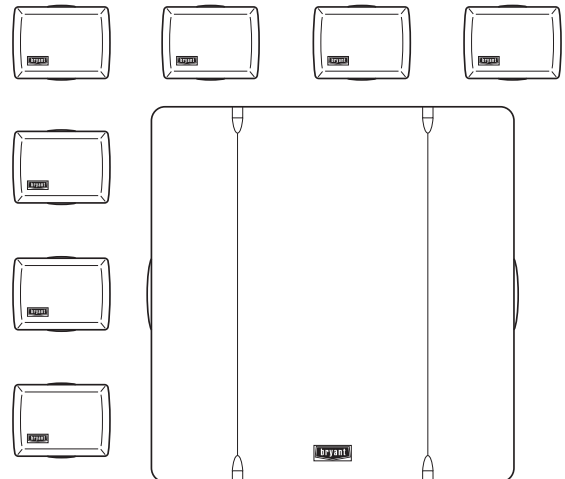

8 Zone Kit

A99247

MODEL NUMBER NOMENCLATURE

1 2 3 4 5 6 7 8 9 10 11 12 13 14
 Z O N E B B 4 K I T 0 1 - B

Product Type
 Zone Product

Series
 -B

Brand
 BB - Bryant

Packaged Quantity
 01

Number of Zones
 0 - Not Zone Dependent
 2 - 2 Zones
 4 - 4 Zones
 8 - 8 Zones

Model Type
 KIT - Zoning Kit
 RRS - Remote Room Sensor
 SMS - Smart Sensor
 USI - User Interface
 EQC - Equipment Controller
 DTS - Duct Temperature Sensor

ZONEKIT

DIMENSIONS

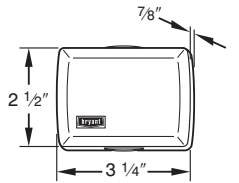

Remote Room Sensor

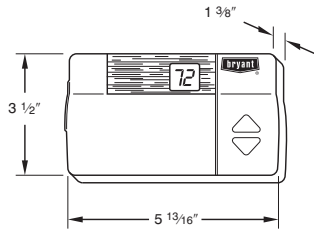

Smart Sensor

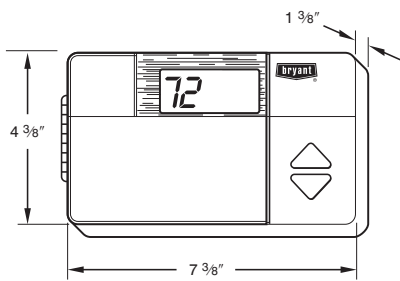

User Interface

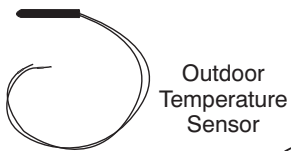

Outdoor Temperature Sensor

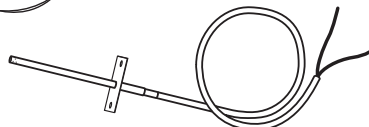

Duct Sensor (LAT Sensor)

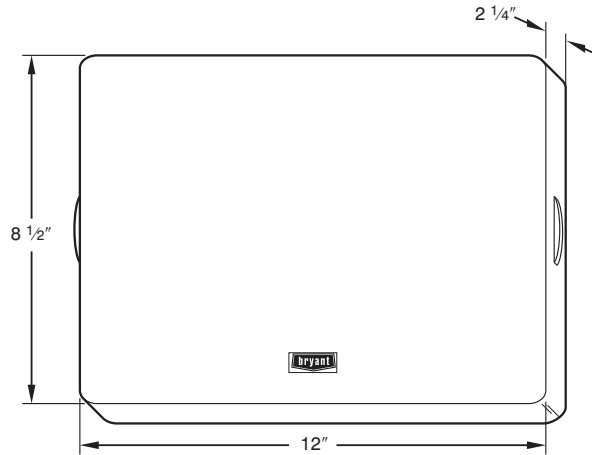

Equipment Controller - 2 Zone

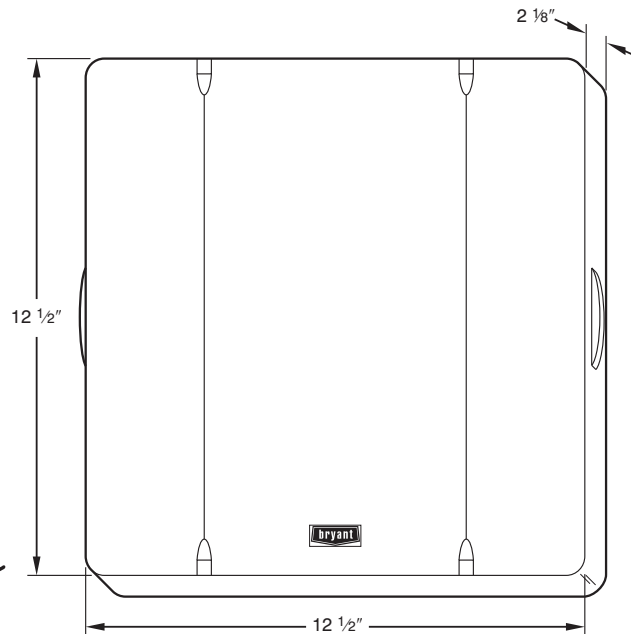

Equipment Controller - 4 and 8 Zone

PRODUCT DATA INFORMATION

Physical Characteristics

Dimensions: See drawing

Appearance: Plastic, eggshell color, textured

Electrical Characteristics

Input Volts/Amps: 24 vac, less than 40VA

Environmental Requirements:

Operating Temperature/Relative Humidity:

User interface, remote sensors, smart sensors: 32°F to 104°F (0°C to 40°C), 95% rh non-condensing

Equipment Controller: 32°F to 158°F (4°C to 70°C), 95% rh non-condensing

Storage Temperature/Relative Humidity:

User interface, remote sensors, smart sensors: -40°F to 134°F (-40°C to 57°C), 95% rh non-condensing

Equipment Controller: -40°F to 185°F (-40°C to 85°C), 95% rh non-condensing

Communication:

Local: RS-485 communication between system components at 9600 baud.

Applications:

Up to 2 stages cool/3 stages heat

Dual fuel (Heat pump with gas furnace backup)

Program Specifications:

Temperature setpoint range: 40°F to 90°F (4°C to 32°C)

Separate heat and cool setpoints

Programming days: 7 day

Programming periods: 4, Wake, Day, Eve, Sleep

Auto changeover (may be disabled)

Programmable fan (Installer selectable)

Humidity Sensor Offsets

Auto Changeover Timer (installer adjustable)

Smart Recovery (in heating and cooling)

Clean filter reminder (installer adjustable)

Hold function

Copy functions: Copy period, day, and zone

Permanent memory

Humidity display and control

Temperature sensor offsets (indoor and outdoor)

Wiring Requirements:

Power supply: Dedicated 24 vac, 40 va, 60 hz isolated transformer, field-supplied.

Wiring material: Standard thermostat wire 18 to 24 gauge.

Equipment Controller to User Interface: 4 wires

Equipment Controller to Remote Sensors: 2 wires

Equipment Controller to Smart Sensors: 4 wires

Equipment Controller to Dampers: 3 wires

Equipment Controller to LAT/HPT Sensor: 2 wires

Equipment Controller to Outdoor Temperature Sensor: 2 wires

ZONEKIT

ZONE PERFECT PLUS

DESCRIPTION	PART NO.
Equipment controller, user interface, duct sensor, outdoor temperature sensor, 1 room sensor	ZONEBB2KIT01 – B
Equipment controller, user interface, duct sensor, outdoor temperature sensor, 3 room sensors	ZONEBB4KIT01 – B
Equipment controller, user interface, duct sensor, outdoor temperature sensor, 7 room sensors	ZONEBB8KIT01 – B

OPTIONAL ACCESSORIES

DESCRIPTION	PART NO.
Smart Sensor	ZONEBB0SMS01
LAT/HPT Sensor (An additional sensor is required for heat pump applications)	ZONEEX0DTS01
Multi-Damper Enabler*	ZONEMLTDMPEN

* Must be used with earlier style dampers (Series A, B, or C), or if more than 3 dampers are used in a single zone.

REPLACEMENT ACCESSORIES

DESCRIPTION	PART NO.
Remote Room Sensor	ZONEBB0RRS01
Equipment Controller — 2 Zone	ZONEBB2EQC01
Equipment Controller — 4 Zone	ZONEBB4EQC01
Equipment Controller — 8 Zone	ZONEBB8EQC01
User Interface	ZONEBB0USI01 – B
Outdoor Temperature Sensor*	TSTATXXSEN01 – B

* Must be used in dual fuel applications, or if automatically adjusting the humidity setpoints in humidification applications.

ACCESSORIES

DAMPERS

ZONEKIT

DESCRIPTION	PART NO.	
Round Dampers	6 in.	DAMPRND06INC
	8 in.	DAMPRND08INC
	10 in.	DAMPRND10INC
	12 in.	DAMPRND12INC
	14 in.	DAMPRND14INC
	16 in.	DAMPRND16INC
Rectangular Dampers	8 in. X 10 in.	DAMPREC08X10
	8 in. X 14 in.	DAMPREC08X14
	8 in. X 18 in.	DAMPREC08X18
	8 in. X 24 in.	DAMPREC08X24
	10 in. X 10 in.	DAMPREC10X10
	10 in. X 14 in.	DAMPREC10X14
	10 in. X 18 in.	DAMPREC10X18
10 in. X 24 in.	DAMPREC10X24	
Round Barometric Bypass	8 in.	DAMPBAR08INC
	10 in.	DAMPBAR10INC
	12 in.	DAMPBAR12INC
	14 in.	DAMPBAR14INC
	16 in.	DAMPBAR16INC
Rectangular Barometric Bypass	8 in. X 14 in.	DAMPBAR08X14
	8 in. X 24 in.	DAMPBAR08X24
Slip-In Dampers	Side mount, 8 X 10	DAMPSLB08X10
	Bottom mount, 8 X 10	DAMPSLB08X10
	Side mount, 8 X 12	DAMPSLB08X12
	Bottom mount, 8 X 12	DAMPSLB08X12
	Side mount, 8 X 14	DAMPSLB08X14
	Bottom mount, 8 X 14	DAMPSLB08X14
	Side mount, 8 X 16	DAMPSLB08X16
	Bottom mount, 8 X 16	DAMPSLB08X16
	Side mount, 8 X 18	DAMPSLB08X18
	Bottom mount, 8 X 18	DAMPSLB08X18
	Bottom mount, 8 X 20	DAMPSLB08X20
	Bottom mount, 8 X 22	DAMPSLB08X22
	Bottom mount, 8 X 24	DAMPSLB08X24
	Side mount, 10 X 10	DAMPSLB10X10
	Bottom mount, 10 X 10	DAMPSLB10X10
	Side mount, 10 X 12	DAMPSLB10X12
	Bottom mount, 10 X 12	DAMPSLB10X12
	Side mount, 10 X 14	DAMPSLB10X14
	Bottom mount, 10 X 14	DAMPSLB10X14
	Side mount, 10 X 16	DAMPSLB10X16
	Bottom mount, 10 X 16	DAMPSLB10X16
	Side mount, 10 X 18	DAMPSLB10X18
	Bottom mount, 10 X 18	DAMPSLB10X18
Bottom mount, 10 X 20	DAMPSLB10X20	
Bottom mount, 10 X 22	DAMPSLB10X22	
Bottom mount, 10 X 24	DAMPSLB10X24	
Bottom mount, 14 X 20	DAMPSLB14X20	
Replacement Actuators	90° for rectangular dampers	DAMPACT90DEG
	45° for round dampers	DAMPACT45DEG

NOTE: The above dampers are recommended because they use the latest style actuators designed for zoning systems. These actuators are direct-drive and use slightly less power to operate. If using older style dampers with this zoning system (ie., dampers with a crank arm), it is recommended to upgrade the actuator to DAMPACT45DEG, or DAMPACT90DEG.