

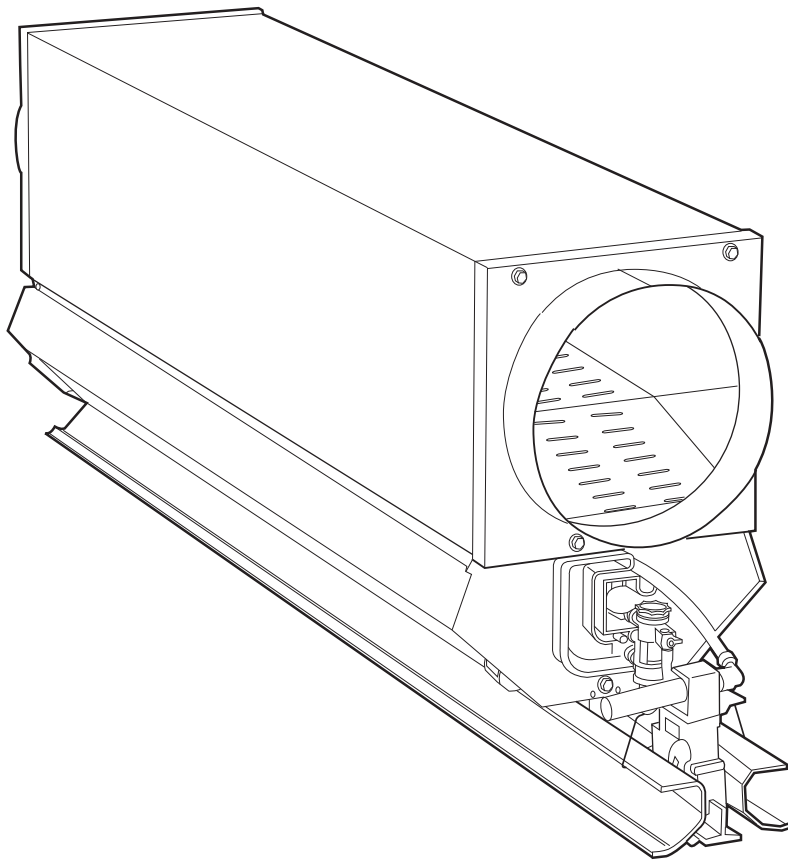

# Product Data

# 37HS Moduline® Air Terminals

Nominal 100 to 400 Cfm



## Features/Benefits

Thirty years ago, Carrier's introduction of the first modular integral diffuser terminals created a unique system for variable air volume distribution and temperature control in the occupied space. Moduline terminals cut installation and alteration costs for cooling distribution with units that could easily be installed, moved to a new location and converted to master control equipment. Today, Carrier's 37HS Moduline terminals prove that years of design and installation experience have resulted in an improved product with even greater adaptability.

- Heating and cooling distribution from the same terminal with automatic changeover and control
- A full range of system (duct pressure) powered controls which offer both volume and temperature control without separate energy control supply
- Integral linear slot diffusers with one-way and 2-way direction, multiple slots, and heating/cooling options
- Single, quiet air valve produces sound levels compatible with private office and conference areas — sound levels decrease with valve throttling
- Accurate volume control with adjustable cfm settings and choice of diffuser or wall-mounted temperature control
- Accessory control devices can interlock Moduline terminals with other energy building systems as well as centralized computer control
- A large range of plenum sizes enables the placement of multiple units in air series
- Optional custom diffusers with variable length, notching and ceiling grid matching for smooth integration with many ceiling designs

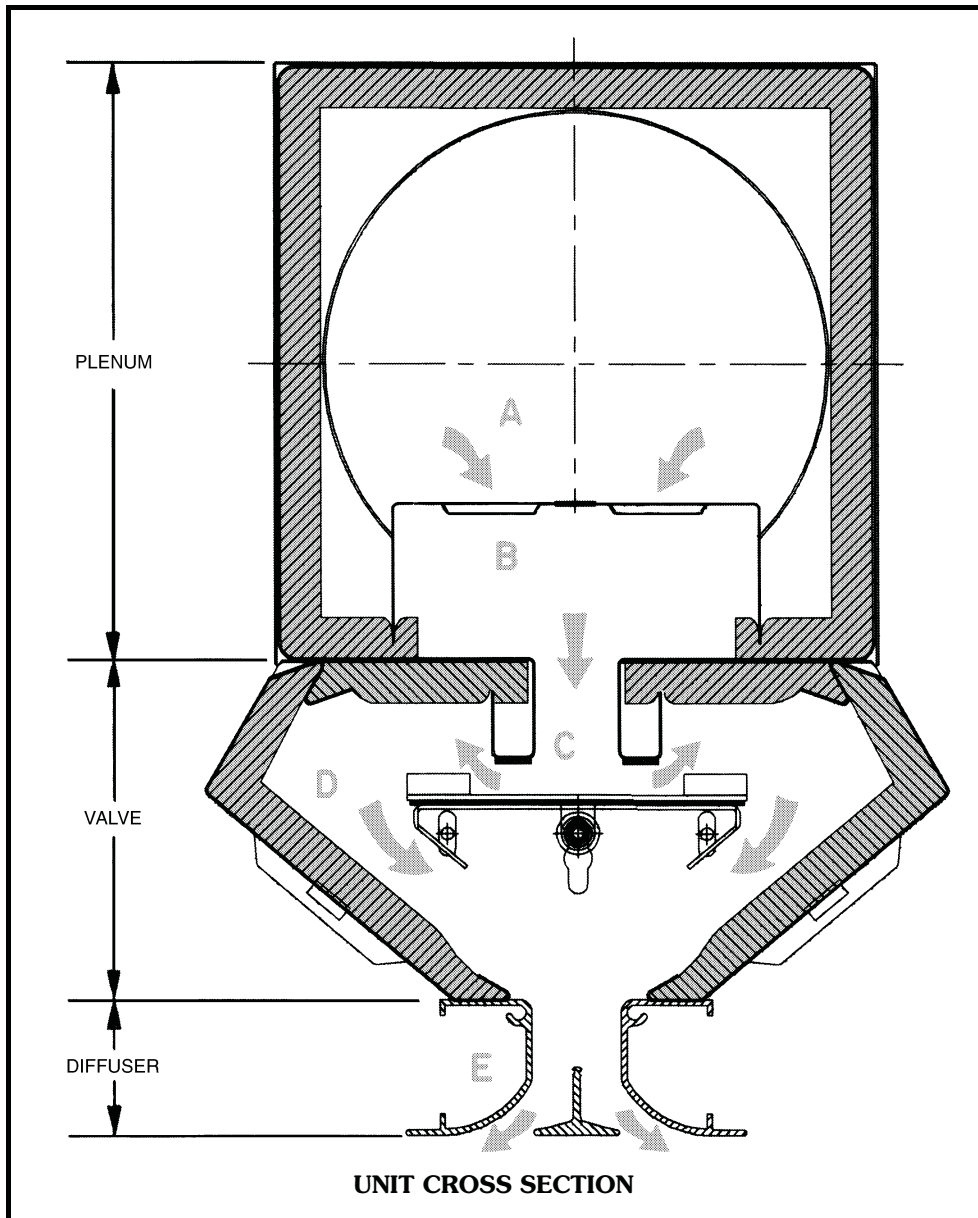

Conditioned primary air obtained from building central station air handling unit or packaged equipment flows from plenum A through the distribution baffle B, providing a relatively even level of air which then flows through valve C to the attenuation space D. The air is distributed to the occupied space through diffuser assembly E.

The Moduline integral diffuser air terminal combines a plenum, valve section, and diffuser in one complete unit. Essential components are:

- Acoustically lined plenum
- Distribution baffle
- Cut-offs
- Bellows
- Sealing pad
- Retainer
- Attenuation/access space
- Extruded aluminum diffusers

# The Moduline control

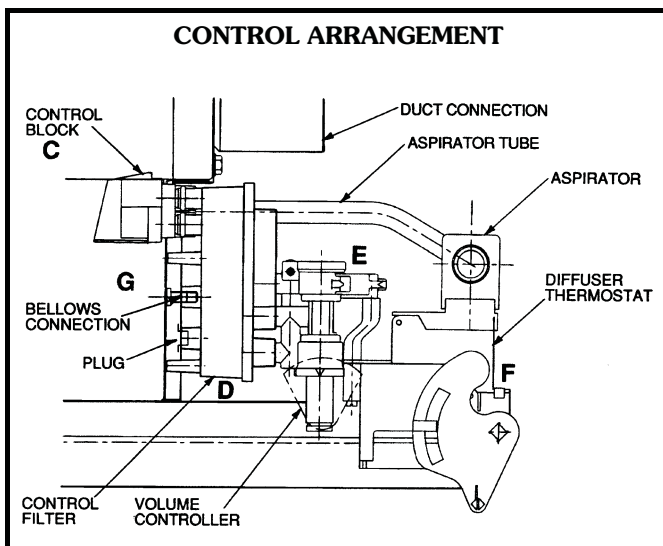
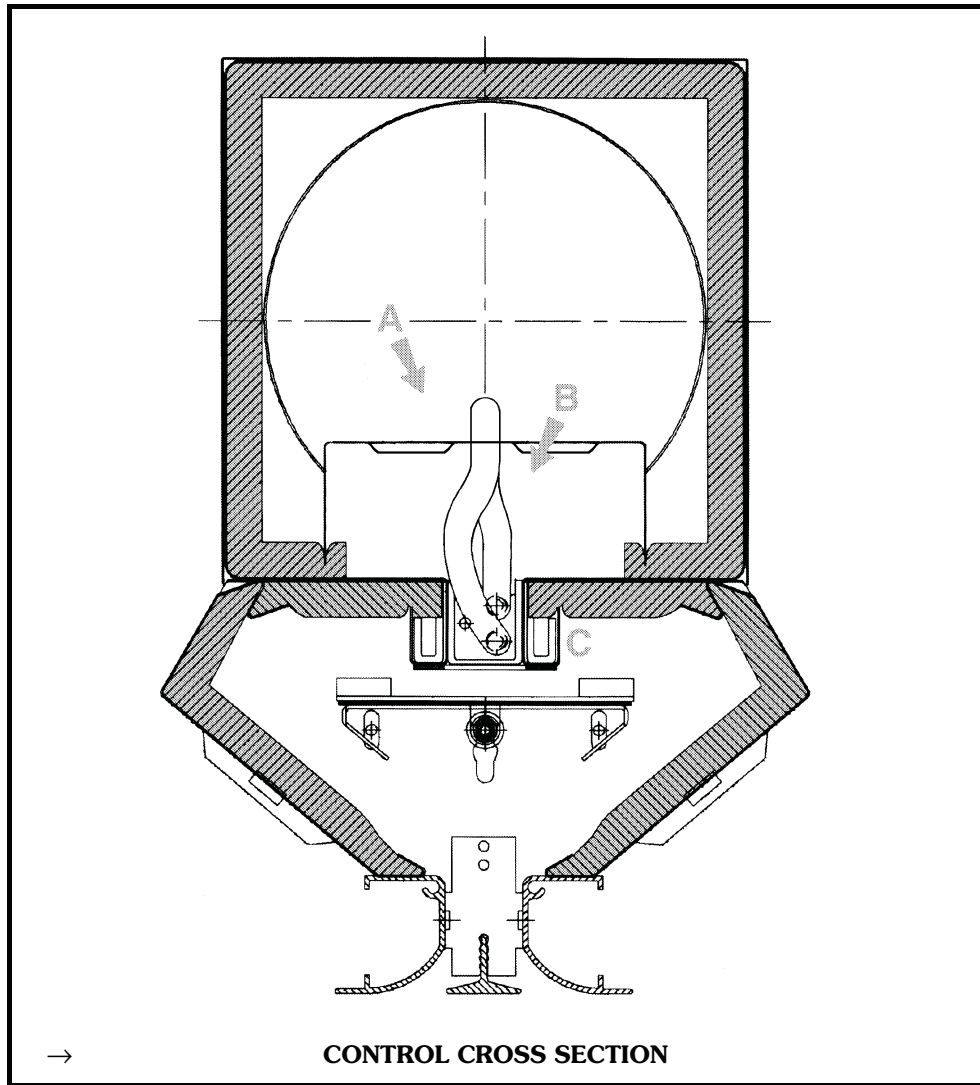

In the Moduline terminal, system-powered control duct pressure obtained at A and distribution pressure at B are brought by tubing to a control block at C, and then through the control air filter D. These pressures are compared in the volume controller E, which in turn provides the correct bellows pressure through the filter at G. The thermostat F reacts to the room temperature and overrides the volume controller to maintain space conditions.

# Table of contents



	Page
Features/Benefits .....	1-3
Model Number Nomenclature .....	4
Unit Dimensions .....	5,6
Options .....	7,8
Accessories .....	8
Selection Procedure .....	9
Performance Data .....	10-12
Controls .....	13,14
Guide Specifications .....	14,15

## → Model number nomenclature

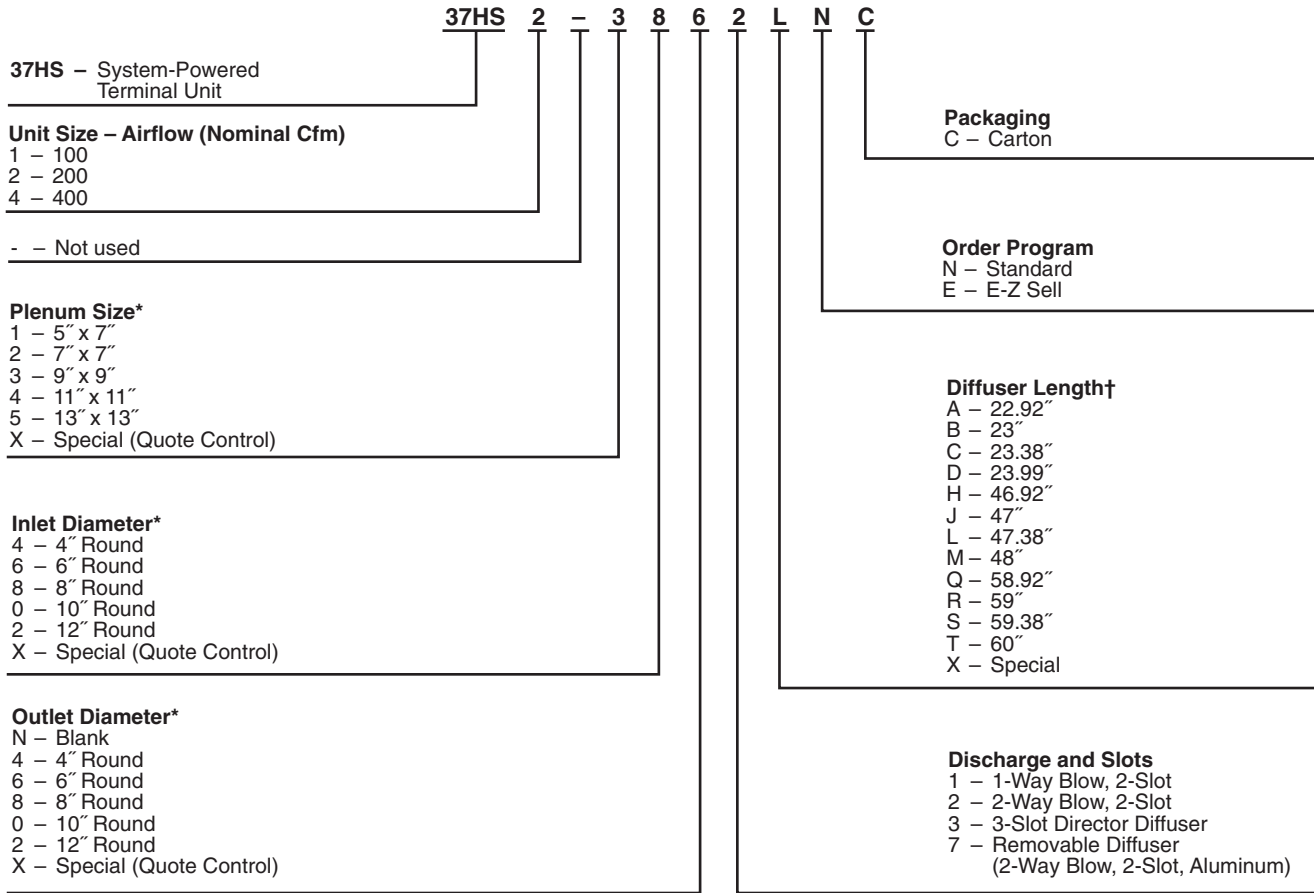

\* AVAILABLE COMBINATIONS OF PLENUM AND COLLAR SIZES

UNIT SIZE 37HS	PLENUM SIZE (in.)	INLET DIAM (in.)	OUTLET DIAM (in.)
<b>1 (100 Cfm)</b>	5 x 7	4	0
	7 x 7	6	4
	7 x 7	6	6
	9 x 9	8	6
	9 x 9	8	8
	11 x 11	10	8
	11 x 11	10	10
<b>2 (200 Cfm)</b>	7 x 7	6	0
	7 x 7	6	6
	9 x 9	8	6
	9 x 9	8	8
	11 x 11	10	8
	11 x 11	10	10
<b>4 (400 Cfm)</b>	9 x 9	8	0
	9 x 9	8	8
	11 x 11	10	8
	11 x 11	10	10
	13 x 13	12	10
	13 x 13	12	12

†See Options, pages 7 and 8, and Unit Dimensions, pages 5 and 6, for available diffuser lengths by unit size.

# Unit dimensions



## 37HS1 (100 Cfm)

NOTE: Dimensions are in inches.

PLENUM SIZE		C	D	E	G	H	J
B <sub>1</sub>	B <sub>2</sub>						
7	5	—	—	4	—	8	20.94
7	7	22.94	4	6	8	9	—
7	7	22.94	6	6	9	9	—
9	9	22.94	6	8	9	10	—
9	9	22.94	8	8	10	10	—
11	11	22.94	8	10	10	11	—
11	11	22.94	10	10	11	11	—

### STANDARD DIFFUSER LENGTHS AVAILABLE (in inches)

A <sub>1</sub>	22.92	23.00	23.38	23.99				
F <sub>1</sub>	2.60	2.60	2.60	2.60				
A <sub>2</sub>					46.92	47.00	47.38	48.00
F <sub>2</sub>					19.56	19.56	19.56	19.56

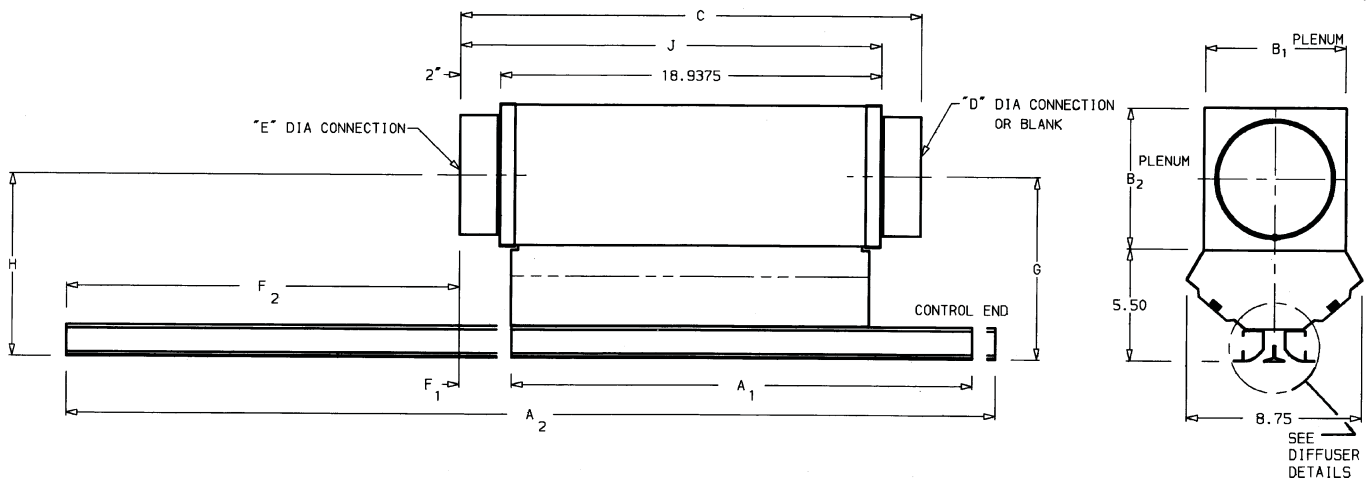

## 37HS2 (200 Cfm)

NOTE: Dimensions are in inches.

PLENUM SIZE (sq.)	C	D	E	G	H	J
B						
7	—	—	6	—	9	39.25
7	41.25	6	6	9	9	—
9	41.25	6	8	9	10	—
9	41.25	8	8	10	10	—
11	41.25	8	10	10	11	—
11	41.25	10	10	11	11	—

### STANDARD DIFFUSER LENGTHS AVAILABLE (in inches)

A	46.92	47.00	47.38	48.00	58.92	59.00	59.38	60.00
F	1.25	1.25	1.25	1.25	7.25	7.25	7.25	7.25

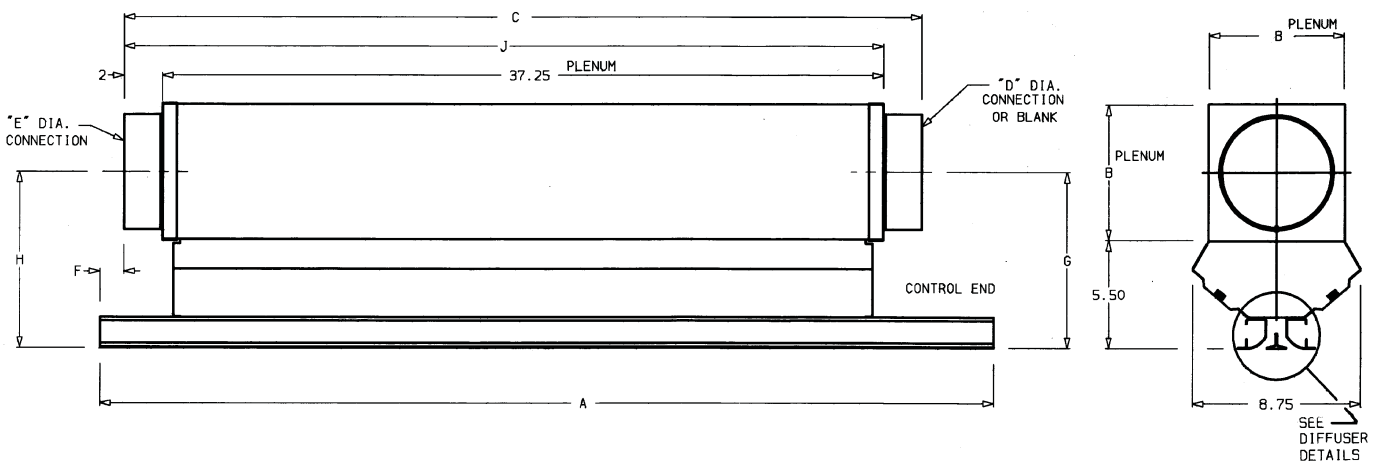

# Unit dimensions (cont)



## 37HS4 (400 Cfm)

NOTE: Dimensions are in inches.

STANDARD DIFFUSER LENGTHS AVAILABLE (in inches)

PLENUM SIZE (sq.) B	C	D	E	G	H	J
9	—	—	8	—	11.50	39.25
9	41.25	8	8	11.50	11.50	—
11	41.25	8	10	11.50	12.50	—
11	41.25	10	10	12.50	12.50	—
13	41.25	10	12	12.50	13.50	—
13	41.25	12	12	13.50	13.50	—

A	46.92	47.00	47.23	47.38	48.00	58.92	59.00	59.38	60.00
F	1.25	1.25	1.25	1.25	7.25	7.25	7.25	7.25	7.25

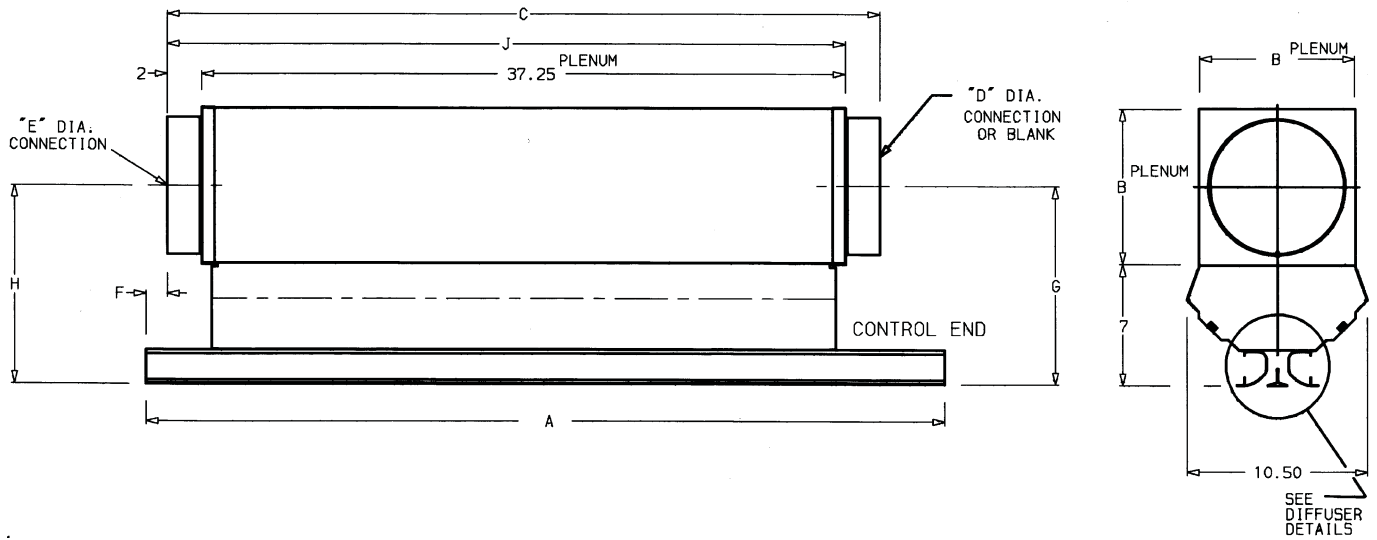

# Options



## Diffuser offerings

Each Moduline® unit can be equipped with one of several diffuser assemblies to suit specific applications.

### → 37HS1, 2

#### EXTRUDED ALUMINUM 2-WAY BLOW

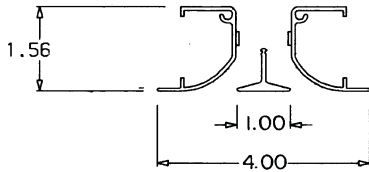

#### EXTRUDED ALUMINUM 1-WAY BLOW

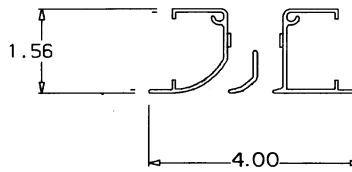

#### EXTRUDED ALUMINUM 3-SLOT

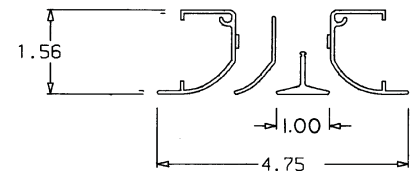

Dimensions are in inches.

#### REMOVABLE DIFFUSER (ALUMINUM)

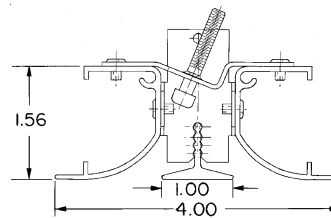

#### 37HS1 (100 Cfm)

CEILING T-BAR STYLE AND WIDTH	DIFFUSER LENGTH (in.)
STANDARD $1\frac{5}{16}$ T-BAR	23.00 47.00
REGULAR $1\frac{5}{16}$ T-BAR	22.92 46.92
CONTINUOUS RUN $1\frac{5}{16}$ T-BAR	24.00 48.00
NARROW $\frac{9}{16}$ T-BAR	23.38 47.38

#### 37HS2 (200 Cfm)

CEILING T-BAR STYLE AND WIDTH	DIFFUSER LENGTH (in.)
STANDARD $1\frac{5}{16}$ T-BAR	47.00 59.00
REGULAR $1\frac{5}{16}$ T-BAR	46.92 58.92
CONTINUOUS RUN $1\frac{5}{16}$ T-BAR	48.00 60.00
NARROW $\frac{9}{16}$ T-BAR	47.38 59.38

# Options (cont)



## Diffuser offerings (cont)

### → 37HS4

**EXTRUDED ALUMINUM  
2-WAY BLOW**

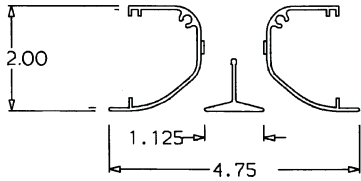

**EXTRUDED ALUMINUM  
1-WAY BLOW**

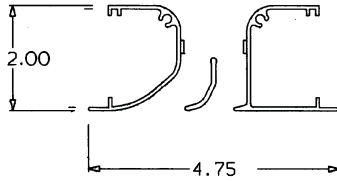

**EXTRUDED ALUMINUM  
3-SLOT**

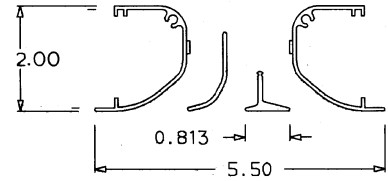

**REMOVABLE DIFFUSER (ALUMINUM)**

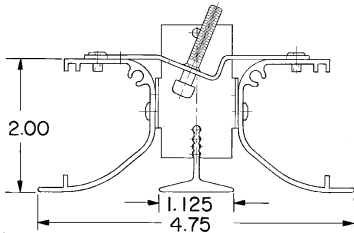

**37HS4 (400 Cfm)**

CEILING T-BAR STYLE AND WIDTH	DIFFUSER LENGTH (in.)
STANDARD $1\frac{5}{16}$ T-BAR	47.00
	59.00
REGULAR $1\frac{5}{16}$ T-BAR	46.92
	58.92
CONTINUOUS RUN $1\frac{5}{16}$ T-BAR	48.00
	60.00
NARROW $\frac{9}{16}$ T-BAR	47.38
	59.38

Dimensions are in inches.

## → Accessories

### Return air diffusers

**EXTRUDED ALUMINUM  
2-WAY BLOW**

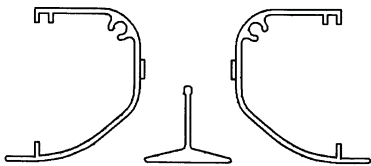

**EXTRUDED ALUMINUM  
1-WAY BLOW**

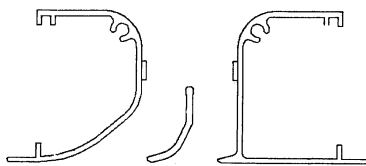

**EXTRUDED ALUMINUM  
3-SLOT**

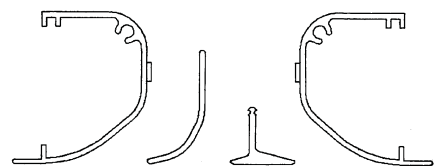

**AVAILABLE LENGTHS (in.)**

37HS1	37HS2	37HS4
23.00	47.00	47.00
47.00	47.38	47.38
	59.00	59.00



# Selection procedure (with example)



## I Determine sensible cooling load (sensible heat gain), supply air temperature and room temperature.

Given:

Application . . . . . Three private offices with west exposure

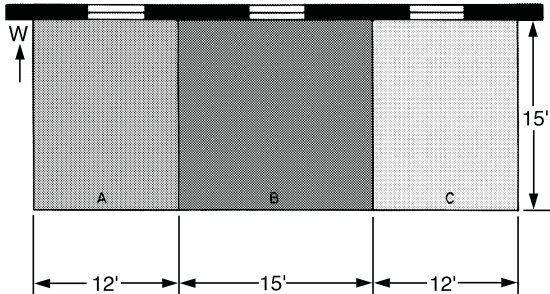

Sensible cooling load:

Offices A and C . . . . .	7713
Btuh Office B . . . . .	9643 Btuh
Supply-air temperature ( $t_{sa}$ ) . . . . .	50 F
Desired room temperature ( $t_{rm}$ ) . . . . .	75 F
Desired room sound level (NC) . . . . .	35
Room effect . . . . .	8 dB
Minimum static pressure . . . . .	0.75 in. wg

## II Determine supply air quantities.

Where:

$$\text{Supply-air quantity (cfm)} = \frac{\text{Sensible cooling load}}{1.09 (t_{rm} - t_{sa})}$$

Offices A and C:

$$\begin{aligned} \text{Supply-air quantity} &= \frac{7713}{1.09 (75 - 50)} \\ &= 283 \text{ cfm} \end{aligned}$$

Office B:

$$\begin{aligned} \text{Supply-air quantity} &= \frac{9643}{1.09 (75 - 50)} \\ &= 354 \text{ cfm} \end{aligned}$$

## III Determine cfm per unit.

From unit model availability, consider 37HS2. Refer to the Sound Selection table and find that at NC 35 and 8 dB room effect, the 37HS2 can provide 200 cfm per unit.

## IV Determine minimum number of units required to obtain proper cfm per unit.

Use the following formula:

$$\text{Minimum number of units} = \frac{\text{Supply-air quantity}}{\text{Recommended cfm/unit}}$$

Offices A and C:

$$\begin{aligned} \text{Minimum number} &= \frac{283}{200} \\ &= 1.41 \text{ (two units)} \end{aligned}$$

Office B:

$$\begin{aligned} \text{Minimum number} &= \frac{354}{200} \\ &= 1.77 \text{ (two units)} \end{aligned}$$

## V Establish the required cfm per unit for units located in the center of the offices:

Use the formula:

$$\text{Cfm per unit} = \frac{\text{Supply-air quantity}}{\text{Minimum number of units}}$$

Offices A and C:

$$\begin{aligned} \text{Cfm} &= \frac{283}{2} \\ &= 141.5 \end{aligned}$$

Office B:

$$\begin{aligned} \text{Cfm} &= \frac{354}{2} \\ &= 177 \end{aligned}$$

The 37HS2 provides 200 cfm per unit, therefore two 37HS2 units can be used.

Again referring to the Sound Selection table, confirm that the 37HS2 unit can provide the required cfm for offices A and C and meet the desired NC level of 35. Enter the table at 8 dB room effect and find by interpolation that at 141.5 cfm and 0.75 in. wg inlet static, the 37HS2 has an approximate NC level of 31.

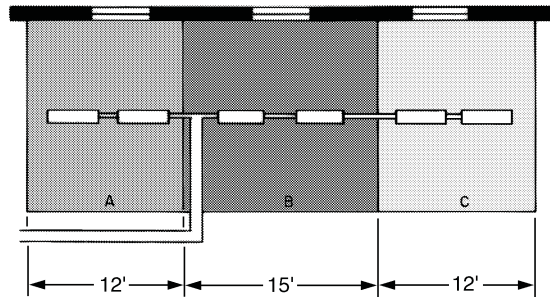

## VI Locate the units in the office space.

Refer to the Optimum Air Throw table and locate units within min/max air throw range.

- Minimum throw — 37HS2 at 141 cfm = 4.0 ft
- Maximum throw — 37HS2 at 141 cfm = 9.0 ft
- Minimum throw — 37HS2 at 177 cfm = 5.0 ft
- Maximum throw — 37HS2 at 177 cfm = 11.5 ft

If units cannot meet range requirements, recalculate the number of units. (Units may also be arranged perpendicular to the office windows.)

## VII Determine minimum duct pressure required.

Refer to Minimum Static Pressure Data.

Minimum duct pressure in the example = 0.75 in. wg.  
NOTE: Be sure to include flex duct pressure loss in determining required duct pressure for Moduline® unit.

## VIII Make final layout.

Coordinate units with lighting fixtures and ceiling construction. Select duct and plenum sizes based on inlet air quantity. Refer to Feed-Through Units table on page 13.

NOTE: If supply air temperature changes, required cfm may also change. An acoustical analysis may therefore be necessary to determine if a higher cfm per unit is permissible. If permissible, fewer units may be required.

# Performance data



## Unit sound selection criteria

Moduline® air terminals actually become quieter as they throttle. This means that the units can be selected at sound levels based on maximum air quantities and minimum duct pressures.

Normally, higher sound levels can be tolerated in perimeter zones with glass in the east, west or south building quadrants, because these areas have cooling demand peaks of relatively short duration (i.e., loads vary widely during the course of the day and year). As a result, slightly higher maximum cfm's are permissible as compared to the interior or north perimeter zones with relatively constant loads.

The maximum air quantity per unit is also affected by the size of the room and the typical distance of the diffuser from the observer, as described in the ASHRAE System Handbook, Chapter 52, and in ARI Application Standard 885-90. Larger rooms, or higher ceilings, will allow higher maximum design air quantities. Room effects may be determined by the architect or may be listed in the plans or specifications.

The following table provides NC (Noise Criteria) levels as a function of a single room effect, as often specified.

### SOUND SELECTION

MODEL	NC LEVELS AT 0.75 in. wg MINIMUM INLET STATIC PRESSURE			
	Unit Cfm	Single Room Effect		
		8 dB	10 dB	12 dB
37HS1	40	<20	<20	<20
	60	20	<20	<20
	80	26	24	22
	100	30	27	25
37HS2	80	26	24	23
	120	29	26	25
	160	32	30	28
	200	35	32	31
37HS4	150	29	27	26
	300	36	34	33
	400	42	40	38

For approximation of NC values for multiple sound sources in the same space, add the correction factor from the following table to the data for a single unit.

DIFFERENCE BETWEEN TWO SOUND VALUES (NC)	CORRECTION FACTOR — AMOUNT TO BE ADDED TO HIGHER VALUE OF SINGLE SOURCES (NC)
0-1	3
2-3	2
4-8	1
9 and Higher	0

For critical applications, contact Carrier for more detailed analysis or consult an acoustician. Unit sound power data and application guides are available under separate cover. Sound power level ratings are based on testing in accordance with ARI 880, industry standard for air terminals. Using specific sound power data, room effect can be calculated in accordance with ARI Standard 885.

Final unit selection is based on the NC Level values recommended by the architect or listed on the plans or specification forms.

Recommendations for NC levels in specific applications can be found in the Carrier Engineering Guide for Sound and Air Conditioned Space and in the ASHRAE Guide and Data Books. Estimated NC levels can be determined through calculation using ARI Standard 885 methods.

## Air throw data

The following air throw data for the Moduline® air terminals provides the suggested minimum and maximum coverages the units can handle in a typical installation while maintaining the desired room conditions.

### 1-WAY AND 2-WAY BLOW, 2-SLOT DIFFUSERS

37HS1 UNIT AIRFLOW (Cfm)	OPTIMUM AIR THROW (ft)			
	1-Way Blow		2-Way Blow	
	Min	Max	Min	Max
40	2.0	7.0	2.0	5.0
50	4.0	9.0	3.0	6.0
60	7.5	12.0	3.5	7.5
70	8.0	15.0	4.0	9.0
80	9.0	18.0	4.5	10.5
90	10.0	20.0	5.0	11.5
100	11.0	22.0	6.0	13.0
110	12.0	24.0	7.0	15.0

37HS2 UNIT AIRFLOW (Cfm)	OPTIMUM AIR THROW (ft)			
	1-Way Blow		2-Way Blow	
	Min	Max	Min	Max
80	2.0	7.0	2.0	5.0
100	4.0	9.0	3.0	6.0
120	7.5	12.0	3.5	7.5
140	8.0	15.0	4.0	9.0
160	9.0	18.0	4.5	10.5
180	10.0	20.0	5.0	11.5
200	11.0	22.0	6.0	13.0
220	12.0	24.0	7.0	15.0

37HS4 UNIT AIRFLOW (Cfm)	OPTIMUM AIR THROW (ft)			
	1-Way Blow		2-Way Blow	
	Min	Max	Min	Max
160	8.5	16.0	5.0	7.0
200	10.0	20.0	6.0	10.0
250	11.0	21.0	7.0	13.0
300	12.0	22.0	8.0	17.0
350	14.0	23.0	9.0	19.0
400	15.0	25.0	10.0	21.0
440	17.0	29.0	13.0	24.0

The optimum air throw values given in the table are distances from the unit centerline to the outside wall or nearest obstruction (wall, light fixture or opposing air stream).

### 2-WAY AND 1-WAY DIRECTOR, 3-SLOT DIFFUSERS

37HS1 UNIT AIRFLOW (Cfm)	OPTIMUM AIR THROW (ft)			
	Heating		Cooling	
	1-Way Blow		2-Way Blow	
	Min	Max	Min	Max
40	2.0	7.0	2.0	5.0
50	4.0	9.0	3.0	6.0
60	7.5	12.0	3.5	7.5
70	8.0	15.0	4.0	9.0
80	9.0	18.0	4.5	10.5
90	10.0	20.0	5.0	11.5
100	11.0	22.0	6.0	13.0
110	12.0	24.0	7.0	15.0

37HS2 UNIT AIRFLOW (Cfm)	OPTIMUM AIR THROW (ft)			
	Heating		Cooling	
	1-Way Blow		2-Way Blow	
	Min	Max	Min	Max
80	2.0	7.0	2.0	5.0
100	4.0	9.0	3.0	6.0
120	7.5	12.0	3.5	7.5
140	8.0	15.0	4.0	9.0
160	9.0	18.0	4.5	10.5
180	10.0	20.0	5.0	11.5
200	11.0	22.0	6.0	13.0
220	12.0	24.0	7.0	15.0

37HS4 UNIT AIRFLOW (Cfm)	OPTIMUM AIR THROW (ft)			
	Heating		Cooling	
	1-Way Blow		2-Way Blow	
	Min	Max	Min	Max
160	8.5	16.0	5.0	7.0
200	10.0	20.0	6.0	10.0
250	11.0	21.0	7.0	13.0
300	12.0	22.0	8.0	17.0
350	14.0	23.0	9.0	19.0
400	15.0	25.0	10.0	21.0
440	17.0	29.0	13.0	24.0

#### NOTES:

1. Minimum air throw refers to the distance from the diffuser where the air velocity is 150 fpm. In maximum air throw, this velocity has dropped to 50 fpm.
2. Data is based on area with 9-ft ceiling. For higher ceilings, values may be reduced by one foot for each foot of height increase. For specific installations, minimum values can be reduced if properly qualified. Values are dependent on cfm only and are not affected by duct pressure.
3. Director 3-slot diffusers used for heating/cooling applications should be located as follows:

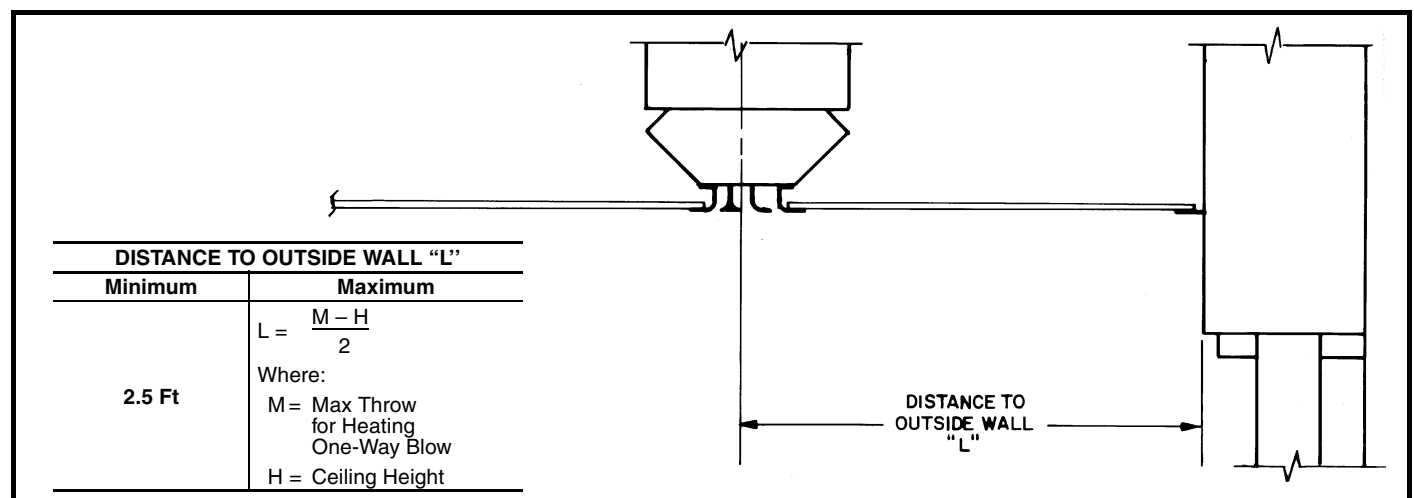

# Performance data (cont)



## MINIMUM STATIC PRESSURE AT CONTROL (MASTER) UNIT — UNITS WITH SYSTEM-POWERED CONTROLS AND STANDARD DIFFUSERS

AIRFLOW (Cfm)	37HS1		37HS2	37HS4
	PLENUM SIZE (in.)			
	5 x 7	7 x 7 9 x 9 11 x 11	7 x 7 9 x 9 11 x 11	9 x 9 11 x 11 13 x 13
Minimum Static Pressure (in. wg)				
40	0.75	0.75	N/A	N/A
50				
60				
70				
80	0.75	0.75	0.75	N/A
90				
100				
110	0.90	0.90	0.75	N/A
120	N/A	N/A	0.75	N/A
140				
160	N/A	N/A	0.75	0.75
180				
200				
220	N/A	N/A	0.90	0.75
240	N/A	N/A	N/A	0.75
280				
320				
360				
400				
440	N/A	N/A	N/A	0.90

### LEGEND

N/A — Not Applicable

NOTE: Maximum inlet pressure — 3.0 in. wg.

MINIMUM AIRFLOW (cfm)		
37HS1	37HS2	37HS4
40	80	160

## FEED-THROUGH UNITS

MODEL	MAXIMUM INLET AIRFLOW		
	Plenum Size (in.)	Duct Size (in.)	Max Inlet Flow (cfm)
37HS1	5 x 7	4	110
	7 x 7	6	400
	9 x 9	8	800
	11 x 11	10	1100
37HS2	7 x 7	6	400
	9 x 9	8	800
	11 x 11	10	1100
37HS4	9 x 9	8	800
	11 x 11	10	1100
	13 x 13	12	1600

NOTE: For all multiple arrangements using 6 in. or less of flexible duct between each unit, add 0.1 in. wg for feed-through static pressure loss. If flexible duct lengths are more than 6 in., add the pressure loss for the extra length as given in the manufacturer's catalog.

→

## MAXIMUM NUMBER OF UNITS IN AN AIR SERIES ON ONE CONTROL

MODEL	PLENUM SIZE (in.) ALL UNITS IN AIR SERIES	NUMBER OF UNITS ON ONE CONTROL			
		2	3	4	5
37HS1	5 x 7*	—	—	—	—
	7 x 7	X	X	X	—
	9 x 9	X	X	X	X
	11 x 11	X	X	X	X
37HS2	7 x 7	X	—	—	—
	9 x 9	X	X	X	—
	11 x 11	X	X	X	—
37HS4	9 x 9	X	—	—	—
	11 x 11	X	X	—	—
	13 x 13	X	X	X	—

\*Unit is available with blank end only; multiple units of this size would not be used on one control.

## RETURN AIR DIFFUSERS

2-SLOT RETURN AIRFLOW (Cfm) 2-WAY AND 1-WAY BLOW					
DIFFUSER PRESSURE DROP (in. wg)	100, 200 SHAPE			400 SHAPE	
	Length (in.)			Length (in.)	
	23.00	47.00, 47.38	59.00	47.00, 47.38	59.00
.01	40	80	100	135	165
.02	55	115	140	190	235
.03	70	140	175	235	290
.04	80	160	200	265	330
.05	90	180	225	300	370
.06	100	200	250	325	410
.07	107	215	270	350	440
.08	115	230	287	375	470
.09	122	245	305	400	500
.10	130	260	315	420	525

3-SLOT RETURN AIRFLOW (Cfm)					
DIFFUSER PRESSURE DROP (in. wg)	100, 200 SHAPE			400 SHAPE	
	Length (in.)			Length (in.)	
	23.00	47.00, 47.38	59.00	47.00, 47.38	59.00
.01	60	120	150	200	245
.02	85	170	210	280	350
.03	105	210	260	345	435
.04	120	240	300	395	495
.05	135	270	340	450	555
.06	150	300	375	485	615
.07	160	320	400	525	660
.08	172	345	430	560	710
.09	182	365	455	595	750
.10	195	390	480	625	785

# Controls



Moduline® terminals are designed to use system-powered (or duct pressure powered) controls which operate with the energy (pressure) of the distribution duct system. The integral diffuser terminal with its control elements is therefore self-contained and independent of other energy distribution in the building, such as electric or pneumatic energy. This approach allows the maximum flexibility in locating and moving modular terminals in the ceiling of the conditioned space.

The Moduline unit offers a variety of control arrangements to meet required control functions. Interlock with other building control systems is also available.

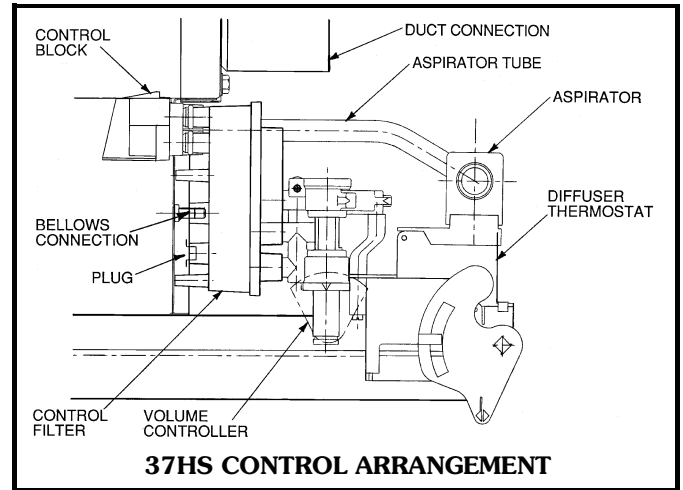

## Control connections

Air from the unit plenum ("high pressure") and downstream of the distribution baffle ("low pressure") is brought by tubing to the unit control block and connected to the control filter through O-ring ports. Bellows pressure is also connected to the filter through a separate port.

Direct connections are then made from the filter to the volume controller for low pressure, bellows pressure, and high pressure.

If a diffuser thermostat is used, the output connection of the volume controller is connected by tubing to the input of the thermostat. The aspirator is connected by tubing to the control block aspirator port.

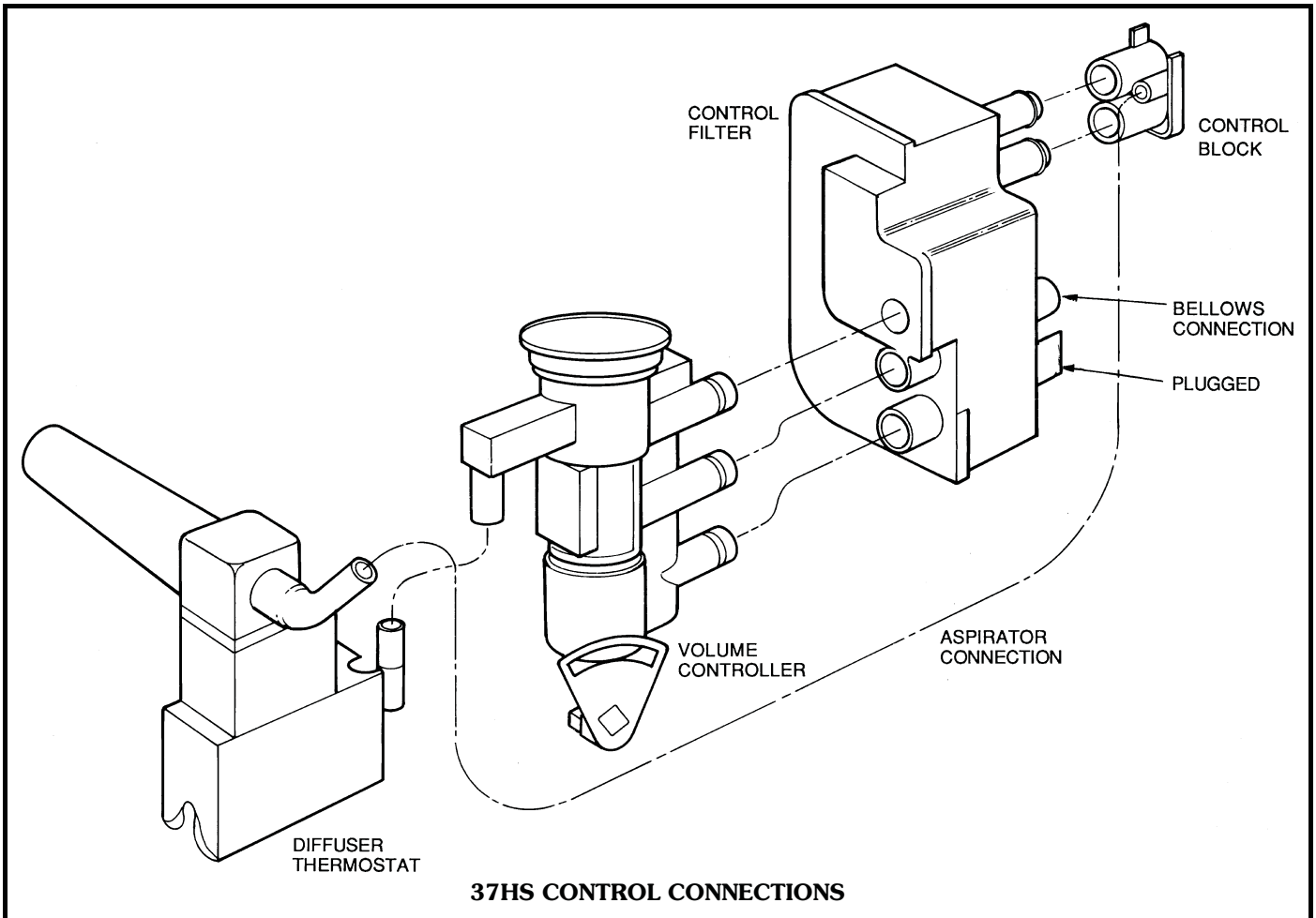

# Controls (cont)



## Operating sequence

A high-pressure signal and a low-pressure signal, measured across the control unit distribution baffle, are transmitted through the unit control block to the control air filter and to the volume controller. The difference between the high and low pressure is an indication of the unit airflow. The control air filter, besides preventing dirt from entering the control system, also acts as a manifold to connect the volume controller to the unit.

The high and low pressure signals act on diaphragms in the volume controller to position a seat relative to a bleed nozzle. The relationship of the seat to the bleed nozzle determines the air pressure transmitted back through the control filter to the unit bellows, which inflates to a position necessary to provide

the airflow preset on the volume controller. A change in input pressures, caused by changes in duct pressure will cause the seat to be repositioned, relative to the bleed nozzle, and change the output pressure to the bellows to maintain the unit airflow. The airflow is preset using the maximum airflow adjusting lever.

The thermostat, wall or diffuser mounted, is connected to the volume controller to provide a means of varying the airflow delivery as room temperature varies from the thermostat setpoint. As room temperature cools to the cooling thermostat setpoint, another bleed orifice, in the thermostat, opens and bleeds control air from the volume controller low side. This causes the volume controller seat to move toward the bleed nozzle, increasing the bellows output pressure, thus closing the unit.

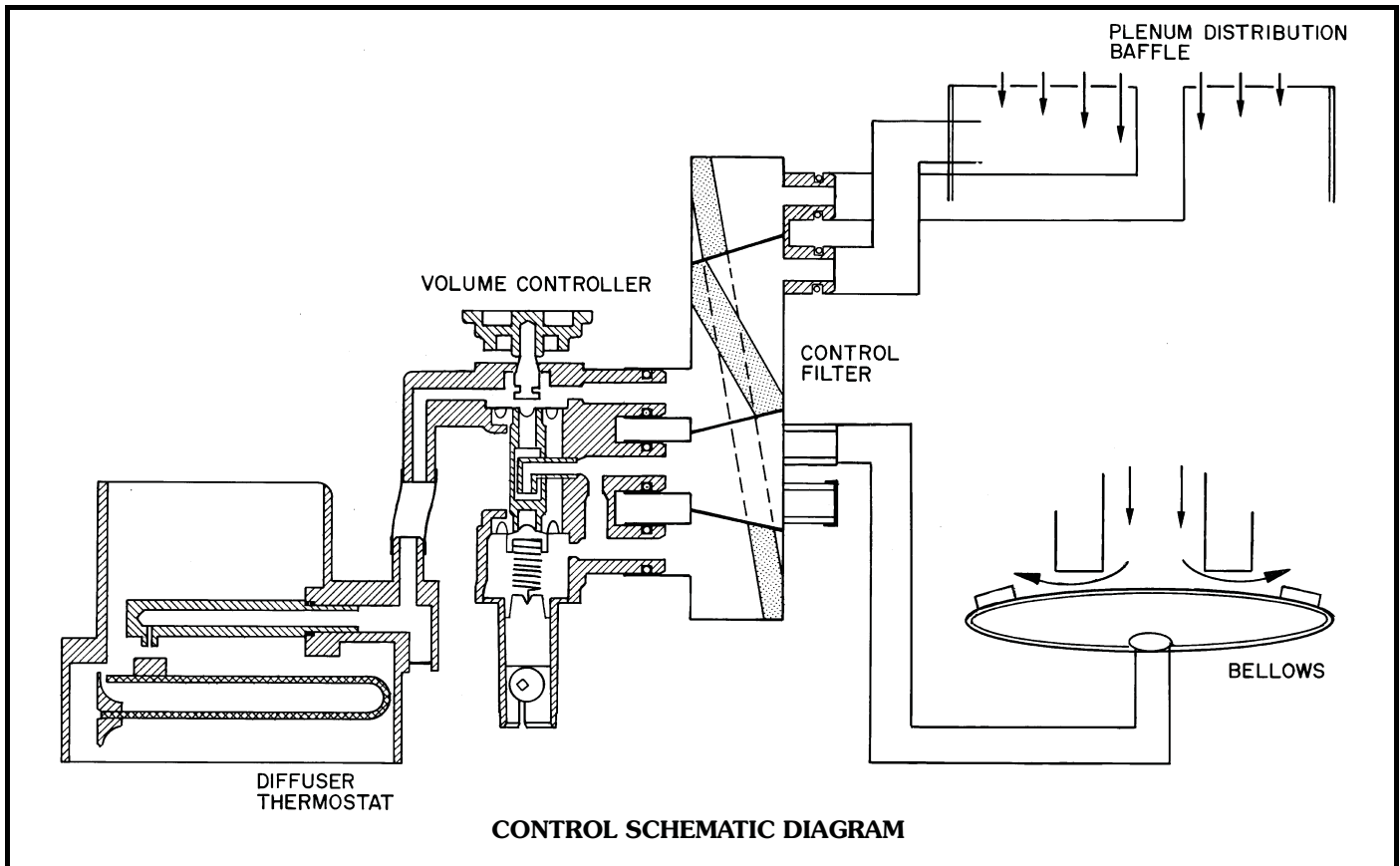

## Guide specifications

### VAV Air Terminal Units

#### HVAC Guide Specifications

Size Ranges: **100 to 400 Cfm**

Carrier Model Numbers: **37HS1  
37HS2  
37HS4**

#### Part 1 — General

##### 1.01 SYSTEM DESCRIPTION

Ceiling-mounted, variable air volume, integral diffuser terminal unit. Manufacturer shall supply unit(s) of the design, number, size and performance shown on the contract drawings and schedule.

##### 1.02 QUALITY ASSURANCE

Insulation and adhesive shall meet NFPA-90A requirements for flame spread and smoke generation, and UL 181 requirements for anti-erosion properties. Performance data shall be provided for air distribution testing by unit manufacturer.

##### 1.03 DELIVERY, STORAGE, AND HANDLING

Units shall be stored and handled per unit manufacturer's recommendations and shall be protected from weather at all times.



## Part 2 — Products

### 2.01 EQUIPMENT

#### A. General:

Factory assembled, single piece, variable air volume ceiling terminal unit complete with an air inlet plenum, automatic variable air volume valve assembly, linear slot-type air diffuser and all required special features. Each terminal shall be easily convertible to a control terminal at any time, through the installation of factory-supplied snap-in type modular control components. Manufacturer supplied installation hardware, as shown on drawings and specifications, shall consist of control tubing and fittings, mounting and support accessories, and diffuser and plenum accessories.

#### B. Inlet Air Plenum:

Feed-through type constructed of 24-gage galvanized steel with inlet and outlet collars, 1/2-in. thick, acoustical/thermal insulation for air velocities up to 2000 fpm. Connections with varying size plenums shall not require transitions.

#### C. Valve Assembly:

Valve shall be factory calibrated, with characteristics matching control, suitable for up to 3 in. wg working pressure, and shall be inflatable urethane bellows-type with no sliding or rotating parts and require no lubrication. Slave unit valves shall be connected to appropriate control terminals at job site.

#### D. Air Diffuser:

Constructed of extruded aluminum and painted with a white recoatable baked enamel, shall be high induction ratio type designed for 1 or 2 way discharge, and of a length as shown on contract drawings.

#### E. Operating Characteristics:

1. Diffuser shall operate from 100% to 10% of design airflow without "dumping" of air when room-to-supply air temperature differential is 25 degrees F.
2. Damper assembly shall maintain the specified air quantity through the system static pressure range of 0.75 to 3.0 in. wg.

#### F. Controls:

1. Temperature controls shall be powered by the system pressure in the supply-air duct and shall operate satisfactorily at the specified duct pressures. Controls shall be designed for snap-in installation per equipment schedule, and located on the terminal above the ceiling, or on a wall.
2. One control assembly installed in a controlling unit may be used to simultaneously control several other slave units via interconnecting tubing to attain uniform response from all units. The number of slave units connected to one master is limited by the manufacturer's instructions.
3. Volume controller supplied separately from the base unit shall be capable of being field set for maximum and minimum flow (cfm). The volume controller will maintain the maximum set airflow

quantity independent of variations in system static pressure.

4. Thermostat shall have an operating range of 65 to 85 degrees F with a throttling range of no more than  $\pm 1.5$  degrees F. It shall be diffuser mounted, and adjustable from below the ceiling. A wall thermostat is also available.

#### → G. Special Features:

Certain standard features are not applicable when the features designated by \* are specified. Contact your local Carrier Sales Office for amending specifications.

- \* 1. Special Ceiling Applications: Units shall be factory designed and built to accommodate custom ceiling layouts as shown on architectural drawings. Hardware, special colors, and method of support required shall be included.
- \* 2. Warm-up Controls: Manufacturer supplied, field installed components to allow terminal to be used for morning warm-up.
- \* 3. Controlled Warm-up or Heating/Cooling Unit: Wall mounted heating/cooling thermostat, changeover valve mounted inside unit to sense primary air, and all necessary hardware to permit terminal to be used as warm-up or heating/cooling shall be supplied by Manufacturer.
- \* 4. Heating/Cooling Diffuser: Unit shall be supplied with factory installed heating/cooling 3-slot diffuser, which shall automatically change over from heating to cooling.
- \* 5. Electric Heat Interlock: Manufacturer supplied, field installed differential pressure switch shall prevent operation of electric heating system until cooling terminal has shut off or has reached its minimum airflow condition.
- 6. Return-Air Diffusers: Manufacturer shall supply matching appearance return-air diffusers for field installation as noted on the contract drawings.
- \* 7. Wall-Mounted Thermostats: Manufacturer shall supply wall-mounted thermostats and all necessary hardware for field installation as shown on the contract drawings.
- \* 8. Heating System Interlock: Manufacturer shall supply a pilot valve for field installation in a master terminal, replacing the thermostat. Pilot valve is to be used with field-supplied pneumatic proportional thermostat to sequence heating and cooling operations.
- \* 9. Installation in Non-Accessible Ceilings: Manufacturer shall supply a terminal unit which can provide access to controls from below the ceiling to allow for replacement and/or adjustment.
- \*10. Removable Diffuser: Manufacturer shall supply a terminal unit with removable diffuser for access to controls in a non-accessible ceiling.



Manufacturer reserves the right to discontinue, or change at any time, specifications or designs without notice and without incurring obligations.