



Product Data

OMNIZONE™ 09XC06-24 Air-Cooled Condensers

5 to 20 Nominal Tons



OMNIZONE™

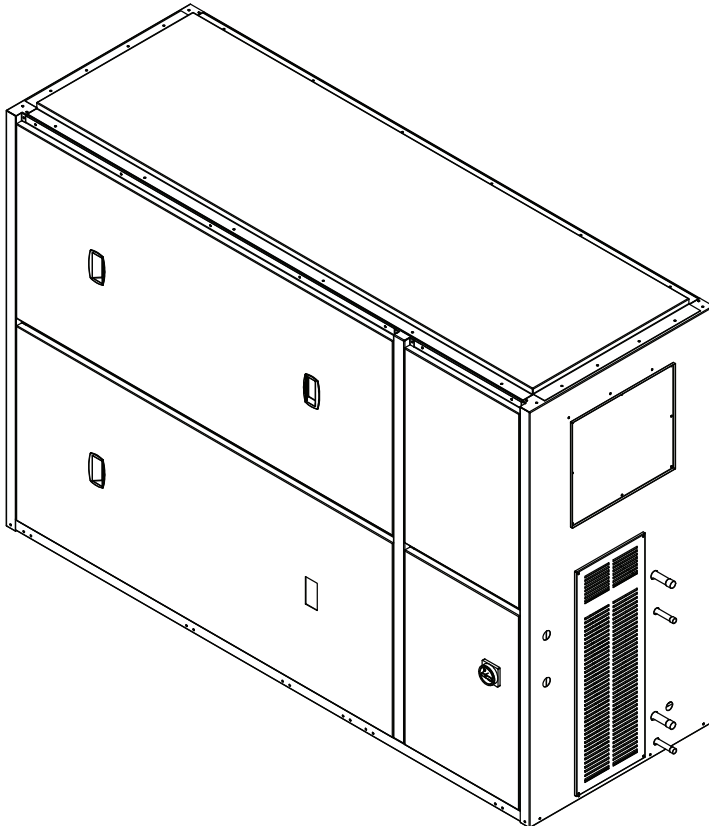

The 09XC air-cooled condenser units for remote applications offer:

- 6 convenient sizes
- optimum performance in all types of building applications
- high static, efficient belt drive condenser fans
- small footprint allows for installation in tight spaces indoors
- units may be ducted or free blow for greater application flexibility

Features/Benefits

The Omnizone 09XC air-cooled condenser units provide a practical and economical approach to comfort conditioning requirements for offices, factories, and other applications.

Design flexibility

The Carrier's 09XC units are remote air-cooled condensers with centrifugal condenser fans for high static condenser airflow applications. These units are available in nominal heat rejection capacities of 5, 7 1/2, 10, 12, 15, and 20 tons. Units are designed for vertical installation with horizontal airflow. Inlet and discharge are on the same face of the unit. Units can only be mounted indoors. Belt drive centrifugal condenser fan provides high-static capability for air inlet and discharge through louvers and extended duct runs.

Features/Benefits (cont)



Economic operation

Integral subcooling circuit offers greater cooling capacity. This specially designed liquid refrigerant circuit provides subcooling for increased capacity without additional power consumption. Subcooling liquid refrigerant also expands condenser applications by permitting installation below the evaporator, without subjecting the refrigerant to flashing before the expansion valve.

Three-phase motors with inherently better starting torque and efficiency make the units even more economical to operate.

Application flexibility

The unit can be placed where no other option would work because of high-static capability. Unit may be mounted indoors with duct runs, or mounted at the wall with a louver. Mount the unit at a distance from an outside wall and duct the condenser air; due to the high static belt drive motor, static pressure losses as high as 1 in. wg may be overcome.

High quality paint process allows the unit to meet 500-hour salt spray requirements for a weather resistant cabinet that will hold up year after year.

Two circuits are provided on units 10 tons and above.

Unit should be matched with a Carrier 50XCR unit in order to meet a wide range of application requirements.

Installation flexibility

Low voltage 24-v control contactor is provided in the unit control box. This results in cost savings for running control power from the compressor unit to the condenser.

Ease of service

Quick removal access panels on both side of the unit allow for all service through the side of the unit, with easy access to controls and motor.

Belt drive motors slide on motor mounting rails for easy adjustment and replacement.

Permanently lubricated fan and motor bearing provide maximum reliability with minimal routine service.

Dependable and safe operation

Total enclosed fan motors with built in overload protection mean dependable and safe operation even in an environment where the fans are exposed to heavy rain.

Units are listed by UL (Underwriters Laboratories) for safe operation and are UL listed for U.S.A. and Canada.

Unit quality is assured day to day as the units are built in a factory with ISO 9001 certification.

Special features for outstanding performance

- Space saver slab type condenser coils use Carrier's advanced heat transfer technology and provide peak heat transfer efficiency with large coil face area. Fins are mechanically bonded to nonferrous, seamless tubing for efficient leakfree operation.

- Large volumes of outdoor air are moved quietly. Specially designed fan section provides superior air-handling capability at high efficiency and low sound.
- Convenient access electrical control center contains all factory pre-wired control devices.
- The weatherproof cabinets are constructed of galvanized steel and painted with Powercoat Paint System, capable of withstanding Federal Test Method Standard No. 141 (Method 6061) 500-Hour Salt Spray Test.
- The 09XC units all carry a standard limited one-year warranty on all parts.
- All motors are protected against thermal overload, and three-phase motors are protected against single-phasing conditions.
- Units are built in an ISO 9001 (International Standards Organization) certified manufacturing facility, and are fully factory run-tested.

Table of contents

| | Page |
|-------------------------------------|-------|
| Features/Benefits | 1,2 |
| Model Number Nomenclature | 3 |
| AHRI Capacity Ratings | 3 |
| Physical Data | 4 |
| Options and Accessories | 4 |
| Dimensions | 5,6 |
| Selection Procedure | 6 |
| Performance Data | 7-18 |
| Electrical Data | 19 |
| Typical Wiring Schematic | 20-22 |
| Controls | 23 |
| Typical Piping and Wiring | 24 |
| Application Data | 25-27 |
| Guide Specifications | 28 |

Model number nomenclature



09XC 24 A H 5 A 0 AA

09XC – OMNIZONE™ Remote Air-Cooled Condenser

Unit Size – Nominal Tons

06 – 5 **14** – 12
08 – 7 1/2 **16** – 15
12 – 10 **24** – 20

Condenser Coil Options

- A** – No Condenser Filter, No Low Ambient Option, Low ESP
- B** – No Condenser Filter, No Low Ambient Option, Medium ESP
- C** – No Condenser Filter, No Low Ambient Option, High ESP
- D** – No Condenser Filter, No Low Ambient Option, Highest ESP*
- F** – No Condenser Filter, Low Ambient Option, Low ESP
- G** – No Condenser Filter, Low Ambient Option, Medium ESP
- H** – No Condenser Filter, Low Ambient Option, High ESP
- J** – No Condenser Filter, Low Ambient Option, Highest ESP*

Factory-Installed Options Code

Set by selection program

Design Revision Level

0 – Original Release

Control Options

A – Standard Controls

Voltage Options

- 1** – 575-3-60
- 5** – 208/230-3-60
- 6** – 460-3-60

Condenser Motor Hp Options

- D** – 1 Hp Motor
- E** – 1 1/2 Hp Motor
- F** – 2 Hp Motor
- G** – 3 Hp Motor
- H** – 5 Hp Motor
- J** – 7 1/2 Hp Motor

* Highest ESP not available for size 14-24.

AHRI* capacity ratings

| UNIT 09XC | NOMINAL TONS | CONDENSER CFM | HEAT REJECTION (Btuh) | TOTAL kW |
|--------------|-----------------|------------------|-----------------------------|-------------|
| 06 | 5 | 3,000 | 84,600 | 0.66 |
| 08 | 7 1/2 | 4,500 | 126,800 | 1.10 |
| 12 | 10 | 6,000 | 169,200 | 1.86 |
| 14 | 12 | 6,800 | 211,400 | 2.09 |
| 16 | 15 | 7,500 | 253,600 | 2.19 |
| 24 | 20 | 10,000 | 380,400 | 2.87 |

*AHRI — Air Conditioning, Heating, and Refrigeration Institute.

NOTE: Unit is tested in accordance with AHRI standard 340/360.



Physical data



| UNIT 09XC | 06 | 08 | 12 | 14 | 16 | 24 |
|---|--|-------------|-------------|-------------|-------------|---------------|
| NOMINAL CAPACITY (tons) | 5 | 7.5 | 10 | 12 | 15 | 20 |
| UNIT OPERATING WEIGHT (lb) | 328 | 527 | 732 | 880 | 956 | 1214 |
| CONDENSER FAN | Adjustable, Belt-Drive, Centrifugal | | | | | |
| Nominal Cfm | 2800 | 3500 | 5500 | 8000 | 8000 | 11,400 |
| Cfm Range | 2100 - 3500 | 2625 - 4300 | 4125 - 6875 | 6000 - 9500 | 6000 - 9500 | 8550 - 12,700 |
| Available Static (in. wg) | 0 - 1.0 | 0 - 1.0 | 0 - 1.0 | 0 - 1.0 | 0 - 1.0 | 0 - 1.0 |
| Condenser Fan Size | 110-10R | 110-10R | 150-12R | 150-15R | 150-15R | 150-11R |
| Number of Condenser Fans | 2 | 2 | 2 | 2 | 2 | 3 |
| Standard Speed Range (Rpm) | 656 - 875 | 712 - 949 | 712 - 949 | 764 - 1011 | 764 - 1011 | 820 - 1041 |
| Max. Allowable Rpm | 1700 | 1700 | 1700 | 1600 | 1600 | 1700 |
| Belt (Type) | BX66 | BX65 | BX75 | BX77 | BX82 | BX87 |
| Fan Pulley (Type) | BK70 | BK65 | BK90 | BK100 | BK130 | BK85 |
| Motor Pulley (Type) | 1VP34 | 1VP34 | 1VP34 | 1VP34 | 1VP44 | 1VP50 |
| Std HP | 1 | 1.5 | 2 | 2 | 3 | 5 |
| HP Range | 1 - 1.5 | 1.5 - 2 | 2 - 3 | 2 - 3 | 3 - 5 | 5 - 7.5 |
| Fan Shaft Size (in.) | 1 | 1 | 1 | 1.1875 | 1.1875 | 1.4375 |
| Motor Shaft Size (in.) | 0.875 | 0.875 | 0.875 | 0.875 | 1.125 | 1.125 |
| Center Distance (in.) | 27.1 | 27.1 | 29.8 | 29.8 | 29.8 | 35.1 |
| CONDENSER COIL | ³ / ₈ -in. OD, Enhanced Copper Tube, Aluminum Fins | | | | | |
| Quantity Rows ... Fin/in. | 6...16 | 6...16 | 6...16 | 6...16 | 6...16 | 6...16 |
| Fin Block Size (H x L) (in.) | 30 x 46 | 30 x 46 | 34 x 60 | 34 x 80 | 34 x 80 | 40 x 80 |
| Face Area (sq ft) | 9.6 | 9.6 | 14.2 | 18.9 | 18.9 | 22.2 |
| Refrigerant Gas Inlet Connection Size (in.) | 0.625 | 0.625 | (2) 0.625 | (2) 0.625 | (2) 0.625 | (2) 0.875 |
| Refrigerant Liquid Connection Size (in.) | 0.500 | 0.500 | (2) 0.500 | (2) 0.500 | (2) 0.500 | (2) 0.625 |

Options and accessories

| ITEM | FACTORY-INSTALLED OPTION | FIELD-INSTALLED ACCESSORY |
|-----------------------|--------------------------|---------------------------|
| Hot Water Coil | | X |
| Low Ambient Operation | X | |

Factory-installed options

Low ambient option allows a refrigerant pressure controlled VFD (variable frequency drive) to adjust condenser fan speed to control head pressure. This fan speed control permits unit to operate in cooling even in winter, when outdoor air temperature is down to 0° F.

Field-installed accessories

Hot water coil provides a 2-row coil encased in a 5 in. deep metal casing.

Dimensions — 09XC06-24

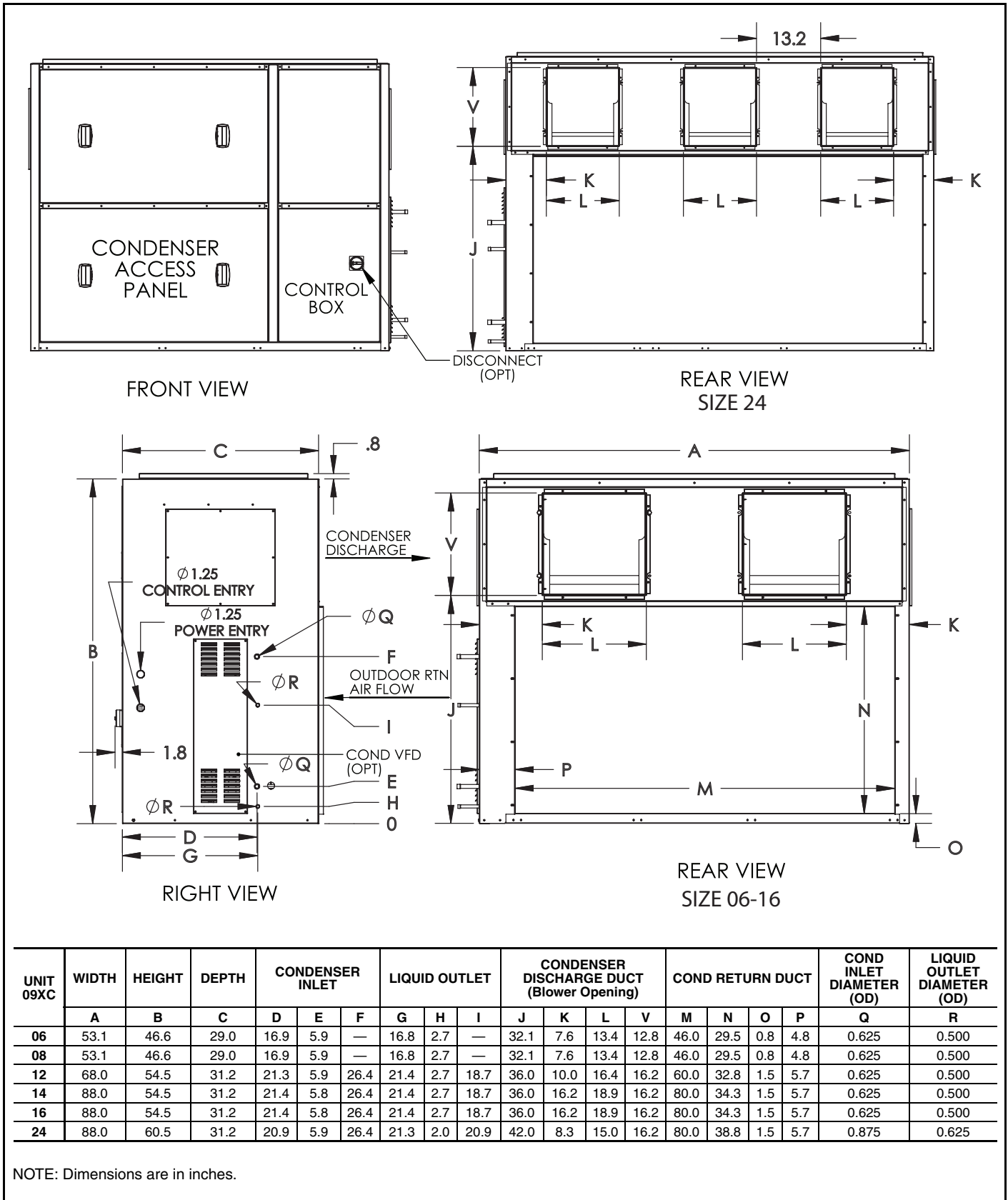

Dimensions (cont)

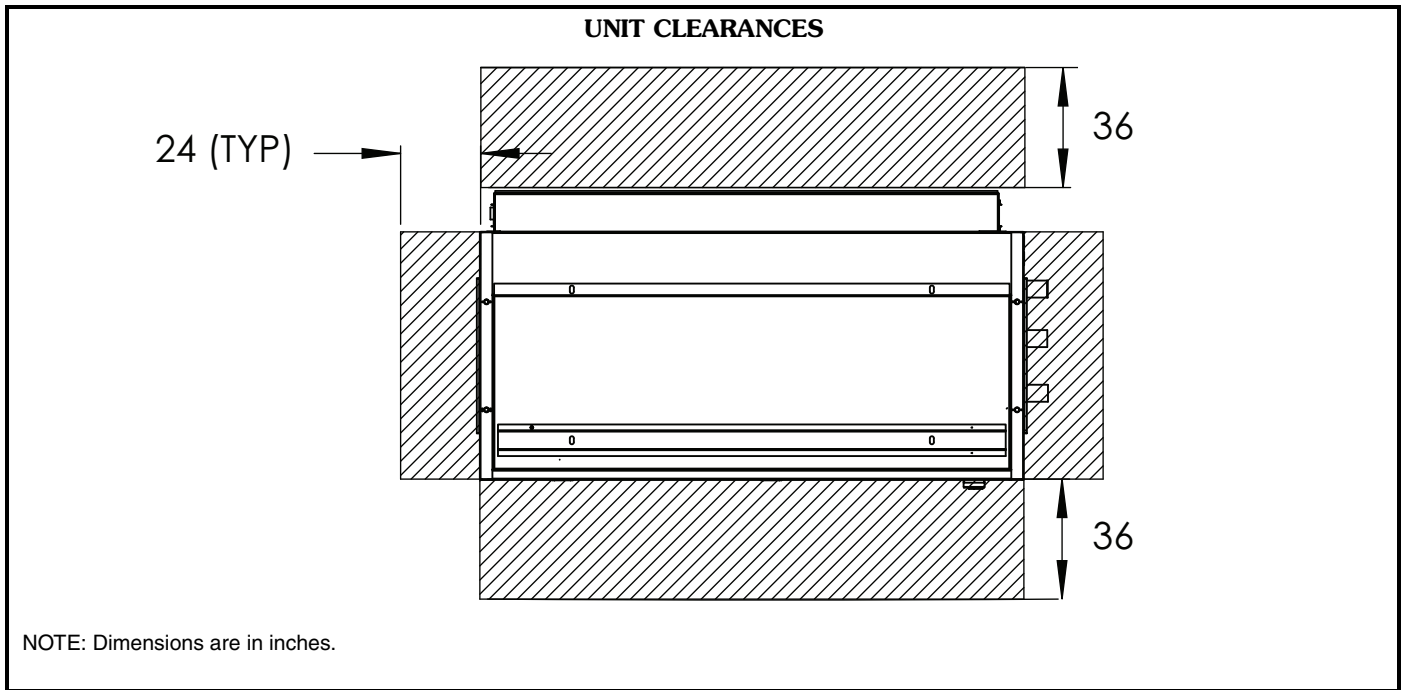

Selection procedure

Use Carrier's performance and selection software to perform unit selections at a variety of actual operating conditions. Performance at typical operating conditions are incorporated in the following performance tables.

Performance data



GROSS COOLING CAPACITIES

50XCR06 (5 TONS) UNIT WITH 09XC06 (5 TONS) UNIT

| Entering Condenser Air | | BF | AIR ENTERING EVAPORATOR — 80 F Edb (F) — CFM | | | | | | | | | | | | |
|------------------------|------|-------|--|-------|-------|-------|-------|-------|-------|-------|-------|-------|-------|-------|------|
| | | | 10000 | | | | 8000 | | | | 6000 | | | | |
| ECT (F) | CFM | | Air Entering Evaporator — Ewb (F) | | | | | | | | | | | | |
| | | 57 | 62 | 67 | 75 | 57 | 62 | 67 | 75 | 57 | 62 | 67 | 75 | | |
| | | 0.20 | 0.10 | 0.10 | 0.03 | 0.34 | 0.15 | 0.14 | 0.10 | 0.44 | 0.22 | 0.18 | 0.15 | | |
| 55 | 2100 | TC | 73.4 | 74.8 | 80.4 | 90.4 | 68.8 | 71.9 | 77.8 | 87.8 | 62.9 | 67.9 | 73.7 | 83.7 | |
| | | SHC | 73.4 | 70.2 | 58.6 | 38.9 | 68.8 | 63.2 | 53.4 | 36.9 | 62.1 | 55.2 | 47.5 | 34.5 | |
| | | LDB | 53.08 | 54.40 | 58.75 | 65.92 | 48.48 | 51.18 | 55.83 | 63.36 | 42.07 | 46.49 | 51.34 | 59.30 | |
| | | LWB | 45.41 | 51.41 | 56.79 | 65.43 | 43.16 | 48.97 | 54.36 | 63.10 | 39.61 | 45.04 | 50.43 | 59.29 | |
| | | | kW | 3.26 | 3.28 | 3.35 | 3.49 | 3.20 | 3.24 | 3.32 | 3.45 | 3.13 | 3.19 | 3.26 | 3.40 |
| | 2800 | TC | 74.0 | 75.7 | 81.5 | 92.2 | 69.3 | 72.7 | 78.8 | 89.4 | 63.3 | 68.5 | 74.5 | 85.0 | |
| | | SHC | 74.0 | 70.7 | 59.0 | 39.5 | 69.3 | 63.6 | 53.7 | 37.4 | 62.4 | 55.4 | 47.8 | 35.0 | |
| | | LDB | 52.85 | 54.22 | 58.60 | 65.71 | 48.23 | 51.03 | 55.66 | 63.11 | 41.87 | 46.35 | 51.15 | 59.01 | |
| | | LWB | 45.30 | 51.28 | 56.63 | 65.22 | 43.03 | 48.84 | 54.18 | 62.86 | 39.46 | 44.88 | 50.23 | 59.00 | |
| | | | kW | 2.86 | 2.87 | 2.90 | 2.99 | 2.83 | 2.85 | 2.89 | 2.97 | 2.79 | 2.82 | 2.86 | 2.94 |
| | 3500 | TC | 74.5 | 76.1 | 82.2 | 93.1 | 69.6 | 73.0 | 79.4 | 90.2 | 63.5 | 68.8 | 75.0 | 85.6 | |
| | | SHC | 74.5 | 70.9 | 59.3 | 39.9 | 69.6 | 63.8 | 54.0 | 37.7 | 62.5 | 55.6 | 48.0 | 35.2 | |
| LDB | | 52.70 | 54.13 | 58.49 | 65.59 | 48.09 | 50.95 | 55.54 | 62.97 | 41.79 | 46.23 | 51.01 | 58.88 | | |
| LWB | | 45.22 | 51.21 | 56.54 | 65.11 | 42.96 | 48.76 | 54.08 | 62.73 | 39.39 | 44.77 | 50.11 | 58.87 | | |
| | | kW | 2.63 | 2.64 | 2.66 | 2.71 | 2.62 | 2.63 | 2.65 | 2.70 | 2.60 | 2.62 | 2.63 | 2.67 | |
| 75 | 2100 | TC | 68.7 | 69.3 | 74.4 | 83.5 | 64.6 | 66.7 | 72.1 | 81.3 | 59.0 | 63.2 | 68.6 | 77.8 | |
| | | SHC | 68.7 | 67.3 | 56.1 | 36.5 | 64.6 | 60.6 | 50.9 | 34.5 | 59.0 | 52.8 | 45.1 | 32.2 | |
| | | LDB | 54.80 | 55.46 | 59.67 | 66.79 | 50.37 | 52.37 | 56.96 | 64.42 | 43.96 | 47.94 | 52.76 | 60.63 | |
| | | LWB | 46.22 | 52.26 | 57.64 | 66.23 | 44.09 | 50.05 | 55.40 | 64.09 | 40.86 | 46.40 | 51.77 | 60.58 | |
| | | | kW | 4.29 | 4.30 | 4.38 | 4.53 | 4.23 | 4.26 | 4.35 | 4.49 | 4.15 | 4.21 | 4.29 | 4.44 |
| | 2800 | TC | 69.5 | 70.3 | 75.5 | 85.2 | 65.2 | 67.6 | 73.1 | 82.8 | 59.5 | 63.8 | 69.5 | 79.1 | |
| | | SHC | 69.5 | 67.8 | 56.5 | 37.1 | 65.2 | 61.1 | 51.3 | 35.0 | 59.5 | 53.1 | 45.5 | 32.7 | |
| | | LDB | 54.52 | 55.26 | 59.51 | 66.59 | 50.10 | 52.17 | 56.76 | 64.18 | 43.66 | 47.76 | 52.54 | 60.36 | |
| | | LWB | 46.09 | 52.11 | 57.48 | 66.04 | 43.96 | 49.87 | 55.21 | 63.86 | 40.70 | 46.22 | 51.55 | 60.31 | |
| | | | kW | 3.84 | 3.85 | 3.89 | 3.97 | 3.81 | 3.83 | 3.87 | 3.95 | 3.77 | 3.80 | 3.84 | 3.92 |
| | 3500 | TC | 70.0 | 70.9 | 76.3 | 86.2 | 65.6 | 68.0 | 73.8 | 83.8 | 59.7 | 64.2 | 70.0 | 79.8 | |
| | | SHC | 70.0 | 68.1 | 56.8 | 37.5 | 65.6 | 61.3 | 51.6 | 35.4 | 59.7 | 53.3 | 45.7 | 33.0 | |
| LDB | | 54.34 | 55.15 | 59.39 | 66.45 | 49.93 | 52.09 | 56.63 | 64.03 | 43.50 | 47.63 | 52.39 | 60.18 | | |
| LWB | | 46.01 | 52.03 | 57.37 | 65.92 | 43.87 | 49.79 | 55.10 | 63.72 | 40.62 | 46.10 | 51.42 | 60.14 | | |
| | | kW | 3.58 | 3.58 | 3.60 | 3.65 | 3.56 | 3.57 | 3.59 | 3.64 | 3.54 | 3.56 | 3.58 | 3.62 | |
| 95 | 2100 | TC | 63.4 | 63.5 | 67.6 | 75.8 | 59.8 | 60.9 | 65.7 | 74.0 | 54.9 | 57.8 | 62.8 | 71.1 | |
| | | SHC | 63.4 | 63.5 | 53.3 | 33.9 | 59.8 | 57.7 | 48.2 | 31.9 | 54.9 | 50.2 | 42.5 | 29.7 | |
| | | LDB | 56.74 | 56.84 | 60.66 | 67.73 | 52.58 | 53.68 | 58.16 | 65.57 | 46.46 | 49.52 | 54.32 | 62.13 | |
| | | LWB | 47.14 | 53.16 | 58.57 | 67.11 | 45.16 | 51.21 | 56.55 | 65.18 | 42.14 | 47.93 | 53.26 | 62.00 | |
| | | | kW | 5.49 | 5.49 | 5.56 | 5.71 | 5.43 | 5.44 | 5.53 | 5.68 | 5.29 | 5.39 | 5.48 | 5.63 |
| | 2800 | TC | 64.3 | 64.5 | 68.8 | 77.5 | 60.5 | 61.9 | 66.8 | 75.5 | 55.3 | 58.5 | 63.7 | 72.4 | |
| | | SHC | 64.3 | 64.5 | 53.7 | 34.4 | 60.5 | 58.1 | 48.6 | 32.4 | 55.3 | 50.4 | 42.9 | 30.2 | |
| | | LDB | 56.44 | 56.48 | 60.53 | 67.54 | 52.26 | 53.49 | 57.99 | 65.34 | 46.21 | 49.36 | 54.11 | 61.85 | |
| | | LWB | 46.99 | 53.01 | 58.41 | 66.92 | 45.01 | 51.02 | 56.36 | 64.96 | 42.01 | 47.73 | 53.03 | 61.73 | |
| | | | kW | 5.00 | 5.00 | 5.04 | 5.12 | 4.96 | 4.98 | 5.02 | 5.10 | 4.92 | 4.95 | 4.99 | 5.07 |
| | 3500 | TC | 64.8 | 65.0 | 69.6 | 78.6 | 61.0 | 62.4 | 67.5 | 76.5 | 55.7 | 59.0 | 64.3 | 73.3 | |
| | | SHC | 64.8 | 65.0 | 54.1 | 34.8 | 61.0 | 58.4 | 48.9 | 32.8 | 55.7 | 50.7 | 43.2 | 30.5 | |
| LDB | | 56.23 | 56.29 | 60.39 | 67.40 | 52.05 | 53.36 | 57.84 | 65.18 | 45.99 | 49.20 | 53.93 | 61.66 | | |
| LWB | | 46.90 | 52.93 | 58.30 | 66.80 | 44.91 | 50.91 | 56.23 | 64.81 | 41.90 | 47.59 | 52.88 | 61.55 | | |
| | | kW | 4.71 | 4.72 | 4.74 | 4.78 | 4.70 | 4.70 | 4.73 | 4.77 | 4.67 | 4.69 | 4.71 | 4.76 | |
| 105 | 2100 | TC | 60.4 | 60.5 | 63.8 | 71.6 | 57.1 | 57.7 | 62.2 | 70.0 | 52.4 | 54.8 | 59.5 | 67.4 | |
| | | SHC | 60.4 | 60.5 | 51.8 | 32.5 | 57.1 | 56.0 | 46.7 | 30.5 | 52.4 | 48.7 | 41.1 | 28.3 | |
| | | LDB | 57.84 | 57.93 | 61.22 | 68.24 | 53.82 | 54.46 | 58.84 | 66.20 | 47.96 | 50.43 | 55.18 | 62.95 | |
| | | LWB | 47.64 | 53.62 | 59.08 | 67.59 | 45.76 | 51.83 | 57.17 | 65.77 | 42.90 | 48.76 | 54.07 | 62.78 | |
| | | | kW | 6.12 | 6.12 | 6.18 | 6.33 | 6.06 | 6.07 | 6.15 | 6.30 | 5.97 | 6.02 | 6.11 | 6.25 |
| | 2800 | TC | 61.3 | 61.4 | 65.0 | 73.3 | 57.8 | 58.7 | 63.2 | 71.5 | 53.0 | 55.6 | 60.4 | 68.7 | |
| | | SHC | 61.3 | 61.4 | 52.1 | 33.0 | 57.8 | 56.5 | 47.1 | 31.0 | 53.0 | 49.1 | 41.4 | 28.8 | |
| | | LDB | 57.52 | 57.61 | 61.09 | 68.06 | 53.49 | 54.26 | 58.67 | 65.98 | 47.63 | 50.19 | 54.97 | 62.67 | |
| | | LWB | 47.50 | 53.48 | 58.92 | 67.40 | 45.61 | 51.63 | 56.99 | 65.55 | 42.73 | 48.52 | 53.85 | 62.51 | |
| | | | kW | 5.64 | 5.64 | 5.67 | 5.76 | 5.60 | 5.61 | 5.66 | 5.74 | 5.55 | 5.58 | 5.63 | 5.71 |
| | 3500 | TC | 61.9 | 62.0 | 65.9 | 74.4 | 58.3 | 59.3 | 64.0 | 72.6 | 53.4 | 56.0 | 61.1 | 69.6 | |
| | | SHC | 61.9 | 62.0 | 52.5 | 33.4 | 58.3 | 56.8 | 47.4 | 31.4 | 53.4 | 49.3 | 41.8 | 29.2 | |
| LDB | | 57.29 | 57.39 | 60.94 | 67.91 | 53.26 | 54.11 | 58.50 | 65.80 | 47.38 | 50.08 | 54.78 | 62.46 | | |
| LWB | | 47.39 | 53.39 | 58.80 | 67.27 | 45.49 | 51.53 | 56.85 | 65.40 | 42.61 | 48.42 | 53.68 | 62.32 | | |
| | | kW | 5.35 | 5.35 | 5.37 | 5.42 | 5.33 | 5.34 | 5.36 | 5.41 | 5.30 | 5.32 | 5.34 | 5.39 | |
| 115 | 2100 | TC | 57.3 | 57.3 | 59.9 | 67.3 | 54.2 | 54.3 | 58.4 | 65.8 | 49.9 | 51.5 | 56.1 | 63.6 | |
| | | SHC | 57.3 | 57.3 | 50.2 | 31.0 | 54.2 | 54.3 | 45.1 | 29.1 | 49.9 | 47.1 | 39.6 | 27.0 | |
| | | LDB | 59.00 | 59.09 | 61.79 | 68.77 | 55.15 | 55.22 | 59.53 | 66.84 | 49.53 | 51.38 | 56.07 | 63.77 | |
| | | LWB | 48.18 | 54.09 | 59.60 | 68.07 | 46.39 | 52.48 | 57.82 | 66.37 | 43.68 | 49.64 | 54.92 | 63.57 | |
| | | | kW | 6.77 | 6.78 | 6.83 | 6.97 | 6.71 | 6.72 | 6.80 | 6.94 | 6.62 | 6.66 | 6.75 | 6.90 |
| | 2800 | TC | 58.3 | 58.3 | 61.2 | 68.9 | 55.1 | 55.4 | 59.6 | 67.4 | 50.6 | 52.4 | 57.1 | 64.9 | |
| | | SHC | 58.3 | 58.3 | 50.7 | 31.6 | 55.1 | 54.5 | 45.6 | 29.6 | 50.6 | 47.5 | 40.0 | 27.4 | |
| | | LDB | 58.63 | 58.72 | 61.62 | 68.58 | 54.76 | 55.16 | 59.33 | 66.61 | 49.11 | 51.15 | 55.82 | 63.49 | |
| | | LWB | 48.01 | 53.94 | 59.43 | 67.89 | 46.21 | 52.28 | 57.62 | 66.15 | 43.47 | 49.40 | 54.67 | 63.29 | |
| | | | kW | 6.30 | 6.30 | 6.33 | 6.41 | 6.26 | 6.27 | 6.31 | 6.40 | 6.21 | 6.23 | 6.29 | 6.37 |
| | 3500 | TC | 58.8 | 58.8 | 62.0 | 69.9 | 55.5 | 55.9 | 60.2 | 68.3 | 50.9 | 52.8 | 57.6 | 65.7 | |
| | | SHC | 58.8 | 58.8 | 51.0 | 31.9 | 55.5 | 54.9 | 45.9 | 29.9 | 50.9 | 47.7 | 40.2 | 27.7 | |
| LDB | | 58.45 | 58.54 | 61.49 | 68.46 | 54.58 | 54.99 | 59.21 | 66.47 | 48.92 | 51.03 | 55.69 | 63.32 | | |
| LWB | | 47.92 | 53.87 | 59.32 | 67.78 | 46.12 | 52.17 | 57.51 | 66.02 | 43.38 | 49.29 | 54.54 | 63.14 | | |
| | | kW | 6.02 | 6.02 | 6.03 | 6.08 | 6.00 | 6.00 | 6.02 | 6.07 | 5.97 | 5.98 | 6.01 | 6.06 | |

LEGEND

- BF — Bypass Factor
- ECT — Entering Condenser Temperature (F)
- EDB — Entering Dry Bulb (F)
- EWB — Entering Wet Bulb (F)
- LDB — Leaving Dry Bulb (F)
- LWB — Leaving Wet Bulb (F)
- SHC — Sensible Capacity (1000 Btu/hr)
- TC — Total Capacity (1000 Btu/hr)
- kW — Compressor Motor Power Input (kilowatts)

Performance data (cont)



GROSS COOLING CAPACITIES (cont)

50XCR08 (7 1/2 TONS) UNIT WITH 09XC08 (7 1/2 TONS) UNIT

| Entering Condenser Air | | BF | AIR ENTERING EVAPORATOR — 80 F Edb (F) - CFM | | | | | | | | | | | |
|------------------------|------|-------|--|-------|-------|-------|-------|-------|-------|-------|-------|-------|-------|-------|
| ECT (F) | CFM | | 3750 | | | | 3000 | | | | 2250 | | | |
| | | | Air Entering Evaporator — Ewb (F) | | | | | | | | | | | |
| | | | 57 | 62 | 67 | 75 | 57 | 62 | 67 | 75 | 57 | 62 | 67 | 75 |
| 0.30 | 0.11 | 0.10 | 0.06 | 0.43 | 0.20 | 0.13 | 0.12 | 0.52 | 0.31 | 0.17 | 0.16 | | | |
| 55 | 2625 | TC | 95.1 | 95.4 | 100.9 | 113.5 | 89.6 | 91.1 | 98.1 | 110.8 | 82.1 | 86.4 | 93.8 | 106.4 |
| | | SHC | 95.1 | 95.3 | 80.3 | 50.9 | 89.6 | 86.8 | 72.4 | 47.9 | 82.1 | 75.4 | 63.8 | 44.5 |
| | | LDB | 56.76 | 56.81 | 60.59 | 67.72 | 52.61 | 53.61 | 58.11 | 65.58 | 46.56 | 49.48 | 54.30 | 62.17 |
| | | LWB | 47.15 | 53.14 | 58.61 | 67.13 | 45.18 | 51.24 | 56.60 | 65.20 | 42.19 | 47.98 | 53.32 | 62.05 |
| | | kW | 3.96 | 3.98 | 4.08 | 4.33 | 3.86 | 3.89 | 4.02 | 4.27 | 3.72 | 3.80 | 3.94 | 4.18 |
| | 3500 | TC | 96.1 | 96.2 | 102.4 | 115.5 | 90.4 | 92.1 | 99.5 | 112.7 | 82.7 | 87.1 | 94.9 | 108.1 |
| | | SHC | 96.1 | 96.2 | 80.9 | 51.5 | 90.4 | 87.3 | 73.0 | 48.5 | 82.7 | 75.7 | 64.3 | 45.0 |
| | | LDB | 56.51 | 56.61 | 60.44 | 67.57 | 52.37 | 53.47 | 57.94 | 65.40 | 46.31 | 49.36 | 54.11 | 61.94 |
| | | LWB | 47.03 | 53.06 | 58.48 | 66.98 | 45.06 | 51.11 | 56.44 | 65.02 | 42.07 | 47.85 | 53.14 | 61.81 |
| | | kW | 3.54 | 3.54 | 3.62 | 3.81 | 3.46 | 3.48 | 3.58 | 3.77 | 3.36 | 3.42 | 3.52 | 3.70 |
| | 4300 | TC | 96.5 | 96.7 | 103.1 | 116.6 | 90.8 | 92.5 | 100.0 | 113.6 | 83.0 | 87.5 | 95.3 | 108.8 |
| | | SHC | 96.5 | 96.7 | 81.2 | 51.9 | 90.8 | 87.6 | 73.2 | 48.8 | 83.0 | 75.9 | 64.5 | 45.3 |
| LDB | | 56.41 | 56.49 | 60.37 | 67.49 | 52.24 | 53.39 | 57.88 | 65.30 | 46.19 | 49.26 | 54.04 | 61.83 | |
| LWB | | 46.98 | 53.02 | 58.42 | 66.90 | 45.00 | 51.06 | 56.38 | 64.93 | 42.01 | 47.77 | 53.07 | 61.71 | |
| | kW | 3.31 | 3.31 | 3.38 | 3.53 | 3.25 | 3.27 | 3.35 | 3.50 | 3.17 | 3.22 | 3.30 | 3.45 | |
| 75 | 2625 | TC | 88.9 | 89.0 | 93.2 | 105.0 | 84.0 | 84.5 | 90.8 | 102.6 | 77.2 | 80.1 | 87.0 | 98.8 |
| | | SHC | 88.9 | 89.0 | 77.1 | 48.0 | 84.0 | 83.2 | 69.4 | 45.0 | 77.2 | 72.3 | 60.9 | 41.7 |
| | | LDB | 58.27 | 58.36 | 61.34 | 68.43 | 54.32 | 54.72 | 59.01 | 66.44 | 48.53 | 50.72 | 55.49 | 63.28 |
| | | LWB | 47.84 | 53.79 | 59.30 | 67.77 | 46.00 | 52.10 | 57.46 | 66.00 | 43.18 | 49.13 | 54.44 | 63.09 |
| | | kW | 5.07 | 5.08 | 5.17 | 5.45 | 4.97 | 4.98 | 5.12 | 5.39 | 4.82 | 4.88 | 5.03 | 5.30 |
| | 3500 | TC | 89.9 | 89.9 | 94.7 | 106.8 | 84.8 | 85.5 | 92.0 | 104.3 | 77.8 | 81.0 | 88.0 | 100.3 |
| | | SHC | 89.9 | 89.9 | 77.8 | 48.6 | 84.8 | 83.7 | 69.9 | 45.6 | 77.8 | 72.7 | 61.3 | 42.2 |
| | | LDB | 58.04 | 58.13 | 61.18 | 68.29 | 54.08 | 54.56 | 58.89 | 66.27 | 48.30 | 50.54 | 55.32 | 63.08 |
| | | LWB | 47.74 | 53.70 | 59.17 | 67.64 | 45.88 | 51.97 | 57.32 | 65.84 | 43.07 | 48.98 | 54.28 | 62.89 |
| | | kW | 4.59 | 4.59 | 4.66 | 4.86 | 4.51 | 4.52 | 4.62 | 4.82 | 4.40 | 4.45 | 4.56 | 4.75 |
| | 4300 | TC | 90.4 | 90.5 | 95.4 | 107.9 | 85.3 | 86.0 | 92.7 | 105.3 | 78.1 | 81.3 | 88.6 | 101.1 |
| | | SHC | 90.4 | 90.5 | 78.1 | 48.9 | 85.3 | 84.0 | 70.2 | 45.9 | 78.1 | 72.9 | 61.6 | 42.5 |
| LDB | | 57.90 | 58.00 | 61.11 | 68.19 | 53.94 | 54.47 | 58.79 | 66.17 | 48.17 | 50.48 | 55.21 | 62.95 | |
| LWB | | 47.67 | 53.64 | 59.11 | 67.55 | 45.82 | 51.90 | 57.24 | 65.74 | 43.00 | 48.91 | 54.18 | 62.78 | |
| | kW | 4.33 | 4.33 | 4.39 | 4.55 | 4.27 | 4.28 | 4.36 | 4.52 | 4.18 | 4.22 | 4.31 | 4.47 | |
| 95 | 2625 | TC | 82.1 | 82.2 | 84.7 | 95.4 | 77.8 | 77.9 | 82.6 | 93.4 | 71.8 | 73.4 | 79.7 | 90.3 |
| | | SHC | 82.1 | 82.2 | 73.8 | 44.8 | 77.8 | 77.9 | 66.2 | 41.9 | 71.8 | 68.9 | 57.7 | 38.6 |
| | | LDB | 59.93 | 60.01 | 62.15 | 69.19 | 56.21 | 56.31 | 60.00 | 67.37 | 50.75 | 52.08 | 56.74 | 64.49 |
| | | LWB | 48.60 | 54.47 | 60.06 | 68.48 | 46.89 | 52.94 | 58.39 | 66.89 | 44.28 | 50.34 | 55.63 | 64.25 |
| | | kW | 6.38 | 6.38 | 6.45 | 6.73 | 6.27 | 6.27 | 6.39 | 6.68 | 6.11 | 6.15 | 6.31 | 6.60 |
| | 3500 | TC | 82.9 | 83.0 | 86.1 | 97.1 | 78.5 | 78.5 | 83.8 | 95.0 | 72.2 | 74.1 | 80.4 | 91.7 |
| | | SHC | 82.9 | 83.0 | 74.3 | 45.4 | 78.5 | 78.5 | 66.5 | 42.4 | 72.2 | 69.3 | 58.1 | 39.1 |
| | | LDB | 59.73 | 59.82 | 62.02 | 69.06 | 56.03 | 56.13 | 59.89 | 67.21 | 50.58 | 51.93 | 56.61 | 64.30 |
| | | LWB | 48.51 | 54.39 | 59.93 | 68.35 | 46.80 | 52.86 | 58.26 | 66.73 | 44.19 | 50.22 | 55.51 | 64.06 |
| | | kW | 5.84 | 5.85 | 5.90 | 6.11 | 5.76 | 5.76 | 5.86 | 6.07 | 5.65 | 5.68 | 5.80 | 6.01 |
| | 4300 | TC | 83.5 | 83.6 | 86.9 | 98.2 | 79.0 | 79.1 | 84.5 | 96.0 | 72.6 | 74.5 | 81.1 | 92.6 |
| | | SHC | 83.5 | 83.6 | 74.6 | 45.8 | 79.0 | 79.1 | 66.9 | 42.8 | 72.6 | 69.4 | 58.3 | 39.4 |
| LDB | | 59.59 | 59.67 | 61.95 | 68.96 | 55.87 | 55.97 | 59.79 | 67.11 | 50.42 | 51.86 | 56.49 | 64.17 | |
| LWB | | 48.45 | 54.33 | 59.87 | 68.27 | 46.73 | 52.80 | 58.18 | 66.63 | 44.12 | 50.16 | 55.41 | 63.94 | |
| | kW | 5.56 | 5.56 | 5.61 | 5.78 | 5.50 | 5.50 | 5.58 | 5.74 | 5.41 | 5.43 | 5.53 | 5.69 | |
| 105 | 2625 | TC | 78.3 | 78.3 | 80.2 | 90.2 | 74.4 | 74.4 | 78.2 | 88.6 | 68.7 | 69.5 | 75.6 | 85.8 |
| | | SHC | 78.3 | 78.3 | 71.9 | 43.1 | 74.4 | 74.4 | 64.4 | 40.3 | 68.7 | 67.0 | 56.1 | 37.1 |
| | | LDB | 60.86 | 60.95 | 62.61 | 69.60 | 57.28 | 57.38 | 60.54 | 67.84 | 52.00 | 52.86 | 57.39 | 65.10 |
| | | LWB | 49.02 | 54.85 | 60.46 | 68.86 | 47.39 | 53.39 | 58.90 | 67.34 | 44.89 | 51.04 | 56.29 | 64.84 |
| | | kW | 7.09 | 7.09 | 7.14 | 7.43 | 6.98 | 6.98 | 7.09 | 7.38 | 6.82 | 6.85 | 7.01 | 7.30 |
| | 3500 | TC | 79.1 | 79.1 | 81.6 | 91.9 | 75.0 | 75.1 | 79.5 | 90.0 | 69.2 | 70.4 | 76.3 | 87.0 |
| | | SHC | 79.1 | 79.1 | 72.4 | 43.6 | 75.0 | 75.1 | 64.9 | 40.7 | 69.2 | 67.4 | 56.3 | 37.5 |
| | | LDB | 60.67 | 60.75 | 62.49 | 69.47 | 57.09 | 57.18 | 60.39 | 67.72 | 51.82 | 52.71 | 57.31 | 64.95 |
| | | LWB | 48.94 | 54.77 | 60.34 | 68.74 | 47.30 | 53.30 | 58.75 | 67.21 | 44.80 | 50.88 | 56.18 | 64.69 |
| | | kW | 6.55 | 6.55 | 6.60 | 6.81 | 6.47 | 6.47 | 6.56 | 6.77 | 6.35 | 6.37 | 6.49 | 6.71 |
| | 4300 | TC | 79.7 | 79.8 | 82.3 | 93.0 | 75.5 | 75.6 | 80.0 | 91.0 | 69.6 | 70.8 | 76.9 | 87.9 |
| | | SHC | 79.7 | 79.8 | 72.8 | 44.0 | 75.5 | 75.6 | 65.1 | 41.1 | 69.6 | 67.6 | 56.6 | 37.8 |
| LDB | | 60.52 | 60.60 | 62.41 | 69.38 | 56.93 | 57.02 | 60.33 | 67.61 | 51.66 | 52.60 | 57.18 | 64.82 | |
| LWB | | 48.87 | 54.71 | 60.27 | 68.66 | 47.22 | 53.24 | 58.69 | 67.11 | 44.72 | 50.80 | 56.07 | 64.57 | |
| | kW | 6.26 | 6.26 | 6.30 | 6.47 | 6.19 | 6.19 | 6.26 | 6.44 | 6.10 | 6.12 | 6.21 | 6.39 | |
| 115 | 2625 | TC | 74.1 | 74.1 | 75.4 | 84.8 | 70.5 | 70.5 | 73.6 | 83.2 | 65.3 | 65.6 | 71.0 | 80.7 |
| | | SHC | 74.1 | 74.1 | 69.8 | 41.4 | 70.5 | 70.5 | 62.5 | 38.5 | 65.3 | 64.9 | 54.2 | 35.3 |
| | | LDB | 61.90 | 61.98 | 63.11 | 70.03 | 58.47 | 58.56 | 61.10 | 68.39 | 53.40 | 53.68 | 58.15 | 65.81 |
| | | LWB | 49.49 | 55.26 | 60.87 | 69.25 | 47.94 | 53.87 | 59.41 | 67.84 | 45.56 | 51.71 | 57.01 | 65.51 |
| | | kW | 7.83 | 7.84 | 7.87 | 8.16 | 7.73 | 7.73 | 7.82 | 8.11 | 7.57 | 7.58 | 7.74 | 8.04 |
| | 3500 | TC | 75.0 | 75.1 | 76.7 | 86.3 | 71.2 | 71.3 | 74.8 | 84.7 | 65.9 | 66.5 | 71.9 | 82.0 |
| | | SHC | 75.0 | 75.1 | 70.3 | 41.8 | 71.2 | 71.3 | 63.0 | 39.0 | 65.9 | 65.2 | 54.5 | 35.7 |
| | | LDB | 61.66 | 61.74 | 62.99 | 69.91 | 58.24 | 58.33 | 60.96 | 68.25 | 53.17 | 53.57 | 58.03 | 65.64 |
| | | LWB | 49.38 | 55.17 | 60.76 | 69.14 | 47.83 | 53.78 | 59.28 | 67.70 | 45.45 | 51.55 | 56.87 | 65.34 |
| | | kW | 7.30 | 7.30 | 7.33 | 7.54 | 7.22 | 7.22 | 7.29 | 7.50 | 7.10 | 7.11 | 7.23 | 7.45 |
| | 4300 | TC | 75.7 | 75.7 | 77.4 | 87.4 | 71.8 | 71.8 | 75.5 | 85.7 | 66.3 | 66.9 | 72.5 | 82.9 |
| | | SHC | 75.7 | 75.7 | 70.7 | 42.2 | 71.8 | 71.8 | 63.3 | 39.3 | 66.3 | 65.5 | 54.8 | 36.1 |
| LDB | | 61.51 | 61.59 | 62.91 | 69.82 | 58.07 | 58.16 | 60.88 | 68.15 | 53.00 | 53.46 | 57.91 | 65.51 | |
| LWB | | 49.31 | 55.10 | 60.70 | 69.06 | 47.75 | 53.71 | 59.20 | 67.61 | 45.37 | 51.48 | 56.76 | 65.22 | |
| | kW | 7.00 | 7.01 | 7.03 | 7.20 | 6.94 | 6.94 | 7.00 | 7.17 | 6.85 | 6.86 | 6.95 | 7.13 | |

LEGEND

- BF — Bypass Factor
- ECT — Entering Condenser Temperature (F)
- EDB — Entering Dry Bulb (F)
- EWB — Entering Wet Bulb (F)
- LDB — Leaving Dry Bulb (F)
- LWB — Leaving Wet Bulb (F)
- SHC — Sensible Capacity (1000 Btu/hr)
- TC — Total Capacity (1000 Btu/hr)
- kW — Compressor Motor Power Input (kilowatts)



GROSS COOLING CAPACITIES (cont)

50XCR12 (10 TONS) UNIT WITH 09XC12 (10 TONS) UNIT

| Entering Condenser Air | | BF | AIR ENTERING EVAPORATOR — 80 F Edb (F) - CFM | | | | | | | | | | | |
|------------------------|------|-------|--|-------|-------|-------|-------|-------|-------|-------|-------|-------|-------|-------|
| ECT (F) | CFM | | 5000 | | | | 4000 | | | | 3000 | | | |
| | | | Air Entering Evaporator — Ewb (F) | | | | | | | | | | | |
| | | | 57 | 62 | 67 | 75 | 57 | 62 | 67 | 75 | 57 | 62 | 67 | 75 |
| 0.23 | 0.06 | 0.05 | 0.03 | 0.37 | 0.13 | 0.08 | 0.06 | 0.46 | 0.23 | 0.11 | 0.10 | | | |
| 55 | 4800 | TC | 140.7 | 140.9 | 151.0 | 171.6 | 131.8 | 135.1 | 146.3 | 166.9 | 119.7 | 127.4 | 139.0 | 159.3 |
| | | SHC | 140.7 | 140.9 | 117.2 | 75.7 | 131.8 | 125.6 | 105.3 | 71.0 | 119.7 | 108.2 | 92.4 | 65.8 |
| | | LDB | 54.21 | 54.30 | 58.75 | 66.32 | 49.79 | 51.37 | 56.13 | 63.98 | 43.44 | 47.13 | 52.10 | 60.24 |
| | | LWB | 45.94 | 52.09 | 57.48 | 65.97 | 43.81 | 49.88 | 55.21 | 63.77 | 40.59 | 46.26 | 51.54 | 60.18 |
| | 6000 | KW | 5.94 | 5.94 | 6.11 | 6.43 | 5.81 | 5.86 | 6.03 | 6.35 | 5.63 | 5.75 | 5.92 | 6.23 |
| | | TC | 141.6 | 141.8 | 152.6 | 173.7 | 132.5 | 136.0 | 147.7 | 168.7 | 120.2 | 128.2 | 140.0 | 160.8 |
| | | SHC | 141.6 | 141.8 | 117.9 | 76.4 | 132.5 | 126.1 | 105.9 | 71.6 | 120.2 | 108.6 | 92.9 | 66.4 |
| | | LDB | 54.03 | 54.13 | 58.62 | 66.19 | 49.62 | 51.26 | 56.00 | 63.83 | 43.27 | 47.01 | 51.96 | 60.07 |
| | 7600 | LWB | 45.86 | 52.02 | 57.37 | 65.85 | 43.72 | 49.79 | 55.08 | 63.63 | 40.50 | 46.14 | 51.41 | 60.02 |
| | | KW | 5.32 | 5.32 | 5.43 | 5.65 | 5.24 | 5.27 | 5.38 | 5.60 | 5.12 | 5.19 | 5.31 | 5.51 |
| | | TC | 142.1 | 142.6 | 153.3 | 174.8 | 132.9 | 136.5 | 148.3 | 169.6 | 120.5 | 128.6 | 140.5 | 161.5 |
| | | SHC | 142.1 | 141.3 | 118.1 | 76.7 | 132.9 | 126.3 | 106.2 | 71.9 | 120.5 | 108.8 | 93.1 | 66.6 |
| 75 | 4800 | LDB | 53.95 | 54.23 | 58.57 | 66.13 | 49.54 | 51.21 | 55.94 | 63.76 | 43.18 | 46.95 | 51.89 | 59.99 |
| | | LWB | 45.82 | 51.96 | 57.32 | 65.78 | 43.68 | 49.74 | 55.03 | 63.56 | 40.46 | 46.08 | 51.34 | 59.94 |
| | | KW | 4.98 | 4.97 | 5.06 | 5.22 | 4.91 | 4.94 | 5.02 | 5.18 | 4.83 | 4.88 | 4.97 | 5.12 |
| | | TC | 131.8 | 132.0 | 140.0 | 159.5 | 123.7 | 125.4 | 135.8 | 155.2 | 112.6 | 118.3 | 129.3 | 148.5 |
| | 6000 | SHC | 131.8 | 132.0 | 112.8 | 71.6 | 123.7 | 120.7 | 101.0 | 66.9 | 112.6 | 103.8 | 88.1 | 61.7 |
| | | LDB | 55.83 | 55.93 | 59.54 | 67.05 | 51.65 | 52.50 | 57.11 | 64.88 | 45.59 | 48.47 | 53.38 | 61.44 |
| | | LWB | 46.71 | 52.78 | 58.24 | 66.66 | 44.71 | 50.85 | 56.16 | 64.65 | 41.70 | 47.54 | 52.79 | 61.35 |
| | | KW | 7.67 | 7.67 | 7.81 | 8.18 | 7.52 | 7.55 | 7.74 | 8.10 | 7.33 | 7.43 | 7.62 | 7.97 |
| | 7600 | TC | 132.7 | 132.9 | 141.2 | 161.3 | 124.5 | 126.2 | 136.9 | 156.8 | 113.2 | 119.1 | 130.2 | 149.8 |
| | | SHC | 132.7 | 132.9 | 113.3 | 72.2 | 124.5 | 121.1 | 101.4 | 67.5 | 113.2 | 104.2 | 88.5 | 62.2 |
| | | LDB | 55.67 | 55.77 | 59.44 | 66.94 | 51.48 | 52.39 | 57.00 | 64.76 | 45.41 | 48.35 | 53.26 | 61.29 |
| | | LWB | 46.63 | 52.71 | 58.15 | 66.56 | 44.63 | 50.77 | 56.06 | 64.53 | 41.61 | 47.43 | 52.67 | 61.21 |
| 95 | 4800 | KW | 6.95 | 6.95 | 7.05 | 7.29 | 6.86 | 6.88 | 7.00 | 7.24 | 6.73 | 6.80 | 6.92 | 7.15 |
| | | TC | 133.2 | 133.3 | 141.9 | 162.1 | 124.9 | 126.7 | 137.5 | 157.6 | 113.5 | 119.5 | 130.7 | 150.5 |
| | | SHC | 133.2 | 133.3 | 113.6 | 72.5 | 124.9 | 121.4 | 101.7 | 67.7 | 113.5 | 104.4 | 88.8 | 62.5 |
| | | LDB | 55.58 | 55.68 | 59.40 | 66.89 | 51.39 | 52.34 | 56.95 | 64.70 | 45.32 | 48.29 | 53.19 | 61.21 |
| | 6000 | LWB | 46.59 | 52.68 | 58.11 | 66.52 | 44.59 | 50.72 | 56.01 | 64.47 | 41.56 | 47.38 | 52.61 | 61.14 |
| | | KW | 6.55 | 6.55 | 6.62 | 6.79 | 6.48 | 6.50 | 6.58 | 6.75 | 6.39 | 6.44 | 6.53 | 6.69 |
| | | TC | 121.9 | 122.0 | 127.6 | 145.4 | 114.7 | 114.9 | 123.9 | 141.9 | 104.7 | 108.3 | 118.3 | 136.2 |
| | | SHC | 121.9 | 122.0 | 107.9 | 67.0 | 114.7 | 114.9 | 96.2 | 62.4 | 104.7 | 98.9 | 83.5 | 57.3 |
| | 7600 | LDB | 57.65 | 57.75 | 60.43 | 67.88 | 53.72 | 53.81 | 58.19 | 65.90 | 48.02 | 49.95 | 54.78 | 62.76 |
| | | LWB | 47.56 | 53.54 | 59.08 | 67.46 | 45.71 | 51.89 | 57.21 | 65.63 | 42.92 | 48.94 | 54.16 | 62.64 |
| | | KW | 9.70 | 9.70 | 9.82 | 10.20 | 9.55 | 9.55 | 9.74 | 10.12 | 9.34 | 9.41 | 9.62 | 10.00 |
| | | TC | 122.8 | 122.9 | 128.7 | 147.1 | 115.4 | 115.6 | 124.9 | 143.3 | 105.3 | 109.1 | 119.2 | 137.4 |
| 105 | 4800 | SHC | 122.8 | 122.9 | 108.3 | 67.5 | 115.4 | 115.6 | 96.6 | 62.9 | 105.3 | 99.3 | 83.8 | 57.7 |
| | | LDB | 57.49 | 57.59 | 60.36 | 67.78 | 53.55 | 53.65 | 58.10 | 65.79 | 47.83 | 49.83 | 54.67 | 62.63 |
| | | LWB | 47.49 | 53.47 | 59.01 | 67.37 | 45.63 | 51.81 | 57.12 | 65.53 | 42.83 | 48.83 | 54.05 | 62.51 |
| | | KW | 8.91 | 8.91 | 8.99 | 9.25 | 8.61 | 8.82 | 8.92 | 9.19 | 8.68 | 8.73 | 8.87 | 9.11 |
| | 6000 | TC | 123.2 | 123.3 | 129.3 | 147.9 | 115.8 | 116.0 | 125.5 | 144.1 | 105.6 | 109.4 | 119.7 | 138.0 |
| | | SHC | 123.2 | 123.3 | 108.5 | 67.8 | 115.8 | 116.0 | 96.8 | 63.1 | 105.6 | 99.5 | 84.0 | 58.0 |
| | | LDB | 57.42 | 57.51 | 60.31 | 67.73 | 53.47 | 53.56 | 58.06 | 65.74 | 47.74 | 49.77 | 54.61 | 62.56 |
| | | LWB | 47.45 | 53.44 | 58.97 | 67.33 | 45.59 | 51.78 | 57.07 | 65.47 | 42.79 | 48.78 | 53.99 | 62.45 |
| | 7600 | KW | 8.47 | 8.47 | 8.52 | 8.70 | 8.40 | 8.40 | 8.49 | 8.67 | 8.30 | 8.34 | 8.43 | 8.61 |
| | | TC | 116.5 | 116.6 | 120.9 | 137.9 | 109.8 | 109.9 | 117.5 | 134.6 | 100.4 | 102.9 | 112.5 | 129.4 |
| | | SHC | 116.5 | 116.6 | 105.2 | 64.6 | 109.8 | 109.9 | 93.6 | 59.9 | 100.4 | 96.3 | 81.0 | 54.9 |
| | | LDB | 58.64 | 58.73 | 60.93 | 68.32 | 54.84 | 54.94 | 58.78 | 66.45 | 49.32 | 50.73 | 55.53 | 63.47 |
| 115 | 4800 | LWB | 48.01 | 53.94 | 59.53 | 67.89 | 46.25 | 52.37 | 57.76 | 66.16 | 43.57 | 49.66 | 54.88 | 63.33 |
| | | KW | 10.83 | 10.84 | 10.93 | 11.31 | 10.68 | 10.69 | 10.86 | 11.24 | 10.47 | 10.53 | 10.74 | 11.12 |
| | | TC | 117.3 | 117.4 | 121.9 | 139.4 | 110.5 | 110.6 | 118.5 | 136.0 | 101.0 | 103.7 | 113.3 | 130.6 |
| | | SHC | 117.3 | 117.4 | 105.6 | 65.1 | 110.5 | 110.6 | 94.0 | 60.4 | 101.0 | 96.6 | 81.3 | 55.3 |
| | 6000 | LDB | 58.49 | 58.58 | 60.85 | 68.23 | 54.68 | 54.78 | 58.69 | 66.34 | 49.14 | 50.63 | 55.42 | 63.34 |
| | | LWB | 47.95 | 53.88 | 59.46 | 67.80 | 46.17 | 52.30 | 57.68 | 66.06 | 43.48 | 49.56 | 54.78 | 63.21 |
| | | KW | 10.02 | 10.02 | 10.09 | 10.35 | 9.92 | 9.93 | 10.04 | 10.30 | 9.79 | 9.82 | 9.97 | 10.22 |
| | | TC | 117.7 | 117.8 | 122.5 | 140.1 | 110.8 | 111.0 | 119.0 | 136.7 | 101.3 | 104.0 | 113.7 | 131.2 |
| | 7600 | SHC | 117.7 | 117.8 | 105.8 | 65.3 | 110.8 | 111.0 | 94.2 | 60.6 | 101.3 | 96.8 | 81.5 | 55.5 |
| | | LDB | 58.42 | 58.51 | 60.81 | 68.19 | 54.60 | 54.71 | 58.64 | 66.29 | 49.06 | 50.58 | 55.37 | 63.28 |
| | | LWB | 47.91 | 53.85 | 59.42 | 67.76 | 46.13 | 52.26 | 57.64 | 66.01 | 43.44 | 49.52 | 54.73 | 63.15 |
| | | KW | 9.56 | 9.56 | 9.61 | 9.79 | 9.49 | 9.49 | 9.57 | 9.76 | 9.39 | 9.42 | 9.52 | 9.70 |
| 115 | 4800 | TC | 110.8 | 110.9 | 114.0 | 129.9 | 104.5 | 104.7 | 110.8 | 127.0 | 95.9 | 97.3 | 106.2 | 122.3 |
| | | SHC | 110.8 | 110.9 | 102.3 | 62.0 | 104.5 | 104.7 | 90.9 | 57.4 | 95.9 | 93.5 | 78.4 | 52.4 |
| | | LDB | 59.69 | 59.78 | 61.44 | 68.78 | 56.04 | 56.14 | 59.38 | 67.02 | 50.71 | 51.57 | 56.30 | 64.21 |
| | | LWB | 48.49 | 54.37 | 59.99 | 68.33 | 46.81 | 52.87 | 58.34 | 66.71 | 44.26 | 50.42 | 55.64 | 64.05 |
| | 6000 | KW | 12.03 | 12.04 | 12.11 | 12.49 | 11.89 | 11.89 | 12.04 | 12.42 | 11.69 | 11.72 | 11.93 | 12.31 |
| | | TC | 111.6 | 111.7 | 114.9 | 131.3 | 105.2 | 105.3 | 111.7 | 128.2 | 96.3 | 97.9 | 107.0 | 123.4 |
| | | SHC | 111.6 | 111.7 | 102.7 | 62.5 | 105.2 | 105.3 | 91.3 | 57.8 | 96.3 | 93.8 | 78.7 | 52.8 |
| | | LDB | 59.55 | 59.63 | 61.38 | 68.70 | 55.90 | 56.00 | 59.31 | 66.92 | 50.58 | 51.50 | 56.21 | 64.10 |
| | 7600 | LWB | 48.43 | 54.31 | 59.93 | 68.25 | 46.74 | 52.81 | 58.26 | 66.62 | 44.19 | 50.34 | 55.54 | 63.95 |
| | | KW | 11.22 | 11.22 | 11.27 | 11.52 | 11.12 | 11.12 | 11.22 | 11.48 | 10.98 | 11.00 | 11.15 | 11.41 |
| | | TC | 111.9 | 112.0 | 115.4 | 132.0 | 105.5 | 105.7 | 112.1 | 128.9 | 96.6 | 98.3 | 107.4 | 124.0 |
| | | SHC | 111.9 | 112.0 | 102.9 | 62.7 | 105.5 | 105.7 | 91.5 | 58.1 | 96.6 | 94.0 | 78.9 | 53.0 |
| 115 | LDB | 59.48 | 59.56 | 61.34 | 68.66 | 55.82 | 55.91 | 59.26 | 66.88 | 50.48 | 51.44 | 56.15 | 64.04 | |
| | LWB | 48.40 | 54.28 | 59.90 | 68.22 | 46.70 | 52.77 | 58.23 | 66.57 | 44.14 | 50.29 | 55.49 | 63.89 | |
| | KW | 10.75 | 10.75 | 10.79 | 10.97 | 10.68 | 10.68 | 10.75 | 10.93 | 10.58 | 10.60 | 10.70 | 10.88 | |

LEGEND

- BF — Bypass Factor
- ECT — Entering Condenser Temperature (F)
- EDB — Entering Dry Bulb (F)
- EWB — Entering Wet Bulb (F)
- LDB — Leaving Dry Bulb (F)
- LWB — Leaving Wet Bulb (F)
- SHC — Sensible Capacity (1000 Btu/hr)
- TC — Total Capacity (1000 Btu/hr)
- KW — Compressor Motor Power Input (kilowatts)

Performance data (cont)



GROSS COOLING CAPACITIES (cont)

50XCR14 (12 TONS) UNIT WITH 09XC14 (12 TONS) UNIT

| Entering Condenser Air | | BF | AIR ENTERING EVAPORATOR — 80 F Edb (F) — CFM | | | | | | | | | | | |
|------------------------|------|------|--|-------|-------|-------|-------|-------|-------|-------|-------|-------|-------|-------|
| ECT (F) | CFM | | 6000 | | | | 4800 | | | | 3600 | | | |
| | | | Air Entering Evaporator — Ewb (F) | | | | | | | | | | | |
| | | | 57 | 62 | 67 | 75 | 57 | 62 | 67 | 75 | 57 | 62 | 67 | 75 |
| 0.24 | 0.09 | 0.08 | 0.05 | 0.38 | 0.15 | 0.12 | 0.10 | 0.47 | 0.25 | 0.15 | 0.13 | | | |
| 55 | 6000 | TC | 165.3 | 166.3 | 178.4 | 202.5 | 155.0 | 159.4 | 172.8 | 196.7 | 141.0 | 150.5 | 164.0 | 187.6 |
| | | SHC | 165.3 | 163.1 | 136.5 | 88.8 | 155.0 | 146.7 | 123.2 | 83.4 | 141.0 | 127.1 | 108.6 | 77.5 |
| | | LDB | 54.74 | 55.21 | 59.37 | 66.62 | 50.40 | 52.14 | 56.73 | 64.30 | 44.09 | 47.82 | 52.68 | 60.60 |
| | | LWB | 46.20 | 52.28 | 57.65 | 66.14 | 44.11 | 50.11 | 55.43 | 64.00 | 40.93 | 46.54 | 51.85 | 60.51 |
| | 8000 | TC | 165.8 | 166.9 | 179.2 | 204.0 | 155.5 | 159.9 | 173.5 | 197.8 | 141.3 | 150.8 | 164.6 | 188.6 |
| | | SHC | 165.8 | 163.7 | 136.8 | 89.3 | 155.5 | 147.0 | 123.5 | 83.8 | 141.3 | 127.2 | 108.8 | 77.8 |
| | | LDB | 54.66 | 55.13 | 59.33 | 66.54 | 50.31 | 52.08 | 56.69 | 64.23 | 44.01 | 47.81 | 52.63 | 60.51 |
| | | LWB | 46.17 | 52.24 | 57.60 | 66.07 | 44.07 | 50.07 | 55.38 | 63.93 | 40.89 | 46.51 | 51.79 | 60.42 |
| | 9500 | TC | 166.2 | 167.2 | 179.7 | 204.6 | 155.8 | 160.2 | 174.0 | 198.5 | 141.6 | 151.2 | 165.0 | 189.2 |
| | | SHC | 166.2 | 163.8 | 137.0 | 89.5 | 155.8 | 147.1 | 123.7 | 84.1 | 141.6 | 127.4 | 109.0 | 78.1 |
| | | LDB | 54.61 | 55.10 | 59.29 | 66.51 | 50.25 | 52.06 | 56.64 | 64.18 | 43.95 | 47.76 | 52.58 | 60.46 |
| | | LWB | 46.14 | 52.22 | 57.57 | 66.04 | 44.04 | 50.05 | 55.34 | 63.88 | 40.86 | 46.47 | 51.75 | 60.37 |
| 75 | 6000 | TC | 155.1 | 155.3 | 165.2 | 187.7 | 145.8 | 148.1 | 160.3 | 182.7 | 133.1 | 140.1 | 152.7 | 174.9 |
| | | SHC | 155.1 | 153.3 | 131.2 | 83.8 | 145.8 | 141.1 | 118.0 | 78.5 | 133.1 | 122.0 | 103.6 | 72.7 |
| | | LDB | 56.31 | 56.40 | 60.17 | 67.37 | 52.15 | 53.20 | 57.71 | 65.22 | 46.11 | 49.13 | 53.94 | 61.79 |
| | | LWB | 46.94 | 52.99 | 58.41 | 66.85 | 44.96 | 51.05 | 56.36 | 64.88 | 41.97 | 47.77 | 53.05 | 61.65 |
| | 8000 | TC | 155.7 | 155.9 | 166.0 | 189.0 | 146.3 | 148.9 | 161.0 | 183.8 | 133.4 | 140.6 | 153.3 | 175.8 |
| | | SHC | 155.7 | 153.9 | 131.5 | 84.2 | 146.3 | 141.4 | 118.3 | 78.9 | 133.4 | 122.2 | 103.8 | 73.0 |
| | | LDB | 56.22 | 56.30 | 60.13 | 67.30 | 52.06 | 53.15 | 57.66 | 65.14 | 46.02 | 49.08 | 53.87 | 61.70 |
| | | LWB | 46.90 | 52.94 | 58.36 | 66.79 | 44.92 | 50.99 | 56.31 | 64.80 | 41.92 | 47.71 | 52.99 | 61.56 |
| | 9500 | TC | 156.1 | 156.2 | 166.6 | 189.8 | 146.7 | 149.2 | 161.6 | 184.6 | 133.7 | 141.0 | 153.8 | 176.4 |
| | | SHC | 156.1 | 154.4 | 131.8 | 84.5 | 146.7 | 141.5 | 118.5 | 79.2 | 133.7 | 122.4 | 104.0 | 73.3 |
| | | LDB | 56.15 | 56.26 | 60.09 | 67.26 | 51.99 | 53.12 | 57.61 | 65.09 | 45.95 | 49.02 | 53.82 | 61.64 |
| | | LWB | 46.87 | 52.92 | 58.33 | 66.75 | 44.89 | 50.97 | 56.27 | 64.76 | 41.89 | 47.67 | 52.94 | 61.51 |
| 95 | 6000 | TC | 143.5 | 143.6 | 150.6 | 171.0 | 135.3 | 135.9 | 146.4 | 166.9 | 124.1 | 127.8 | 140.0 | 160.6 |
| | | SHC | 143.5 | 143.6 | 125.4 | 78.3 | 135.3 | 134.3 | 112.3 | 73.1 | 124.1 | 115.9 | 98.1 | 67.5 |
| | | LDB | 58.08 | 58.17 | 61.05 | 68.19 | 54.17 | 54.48 | 58.78 | 66.22 | 48.39 | 50.65 | 55.31 | 63.08 |
| | | LWB | 47.76 | 53.72 | 59.23 | 67.63 | 45.93 | 52.05 | 57.38 | 65.84 | 43.12 | 49.19 | 54.37 | 62.89 |
| | 8000 | TC | 144.1 | 144.3 | 151.6 | 172.4 | 135.8 | 136.7 | 147.1 | 168.1 | 124.3 | 129.2 | 140.6 | 161.3 |
| | | SHC | 144.1 | 144.3 | 125.8 | 78.7 | 135.8 | 134.6 | 112.6 | 73.5 | 124.3 | 116.6 | 98.3 | 67.7 |
| | | LDB | 57.98 | 58.07 | 60.98 | 68.13 | 54.07 | 54.44 | 58.73 | 66.15 | 48.35 | 50.48 | 55.25 | 63.01 |
| | | LWB | 47.71 | 53.68 | 59.17 | 67.57 | 45.88 | 51.98 | 57.33 | 65.77 | 43.10 | 49.02 | 54.31 | 62.83 |
| | 9500 | TC | 144.6 | 144.8 | 152.1 | 173.3 | 136.2 | 137.0 | 147.7 | 168.9 | 124.7 | 129.4 | 141.2 | 162.0 |
| | | SHC | 144.6 | 144.8 | 126.0 | 79.1 | 136.2 | 134.8 | 112.9 | 73.8 | 124.7 | 116.7 | 98.6 | 68.0 |
| | | LDB | 57.90 | 58.00 | 60.96 | 68.08 | 53.98 | 54.40 | 58.68 | 66.10 | 48.26 | 50.44 | 55.18 | 62.95 |
| | | LWB | 47.68 | 53.65 | 59.15 | 67.53 | 45.84 | 51.96 | 57.28 | 65.72 | 43.05 | 49.00 | 54.25 | 62.77 |
| 105 | 6000 | TC | 137.3 | 137.4 | 142.6 | 162.4 | 129.7 | 129.6 | 138.8 | 158.6 | 119.0 | 122.1 | 133.3 | 152.6 |
| | | SHC | 137.3 | 137.4 | 122.2 | 75.6 | 129.7 | 129.6 | 109.3 | 70.4 | 119.0 | 113.2 | 95.4 | 64.7 |
| | | LDB | 59.03 | 59.12 | 61.53 | 68.60 | 55.24 | 55.38 | 59.36 | 66.74 | 49.70 | 51.34 | 55.99 | 63.77 |
| | | LWB | 48.20 | 54.11 | 59.68 | 68.04 | 46.44 | 52.56 | 57.93 | 66.34 | 43.77 | 49.83 | 55.05 | 63.57 |
| | 8000 | TC | 137.7 | 137.8 | 143.7 | 163.6 | 130.0 | 130.3 | 139.5 | 159.4 | 119.2 | 122.8 | 133.6 | 153.3 |
| | | SHC | 137.7 | 137.8 | 122.6 | 75.9 | 130.0 | 130.3 | 109.5 | 70.6 | 119.2 | 113.5 | 95.4 | 64.9 |
| | | LDB | 58.96 | 59.05 | 61.47 | 68.56 | 55.18 | 55.24 | 59.31 | 66.70 | 49.65 | 51.27 | 55.99 | 63.72 |
| | | LWB | 48.17 | 54.08 | 59.62 | 67.98 | 46.41 | 52.50 | 57.88 | 66.29 | 43.74 | 49.75 | 55.02 | 63.51 |
| | 9500 | TC | 138.2 | 138.4 | 144.1 | 164.3 | 130.5 | 130.6 | 140.2 | 160.2 | 119.6 | 123.1 | 134.2 | 154.0 |
| | | SHC | 138.2 | 138.4 | 122.8 | 76.1 | 130.5 | 130.6 | 109.8 | 70.9 | 119.6 | 113.6 | 95.6 | 65.1 |
| | | LDB | 58.88 | 58.97 | 61.44 | 68.52 | 55.09 | 55.19 | 59.25 | 66.65 | 49.54 | 51.23 | 55.92 | 63.66 |
| | | LWB | 48.13 | 54.05 | 59.59 | 67.95 | 46.37 | 52.47 | 57.83 | 66.25 | 43.69 | 49.72 | 54.96 | 63.46 |
| 115 | 6000 | TC | 130.4 | 130.5 | 134.2 | 152.8 | 123.4 | 123.5 | 130.6 | 149.5 | 113.4 | 115.2 | 125.4 | 144.1 |
| | | SHC | 130.4 | 130.5 | 118.8 | 72.5 | 123.4 | 123.5 | 106.0 | 67.4 | 113.4 | 109.7 | 92.0 | 61.7 |
| | | LDB | 60.08 | 60.16 | 62.04 | 69.07 | 56.44 | 56.54 | 59.97 | 67.31 | 51.12 | 52.21 | 56.84 | 64.51 |
| | | LWB | 48.67 | 54.53 | 60.14 | 68.48 | 47.00 | 53.04 | 58.51 | 66.89 | 44.46 | 50.60 | 55.85 | 64.28 |
| | 8000 | TC | 130.8 | 130.9 | 135.3 | 154.0 | 123.7 | 123.8 | 131.6 | 150.2 | 113.6 | 116.0 | 126.1 | 144.8 |
| | | SHC | 130.8 | 130.9 | 119.2 | 72.8 | 123.7 | 123.8 | 106.4 | 67.5 | 113.6 | 110.0 | 92.5 | 61.9 |
| | | LDB | 60.02 | 60.10 | 61.98 | 69.03 | 56.39 | 56.48 | 59.89 | 67.28 | 51.07 | 52.13 | 56.78 | 64.47 |
| | | LWB | 48.65 | 54.51 | 60.08 | 68.43 | 46.98 | 53.02 | 58.44 | 66.85 | 44.44 | 50.51 | 55.78 | 64.23 |
| | 9500 | TC | 131.4 | 131.5 | 135.8 | 154.5 | 124.2 | 124.3 | 132.1 | 151.0 | 114.0 | 116.3 | 126.7 | 145.4 |
| | | SHC | 131.4 | 131.5 | 119.4 | 73.0 | 124.2 | 124.3 | 106.6 | 67.8 | 114.0 | 110.2 | 92.5 | 62.1 |
| | | LDB | 59.93 | 60.01 | 61.95 | 69.00 | 56.29 | 56.39 | 59.86 | 67.23 | 50.96 | 52.09 | 56.70 | 64.41 |
| | | LWB | 48.61 | 54.47 | 60.05 | 68.40 | 46.93 | 52.98 | 58.41 | 66.80 | 44.39 | 50.48 | 55.72 | 64.18 |
| | | | | | | | | | | | | | | |

LEGEND

- BF — Bypass Factor
- ECT — Entering Condenser Temperature (F)
- Edb — Entering Dry Bulb (F)
- Ewb — Entering Wet Bulb (F)
- LDB — Leaving Dry Bulb (F)
- LWB — Leaving Wet Bulb (F)
- SHC — Sensible Capacity (1000 Btu/hr)
- TC — Total Capacity (1000 Btu/hr)
- kW — Compressor Motor Power Input (kilowatts)



GROSS COOLING CAPACITIES (cont)

50XCR16 (15 TONS) UNIT WITH 09XC16 (15 TONS) UNIT

| Entering Condenser Air | | BF | AIR ENTERING EVAPORATOR — 80 F Edb (F) - CFM | | | | | | | | | | | |
|------------------------|-------|-------|--|-------|-------|-------|-------|-------|-------|-------|-------|-------|-------|-------|
| | | | 7500 | | | | 6000 | | | | 4500 | | | |
| | | | Air Entering Evaporator — Ewb (F) | | | | | | | | | | | |
| ECT (F) | CFM | | 57 | 62 | 67 | 75 | 57 | 62 | 67 | 75 | 57 | 62 | 67 | 75 |
| | | | 0.26 | 0.06 | 0.05 | 0.03 | 0.39 | 0.15 | 0.08 | 0.06 | 0.48 | 0.26 | 0.11 | 0.09 |
| 55 | 6000 | TC | 203.8 | 204.2 | 216.8 | 245.4 | 191.2 | 194.5 | 210.3 | 239.1 | 173.8 | 183.8 | 200.2 | 228.8 |
| | | SHC | 203.8 | 204.1 | 172.7 | 109.9 | 191.2 | 185.0 | 154.6 | 102.7 | 173.8 | 159.1 | 135.2 | 94.9 |
| | | LDB | 55.09 | 55.18 | 59.12 | 66.76 | 50.79 | 51.89 | 56.64 | 64.53 | 44.59 | 47.79 | 52.78 | 60.98 |
| | 8000 | LWB | 46.37 | 52.47 | 57.93 | 66.44 | 44.30 | 50.43 | 55.77 | 64.34 | 41.19 | 46.96 | 52.26 | 60.92 |
| | | KW | 8.71 | 8.73 | 8.98 | 9.59 | 8.45 | 8.52 | 8.85 | 9.46 | 8.10 | 8.30 | 8.65 | 9.24 |
| | | TC | 205.2 | 205.4 | 219.2 | 249.0 | 192.4 | 196.1 | 212.5 | 242.3 | 174.8 | 184.8 | 201.7 | 231.5 |
| | 9500 | SHC | 205.2 | 205.4 | 173.6 | 111.0 | 192.4 | 185.8 | 155.5 | 103.8 | 174.8 | 159.5 | 135.8 | 95.9 |
| | | LDB | 54.92 | 55.02 | 59.01 | 66.62 | 50.60 | 51.77 | 56.50 | 64.37 | 44.40 | 47.70 | 52.67 | 60.78 |
| | | LWB | 46.29 | 52.40 | 57.82 | 66.30 | 44.21 | 50.32 | 55.64 | 64.18 | 41.09 | 46.86 | 52.13 | 60.73 |
| KW | 7.93 | 7.93 | 8.16 | 8.66 | 7.73 | 7.79 | 8.05 | 8.55 | 9.16 | 7.46 | 7.61 | 7.88 | 8.36 | |
| 75 | 6000 | TC | 190.2 | 190.4 | 199.8 | 226.8 | 179.0 | 180.0 | 194.2 | 221.2 | 163.3 | 169.9 | 185.3 | 212.2 |
| | | SHC | 190.2 | 190.4 | 165.9 | 103.7 | 179.0 | 177.2 | 148.1 | 96.6 | 163.3 | 152.4 | 128.7 | 88.8 |
| | | LDB | 56.75 | 56.85 | 59.94 | 67.50 | 52.66 | 53.06 | 57.62 | 65.45 | 46.74 | 49.14 | 54.08 | 62.18 |
| | 8000 | LWB | 47.15 | 53.17 | 58.71 | 67.15 | 45.21 | 51.39 | 56.73 | 65.23 | 42.29 | 48.25 | 53.51 | 62.09 |
| | | KW | 10.82 | 10.82 | 11.05 | 11.71 | 10.56 | 10.58 | 10.92 | 11.57 | 10.20 | 10.35 | 10.71 | 11.35 |
| | | TC | 191.6 | 191.8 | 202.1 | 229.7 | 180.1 | 181.6 | 195.9 | 223.8 | 164.1 | 171.3 | 186.8 | 214.4 |
| | 9500 | SHC | 191.6 | 191.8 | 166.8 | 104.6 | 180.1 | 178.0 | 148.7 | 97.4 | 164.1 | 153.0 | 129.3 | 89.7 |
| | | LDB | 56.58 | 56.67 | 59.83 | 67.39 | 52.48 | 52.95 | 57.53 | 65.32 | 46.57 | 49.01 | 53.96 | 62.02 |
| | | LWB | 47.07 | 53.10 | 58.60 | 67.04 | 45.12 | 51.28 | 56.63 | 65.10 | 42.20 | 48.12 | 53.39 | 61.94 |
| KW | 9.95 | 9.95 | 10.14 | 10.65 | 9.74 | 9.77 | 10.03 | 10.54 | 11.19 | 9.46 | 9.59 | 9.86 | 10.37 | |
| 95 | 6000 | TC | 175.5 | 175.6 | 181.6 | 205.9 | 165.6 | 165.8 | 176.7 | 201.3 | 151.6 | 155.4 | 169.3 | 194.0 |
| | | SHC | 175.5 | 175.6 | 158.6 | 96.9 | 165.6 | 165.8 | 141.0 | 89.9 | 151.6 | 145.3 | 122.0 | 82.4 |
| | | LDB | 58.55 | 58.65 | 60.82 | 68.31 | 54.70 | 54.80 | 58.68 | 66.45 | 49.11 | 50.56 | 55.43 | 63.47 |
| | 8000 | LWB | 47.98 | 53.91 | 59.52 | 67.93 | 46.18 | 52.31 | 57.74 | 66.20 | 43.47 | 49.58 | 54.84 | 63.35 |
| | | KW | 13.27 | 13.27 | 13.43 | 14.09 | 13.01 | 13.02 | 13.30 | 13.97 | 12.64 | 12.74 | 13.11 | 13.77 |
| | | TC | 176.7 | 176.8 | 183.6 | 208.6 | 166.5 | 166.7 | 178.4 | 203.8 | 152.3 | 156.5 | 170.4 | 195.9 |
| | 9500 | SHC | 176.7 | 176.8 | 159.4 | 97.7 | 166.5 | 166.7 | 141.8 | 90.7 | 152.3 | 145.8 | 122.4 | 83.0 |
| | | LDB | 58.41 | 58.50 | 60.72 | 68.21 | 54.56 | 54.66 | 58.57 | 66.33 | 48.97 | 50.46 | 55.34 | 63.34 |
| | | LWB | 47.91 | 53.85 | 59.44 | 67.83 | 46.12 | 52.25 | 57.65 | 66.08 | 43.41 | 49.48 | 54.74 | 63.22 |
| KW | 12.34 | 12.34 | 12.48 | 13.00 | 12.13 | 12.14 | 12.37 | 12.90 | 11.84 | 11.93 | 12.21 | 12.74 | | |
| 105 | 6000 | TC | 167.5 | 167.7 | 171.7 | 194.9 | 158.3 | 158.5 | 167.1 | 190.6 | 145.3 | 147.3 | 160.4 | 184.2 |
| | | SHC | 167.5 | 167.7 | 154.6 | 93.4 | 158.3 | 158.5 | 137.3 | 86.4 | 145.3 | 141.4 | 118.3 | 79.1 |
| | | LDB | 59.52 | 59.61 | 61.30 | 68.74 | 55.81 | 55.91 | 59.24 | 66.98 | 50.39 | 51.35 | 56.15 | 64.13 |
| | 8000 | LWB | 48.42 | 54.31 | 59.96 | 68.34 | 46.71 | 52.78 | 58.29 | 66.71 | 44.11 | 50.30 | 55.55 | 64.01 |
| | | KW | 14.60 | 14.60 | 14.72 | 15.36 | 14.35 | 14.35 | 14.59 | 15.24 | 13.99 | 14.05 | 14.41 | 15.07 |
| | | TC | 168.6 | 168.8 | 173.7 | 197.8 | 159.1 | 159.3 | 169.0 | 193.0 | 145.9 | 148.6 | 161.7 | 185.9 |
| | 9500 | SHC | 168.6 | 168.8 | 155.4 | 94.3 | 159.1 | 159.3 | 138.0 | 87.1 | 145.9 | 141.9 | 118.8 | 79.5 |
| | | LDB | 59.39 | 59.48 | 61.21 | 68.63 | 55.69 | 55.79 | 59.14 | 66.87 | 50.28 | 51.25 | 56.06 | 64.03 |
| | | LWB | 48.36 | 54.26 | 59.88 | 68.23 | 46.65 | 52.73 | 58.19 | 66.60 | 44.05 | 50.19 | 55.45 | 63.90 |
| KW | 13.67 | 13.67 | 13.78 | 14.31 | 13.46 | 13.47 | 13.68 | 14.20 | 13.18 | 13.24 | 13.52 | 14.05 | | |
| 115 | 6000 | TC | 159.0 | 159.2 | 161.6 | 183.2 | 150.6 | 150.8 | 157.3 | 179.9 | 138.6 | 139.3 | 151.3 | 173.9 |
| | | SHC | 159.0 | 159.2 | 150.4 | 89.7 | 150.6 | 150.8 | 133.5 | 83.0 | 138.6 | 137.1 | 114.6 | 75.5 |
| | | LDB | 60.56 | 60.65 | 61.82 | 69.18 | 56.99 | 57.08 | 59.83 | 67.49 | 51.77 | 52.22 | 56.90 | 64.84 |
| | 8000 | LWB | 48.89 | 54.73 | 60.41 | 68.76 | 47.26 | 53.27 | 58.85 | 67.22 | 44.78 | 51.01 | 56.28 | 64.70 |
| | | KW | 15.97 | 15.98 | 16.05 | 16.67 | 15.73 | 15.74 | 15.93 | 16.57 | 15.39 | 15.42 | 15.76 | 16.40 |
| | | TC | 160.0 | 160.2 | 163.5 | 186.0 | 151.4 | 151.5 | 159.1 | 181.7 | 139.1 | 140.4 | 152.4 | 175.4 |
| | 9500 | SHC | 160.0 | 160.2 | 151.1 | 90.6 | 151.4 | 151.5 | 134.1 | 83.5 | 139.1 | 137.6 | 115.5 | 76.4 |
| | | LDB | 60.44 | 60.53 | 61.73 | 69.08 | 56.88 | 56.97 | 59.73 | 67.42 | 51.66 | 52.11 | 56.82 | 64.75 |
| | | LWB | 48.84 | 54.68 | 60.32 | 68.66 | 47.20 | 53.22 | 58.75 | 67.13 | 44.73 | 50.91 | 56.19 | 64.60 |
| KW | 15.07 | 15.07 | 15.14 | 15.65 | 14.87 | 14.88 | 15.04 | 15.55 | 14.60 | 14.63 | 14.90 | 15.41 | | |

LEGEND

- | | | |
|--|-----------------------------|---|
| BF — Bypass Factor | EWB — Entering Wet Bulb (F) | SHC — Sensible Capacity (1000 Btu/hr) |
| ECT — Entering Condenser Temperature (F) | LDB — Leaving Dry Bulb (F) | TC — Total Capacity (1000 Btu/hr) |
| EDB — Entering Dry Bulb (F) | LWB — Leaving Wet Bulb (F) | KW — Compressor Motor Power Input (kilowatts) |

Performance data (cont)



GROSS COOLING CAPACITIES (cont)

50XCR24 (20 TONS) UNIT WITH 09XC24 (20 TONS) UNIT

| Entering Condenser Air | | BF | AIR ENTERING EVAPORATOR — 80 F Edb (F) - CFM | | | | | | | | | | | |
|------------------------|-------|-------|--|-------|-------|-------|-------|-------|-------|-------|-------|-------|-------|-------|
| ECT (F) | CFM | | 10000 | | | | 8000 | | | | 6000 | | | |
| | | | Air Entering Evaporator — Ewb (F) | | | | | | | | | | | |
| | | | 57 | 62 | 67 | 75 | 57 | 62 | 67 | 75 | 57 | 62 | 67 | 75 |
| 0.22 | 0.06 | 0.05 | 0.02 | 0.36 | 0.12 | 0.08 | 0.06 | 0.46 | 0.22 | 0.11 | 0.09 | | | |
| 55 | 8550 | TC | 283.6 | 283.9 | 303.4 | 343.6 | 266.0 | 272.2 | 294.2 | 334.0 | 241.5 | 256.8 | 279.6 | 319.2 |
| | | SHC | 283.6 | 283.9 | 235.7 | 152.1 | 266.0 | 252.8 | 211.8 | 142.4 | 241.5 | 217.7 | 185.8 | 132.0 |
| | | LDB | 54.01 | 54.11 | 58.63 | 66.25 | 49.52 | 51.19 | 56.00 | 63.92 | 43.11 | 46.94 | 51.95 | 60.18 |
| | | LWB | 45.86 | 52.02 | 57.44 | 65.97 | 43.68 | 49.79 | 55.15 | 63.77 | 40.42 | 46.12 | 51.44 | 60.16 |
| | | kW | 12.87 | 12.87 | 13.29 | 14.09 | 12.52 | 12.64 | 13.10 | 13.89 | 12.06 | 12.36 | 12.81 | 13.59 |
| | 11400 | TC | 285.9 | 286.2 | 307.0 | 348.6 | 267.7 | 274.4 | 297.3 | 338.8 | 242.7 | 258.5 | 282.1 | 323.0 |
| | | SHC | 285.9 | 286.2 | 237.3 | 153.7 | 267.7 | 253.9 | 213.1 | 144.0 | 242.7 | 218.6 | 186.9 | 133.4 |
| | | LDB | 53.79 | 53.90 | 58.48 | 66.10 | 49.33 | 51.06 | 55.85 | 63.74 | 42.92 | 46.80 | 51.79 | 59.96 |
| | | LWB | 45.75 | 51.93 | 57.31 | 65.82 | 43.58 | 49.68 | 55.01 | 63.59 | 40.33 | 45.99 | 51.28 | 59.95 |
| | | kW | 11.76 | 11.77 | 12.09 | 12.74 | 11.48 | 11.59 | 11.93 | 12.59 | 11.12 | 11.35 | 11.71 | 12.33 |
| | 12700 | TC | 286.5 | 287.3 | 308.0 | 350.2 | 268.1 | 274.9 | 298.2 | 340.1 | 243.0 | 259.0 | 282.8 | 324.1 |
| | | SHC | 286.5 | 284.4 | 237.7 | 154.3 | 268.1 | 254.3 | 213.5 | 144.5 | 243.0 | 218.9 | 187.2 | 133.8 |
| LDB | | 53.74 | 54.06 | 58.44 | 66.05 | 49.27 | 51.03 | 55.81 | 63.68 | 42.87 | 46.77 | 51.74 | 59.90 | |
| LWB | | 45.73 | 51.89 | 57.28 | 65.77 | 43.56 | 49.65 | 54.97 | 63.53 | 40.30 | 45.96 | 51.24 | 59.89 | |
| | kW | 11.48 | 11.35 | 11.62 | 12.21 | 11.22 | 11.32 | 11.66 | 12.07 | 10.88 | 11.10 | 11.43 | 11.84 | |
| 75 | 8550 | TC | 265.8 | 266.0 | 281.2 | 318.7 | 249.8 | 252.9 | 273.0 | 310.6 | 227.4 | 238.7 | 260.2 | 297.4 |
| | | SHC | 265.8 | 266.0 | 227.0 | 143.8 | 249.8 | 243.1 | 203.1 | 134.2 | 227.4 | 209.0 | 177.2 | 123.9 |
| | | LDB | 55.64 | 55.74 | 59.41 | 66.99 | 51.38 | 52.29 | 56.98 | 64.84 | 45.26 | 48.26 | 53.23 | 61.38 |
| | | LWB | 46.63 | 52.71 | 58.20 | 66.68 | 44.59 | 50.76 | 56.10 | 64.65 | 41.53 | 47.41 | 52.69 | 61.33 |
| | | kW | 16.20 | 16.21 | 16.56 | 17.44 | 15.85 | 15.91 | 16.37 | 17.24 | 15.36 | 15.60 | 16.08 | 16.94 |
| | 11400 | TC | 267.9 | 268.2 | 284.7 | 323.1 | 251.4 | 255.2 | 275.6 | 314.5 | 228.6 | 240.6 | 262.3 | 300.7 |
| | | SHC | 267.9 | 268.2 | 228.4 | 145.2 | 251.4 | 244.2 | 204.1 | 135.6 | 228.6 | 209.9 | 178.1 | 125.1 |
| | | LDB | 55.44 | 55.54 | 59.28 | 66.87 | 51.19 | 52.16 | 56.87 | 64.69 | 45.08 | 48.13 | 53.10 | 61.20 |
| | | LWB | 46.54 | 52.63 | 58.09 | 66.56 | 44.50 | 50.64 | 55.99 | 64.50 | 41.44 | 47.27 | 52.56 | 61.15 |
| | | kW | 14.84 | 14.85 | 15.14 | 15.78 | 14.57 | 14.65 | 14.97 | 15.63 | 14.21 | 14.41 | 14.75 | 15.39 |
| | 12700 | TC | 268.8 | 269.1 | 285.5 | 325.1 | 252.1 | 255.7 | 276.8 | 316.2 | 229.1 | 241.1 | 263.3 | 302.2 |
| | | SHC | 268.8 | 269.1 | 228.8 | 145.9 | 252.1 | 244.6 | 204.7 | 136.2 | 229.1 | 210.1 | 178.6 | 125.6 |
| LDB | | 55.36 | 55.46 | 59.25 | 66.80 | 51.11 | 52.12 | 56.80 | 64.62 | 44.99 | 48.09 | 53.03 | 61.12 | |
| LWB | | 46.50 | 52.59 | 58.06 | 66.50 | 44.46 | 50.61 | 55.93 | 64.44 | 41.40 | 47.24 | 52.50 | 61.08 | |
| | kW | 14.50 | 14.50 | 14.75 | 15.39 | 14.24 | 14.30 | 14.62 | 15.24 | 13.90 | 14.08 | 14.41 | 15.01 | |
| 95 | 8550 | TC | 246.1 | 246.4 | 256.8 | 290.7 | 232.0 | 231.9 | 249.7 | 284.2 | 212.0 | 219.1 | 238.8 | 273.1 |
| | | SHC | 246.1 | 246.4 | 217.3 | 134.7 | 232.0 | 231.9 | 193.6 | 125.3 | 212.0 | 199.5 | 168.1 | 115.1 |
| | | LDB | 57.44 | 57.53 | 60.29 | 67.82 | 53.42 | 53.57 | 58.05 | 65.84 | 47.62 | 49.70 | 54.61 | 62.69 |
| | | LWB | 47.47 | 53.46 | 59.04 | 67.48 | 45.58 | 51.79 | 57.13 | 65.63 | 42.73 | 48.77 | 54.04 | 62.61 |
| | | kW | 20.16 | 20.17 | 20.44 | 21.34 | 19.80 | 19.80 | 20.26 | 21.16 | 19.29 | 19.47 | 19.98 | 20.87 |
| | 11400 | TC | 247.9 | 248.2 | 259.7 | 295.0 | 233.3 | 234.0 | 251.7 | 287.7 | 212.8 | 220.7 | 240.4 | 276.1 |
| | | SHC | 247.9 | 248.2 | 218.5 | 136.1 | 233.3 | 233.9 | 194.4 | 126.5 | 212.8 | 200.2 | 168.7 | 116.1 |
| | | LDB | 57.27 | 57.37 | 60.18 | 67.70 | 53.27 | 53.33 | 57.97 | 65.71 | 47.48 | 49.59 | 54.51 | 62.53 |
| | | LWB | 47.39 | 53.39 | 58.94 | 67.36 | 45.50 | 51.69 | 57.04 | 65.50 | 42.66 | 48.66 | 53.93 | 62.46 |
| | | kW | 18.65 | 18.65 | 18.87 | 19.54 | 18.37 | 18.39 | 18.72 | 19.40 | 18.01 | 18.14 | 18.51 | 19.18 |
| | 12700 | TC | 248.9 | 249.2 | 260.6 | 297.0 | 234.2 | 234.7 | 253.0 | 289.5 | 213.5 | 221.2 | 241.5 | 277.6 |
| | | SHC | 248.9 | 249.2 | 218.9 | 136.8 | 234.2 | 233.6 | 195.0 | 127.1 | 213.5 | 200.5 | 169.3 | 116.7 |
| LDB | | 57.18 | 57.27 | 60.15 | 67.63 | 53.17 | 53.37 | 57.89 | 65.64 | 47.38 | 49.54 | 54.43 | 62.45 | |
| LWB | | 47.35 | 53.35 | 58.91 | 67.30 | 45.46 | 51.65 | 56.99 | 65.43 | 42.61 | 48.62 | 53.87 | 62.38 | |
| | kW | 18.22 | 18.23 | 18.42 | 19.06 | 17.98 | 17.99 | 18.30 | 18.93 | 17.63 | 17.76 | 18.10 | 18.72 | |
| 105 | 8550 | TC | 235.4 | 235.7 | 243.1 | 275.6 | 222.1 | 222.4 | 236.4 | 269.4 | 203.4 | 208.0 | 226.5 | 259.4 |
| | | SHC | 235.4 | 235.7 | 211.9 | 129.9 | 222.1 | 222.4 | 188.5 | 120.4 | 203.4 | 194.1 | 163.0 | 110.2 |
| | | LDB | 58.42 | 58.51 | 60.78 | 68.26 | 54.55 | 54.65 | 58.63 | 66.39 | 48.93 | 50.50 | 55.37 | 63.41 |
| | | LWB | 47.92 | 53.86 | 59.50 | 67.90 | 46.11 | 52.25 | 57.71 | 66.16 | 43.39 | 49.53 | 54.79 | 63.32 |
| | | kW | 22.36 | 22.36 | 22.57 | 23.47 | 21.99 | 22.00 | 22.39 | 23.30 | 21.48 | 21.63 | 22.13 | 23.03 |
| | 11400 | TC | 237.0 | 237.2 | 246.4 | 280.4 | 223.3 | 223.6 | 239.3 | 273.2 | 204.1 | 209.9 | 228.5 | 262.6 |
| | | SHC | 237.0 | 237.2 | 213.1 | 131.4 | 223.3 | 223.6 | 189.5 | 121.6 | 204.1 | 195.0 | 163.7 | 111.3 |
| | | LDB | 58.27 | 58.37 | 60.67 | 68.12 | 54.42 | 54.52 | 58.51 | 66.26 | 48.81 | 50.38 | 55.26 | 63.25 |
| | | LWB | 47.85 | 53.80 | 59.39 | 67.77 | 46.05 | 52.19 | 57.59 | 66.03 | 43.33 | 49.39 | 54.67 | 63.15 |
| | | kW | 20.81 | 20.81 | 20.99 | 21.67 | 20.54 | 20.54 | 20.85 | 21.52 | 20.15 | 20.26 | 20.64 | 21.31 |
| | 12700 | TC | 238.1 | 238.3 | 247.2 | 281.7 | 224.2 | 224.5 | 240.1 | 274.9 | 204.8 | 210.4 | 229.7 | 264.1 |
| | | SHC | 238.1 | 238.3 | 213.6 | 131.8 | 224.2 | 224.5 | 189.9 | 122.2 | 204.8 | 195.2 | 164.3 | 111.9 |
| LDB | | 58.17 | 58.26 | 60.63 | 68.08 | 54.31 | 54.41 | 58.47 | 66.18 | 48.71 | 50.34 | 55.18 | 63.16 | |
| LWB | | 47.81 | 53.76 | 59.36 | 67.73 | 46.00 | 52.15 | 57.55 | 65.96 | 43.28 | 49.36 | 54.60 | 63.07 | |
| | kW | 20.36 | 20.36 | 20.52 | 21.15 | 20.11 | 20.11 | 20.40 | 21.03 | 19.76 | 19.86 | 20.21 | 20.83 | |
| 115 | 8550 | TC | 223.9 | 224.1 | 229.1 | 259.8 | 211.6 | 211.8 | 223.0 | 254.3 | 194.2 | 196.6 | 213.9 | 245.2 |
| | | SHC | 223.9 | 224.1 | 206.2 | 124.8 | 211.6 | 211.8 | 183.2 | 115.4 | 194.2 | 188.6 | 157.8 | 105.3 |
| | | LDB | 59.48 | 59.56 | 61.30 | 68.71 | 55.76 | 55.85 | 59.23 | 66.95 | 50.33 | 51.34 | 56.15 | 64.14 |
| | | LWB | 48.40 | 54.29 | 59.96 | 68.34 | 46.68 | 52.76 | 58.29 | 66.71 | 44.08 | 50.29 | 55.55 | 64.03 |
| | | kW | 24.67 | 24.68 | 24.83 | 25.73 | 24.32 | 24.33 | 24.66 | 25.58 | 23.80 | 23.90 | 24.40 | 25.31 |
| | 11400 | TC | 225.3 | 225.5 | 232.2 | 264.3 | 212.6 | 212.9 | 225.8 | 257.7 | 194.8 | 198.5 | 215.8 | 248.3 |
| | | SHC | 225.3 | 225.5 | 207.4 | 126.2 | 212.6 | 212.9 | 184.2 | 116.5 | 194.8 | 189.3 | 158.5 | 106.3 |
| | | LDB | 59.35 | 59.43 | 61.19 | 68.58 | 55.64 | 55.74 | 59.12 | 66.83 | 50.24 | 51.24 | 56.05 | 63.99 |
| | | LWB | 48.34 | 54.24 | 59.86 | 68.22 | 46.63 | 52.71 | 58.17 | 66.59 | 44.03 | 50.16 | 55.44 | 63.88 |
| | | kW | 23.10 | 23.10 | 23.23 | 23.91 | 22.83 | 22.84 | 23.10 | 23.78 | 22.46 | 22.52 | 22.90 | 23.58 |
| | 12700 | TC | 226.4 | 226.7 | 233.1 | 265.6 | 213.6 | 213.9 | 226.5 | 259.6 | 195.6 | 199.0 | 217.0 | 249.9 |
| | | SHC | 226.4 | 226.7 | 207.8 | 126.7 | 213.6 | 213.9 | 184.5 | 117.2 | 195.6 | 189.6 | 159.1 | 106.9 |
| LDB | | 59.24 | 59.33 | 61.15 | 68.54 | 55.52 | 55.62 | 59.08 | 66.75 | 50.11 | 51.19 | 55.97 | 63.90 | |
| LWB | | 48.30 | 54.20 | 59.83 | 68.18 | 46.57 | 52.66 | 58.14 | 66.52 | 43.97 | 50.13 | 55.37 | 63.80 | |
| | kW | 22.64 | 22.64 | 22.76 | 23.38 | 22.40 | 22.40 | 22.64 | 23.26 | 22.06 | 22.12 | 22.47 | 23.09 | |

LEGEND

- BF — Bypass Factor
- ECT — Entering Condenser Temperature (F)
- EDB — Entering Dry Bulb (F)
- EWB — Entering Wet Bulb (F)
- LDB — Leaving Dry Bulb (F)
- LWB — Leaving Wet Bulb (F)
- SHC — Sensible Capacity (1000 Btu/hr)
- TC — Total Capacity (1000 Btu/hr)
- kW — Compressor Motor Power Input (kilowatts)



CONDENSER FAN PERFORMANCE

09XC06 (5 Tons)

| CFM | ESP (in. wg) | | | | | | | | | | | |
|------|--------------|------|------|------|------|------|------|------|------|------|------|------|
| | 0.00 | | 0.10 | | 0.20 | | 0.30 | | 0.40 | | 0.50 | |
| | Rpm | Bhp | Rpm | Bhp | Rpm | Bhp | Rpm | Bhp | Rpm | Bhp | Rpm | Bhp |
| 1800 | 594 | 0.19 | 594 | 0.19 | 594 | 0.19 | 676 | 0.25 | 755 | 0.33 | 828 | 0.42 |
| 1900 | 588 | 0.19 | 588 | 0.19 | 598 | 0.20 | 686 | 0.27 | 764 | 0.35 | 836 | 0.44 |
| 2000 | 582 | 0.19 | 582 | 0.19 | 610 | 0.21 | 696 | 0.29 | 773 | 0.37 | 844 | 0.46 |
| 2100 | 576 | 0.19 | 576 | 0.19 | 623 | 0.23 | 707 | 0.31 | 783 | 0.40 | 852 | 0.49 |
| 2200 | 570 | 0.20 | 570 | 0.20 | 636 | 0.25 | 718 | 0.33 | 793 | 0.42 | 861 | 0.51 |
| 2300 | 564 | 0.20 | 564 | 0.20 | 649 | 0.27 | 730 | 0.36 | 803 | 0.44 | 870 | 0.54 |
| 2400 | 558 | 0.20 | 573 | 0.22 | 662 | 0.29 | 742 | 0.38 | 814 | 0.47 | 880 | 0.57 |
| 2500 | 552 | 0.21 | 589 | 0.24 | 676 | 0.32 | 754 | 0.41 | 825 | 0.50 | 890 | 0.60 |
| 2600 | 546 | 0.21 | 605 | 0.26 | 690 | 0.34 | 766 | 0.43 | 836 | 0.53 | 901 | 0.63 |
| 2600 | 540 | 0.21 | 622 | 0.28 | 704 | 0.37 | 779 | 0.46 | 848 | 0.56 | 911 | 0.66 |
| 2800 | 550 | 0.23 | 638 | 0.31 | 719 | 0.40 | 792 | 0.49 | 860 | 0.59 | 923 | 0.70 |
| 2900 | 570 | 0.26 | 655 | 0.34 | 734 | 0.43 | 806 | 0.53 | 872 | 0.63 | 934 | 0.74 |
| 3000 | 590 | 0.29 | 672 | 0.37 | 749 | 0.46 | 819 | 0.56 | 885 | 0.67 | 946 | 0.78 |

09XC06 (5 Tons) (cont)

| CFM | ESP (in. wg) | | | | | | | | | | | |
|------|--------------|------|------|------|------|------|------|------|------|------|------|------|
| | 0.60 | | 0.70 | | 0.80 | | 0.90 | | 1.00 | | 1.10 | |
| | Rpm | Bhp | Rpm | Bhp | Rpm | Bhp | Rpm | Bhp | Rpm | Bhp | Rpm | Bhp |
| 1800 | 896 | 0.51 | 960 | 0.61 | 1020 | 0.72 | — | — | — | — | — | — |
| 1900 | 902 | 0.54 | 965 | 0.64 | 1025 | 0.74 | 1082 | 0.86 | — | — | — | — |
| 2000 | 909 | 0.56 | 971 | 0.66 | 1030 | 0.77 | 1086 | 0.88 | 1140 | 1.00 | — | — |
| 2100 | 917 | 0.58 | 978 | 0.69 | 1036 | 0.80 | 1091 | 0.91 | 1145 | 1.03 | 1196 | 1.16 |
| 2200 | 925 | 0.61 | 985 | 0.72 | 1042 | 0.83 | 1097 | 0.94 | 1150 | 1.06 | 1201 | 1.19 |
| 2300 | 933 | 0.64 | 993 | 0.75 | 1049 | 0.86 | 1103 | 0.98 | 1155 | 1.10 | 1206 | 1.22 |
| 2400 | 942 | 0.67 | 1001 | 0.78 | 1057 | 0.89 | 1110 | 1.01 | 1162 | 1.13 | 1211 | 1.26 |
| 2500 | 951 | 0.70 | 1009 | 0.81 | 1065 | 0.93 | 1117 | 1.05 | 1168 | 1.17 | 1217 | 1.30 |
| 2600 | 961 | 0.74 | 1018 | 0.85 | 1073 | 0.96 | 1125 | 1.09 | 1175 | 1.21 | 1224 | 1.34 |
| 2700 | 971 | 0.77 | 1028 | 0.89 | 1081 | 1.00 | 1133 | 1.13 | 1183 | 1.25 | 1231 | 1.39 |
| 2800 | 982 | 0.81 | 1037 | 0.93 | 1090 | 1.05 | 1141 | 1.17 | 1191 | 1.30 | 1238 | 1.43 |
| 2900 | 992 | 0.85 | 1047 | 0.97 | 1100 | 1.09 | 1150 | 1.21 | 1199 | 1.34 | 1246 | 1.48 |
| 3000 | 1003 | 0.89 | 1058 | 1.01 | 1110 | 1.13 | 1159 | 1.26 | 1207 | 1.39 | — | — |

LEGEND

Bhp — Brake Horsepower
ESP — External Static Pressure

NOTES:

- Units are available with several motor hp options. Refer to Physical Data table.
- Static pressure losses for any options or accessories must be applied to external static pressure before entering the fan performance table.
- Interpolation is permitted; extrapolation is not.
- Fan performance is based on unit casing, and dry DX (direct expansion) coil losses at sea level.

Performance data (cont)



CONDENSER FAN PERFORMANCE (cont)

| 09XC08 (7½ TONS) | | | | | | | | | | | | | | | | |
|------------------|--------------|------|------|------|------|------|------|------|------|------|------|------|------|------|------|------|
| CFM | ESP (in. wg) | | | | | | | | | | | | | | | |
| | 0.00 | | 0.10 | | 0.20 | | 0.30 | | 0.40 | | 0.50 | | 0.60 | | 0.70 | |
| | Rpm | Bhp | Rpm | Bhp | Rpm | Bhp | Rpm | Bhp | Rpm | Bhp | Rpm | Bhp | Rpm | Bhp | Rpm | Bhp |
| 2500 | 594 | 0.25 | 594 | 0.25 | 662 | 0.32 | 738 | 0.41 | 807 | 0.50 | 872 | 0.60 | 932 | 0.70 | 988 | 0.81 |
| 2650 | 588 | 0.26 | 600 | 0.27 | 682 | 0.36 | 757 | 0.45 | 824 | 0.55 | 887 | 0.65 | 946 | 0.75 | 1001 | 0.87 |
| 2800 | 582 | 0.27 | 625 | 0.31 | 704 | 0.40 | 776 | 0.49 | 842 | 0.59 | 903 | 0.70 | 961 | 0.81 | 1016 | 0.93 |
| 2950 | 576 | 0.28 | 650 | 0.35 | 726 | 0.45 | 795 | 0.54 | 860 | 0.65 | 920 | 0.76 | 977 | 0.87 | 1030 | 0.99 |
| 3100 | 597 | 0.31 | 675 | 0.40 | 748 | 0.50 | 816 | 0.60 | 879 | 0.71 | 938 | 0.82 | 993 | 0.94 | 1046 | 1.06 |
| 3250 | 625 | 0.36 | 700 | 0.45 | 771 | 0.55 | 836 | 0.66 | 898 | 0.77 | 956 | 0.88 | 1010 | 1.00 | 1062 | 1.13 |
| 3400 | 654 | 0.42 | 726 | 0.51 | 794 | 0.61 | 858 | 0.72 | 918 | 0.83 | 974 | 0.95 | 1027 | 1.08 | 1078 | 1.21 |
| 3550 | 683 | 0.47 | 752 | 0.57 | 818 | 0.68 | 879 | 0.79 | 938 | 0.91 | 993 | 1.03 | 1045 | 1.16 | 1095 | 1.29 |
| 3700 | 712 | 0.54 | 778 | 0.64 | 842 | 0.75 | 901 | 0.86 | 958 | 0.98 | 1012 | 1.11 | 1064 | 1.24 | 1113 | 1.37 |
| 3850 | 741 | 0.60 | 805 | 0.71 | 866 | 0.82 | 924 | 0.94 | 979 | 1.06 | 1032 | 1.19 | 1083 | 1.33 | 1131 | 1.47 |
| 4000 | 770 | 0.68 | 831 | 0.79 | 890 | 0.90 | 947 | 1.02 | 1001 | 1.15 | 1053 | 1.29 | 1102 | 1.42 | 1150 | 1.56 |
| 4150 | 799 | 0.75 | 858 | 0.87 | 915 | 0.99 | 970 | 1.11 | 1023 | 1.25 | 1073 | 1.38 | 1122 | 1.52 | 1168 | 1.67 |
| 4300 | 828 | 0.84 | 885 | 0.96 | 940 | 1.08 | 994 | 1.21 | 1045 | 1.34 | 1094 | 1.49 | 1142 | 1.63 | 1188 | 1.78 |
| 4450 | 856 | 0.93 | 912 | 1.05 | 966 | 1.18 | 1017 | 1.31 | 1068 | 1.45 | 1116 | 1.59 | 1162 | 1.74 | 1207 | 1.89 |
| 4600 | 885 | 1.03 | 939 | 1.15 | 991 | 1.28 | 1042 | 1.42 | 1090 | 1.56 | 1138 | 1.71 | 1183 | 1.86 | — | — |

| 09XC08 (7½ TONS) (cont) | | | | | | | | | | | | | | | | |
|-------------------------|--------------|------|------|------|------|------|------|------|------|------|------|------|------|------|--|--|
| CFM | ESP (in. wg) | | | | | | | | | | | | | | | |
| | 0.80 | | 0.90 | | 1.00 | | 1.10 | | 1.20 | | 1.30 | | 1.40 | | | |
| | Rpm | Bhp | Rpm | Bhp | Rpm | Bhp | Rpm | Bhp | Rpm | Bhp | Rpm | Bhp | Rpm | Bhp | | |
| 2500 | 1042 | 0.93 | 1094 | 1.05 | 1144 | 1.17 | 1192 | 1.30 | 1238 | 1.43 | 1283 | 1.57 | 1327 | 1.72 | | |
| 2650 | 1055 | 0.98 | 1105 | 1.11 | 1154 | 1.23 | 1201 | 1.36 | 1247 | 1.50 | 1291 | 1.64 | 1334 | 1.78 | | |
| 2800 | 1068 | 1.05 | 1117 | 1.17 | 1166 | 1.30 | 1212 | 1.43 | 1257 | 1.57 | 1301 | 1.71 | 1343 | 1.86 | | |
| 2950 | 1081 | 1.11 | 1131 | 1.24 | 1178 | 1.37 | 1224 | 1.50 | 1268 | 1.64 | 1311 | 1.79 | 1353 | 1.94 | | |
| 3100 | 1096 | 1.18 | 1144 | 1.31 | 1191 | 1.44 | 1236 | 1.58 | 1279 | 1.72 | 1322 | 1.87 | — | — | | |
| 3250 | 1111 | 1.26 | 1159 | 1.39 | 1205 | 1.53 | 1249 | 1.67 | 1292 | 1.81 | 1334 | 1.96 | — | — | | |
| 3400 | 1127 | 1.34 | 1174 | 1.47 | 1219 | 1.61 | 1263 | 1.75 | 1305 | 1.90 | — | — | — | — | | |
| 3550 | 1143 | 1.42 | 1189 | 1.56 | 1234 | 1.70 | 1277 | 1.85 | 1319 | 2.00 | — | — | — | — | | |
| 3700 | 1160 | 1.51 | 1206 | 1.65 | 1249 | 1.80 | 1292 | 1.95 | — | — | — | — | — | — | | |
| 3850 | 1178 | 1.61 | 1222 | 1.75 | 1265 | 1.90 | — | — | — | — | — | — | — | — | | |
| 4000 | 1195 | 1.71 | 1239 | 1.86 | — | — | — | — | — | — | — | — | — | — | | |
| 4150 | 1213 | 1.82 | 1257 | 1.97 | — | — | — | — | — | — | — | — | — | — | | |
| 4300 | 1232 | 1.93 | — | — | — | — | — | — | — | — | — | — | — | — | | |
| 4450 | — | — | — | — | — | — | — | — | — | — | — | — | — | — | | |
| 4600 | — | — | — | — | — | — | — | — | — | — | — | — | — | — | | |

LEGEND

Bhp — Brake Horsepower
ESP — External Static Pressure

NOTES:

- Units are available with several motor hp options. Refer to Physical Data table.
- Static pressure losses for any options or accessories must be applied to external static pressure before entering the fan performance table.
- Interpolation is permitted; extrapolation is not.
- Fan performance is based on unit casing, and dry DX (direct expansion) coil losses at sea level.



CONDENSER FAN PERFORMANCE (cont)

| 09XC12 (10 Tons) | | | | | | | | | | | | | | | | |
|-------------------------|---------------------|------------|-------------|------------|-------------|------------|-------------|------------|-------------|------------|-------------|------------|-------------|------------|-------------|------------|
| CFM | ESP (in. wg) | | | | | | | | | | | | | | | |
| | 0.00 | | 0.10 | | 0.20 | | 0.30 | | 0.40 | | 0.50 | | 0.60 | | 0.70 | |
| | Rpm | Bhp | Rpm | Bhp | Rpm | Bhp | Rpm | Bhp | Rpm | Bhp | Rpm | Bhp | Rpm | Bhp | Rpm | Bhp |
| 4100 | 427 | 0.58 | 476 | 0.70 | 526 | 0.83 | 570 | 0.96 | 610 | 1.09 | 648 | 1.23 | 684 | 1.36 | 720 | 1.51 |
| 4300 | 448 | 0.67 | 494 | 0.79 | 543 | 0.93 | 586 | 1.07 | 625 | 1.21 | 662 | 1.34 | 697 | 1.49 | 731 | 1.63 |
| 4500 | 468 | 0.76 | 512 | 0.89 | 559 | 1.04 | 602 | 1.18 | 640 | 1.33 | 676 | 1.47 | 710 | 1.62 | 744 | 1.77 |
| 4700 | 489 | 0.87 | 531 | 1.00 | 576 | 1.15 | 618 | 1.31 | 655 | 1.46 | 691 | 1.61 | 724 | 1.76 | 757 | 1.91 |
| 4900 | 510 | 0.98 | 550 | 1.12 | 594 | 1.28 | 634 | 1.44 | 671 | 1.60 | 706 | 1.75 | 738 | 1.91 | 770 | 2.07 |
| 5100 | 531 | 1.11 | 569 | 1.25 | 611 | 1.41 | 651 | 1.58 | 687 | 1.75 | 721 | 1.91 | 753 | 2.07 | 784 | 2.24 |
| 5300 | 552 | 1.25 | 588 | 1.39 | 628 | 1.56 | 667 | 1.74 | 703 | 1.91 | 736 | 2.08 | 768 | 2.24 | 798 | 2.41 |
| 5500 | 572 | 1.39 | 607 | 1.54 | 646 | 1.71 | 684 | 1.90 | 719 | 2.08 | 752 | 2.25 | 783 | 2.43 | 813 | 2.60 |
| 5700 | 593 | 1.55 | 626 | 1.70 | 664 | 1.88 | 701 | 2.07 | 736 | 2.26 | 768 | 2.44 | 798 | 2.62 | 828 | 2.80 |
| 5900 | 614 | 1.72 | 646 | 1.87 | 682 | 2.06 | 718 | 2.25 | 752 | 2.45 | 784 | 2.64 | 814 | 2.83 | 843 | 3.01 |
| 6100 | 635 | 1.90 | 665 | 2.05 | 700 | 2.25 | 735 | 2.45 | 769 | 2.65 | 800 | 2.85 | 830 | 3.04 | 858 | 3.24 |
| 6300 | 656 | 2.09 | 685 | 2.26 | 719 | 2.45 | 753 | 2.66 | 786 | 2.87 | 817 | 3.07 | 846 | 3.27 | 874 | 3.47 |
| 6500 | 676 | 2.30 | 705 | 2.46 | 737 | 2.66 | 770 | 2.88 | 803 | 3.09 | 833 | 3.30 | 862 | 3.51 | 889 | 3.72 |
| 6700 | 697 | 2.52 | 725 | 2.69 | 756 | 2.89 | 788 | 3.11 | 820 | 3.33 | 850 | 3.55 | 878 | 3.77 | 905 | 3.98 |
| 6900 | 718 | 2.75 | 744 | 2.92 | 774 | 3.13 | 806 | 3.35 | 837 | 3.58 | 866 | 3.81 | 894 | 4.03 | 921 | 4.26 |

09XC12 (10 Tons) (cont)

| CFM | ESP (in. wg) | | | | | | | | | | | |
|------------|---------------------|------------|-------------|------------|-------------|------------|-------------|------------|-------------|------------|-------------|------------|
| | 0.80 | | 0.90 | | 1.00 | | 1.10 | | 1.20 | | 1.30 | |
| | Rpm | Bhp | Rpm | Bhp | Rpm | Bhp | Rpm | Bhp | Rpm | Bhp | Rpm | Bhp |
| 4100 | — | — | — | — | — | — | — | — | — | — | — | — |
| 4300 | 765 | 1.79 | — | — | — | — | — | — | — | — | — | — |
| 4500 | 776 | 1.92 | — | — | — | — | — | — | — | — | — | — |
| 4700 | 788 | 2.07 | 819 | 2.24 | — | — | — | — | — | — | — | — |
| 4900 | 801 | 2.23 | 831 | 2.40 | 860 | 2.57 | — | — | — | — | — | — |
| 5100 | 814 | 2.40 | 843 | 2.58 | 872 | 2.75 | 900 | 2.93 | — | — | — | — |
| 5300 | 827 | 2.59 | 856 | 2.76 | 884 | 2.94 | 912 | 3.13 | 939 | 3.31 | — | — |
| 5500 | 841 | 2.78 | 869 | 2.96 | 896 | 3.14 | 923 | 3.33 | 950 | 3.52 | 976 | 3.72 |
| 5700 | 856 | 2.99 | 883 | 3.17 | 910 | 3.36 | 936 | 3.55 | 962 | 3.74 | 987 | 3.94 |
| 5900 | 870 | 3.20 | 897 | 3.39 | 923 | 3.58 | 949 | 3.78 | 974 | 3.98 | 999 | 4.18 |
| 6100 | 885 | 3.43 | 911 | 3.63 | 937 | 3.82 | 962 | 4.02 | 987 | 4.23 | 1011 | 4.43 |
| 6300 | 900 | 3.67 | 926 | 3.87 | 951 | 4.08 | 976 | 4.28 | 1000 | 4.49 | 1024 | 4.70 |
| 6500 | 916 | 3.93 | 941 | 4.14 | 966 | 4.34 | 990 | 4.55 | 1014 | 4.76 | 1037 | 4.98 |
| 6700 | 931 | 4.20 | 956 | 4.41 | 981 | 4.62 | 1004 | 4.84 | — | — | — | — |
| 6900 | 947 | 4.48 | 972 | 4.70 | 996 | 4.91 | — | — | — | — | — | — |

LEGEND

Bhp — Brake Horsepower
ESP — External Static Pressure

NOTES:

- Units are available with several motor hp options. Refer to Physical Data table.
- Static pressure losses for any options or accessories must be applied to external static pressure before entering the fan performance table.
- Interpolation is permitted; extrapolation is not.
- Fan performance is based on unit casing, and dry DX (direct expansion) coil losses at sea level.

Performance data (cont)



CONDENSER FAN PERFORMANCE (cont)

| 09XC14 (12 Tons) | | | | | | | | | | | | | | | | |
|------------------|--------------|------|------|------|------|------|------|------|------|------|------|------|------|------|------|------|
| CFM | ESP (in. wg) | | | | | | | | | | | | | | | |
| | 0.00 | | 0.10 | | 0.20 | | 0.30 | | 0.40 | | 0.50 | | 0.60 | | 0.70 | |
| | Rpm | Bhp | Rpm | Bhp | Rpm | Bhp | Rpm | Bhp | Rpm | Bhp | Rpm | Bhp | Rpm | Bhp | Rpm | Bhp |
| 6000 | 494 | 1.50 | 494 | 1.50 | 494 | 1.50 | 494 | 1.50 | 494 | 1.50 | 521 | 1.68 | 554 | 1.93 | 586 | 2.18 |
| 6250 | 488 | 1.52 | 488 | 1.52 | 488 | 1.52 | 488 | 1.52 | 494 | 1.56 | 528 | 1.80 | 561 | 2.05 | 592 | 2.30 |
| 6500 | 482 | 1.53 | 482 | 1.53 | 482 | 1.53 | 482 | 1.53 | 502 | 1.67 | 536 | 1.92 | 568 | 2.17 | 599 | 2.44 |
| 6750 | 476 | 1.55 | 476 | 1.55 | 476 | 1.55 | 477 | 1.56 | 511 | 1.79 | 544 | 2.05 | 576 | 2.31 | 606 | 2.58 |
| 7000 | 470 | 1.56 | 470 | 1.56 | 470 | 1.56 | 488 | 1.68 | 520 | 1.93 | 552 | 2.18 | 583 | 2.45 | 613 | 2.73 |
| 7250 | 464 | 1.58 | 464 | 1.58 | 466 | 1.59 | 498 | 1.82 | 530 | 2.07 | 561 | 2.33 | 591 | 2.60 | 621 | 2.88 |
| 7500 | 458 | 1.59 | 458 | 1.59 | 477 | 1.73 | 509 | 1.96 | 540 | 2.21 | 570 | 2.48 | 600 | 2.76 | 628 | 3.04 |
| 7750 | 452 | 1.61 | 459 | 1.66 | 489 | 1.88 | 519 | 2.12 | 549 | 2.37 | 579 | 2.64 | 608 | 2.92 | 636 | 3.22 |
| 8000 | 446 | 1.62 | 472 | 1.81 | 501 | 2.04 | 530 | 2.28 | 560 | 2.54 | 588 | 2.81 | 617 | 3.10 | 644 | 3.40 |
| 8250 | 458 | 1.77 | 485 | 1.97 | 513 | 2.20 | 542 | 2.45 | 570 | 2.71 | 598 | 2.99 | 626 | 3.28 | 653 | 3.59 |
| 8500 | 472 | 1.93 | 498 | 2.14 | 526 | 2.38 | 553 | 2.63 | 580 | 2.90 | 608 | 3.18 | 635 | 3.48 | 661 | 3.79 |
| 8750 | 486 | 2.11 | 512 | 2.33 | 538 | 2.56 | 564 | 2.82 | 591 | 3.09 | 618 | 3.38 | 644 | 3.68 | 670 | 4.00 |
| 9000 | 500 | 2.29 | 525 | 2.52 | 550 | 2.76 | 576 | 3.02 | 602 | 3.30 | 628 | 3.59 | 654 | 3.90 | 679 | 4.22 |
| 9250 | 514 | 2.49 | 538 | 2.72 | 563 | 2.97 | 588 | 3.23 | 613 | 3.52 | 638 | 3.81 | 663 | 4.13 | 688 | 4.45 |
| 9500 | 528 | 2.70 | 551 | 2.93 | 575 | 3.19 | 600 | 3.46 | 624 | 3.74 | 649 | 4.05 | 673 | 4.36 | 697 | 4.69 |

| 09XC14 (12 Tons) (cont) | | | | | | | | | | | | | | |
|-------------------------|--------------|------|------|------|------|------|------|------|------|------|------|------|------|------|
| CFM | ESP (in. wg) | | | | | | | | | | | | | |
| | 0.80 | | 0.90 | | 1.00 | | 1.10 | | 1.20 | | 1.30 | | 1.40 | |
| | Rpm | Bhp | Rpm | Bhp | Rpm | Bhp | Rpm | Bhp | Rpm | Bhp | Rpm | Bhp | Rpm | Bhp |
| 6000 | 616 | 2.43 | 644 | 2.69 | 671 | 2.96 | 697 | 3.23 | 722 | 3.50 | 746 | 3.78 | 768 | 4.06 |
| 6250 | 622 | 2.57 | 650 | 2.84 | 677 | 3.11 | 703 | 3.39 | 728 | 3.67 | 751 | 3.95 | 774 | 4.24 |
| 6500 | 628 | 2.71 | 656 | 2.98 | 683 | 3.27 | 709 | 3.55 | 734 | 3.84 | 757 | 4.13 | 780 | 4.43 |
| 6750 | 635 | 2.86 | 663 | 3.14 | 689 | 3.43 | 715 | 3.72 | 739 | 4.02 | 763 | 4.32 | 786 | 4.62 |
| 7000 | 642 | 3.01 | 669 | 3.30 | 696 | 3.60 | 721 | 3.90 | 745 | 4.20 | 769 | 4.51 | 792 | 4.82 |
| 7250 | 649 | 3.17 | 676 | 3.47 | 702 | 3.77 | 727 | 4.08 | 752 | 4.39 | 775 | 4.71 | — | — |
| 7500 | 656 | 3.34 | 683 | 3.65 | 709 | 3.96 | 734 | 4.27 | 758 | 4.59 | 781 | 4.91 | — | — |
| 7750 | 663 | 3.52 | 690 | 3.83 | 715 | 4.15 | 740 | 4.47 | 764 | 4.80 | — | — | — | — |
| 8000 | 671 | 3.71 | 697 | 4.02 | 722 | 4.35 | 747 | 4.67 | — | — | — | — | — | — |
| 8250 | 679 | 3.90 | 705 | 4.22 | 730 | 4.55 | 754 | 4.89 | — | — | — | — | — | — |
| 8500 | 687 | 4.11 | 712 | 4.44 | 737 | 4.77 | — | — | — | — | — | — | — | — |
| 8750 | 695 | 4.32 | 720 | 4.66 | 744 | 5.00 | — | — | — | — | — | — | — | — |
| 9000 | 704 | 455 | 728 | 489 | — | — | — | — | — | — | — | — | — | — |
| 9250 | 712 | 498 | — | — | — | — | — | — | — | — | — | — | — | — |
| 9500 | — | — | — | — | — | — | — | — | — | — | — | — | — | — |

LEGEND

Bhp — Brake Horsepower
ESP — External Static Pressure

NOTES:

- Units are available with several motor hp options. Refer to Physical Data table.
- Static pressure losses for any options or accessories must be applied to external static pressure before entering the fan performance table.
- Interpolation is permitted; extrapolation is not.
- Fan performance is based on unit casing, and dry DX (direct expansion) coil losses at sea level.



CONDENSER FAN PERFORMANCE (cont)

09XC16 (15 Tons)

| CFM | ESP (in. wg) | | | | | | | | | | | | | | | |
|------|--------------|------|------|------|------|------|------|------|------|------|------|------|------|------|------|------|
| | 0.00 | | 0.10 | | 0.20 | | 0.30 | | 0.40 | | 0.50 | | 0.60 | | 0.70 | |
| | Rpm | Bhp | Rpm | Bhp | Rpm | Bhp | Rpm | Bhp | Rpm | Bhp | Rpm | Bhp | Rpm | Bhp | Rpm | Bhp |
| 6250 | 494 | 1.56 | 494 | 1.56 | 494 | 1.56 | 494 | 1.56 | 494 | 1.56 | 528 | 1.80 | 561 | 2.05 | 592 | 2.30 |
| 6500 | 488 | 1.57 | 488 | 1.57 | 488 | 1.57 | 488 | 1.57 | 502 | 1.67 | 536 | 1.92 | 568 | 2.17 | 599 | 2.44 |
| 6750 | 482 | 1.59 | 482 | 1.59 | 482 | 1.59 | 482 | 1.59 | 511 | 1.79 | 544 | 2.05 | 576 | 2.31 | 606 | 2.58 |
| 7000 | 476 | 1.61 | 476 | 1.61 | 476 | 1.61 | 488 | 1.68 | 520 | 1.93 | 552 | 2.18 | 583 | 2.45 | 613 | 2.73 |
| 7250 | 470 | 1.62 | 470 | 1.62 | 470 | 1.62 | 498 | 1.82 | 530 | 2.07 | 561 | 2.33 | 591 | 2.60 | 621 | 2.88 |
| 7500 | 464 | 1.64 | 464 | 1.64 | 477 | 1.73 | 509 | 1.96 | 540 | 2.21 | 570 | 2.48 | 600 | 2.76 | 628 | 3.04 |
| 7750 | 458 | 1.65 | 459 | 1.66 | 489 | 1.88 | 519 | 2.12 | 549 | 2.37 | 579 | 2.64 | 608 | 2.92 | 636 | 3.22 |
| 8000 | 452 | 1.67 | 472 | 1.81 | 501 | 2.04 | 530 | 2.28 | 560 | 2.54 | 588 | 2.81 | 617 | 3.10 | 644 | 3.40 |
| 8250 | 458 | 1.77 | 485 | 1.97 | 513 | 2.20 | 542 | 2.45 | 570 | 2.71 | 598 | 2.99 | 626 | 3.28 | 653 | 3.59 |
| 8500 | 472 | 1.93 | 498 | 2.14 | 526 | 2.38 | 553 | 2.63 | 580 | 2.90 | 608 | 3.18 | 635 | 3.48 | 661 | 3.79 |
| 8750 | 486 | 2.11 | 512 | 2.33 | 538 | 2.56 | 564 | 2.82 | 591 | 3.09 | 618 | 3.38 | 644 | 3.68 | 670 | 4.00 |
| 9000 | 500 | 2.29 | 525 | 2.52 | 550 | 2.76 | 576 | 3.02 | 602 | 3.30 | 628 | 3.59 | 654 | 3.90 | 679 | 4.22 |
| 9250 | 514 | 2.49 | 538 | 2.72 | 563 | 2.97 | 588 | 3.23 | 613 | 3.52 | 638 | 3.81 | 663 | 4.13 | 688 | 4.45 |
| 9500 | 528 | 2.70 | 551 | 2.93 | 575 | 3.19 | 600 | 3.46 | 624 | 3.74 | 649 | 4.05 | 673 | 4.36 | 697 | 4.69 |
| 9750 | 542 | 2.92 | 564 | 3.16 | 588 | 3.42 | 612 | 3.69 | 635 | 3.98 | 659 | 4.29 | 683 | 4.61 | 707 | 4.94 |

09XC16 (15 Tons) (cont)

| CFM | ESP (in. wg) | | | | | | | | | | | | | |
|------|--------------|------|------|------|------|------|------|------|------|------|------|------|------|------|
| | 0.80 | | 0.90 | | 1.00 | | 1.10 | | 1.20 | | 1.30 | | 1.40 | |
| | Rpm | Bhp | Rpm | Bhp | Rpm | Bhp | Rpm | Bhp | Rpm | Bhp | Rpm | Bhp | Rpm | Bhp |
| 6250 | 622 | 2.57 | 650 | 2.84 | 677 | 3.11 | 703 | 3.39 | 728 | 3.67 | 751 | 3.95 | 774 | 4.24 |
| 6500 | 628 | 2.71 | 656 | 2.98 | 683 | 3.27 | 709 | 3.55 | 734 | 3.84 | 757 | 4.13 | 780 | 4.43 |
| 6750 | 635 | 2.86 | 663 | 3.14 | 689 | 3.43 | 715 | 3.72 | 739 | 4.02 | 763 | 4.32 | 786 | 4.62 |
| 7000 | 642 | 3.01 | 669 | 3.30 | 696 | 3.60 | 721 | 3.90 | 745 | 4.20 | 769 | 4.51 | 792 | 4.82 |
| 7250 | 649 | 3.17 | 676 | 3.47 | 702 | 3.77 | 727 | 4.08 | 752 | 4.39 | 775 | 4.71 | — | — |
| 7500 | 656 | 3.34 | 683 | 3.65 | 709 | 3.96 | 734 | 4.27 | 758 | 4.59 | 781 | 4.91 | — | — |
| 7750 | 663 | 3.52 | 690 | 3.83 | 715 | 4.15 | 740 | 4.47 | 764 | 4.80 | — | — | — | — |
| 8000 | 671 | 3.71 | 697 | 4.02 | 722 | 4.35 | 747 | 4.67 | — | — | — | — | — | — |
| 8250 | 679 | 3.90 | 705 | 4.22 | 730 | 4.55 | 754 | 4.89 | — | — | — | — | — | — |
| 8500 | 687 | 4.11 | 712 | 4.44 | 737 | 4.77 | — | — | — | — | — | — | — | — |
| 8750 | 695 | 4.32 | 720 | 4.66 | 744 | 5.00 | — | — | — | — | — | — | — | — |
| 9000 | 704 | 4.55 | 728 | 4.89 | — | — | — | — | — | — | — | — | — | — |
| 9250 | 712 | 4.78 | — | — | — | — | — | — | — | — | — | — | — | — |
| 9500 | — | — | — | — | — | — | — | — | — | — | — | — | — | — |
| 9750 | — | — | — | — | — | — | — | — | — | — | — | — | — | — |

LEGEND

Bhp — Brake Horsepower
ESP — External Static Pressure

NOTES:

- Units are available with several motor hp options. Refer to Physical Data table.
- Static pressure losses for any options or accessories must be applied to external static pressure before entering the fan performance table.
- Interpolation is permitted; extrapolation is not.
- Fan performance is based on unit casing, and dry DX (direct expansion) coil losses at sea level.

Performance data (cont)



CONDENSER FAN PERFORMANCE (cont)

| 09XC24 (20 Tons) | | | | | | | | | | | | | | | | |
|------------------|--------------|------|------|------|------|------|------|------|------|------|------|------|------|------|------|------|
| CFM | ESP (in. wg) | | | | | | | | | | | | | | | |
| | 0.00 | | 0.10 | | 0.20 | | 0.30 | | 0.40 | | 0.50 | | 0.60 | | 0.70 | |
| | Rpm | Bhp | Rpm | Bhp | Rpm | Bhp | Rpm | Bhp | Rpm | Bhp | Rpm | Bhp | Rpm | Bhp | Rpm | Bhp |
| 8,500 | 594 | 1.60 | 636 | 1.84 | 682 | 2.14 | 724 | 2.44 | 764 | 2.74 | 801 | 3.04 | 837 | 3.35 | 870 | 3.66 |
| 8,800 | 606 | 1.72 | 655 | 2.02 | 700 | 2.33 | 741 | 2.64 | 780 | 2.95 | 817 | 3.27 | 852 | 3.58 | 885 | 3.90 |
| 9,100 | 626 | 1.90 | 674 | 2.22 | 718 | 2.54 | 758 | 2.85 | 797 | 3.18 | 833 | 3.50 | 867 | 3.82 | 900 | 4.15 |
| 9,400 | 647 | 2.09 | 693 | 2.42 | 736 | 2.75 | 776 | 3.08 | 813 | 3.41 | 849 | 3.74 | 882 | 4.08 | 915 | 4.41 |
| 9,700 | 668 | 2.30 | 713 | 2.64 | 754 | 2.98 | 793 | 3.32 | 830 | 3.66 | 865 | 4.00 | 898 | 4.35 | 930 | 4.69 |
| 10,000 | 688 | 2.52 | 732 | 2.87 | 773 | 3.22 | 811 | 3.57 | 847 | 3.92 | 881 | 4.27 | 914 | 4.63 | 945 | 4.99 |
| 10,300 | 709 | 2.75 | 752 | 3.11 | 791 | 3.47 | 829 | 3.83 | 864 | 4.20 | 898 | 4.56 | 930 | 4.92 | 961 | 5.29 |
| 10,600 | 730 | 3.00 | 771 | 3.37 | 810 | 3.74 | 846 | 4.11 | 881 | 4.49 | 914 | 4.86 | 946 | 5.23 | 976 | 5.61 |
| 10,900 | 750 | 3.26 | 791 | 3.64 | 829 | 4.02 | 864 | 4.41 | 898 | 4.79 | 931 | 5.17 | 962 | 5.56 | 992 | 5.95 |
| 11,200 | 771 | 3.54 | 810 | 3.93 | 847 | 4.32 | 882 | 4.71 | 916 | 5.11 | 948 | 5.50 | 979 | 5.90 | 1008 | 6.29 |
| 11,500 | 792 | 3.83 | 830 | 4.23 | 866 | 4.64 | 901 | 5.04 | 933 | 5.44 | 965 | 5.85 | 995 | 6.25 | 1024 | 6.66 |
| 11,800 | 812 | 4.14 | 850 | 4.55 | 885 | 4.96 | 919 | 5.38 | 951 | 5.79 | 982 | 6.21 | 1012 | 6.62 | 1041 | 7.04 |
| 12,100 | 833 | 4.46 | 869 | 4.88 | 904 | 5.31 | 937 | 5.73 | 969 | 6.16 | 999 | 6.58 | 1029 | 7.01 | 1057 | 7.43 |
| 12,400 | 854 | 4.80 | 889 | 5.24 | 923 | 5.67 | 956 | 6.10 | 987 | 6.54 | 1017 | 6.97 | 1046 | 7.41 | 1074 | 7.85 |
| 12,700 | 874 | 5.16 | 909 | 5.60 | 942 | 6.05 | 974 | 6.49 | 1005 | 6.94 | 1034 | 7.38 | 1063 | 7.83 | 1090 | 8.28 |

| 09XC24 (20 Tons) (cont) | | | | | | | | | | | | | | | | |
|-------------------------|--------------|------|------|------|------|------|------|------|------|------|------|------|------|-------|--|--|
| CFM | ESP (in. wg) | | | | | | | | | | | | | | | |
| | 0.80 | | 0.90 | | 1.00 | | 1.10 | | 1.20 | | 1.30 | | 1.40 | | | |
| | Rpm | Bhp | Rpm | Bhp | Rpm | Bhp | Rpm | Bhp | Rpm | Bhp | Rpm | Bhp | Rpm | Bhp | | |
| 8,500 | 902 | 3.97 | 933 | 4.28 | 963 | 4.59 | 992 | 4.91 | 1020 | 5.22 | 1046 | 5.54 | 1073 | 5.87 | | |
| 8,800 | 917 | 4.22 | 947 | 4.54 | 976 | 4.86 | 1005 | 5.19 | 1032 | 5.51 | 1059 | 5.84 | 1085 | 6.17 | | |
| 9,100 | 931 | 4.48 | 961 | 4.81 | 990 | 5.14 | 1018 | 5.48 | 1046 | 5.81 | 1072 | 6.15 | 1098 | 6.49 | | |
| 9,400 | 946 | 4.75 | 975 | 5.09 | 1004 | 5.44 | 1032 | 5.78 | 1059 | 6.13 | 1085 | 6.48 | 1111 | 6.83 | | |
| 9,700 | 960 | 5.04 | 990 | 5.39 | 1018 | 5.74 | 1046 | 6.10 | 1072 | 6.45 | 1098 | 6.81 | 1124 | 7.17 | | |
| 10,000 | 975 | 5.34 | 1004 | 5.70 | 1032 | 6.07 | 1060 | 6.43 | 1086 | 6.80 | 1112 | 7.16 | 1137 | 7.53 | | |
| 10,300 | 990 | 5.66 | 1019 | 6.03 | 1047 | 6.40 | 1074 | 6.77 | 1100 | 7.15 | 1126 | 7.53 | 1150 | 7.91 | | |
| 10,600 | 1006 | 5.99 | 1034 | 6.37 | 1062 | 6.75 | 1088 | 7.13 | 1114 | 7.52 | 1139 | 7.91 | 1164 | 8.29 | | |
| 10,900 | 1021 | 6.33 | 1049 | 6.72 | 1076 | 7.11 | 1103 | 7.51 | 1128 | 7.90 | 1153 | 8.30 | 1178 | 8.70 | | |
| 11,200 | 1037 | 6.69 | 1064 | 7.09 | 1091 | 7.49 | 1117 | 7.90 | 1143 | 8.30 | 1168 | 8.71 | 1192 | 9.11 | | |
| 11,500 | 1053 | 7.07 | 1080 | 7.48 | 1106 | 7.89 | 1132 | 8.30 | 1157 | 8.71 | 1182 | 9.13 | 1206 | 9.55 | | |
| 11,800 | 1069 | 7.46 | 1096 | 7.88 | 1122 | 8.30 | 1147 | 8.72 | 1172 | 9.15 | 1196 | 9.57 | 1220 | 10.00 | | |
| 12,100 | 1085 | 7.86 | 1111 | 8.29 | 1137 | 8.73 | 1162 | 9.16 | 1187 | 9.59 | — | — | — | — | | |
| 12,400 | 1101 | 8.29 | 1127 | 8.73 | 1153 | 9.17 | 1178 | 9.61 | — | — | — | — | — | — | | |
| 12,700 | 1117 | 8.73 | 1143 | 9.18 | 1169 | 9.63 | — | — | — | — | — | — | — | — | | |

LEGEND

Bhp — Brake Horsepower
ESP — External Static Pressure

NOTES:

- Units are available with several motor hp options. Refer to Physical Data table.
- Static pressure losses for any options or accessories must be applied to external static pressure before entering the fan performance table.
- Interpolation is permitted; extrapolation is not.
- Fan performance is based on unit casing, and dry DX (direct expansion) coil losses at sea level.

Electrical data



FAN ELECTRICAL DATA

| MOTOR CODE | HP | V-PH-Hz | VOLTAGE RANGE | | FLA | MCA | MOPD | DISC |
|------------|------|--------------|---------------|-----|-----------|-----------|-------|------|
| | | | Min | Max | | | | |
| D | 1.00 | 208/230-3-60 | 187 | 253 | 3.2/3.2 | 4.0/4.0 | 15/15 | 30 |
| | | 460-3-60 | 414 | 506 | 1.6 | 2.0 | 15 | 30 |
| | | 575-3-60 | 518 | 632 | 1.1 | 1.4 | 15 | 30 |
| E | 1.50 | 208/230-3-60 | 187 | 253 | 4.6/4.8 | 5.8/6.0 | 15/15 | 30 |
| | | 460-3-60 | 414 | 506 | 2.4 | 3.0 | 15 | 30 |
| | | 575-3-60 | 518 | 632 | 1.6 | 1.9 | 15 | 30 |
| F | 2.00 | 208/230-3-60 | 187 | 253 | 6.0/5.8 | 7.5/7.2 | 15/15 | 30 |
| | | 460-3-60 | 414 | 506 | 2.9 | 3.6 | 15 | 30 |
| | | 575-3-60 | 518 | 632 | 2.1 | 2.6 | 15 | 30 |
| G | 3.00 | 208/230-3-60 | 187 | 253 | 9.2/8.6 | 11.5/10.8 | 20/15 | 30 |
| | | 460-3-60 | 414 | 506 | 4.3 | 5.4 | 15 | 30 |
| | | 575-3-60 | 518 | 632 | 3.4 | 4.2 | 15 | 30 |
| H | 5.00 | 208/230-3-60 | 187 | 253 | 14.5/13.6 | 18.1/17.0 | 30/30 | 30 |
| | | 460-3-60 | 414 | 506 | 6.8 | 8.5 | 15 | 30 |
| | | 575-3-60 | 518 | 632 | 5.4 | 6.8 | 15 | 30 |
| J | 7.50 | 208/230-3-60 | 187 | 253 | 21.5/19.4 | 26.9/24.2 | 45/40 | 30 |
| | | 460-3-60 | 414 | 506 | 9.7 | 12.1 | 20 | 30 |
| | | 575-3-60 | 518 | 632 | 7.5 | 9.4 | 15 | 30 |

LEGEND

- FLA** — Full Load Amps
- DISC** — Disconnect
- MCA** — Minimum Circuit Amps
- MOPD** — Minimum Overcurrent Protection Device
- NEC** — National Electrical Code
- RLA** — Rated Load Amps

2. Wire sizing amps are a sum of 125% of the compressor RLA plus 100% of indoor fan motor FLA.
3. Motors are protected against primary single phasing condition.
4. Indoor-fan motors are 3-phase motors of same voltage as unit.

NOTES:

1. In compliance with NEC requirements for multimotor and combination load equipment (NEC Articles 430 and 440), the overcurrent protective device for the unit shall be fuse or HACR circuit breaker. Canadian units may be fuse or circuit breaker.



Typical wiring schematics



FIELD WIRING

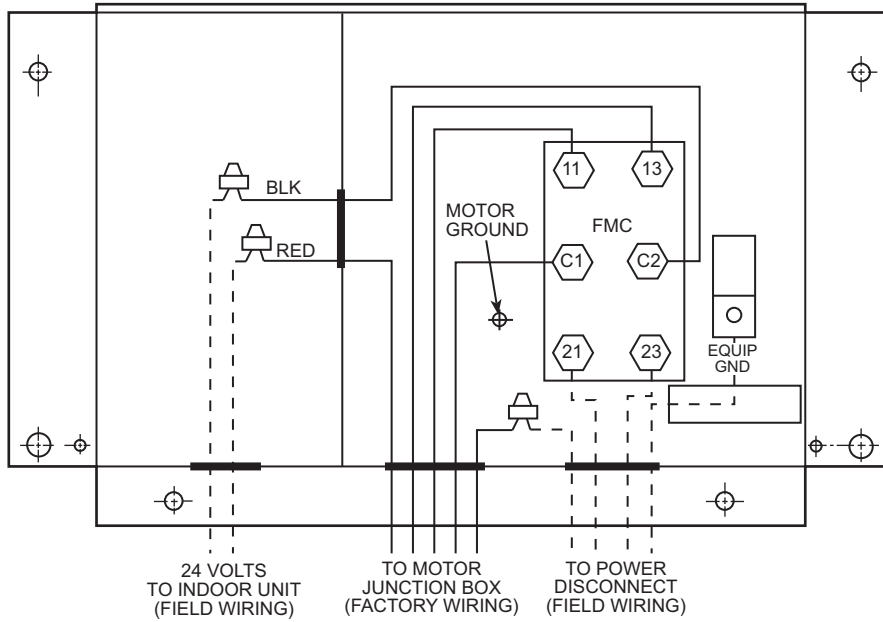

LABEL DIAGRAM

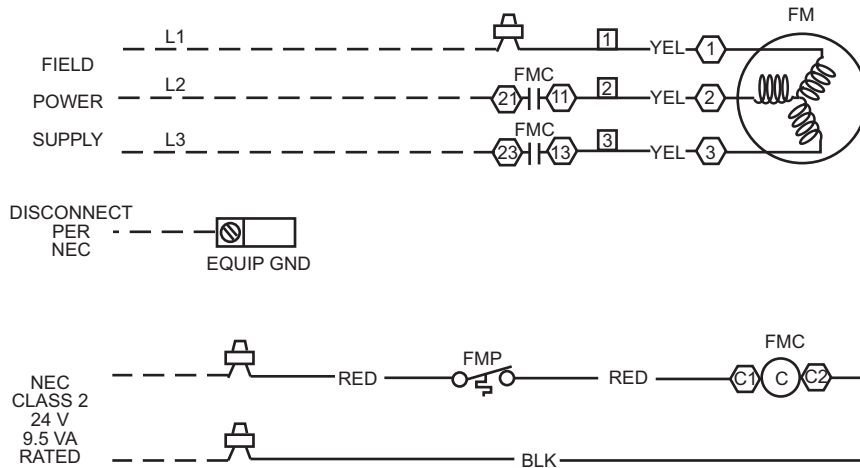

LEGEND

- EQUIP GND** — Equipment Ground
- FM** — Fan Motor
- FMC** — Fan Motor Contactor
- FMP** — Internal Fan Motor Protector
- NEC** — National Electrical Code

TYPICAL WIRING SCHEMATIC FOR LOW AMBIENT OPTION (09XC06,08 UNITS)

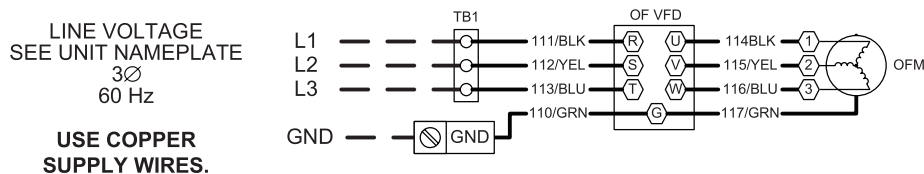

WITHOUT FACTORY INSTALLED DISCONNECT SWITCH

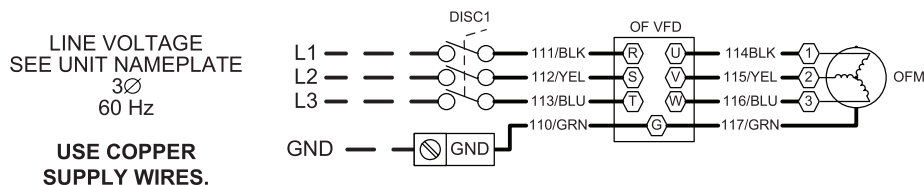

FACTORY INSTALLED DISCONNECT SWITCH OPTION



LOW VOLTAGE CONTROLS

| LEGEND | |
|---------------|---------------------------|
| C — | Compressor Contactor |
| DISC — | Disconnect |
| GND — | Ground |
| OFM — | Outdoor-Fan Motor |
| OFR — | Outdoor-Fan Relay |
| PRES — | Pressure Transducer |
| TB — | Terminal Block |
| VFD — | Variable Frequency Drive |
| | Terminal Block Connection |
| | Marked Terminal |
| | Unmarked Terminal |
| | Splice |
| | Factory Wiring |
| | Field Power Wiring |

NOTES:

1. Fan motors are inherently thermally protected.
2. Three-phase motors are protected under primary single phase conditions.
3. Use conductors suitable for at least 194 F (90 C) when replacing factory wiring.
4. Use copper conductors only.
5. Wiring for field power supply must be rated at 165 F (75 C) minimum.

Typical wiring schematics (cont)



TYPICAL WIRING SCHEMATIC FOR LOW AMBIENT OPTION (09XC12-24 UNITS)

LINE VOLTAGE
SEE UNIT NAMEPLATE
3Ø
60 Hz

USE COPPER
SUPPLY WIRES.

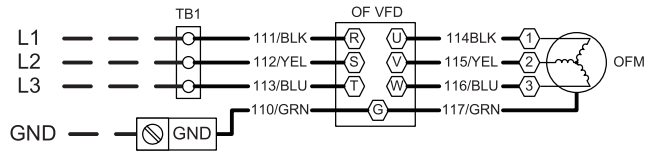

WITHOUT FACTORY INSTALLED DISCONNECT SWITCH

LINE VOLTAGE
SEE UNIT NAMEPLATE
3Ø
60 Hz

USE COPPER
SUPPLY WIRES.

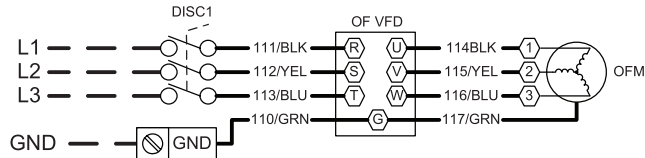

FACTORY INSTALLED DISCONNECT SWITCH OPTION

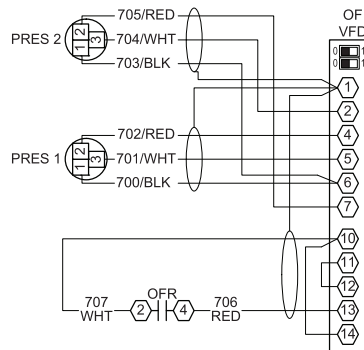
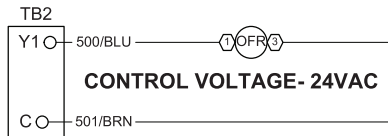

Note: PRES1, PRES2, and OFR are connected with shielded wire. The drain wire is connected to OF VFD terminal 1. The remote end of the drain wire shall be insulated.

LOW VOLTAGE CONTROLS

LEGEND

| | |
|---------------------------------------|---------------------------|
| C — Compressor Contactor | Terminal Block Connection |
| DISC — Disconnect | Marked Terminal |
| GND — Ground | Unmarked Terminal |
| OFM — Outdoor-Fan Motor | Splice |
| OFR — Outdoor-Fan Relay | Factory Wiring |
| PRES — Pressure Transducer | Field Power Wiring |
| TB — Terminal Block | |
| VFD — Variable Frequency Drive | |

NOTES:

1. Fan motors are inherently thermally protected.
2. Three-phase motors are protected under primary single phase conditions.
3. Use conductors suitable for at least 194 F (90 C) when replacing factory wiring.
4. Use copper conductors only.
5. Wiring for field power supply must be rated at 165 F (75 C) minimum.

Controls



Operating sequence

The 09XC condensing unit may be used with different types of compressor and evaporator combinations. The sequence of operation is dependent on the compressor and indoor unit that the condenser is used with. In general, whenever there is a call for cooling the condenser fan starts with the compressor and runs as long as there is a call for cooling. Fans are activated on the call for first stage and run with the lead compressor.

When matched with the 50XCR units, the 09XC sequence of operation is as follows:

On a call for cooling, the thermostat closes and energizes terminals Y1 and T1 on the 50XCR unit low voltage terminal strip. The fan motor contactor (FMC) is energized with 24 v through terminals T1 and C. The fan will continue to run until the thermostat is satisfied. At that time, the thermostat will open T1, and the fan will stop immediately.

If the condenser-fan motor overheats due to motor overload or lack of cooling air, the internal fan protector (FMP) will open the circuit to the motor, and the fan will stop. If a safety control in the unit opens, the 09XC condenser fan

will not be affected, and the fan will continue to run as long as the thermostat is closed.

Operating sequence with accessories

If the condenser is equipped with low ambient control, the option controls condenser fan airflow in response to the saturated condensing temperature. Accessory winter start control should be used with low ambient temperatures to bypass the low-pressure switch for 90 seconds on compressor start-up. This allows system pressures to stabilize.

A field-supplied solenoid valve (locate at indoor unit), wired in parallel with the compressor contactor coil, shuts off the liquid line to prevent the refrigerant migration back to the compressor during the off cycle. This valve is recommended for installations with piping length over 75 ft (22.9 m). If two liquid line solenoid valves are used (09XC12-24 units), check available transformer VA capability.

Low ambient control on 09XC units is accomplished with a VFD (variable frequency drive) on the condenser fan. Low ambient operation does not affect operating sequence.

Typical piping and wiring



09XC UNIT MATCHED WITH 50XCR INDOOR UNIT

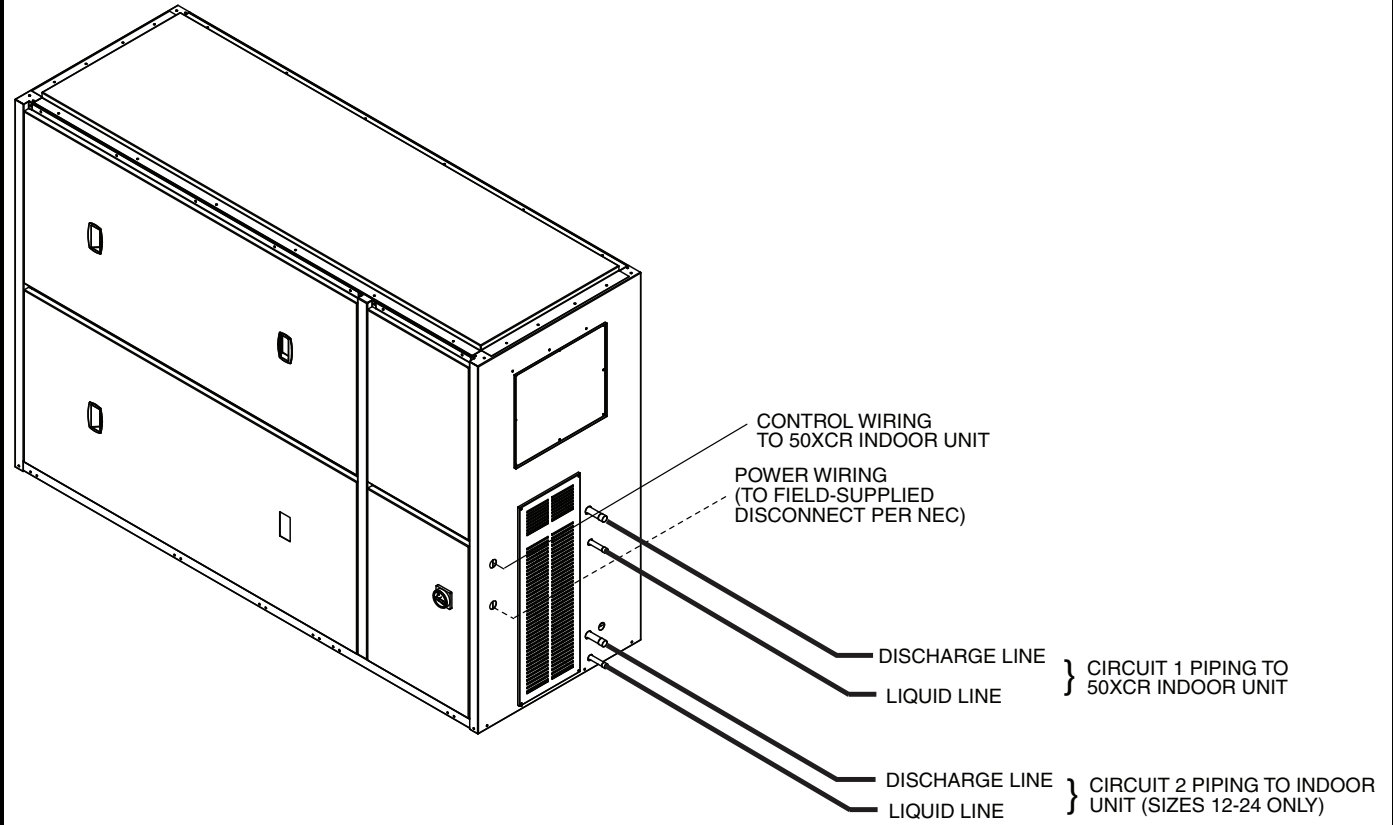

LEGEND

NEC — National Electrical Code

Application data



Location

For best results unit must be properly located and installed. Locate condenser where an adequate supply of inlet outdoor air is available. Do not locate unit where the possibility of air recirculation exists. Locate condenser in an area free from airborne dirt or other foreign material which could clog condenser coils. Selected location should not be adjacent to an acoustically sensitive space, for example a conference room or executive office. The best location is in mechanical rooms or garages near areas like elevators, restrooms, stairways or similar spaces. The mechanical room should use construction methods which will help to isolate the transmission of acoustical energy.

Since these units are typically used indoors and require large quantities of ducted condenser air, select a location with the best access to outside window or wall to accommodate condenser air louver. Locate the unit as close to the wall opening as possible but allow space for access to the condenser coil for cleaning. Units on the same floor should have a minimum of 6 ft between units to prevent recirculation of condenser air. Units should have a minimum of 10 ft between units to prevent recirculation.

Units should not be located with several units pulling condenser air from a small space between buildings which may be recirculated. Recirculation of condenser air will result in increased head pressure which may cause units to trip on high pressure.

Unit mounting

When units are mounted to use an existing window height, a field-fabricated steel mounting stand is recommended. The stand should be built rigid enough to support the weight of the unit and braced to prevent any side to side movement of the stand. A mounting height higher than the window sill height is recommended which will allow the condenser duct to be pitched back to the louver in the window for rain elimination and drainage.

Make sure units are installed level to ensure proper drainage of liquid refrigerant and oil. When unit is in proper location, use mounting holes in legs for securing unit to supporting structure.

Unit may also be suspended from above. Support unit with steel channels under unit and attach to ceiling structure by steel rods. Be sure all supports can sustain unit weight.

Unit isolation

If vibration isolation is desired, rubber-in shear pads or spring isolators with 1-in. deflection are recommended under the four corners of the unit. All duct connections to the unit should be made with flexible connections to prevent any transmission of vibration to the ductwork.

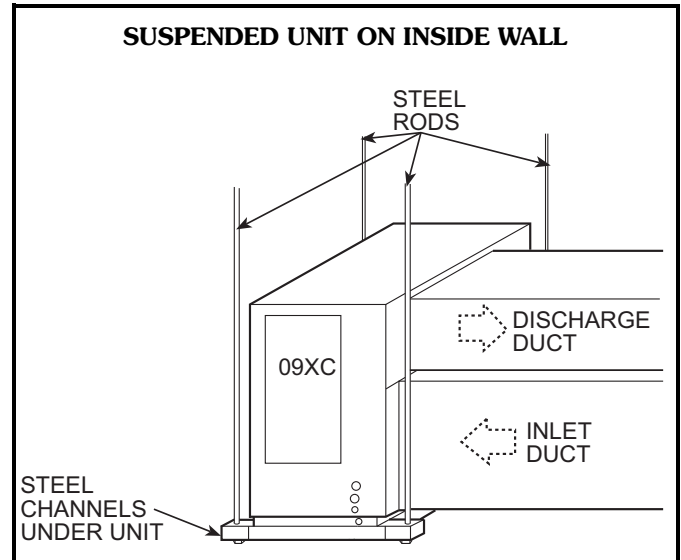

Condenser ductwork

Condenser supply and discharge air ducts should be as short and straight as possible. Cross-sectional area of the inlet and discharge should never be less than the face area of the unit openings. When bends must be made, they should be as gradual as space limitations will allow. If the unit will be operated in cold outdoor weather or if dampers are not provided at the louver, then the condenser ducts and unit should be insulated to prevent condensation.

Design of the field-supplied and installed louver used for the inlet and discharge of the condenser airflow is critical to preventing recirculating of air and high pressure trips. The louver blades must be heavy enough to prevent unit airflow from drawing them together. Louver blades should be a minimum of 18 gage and widths over 30 in. should have stiffeners. The inlet louver should not have a flange and the discharge louver should have a flange which directs the air away from the inlet. The use of a field-supplied deflector in conjunction with the condenser air discharge is also recommended.

Operational limits

Condenser air temperature

Maximum: 115 F

Minimum: 55 F

Liquid lift and subcooler circuit

Amount of liquid lift available before refrigerant flashing occurs depends on amount of liquid subcooling in the system. All 09XC condensers have positive subcooling when applied with optimum charge. With subcooling, it is possible to overcome an appreciable pressure drop and/or static head pressure (due to elevation of the liquid metering device above the condenser when condenser is below evaporator coil). However subcooling will decrease the total heat rejection capability of the condenser. This is because subcooling results from a portion of the condenser tubes being filled with liquid refrigerant, decreasing the area for condensing to occur.

Application data (cont)



When 09XC condensers are applied with minimum charge, they do not provide positive subcooling. If subcooling is required, it must be obtained by external means such as a liquid suction interchanger. It is recommended that the evaporator be either at the same level as the condenser or lower than the condenser when minimum charge is used.

Refrigerant line sizing

Sizing depends on length of lines between various sections of the refrigerant system. Consider the amount of liquid lift and drop in the system as well as proper compressor oil return. Consult Carrier System Design Manual, Part 3, for proper piping sizes and design.

Use the following guideline for refrigerant piping:

Discharge lines

1. Base line size on a 2° F change in saturated condensing temperature.
2. Lines must be sized and routed so that oil is carried through the system. When the condenser is located at a higher level than the compressor, take special precautions that oil will return at reduced capacity. A double hot gas riser may be required with high lift and a large degree of unloading. Be sure to trap the connections between both risers.
3. Protect the compressor from liquid refrigerant or oil draining back during compressor off cycles by ensuring the following:
 - a. The highest point in the discharge line should be above the highest point in the condenser coil. A purge valve should be applied at this point.
 - b. The hot gas line should loop to the floor if the condenser is located above the compressor, especially if the hot gas riser is long.
 - c. If the condenser is located where the ambient temperature could be higher than the ambient at the compressor location, a check valve should be installed in the hot gas line.

Liquid lines

1. Liquid line can generally be sized for a 1° to 2° F degree change in saturation temperature.

2. A receiver, if used in the system, should be located below the condenser. The condenser to receiver liquid line must be sized to allow free drainage. This line should be sized so the velocity does not exceed 100 fpm.
3. Generous sizing of this liquid (condensate) line is especially important if the receiver is exposed at any time to a warmer ambient temperature than the condenser. It must be large enough for the liquid to flow to the receiver and at the same time allow flow or refrigerant vapor in the opposite direction back to the condenser. The receiver will become vapor locked under these conditions if re-evaporated gas is not allowed to flow back to the condenser for re-condensation.
4. Liquid lines should be free of any traps or loops.

Piping should be routed to avoid excessive strain on system components or the piping itself. Discharge lines must be supported with rigid pipe supports to prevent transmission of vibration and movement of the line. The discharge line should be well supported near the condenser hot gas connection. Use offsets in interconnecting lines between two condensers and provide isolation where pipes pass through building walls or floors.

Setting condenser fan speed

The 09XC condenser has a centrifugal blower and a variable pitch drive which allow adjusting the condenser airflow to match the static from the louvers, ductwork, filters and sound traps (if used). It is best to adjust the fan to the nominal airflow and the rpm which will achieve this performance. Excess airflow and rpm will make units noisier.

Sound considerations

When unit is installed in or near areas requiring additional sound attenuation:

- Locate unit in equipment room or closet
- Use acoustic lining in ductwork
- Provide square duct elbows with acoustic lining and turning vanes

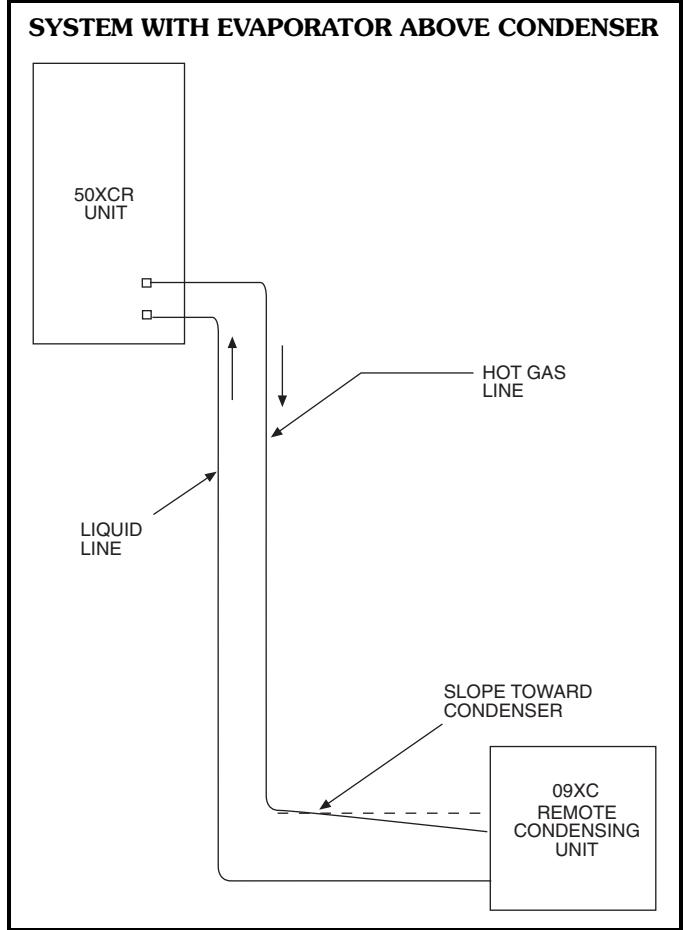
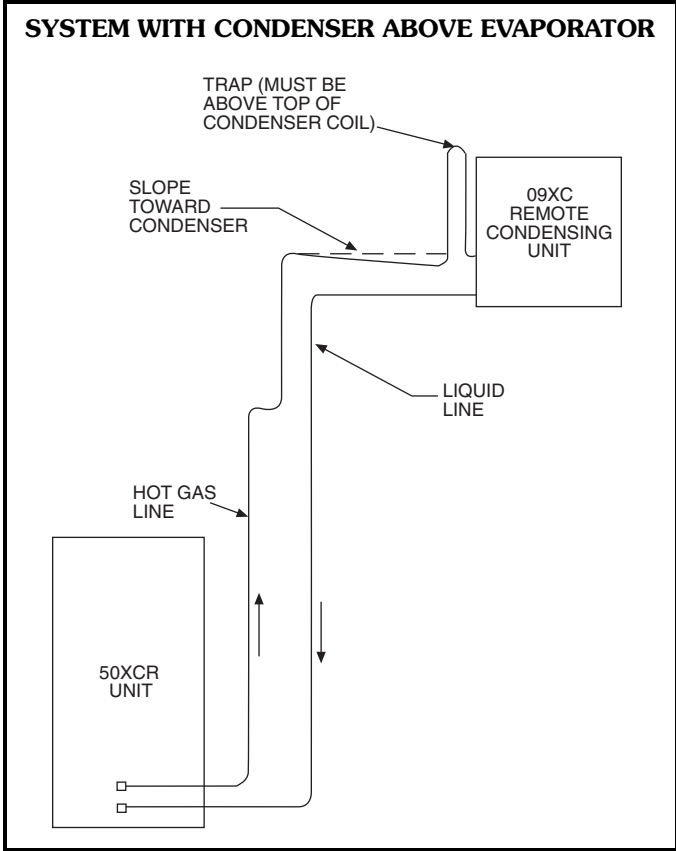

Guide specifications



Remote Air-Cooled Condenser Unit

HVAC Guide Specifications

Size Range: **5 to 20 Tons**

Carrier Model Number: **09XC**

Part 1 — General

1.01 SYSTEM DESCRIPTION

Indoor mounted, air-cooled condenser with belt drive centrifugal fan. Air shall discharge horizontally with inlet and outlet on the same face of the unit.

1.02 QUALITY ASSURANCE

- A. Units shall be rated using refrigerant R-410A. Ratings shall be listed at a minimum (5° F subcooling) and optimum (15° F subcooling) refrigerant charge and in accordance with AHRI Standard 340/360, latest edition.
- B. Unit shall be designed to conform to ANSI/ASHRAE 15, latest revision safety code, and UL Standard 1995, and shall be UL listed under both American and Canadian Standards.
- C. Coils shall be leak tested at 420 psig and unit operation shall be tested at the factory.

1.03 DELIVERY, STORAGE, AND HANDLING

Units shall be stored and handled according to manufacturer's recommendations.

Part 2 — Products

2.01 EQUIPMENT

A. General:

Indoor mounted, packaged, air-cooled remote condenser unit. Factory-assembled unit shall consist of condenser coil, fan with motor and drive, factory wiring, piping and electrical controls, and a charge of dry nitrogen.

B. Cabinet:

Cabinet shall be steel frame construction with removable access panels for control box and motor drive adjustment. Panels shall be of zinc-coated bonderized steel finish with baked enamel paint. Unit cabinet shall be capable of withstanding Federal Test Method Standard No. 141 (method 6061) 500-Hour Salt Spray Test.

C. Fans:

1. Fans shall be double inlet, centrifugal wheel with forward-curved blades, designed for continuous operation. Fan wheel and scroll shall

be constructed of steel with corrosion resistant finish, and statically and dynamically balanced.

2. Fan shall be belt drive with an adjustable pitch motor pulley, with permanently lubricated, ball-bearing type bearings.
3. Discharge side of condenser fan shall be protected by corrosion proof fan guards.

D. Coils:

Coils shall use seamless copper tube, aluminum plate fins and galvanized steel tube sheets. Fins shall be bonded to tubes by mechanical expansion. Hot gas and liquid connections shall be made at the same end of the coil. Units shall be circuited for one or two circuits with each circuit having an integral subcooling circuit. Multiple circuit coils shall be capable of being field connected to single circuit.

E. Motor:

Motors shall be TEFC (Totally Enclosed Fan Cooled). Motors with internal overload protection, protected to operate at the specified electrical characteristics. Motors shall be 3 phase.

F. Controls:

Unit shall be provided with a contactor to control the condenser fan motor. Contactor shall be controlled by 24 volt power. Motor internal overload protection shall open contactor on a motor overload.

G. Operating Characteristics:

Units shall be capable of rejecting the required heat at the nominal cfm. Unit shall be capable of adjustment to allow operation with ductwork and field-supplied inlet and discharge louvers as shown on the contract drawings. Units shall be capable of operation at 55 to 115 F ambient temperatures as standard.

H. Electrical Characteristics:

Units shall be capable of operating on 3 phase. Electrical characteristics as specified in the equipment schedule. Control voltage shall be 24 volts from external source.

I. Special Features:

Low Ambient Operation:

Units shall provide refrigerant pressure controlled VFD (variable frequency drive) to adjust condenser fan speed to control head pressure as a factory-installed option. This fan speed control permits unit to operate in cooling even in winter, when outdoor air temperature is down to 0° F.

