



Product Data

EVERGREEN® 19XR,XRV High-Efficiency Hermetic Centrifugal Liquid Chiller 50/60 Hz HFC-134a

200 to 1500 Nominal Tons (703 to 5275 kW)

Evergreen® CHILLERS

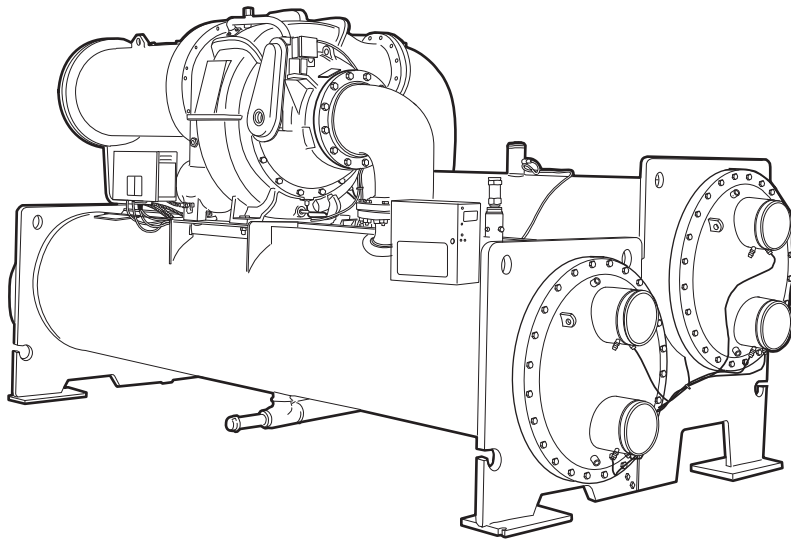

19XR,XRV

SEISMICOMPLIANT*

* Meets IBC 2006, ASCE-7-05, CBC 2007, and OSHPD seismic requirements.

ASHRAE
90.1
COMPLIANT

Carrier's Evergreen® centrifugal chillers offer:

- The use of non-ozone depleting refrigerant HFC-134a, which is not affected by scheduled refrigerant phaseouts
- An annual leak rate of 0.1%, the lowest published in the industry
- The ability to store the entire charge of refrigerant inside the chiller, minimizing the chance of leaks during refrigerant transfer for maintenance
- Hermetic compression
- Refrigerant-cooled VFD (variable frequency drive) (19XRV only)
- Modular construction
- Positive pressure design
- Variable diffuser optimization logic, which can improve the integrated part load values (IPLV) (available on compressor frame sizes 4 and 5 with diffuser control enabled)

Features/Benefits

The Carrier-designed Evergreen family of chillers achieve superior efficiencies without compromising the environment.

The Evergreen chillers superior efficiencies are obtained at true operating conditions. Therefore, the effects of potential direct or indirect global warming are greatly diminished.

High efficiency

Today's owners of chilled water plants demand high efficiency from their chillers. Per AHRI (Air Conditioning, Heating and Refrigeration Institute) 550/590, chillers operate at design conditions less than one percent of the time.

Features/Benefits (cont)



As a result, superior part load efficiency is required for today's chilled water applications.

The Evergreen® 19XRV centrifugal chiller, equipped with a factory-installed variable speed drive, maximizes chiller efficiency by optimizing compressor operation. Electric power consumption drops dramatically when the motor speed slows. The 19XRV chiller delivers industry-leading integrated part load values (IPLV).

The Evergreen chiller with diffuser control enabled (available on compressor frame sizes 4 and 5) improves the chiller's part load efficiency by increasing the diffuser opening. Diffuser position is not only based on inlet guide vane (IGV) position, but also on lift.

Environmental leadership

Carrier has long been committed to the environment and its sustainability. Evergreen chillers provide our customers with a high-efficiency, chlorine-free long-term solution unaffected by refrigerant phaseouts. Carrier's decision to utilize non-ozone depleting HFC-134a refrigerant provides our customers with a safe and environmentally sound choice without compromising efficiency.

Reliability

The Evergreen chiller's simple, single-stage positive-pressure compressor, coupled with ASME-constructed heat exchangers, ensures superior reliability and sustainability. Carrier's hermetic motors operate in a clean-liquid, refrigerant-cooled environment. The hermetic design eliminates the potential for shaft seal leaks and refrigerant/oil loss. These are just some of the reasons why the Evergreen family of chillers has the industry's lowest leak rate.

Positive pressure design

The Evergreen chiller's positive pressure design reduces the chiller size by up to 35% compared to low-pressure designs. The smaller size minimizes the need for valuable mechanical room floor space. In addition, positive pressure designs eliminate the need for costly low-pressure containment devices, reducing the initial cost of the system.

The Evergreen chiller advantage

The Evergreen chiller can be shipped fully charged, minimizing start-up and

maintenance time. Purge units are not required. The tight construction of the Evergreen centrifugal chiller ensures that contaminants stay out and efficiency is maintained throughout the life of the chiller.

Modular construction

The cooler, condenser, and compressor assemblies are completely bolted together, making the Evergreen chillers ideally suited for replacement projects where ease of disassembly and reassembly at the jobsite are essential.

Marine container shipment (19XR, heat exchanger frame sizes 1 to 6 only)

The compact design allows for open-top container shipment to export destinations, ensuring product quality while reducing shipping cost.

Optional refrigerant isolation valves

This system allows the refrigerant to be stored inside the chiller during servicing, reducing refrigerant loss and eliminating time-consuming transfer procedures. As a self-contained unit, the Evergreen chillers do not require additional remote storage systems.

Optional pumpdown unit

Combined with the refrigerant isolation valves listed above, the optional pumpdown unit eliminates complex connections to portable transfer systems, thereby reducing service costs. In addition, the optional pumpdown compressor meets Environmental Protection Agency's (EPA's) vacuum level requirements that mandate minimizing refrigerant emissions during service.

Optional unit-mounted starter

Available in low-voltage wye-delta and solid state, Carrier's unit-mounted starter provides a single point power connection, reducing chiller installation time and expense. (Available on heat exchanger frame sizes 1 to 7 only.)

Optional seismic kit

A seismic isolation package is available to meet International Building Code and ASCE (American Society of Civil Engineers) 7 seismic qualification requirements in concurrence with ICC ES (International Code Council Evaluation Service) AC156 Acceptance Criteria for Seismic Qualification by Shake-Table Testing of Nonstructural Components and Systems.

Hermetic compressor features

Single-stage design increases product reliability by eliminating the additional moving parts associated with multiple stage chillers, such as additional guide vanes and complex economizers.

Aerodynamically contoured impellers use high back sweep main blades with low-profile intermediate splitter blades. The impellers are aerodynamically contoured to improve compressor full load and part load operating efficiency.

Pipe diffuser design uses jet engine technology, increasing centrifugal compressor peak efficiency.

Hermetic motors are hermetically sealed from the machine room; cooling is accomplished by spraying liquid refrigerant on the motor windings. This highly efficient motor cooling method results in the use of smaller, cooler-running motors than could be realized

Table of contents

	Page
Features/Benefits	1-4
Model Number Nomenclature	5
Chiller Components	6,7
Physical Data	8-26
Options and Accessories	27,28
Dimensions	29-31
Selection Procedure	31
Electrical Data	31
Controls	32-34
Typical Piping and Wiring	35,36
Application Data	37-46
Guide Specifications	47-55

with air-cooled designs of the same type.

In addition, Carrier's hermetic design eliminates:

- Compressor shaft seals that require maintenance and increase the likelihood of refrigerant leaks
- Shaft alignment problems that occur with open-drive designs during start-up and operation, when equipment temperature variations cause thermal expansion
- High noise levels that are common with air-cooled motors, which radiate noise to the machine room and adjacent areas
- Machine room cooling requirements associated with air-cooled motors, which dissipate heat to the machine room

Compressors are 100% run-tested to ensure proper operation of all compressor systems, including oil management, vibration, electrical, power transmission, and compression.

Heat exchanger features

The American Society of Mechanical Engineers (ASME) standard requires the use of an independent agency to certify the design, manufacture, and testing of all heat exchangers, ensuring the ultimate in heat exchanger safety, reliability, and long life.

Refrigerant-cooled VFD (19XRV) minimizes VFD size and ensures proper cooling of the transistors for extended life. Using R-134a refrigerant instead of water also eliminates costly maintenance associated with the water cooling pump, heat exchanger and rubber tubing used with water-cooled VFDs.

1-in. cooler tubes provide better efficiency and less pressure drop than standard tubes.

Cooler tube expansion at center support sheets prevents unwanted tube movement and vibration, thereby reducing the possibility of premature tube failure.

Double-grooved tube sheet holes eliminate the possibility of leaks between the water and refrigerant system, increasing product reliability.

Condenser baffle prevents direct impingement of high velocity compressor gas onto the condenser tubes. The baffle eliminates the related vibration and

wear of the tubes and distributes the refrigerant flow evenly over the length of the vessel for improved efficiency.

Closely spaced intermediate support sheets prevent tube sagging and vibration, thereby increasing heat exchanger life.

Refrigerant filter drier isolation valves allow filter replacement without pumping down the chiller, which means less service time and less expense.

FLASC (flash subcooler), located in the bottom of the condenser, increases the refrigeration effect by cooling condensed liquid refrigerant to a lower temperature; resulting in reduced compressor power consumption.

AccuMeter™ system regulates refrigerant flow according to load conditions, providing a liquid seal at all operating conditions and eliminating unintentional hot gas bypass.

Microprocessor control features

Direct digital Product Integrated Control (PIC II) provides unmatched flexibility and functionality. Each unit integrates directly with the Carrier Comfort Network® (CCN) system, providing a system solution to controls applications.

International Chiller Visual Control (ICVC) which can be configured to display units in English or metric, provides unparalleled ease of operation.

A 1¼ VGA 320 x 240 element LCD (liquid crystal display) features 4 menu-specific softkeys. The default display offers all in one glance review of key chiller operation data, simplifying the interaction between chiller and user.

Features include:

- Display of over 125 operating, status, and diagnostic messages for improved user interface
- Monitoring of over 100 functions and conditions to protect the chiller from abnormal conditions
- Modular pull-out/plug-in design, reducing wiring requirements and providing easy installation
- Low-voltage (24 v) design, providing the ultimate assurance of personal safety and control integrity

The display modes include 4 standard languages:

- English
- Chinese
- Japanese
- Korean

Other languages are available.

Automatic capacity override function unloads the compressor whenever key safety limits are approached, increasing unit life.

Chilled water reset can be accomplished manually or automatically from the building management system. Reset saves energy when warmer chilled water can be used.

Demand limiting feature limits the power draw of the chiller during peak loading conditions. When incorporated into the Carrier Comfort Network® building automation system, a red line command holds chillers at their present capacity and prevents any other chillers from starting. If a load shed signal is received, the compressors are unloaded to avoid high demand charges whenever possible.

Ramp loading ensures a smooth pull-down of water loop temperature and prevents a rapid increase in compressor power consumption during the pulldown period.

Automated controls test can be executed prior to start-up to verify that the entire control system is functioning properly.

365-day real time clock feature allows the operator to program a yearly schedule for each week, weekends, and holidays.

Occupancy schedules can be programmed into the controller to ensure that the chiller only operates when cooling is required.

Extensive service menu features include password protection to prevent unauthorized access to the service menu and built-in diagnostic capabilities assist in troubleshooting and recommend proper corrective action for pre-set alarms, resulting in greater operating time.

Alarm file maintains the last 25 time and date-stamped alarm and alert messages in memory; this function reduces troubleshooting time and cost.

Features/Benefits (cont)



Configuration data backup in non-volatile memory provides protection during power failures and eliminates time consuming control reconfiguration.

19XR refrigeration cycle

The compressor continuously draws refrigerant vapor from the cooler at a rate set by the amount of guide vane opening. As the compressor suction reduces the pressure in the cooler, the remaining refrigerant boils at a fairly low temperature (typically 38 to 42 F [3 to 6 C]). The energy required for boiling is obtained from the water flowing through the cooler tubes. With heat energy removed, the water becomes cold enough to use in an air-conditioning circuit or process liquid cooling.

After taking heat from the water, the refrigerant vapor is compressed. Compression adds still more heat energy and the refrigerant is quite warm (typically 98 to 102 F [37 to 40 C]) when it is discharged from the compressor into the condenser.

Relatively cool (typically 65 to 90 F [18 to 32 C]) water flowing into the condenser tubes removes heat from the refrigerant, and the vapor condenses to liquid.

The liquid refrigerant passes through orifices into the FLASC (flash subcooler) chamber. Since the FLASC chamber is at a lower pressure, part of the liquid refrigerant flashes to vapor, thereby cooling the remaining liquid. The FLASC vapor is recondensed on

the tubes which are cooled by entering condenser water. The liquid drains into a float valve chamber between the FLASC chamber and cooler. Here, the AccuMeter™ float valve forms a liquid seal to keep FLASC chamber vapor from entering the cooler. When liquid refrigerant passes through the valve, some of it flashes to vapor in the reduced pressure on the cooler side. In flashing, it removes heat from the remaining liquid. The refrigerant is now at a temperature and pressure at which the cycle began. Refrigerant from the condenser also cools the oil and optional variable speed drive.

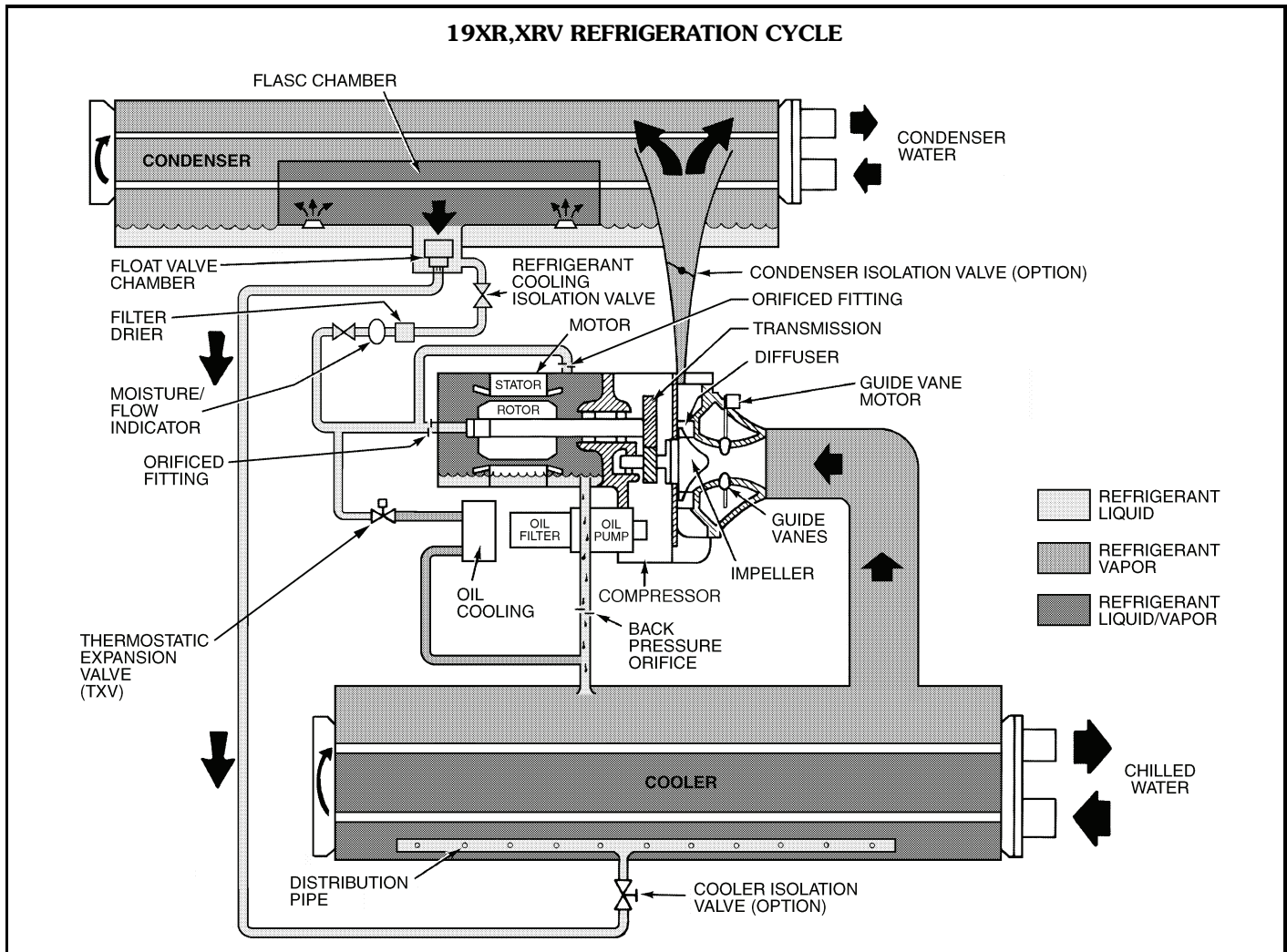

Model number nomenclature

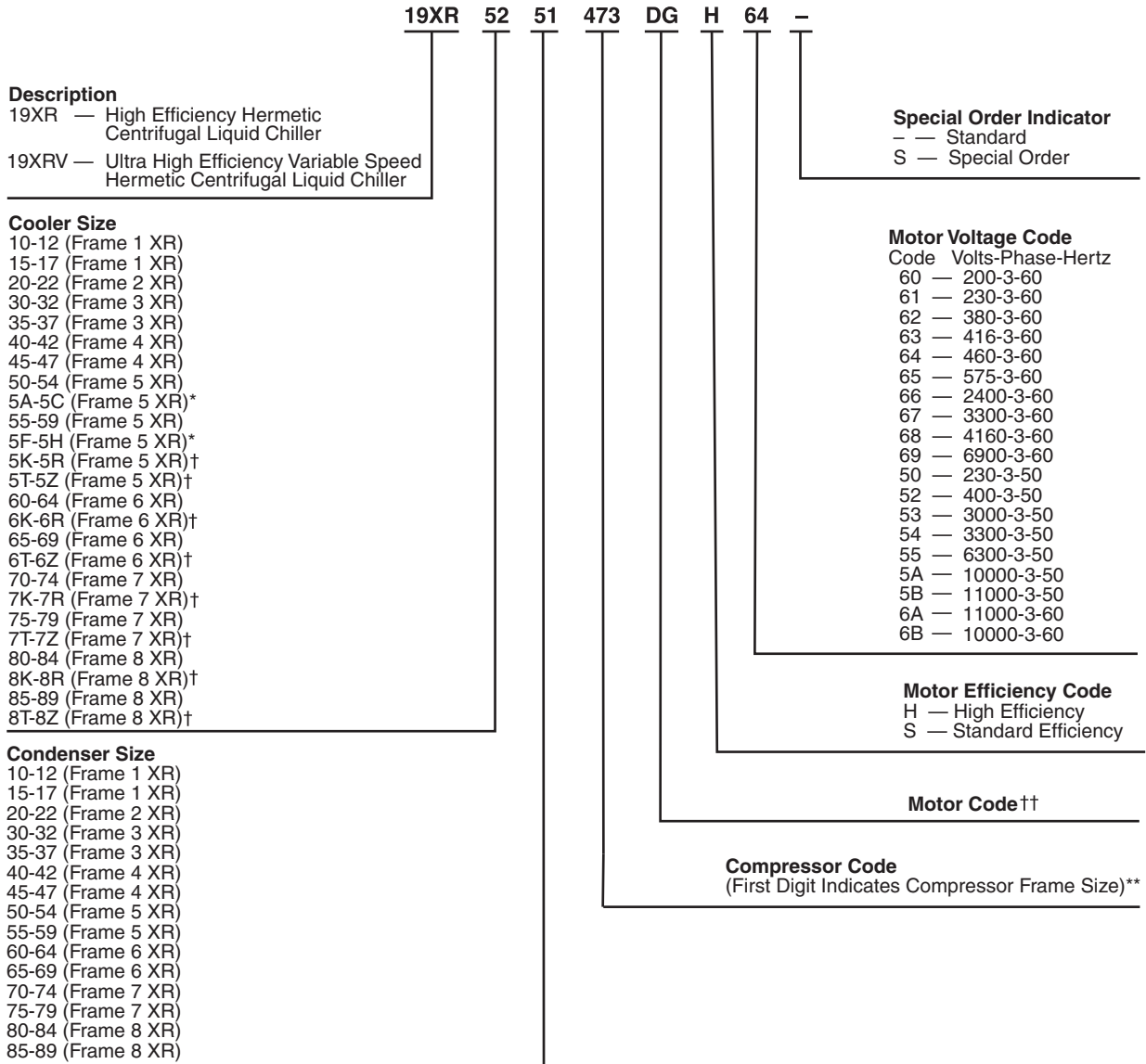

ASME
'U' Stamp



AHRI (Air Conditioning, Heating,
and Refrigeration Institute)
Performance Certified

*Refer to 19XR, 19XRV Computer Selection Program for details on these sizes.

†Refer to the 19XR, 19XRV Computer Selection Program for motor code details.

** Frame sizes with K-R and T-Z are with 1 in. OD evaporator tubing.

SEISMICOMPLIANT*

* Meets IBC 2006, ASCE-7-05, CBC 2007, and OSHPD seismic requirements.

COMPRESSOR COMPONENTS

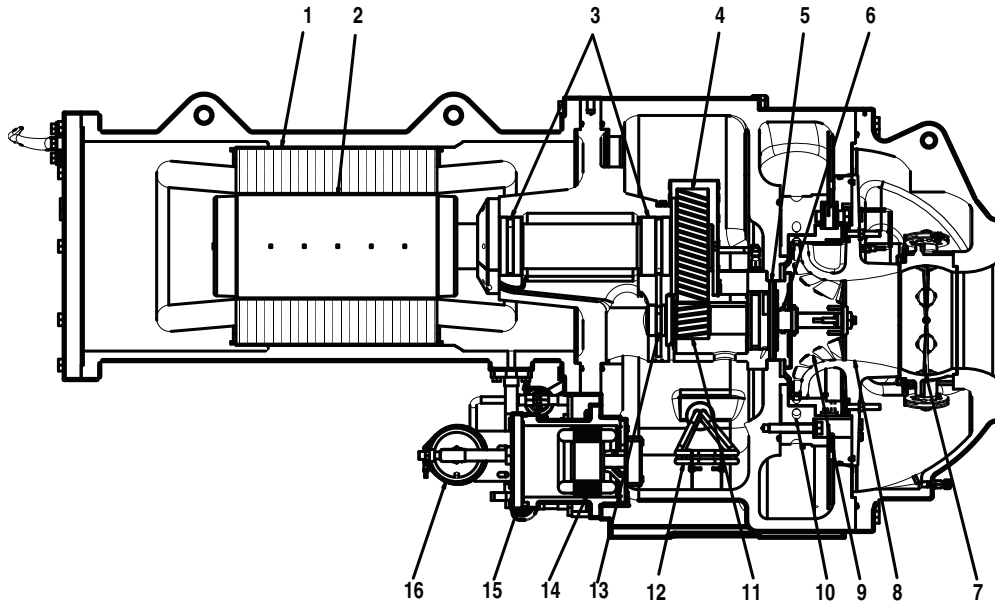

LEGEND

- | | |
|-------------------------------------|-------------------------------|
| 1 — Motor Stator | 9 — Impeller |
| 2 — Motor Rotor | 10 — Pipe Diffuser |
| 3 — Motor Shaft Journal Bearings | 11 — High Speed Pinion Gear |
| 4 — Low Speed Bull Gear | 12 — Oil Heater |
| 5 — High Speed Shaft Thrust Bearing | 13 — High Speed Shaft Bearing |
| 6 — High Speed Shaft Bearing | 14 — Oil Pump Motor |
| 7 — Variable Inlet Guide Vanes | 15 — Oil Pump Cover |
| 8 — Impeller Shroud | 16 — Oil Filter |

19XR,XRV

FRONT VIEW

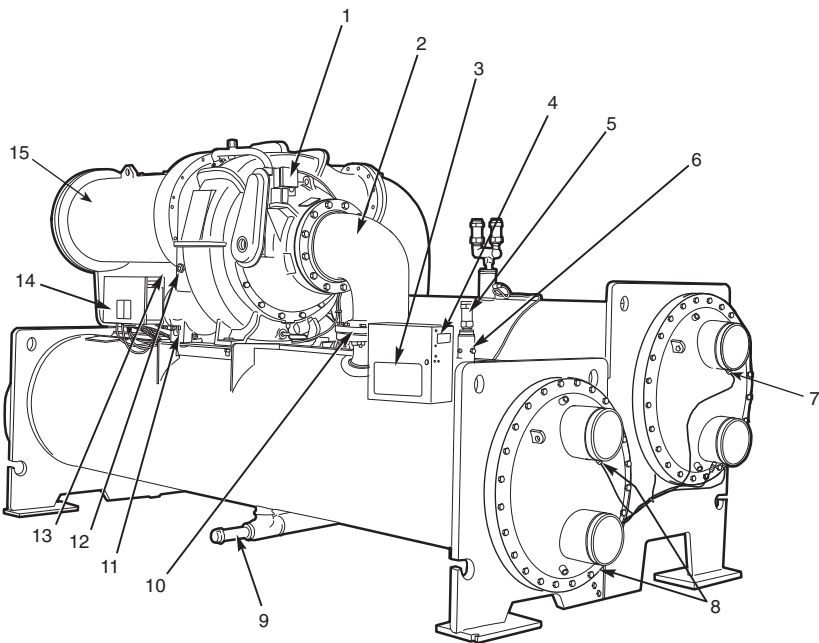

LEGEND

- 1 — Guide Vane Actuator
- 2 — Suction Elbow
- 3 — International Chiller Visual Control (ICVC)
- 4 — Chiller Identification Nameplate
- 5 — Cooler, Auto Reset Relief Valves
- 6 — Cooler Pressure Transducer
- 7 — Condenser In/Out Temperature Thermistors
- 8 — Cooler In/Out Temperature Thermistors
- 9 — Refrigerant Charging Valve
- 10 — Typical Flange Connection
- 11 — Oil Drain Valve
- 12 — Oil Level Sight Glasses
- 13 — Refrigerant Oil Cooler (Hidden)
- 14 — Auxiliary Power Panel
- 15 — Motor Housing

REAR VIEW

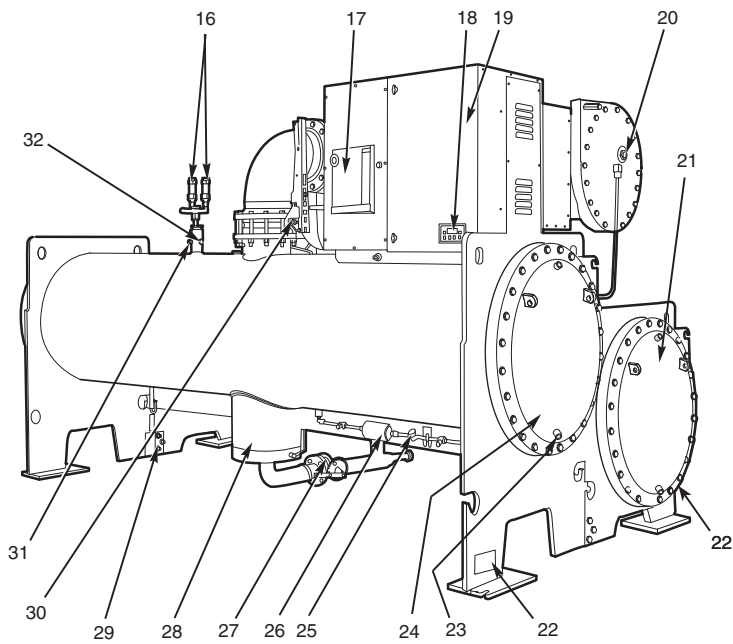

LEGEND

- 16 — Condenser Auto. Reset Relief Valves
- 17 — Motor Circuit Breaker
- 18 — Solid-State Starter Control Display
- 19 — Unit-Mounted Starter or VFD (Optional)
Solid-State Starter Shown
- 20 — Motor Sight Glass
- 21 — Cooler Return-End Waterbox Cover
- 22 — ASME Nameplate (One Hidden)
- 23 — Typical Waterbox Drain Port
- 24 — Condenser Return-End Waterbox Cover
- 25 — Refrigerant Moisture/Flow Indicator
- 26 — Refrigerant Filter/Drier
- 27 — Liquid Line Isolation Valve (Optional)
- 28 — Liquid Float Valve Chamber
- 29 — Vessel Take-Apart Connector
- 30 — Discharge Isolation Valve (Optional)
- 31 — Pumpout Valve
- 32 — Condenser Pressure Transducer

Physical data



19XR COMPRESSOR AND MOTOR WEIGHTS*— STANDARD AND HIGH-EFFICIENCY MOTORS

COMPRESSOR FRAME SIZE 2†

MOTOR CODE	ENGLISH						SI					
	Compressor Weight** (lb)	60 Hz		50 Hz		End Bell Cover Weight (lb)	Compressor Weight** (kg)	60 Hz		50 Hz		End Bell Cover Weight (kg)
		Stator Weight†† (lb)	Rotor Weight (lb)	Stator Weight†† (lb)	Rotor Weight (lb)			Stator Weight†† (kg)	Rotor Weight (kg)	Stator Weight†† (kg)	Rotor Weight (kg)	
STANDARD-EFFICIENCY MOTORS / LOW VOLTAGE (200-575v)												
BDS	2300	900	190	915	205	185	1043	408	86	415	93	84
BES	2300	915	200	965	220	185	1043	415	91	438	100	84
BFS	2300	975	215	1000	230	185	1043	442	98	454	104	84
BGS	2300	1000	230	1060	250	185	1043	454	104	481	113	84
BHS	2300	1030	240	1105	265	185	1043	467	109	501	120	84
BJS	2300	1105	265	—	—	185	1043	501	120	—	—	84
HIGH-EFFICIENCY MOTORS / LOW VOLTAGE (200-575v)												
BDH	2300	1030	240	1030	240	185	1043	467	109	467	109	84
BEH	2300	1070	250	1070	250	185	1043	485	113	485	113	84
BFH	2300	1120	265	1120	265	185	1043	508	120	508	120	84
BGH	2300	1175	290	1175	290	185	1043	533	132	533	132	84
BHH	2300	1175	290	1175	290	185	1043	533	132	533	132	84
BJH	2300	1175	290	—	—	185	1043	533	132	—	—	84
JBH	2300	1003	226	1063	248	185	1043	455	103	482	112	84
JCH	2300	1063	248	1113	263	185	1043	482	112	505	119	84
JDH	2300	1113	263	1149	278	185	1043	505	119	521	126	84
JEH	2300	1149	278	1196	295	185	1043	521	126	542	134	84
JFH	2300	1196	295	—	—	185	1043	542	134	—	—	84

*Total compressor weight is the sum of the compressor aerodynamic components (compressor weight column), stator, rotor, and end bell cover weights.

†Compressor size number is the first digit of the compressor code. See Model Number Nomenclature on page 5.

**Compressor aerodynamic component weight only, motor weight not included. Applicable to standard compressors only. For high lift compressors, contact Carrier Chiller Marketing for weights.

††Stator weight includes the stator and shell.



**19XR COMPRESSOR AND MOTOR WEIGHTS*—
STANDARD AND HIGH-EFFICIENCY MOTORS (cont)**

COMPRESSOR FRAME SIZE 3†

MOTOR CODE	ENGLISH						SI					
	Compressor Weight** (lb)	60 Hz		50 Hz		End Bell Cover Weight (lb)	Compressor Weight** (kg)	60 Hz		50 Hz		End Bell Cover Weight (kg)
		Stator Weight†† (lb)	Rotor Weight (lb)	Stator Weight†† (lb)	Rotor Weight (lb)			Stator Weight†† (kg)	Rotor Weight (kg)	Stator Weight†† (kg)	Rotor Weight (kg)	
STANDARD-EFFICIENCY MOTORS / LOW VOLTAGE (200-575v)												
CBS	2816	1146	219	1188	236	274	1277	520	99	539	107	124
CCS	2816	1171	227	1196	242	274	1277	531	103	542	110	124
CDS	2816	1198	237	1258	255	274	1277	543	108	571	116	124
CES	2816	1207	240	1272	258	274	1277	547	109	577	117	124
CLS	2816	1247	249	1328	273	274	1277	566	113	602	124	124
CMS	2816	1270	257	1353	278	274	1277	576	117	614	126	124
CNS	2816	1321	266	1386	282	274	1277	599	121	629	128	124
CPS	2816	1334	269	1401	287	274	1277	605	122	635	130	124
CQS	2816	1353	276	1408	290	274	1277	614	125	639	132	124
CRS	2816	1259	321	—	—	274	1277	571	146	—	—	124
CRS (380v)	2816	1328	346	—	—	274	1277	602	157	—	—	124
STANDARD-EFFICIENCY MOTORS / MEDIUM VOLTAGE (2400-4160v)												
CBS	2816	1154	236	1160	255	274	1277	523	107	526	116	124
CCS	2816	1182	243	1177	260	274	1277	536	110	534	118	124
CDS	2816	1220	252	1212	270	274	1277	553	114	550	122	124
CES	2816	1253	261	1259	281	274	1277	568	118	571	127	124
CLS	2816	1261	265	1271	284	274	1277	572	120	577	129	124
CMS	2816	1294	273	1318	293	274	1277	587	124	598	133	124
CNS	2816	1314	280	1357	303	274	1277	596	127	616	137	124
CPS	2816	1343	282	1413	308	274	1277	609	128	641	140	124
CQS	2816	1419	300	1522	336	274	1277	644	136	690	152	124
HIGH-EFFICIENCY MOTORS / LOW VOLTAGE (200-575v)												
CBH	2816	1235	239	1290	254	274	1277	560	108	585	115	124
CCH	2816	1260	249	1295	259	274	1277	572	113	587	117	124
CDH	2816	1286	258	1358	273	274	1277	583	117	616	124	124
CEH	2816	1305	265	1377	279	274	1277	592	120	625	127	124
CLH	2816	1324	271	1435	292	274	1277	601	123	651	132	124
CMH	2816	1347	275	1455	298	274	1277	611	125	660	135	124
CNH	2816	1358	278	1467	301	274	1277	616	126	665	137	124
CPH	2816	1401	290	1479	304	274	1277	635	132	671	138	124
CQH	2816	1455	304	1479	304	274	1277	670	138	671	138	124
KBH	2816	1313	276	1353	285	274	1277	596	125	614	129	124
KCH	2816	1353	285	1381	291	274	1277	614	129	626	132	124
KDH	2816	1381	291	1417	307	274	1277	626	132	643	139	124
KEH	2816	1417	307	1441	313	274	1277	643	139	654	142	124
KFH	2816	1441	313	1470	320	274	1277	654	142	667	145	124
KGH	2816	1470	320	1505	333	274	1277	667	145	683	151	124
KHH	2816	1505	333	—	—	274	1277	683	151	—	—	124

*Total compressor weight is the sum of the compressor aerodynamic components (compressor weight column), stator, rotor, and end bell cover weights.

†Compressor size number is the first digit of the compressor code. See Model Number Nomenclature on page 5.

**Compressor aerodynamic component weight only, motor weight not included. Applicable to standard compressors only. For high lift compressors, contact Carrier Chiller Marketing for weights.

††Stator weight includes the stator and shell.

Physical data (cont)



19XR COMPRESSOR AND MOTOR WEIGHTS*— STANDARD AND HIGH-EFFICIENCY MOTORS (cont)

COMPRESSOR FRAME SIZE 3† (cont)

MOTOR CODE	ENGLISH						SI					
	Compressor Weight** (lb)	60 Hz		50 Hz		End Bell Cover Weight (lb)	Compressor Weight** (kg)	60 Hz		50 Hz		End Bell Cover Weight (kg)
		Stator Weight†† (lb)	Rotor Weight (lb)	Stator Weight†† (lb)	Rotor Weight (lb)			Stator Weight†† (kg)	Rotor Weight (kg)	Stator Weight†† (kg)	Rotor Weight (kg)	
HIGH-EFFICIENCY MOTORS / MEDIUM VOLTAGE (2400-4160v)												
CBH	2816	1114	242	1156	255	274	1277	505	110	524	116	124
CCH	2816	1129	247	1163	257	274	1277	512	112	528	117	124
CDH	2816	1155	253	1190	263	274	1277	524	115	540	119	124
CEH	2816	1175	263	1236	276	274	1277	533	119	561	125	124
CLH	2816	1242	280	1305	296	274	1277	563	127	592	134	124
CMH	2816	1321	303	1305	296	274	1277	599	137	592	134	124
CNH	2816	1369	316	1386	316	274	1277	621	143	629	143	124
CPH	2816	1411	329	1386	316	274	1277	640	149	629	143	124
CQH	2816	1411	329	1428	329	274	1277	640	149	648	149	124

*Total compressor weight is the sum of the compressor aerodynamic components (compressor weight column), stator, rotor, and end bell cover weights.

†Compressor size number is the first digit of the compressor code. See Model Number Nomenclature on page 5.

**Compressor aerodynamic component weight only, motor weight not included. Applicable to standard compressors only. For high lift compressors, contact Carrier Chiller Marketing for weights.

††Stator weight includes the stator and shell.



**19XR COMPRESSOR AND MOTOR WEIGHTS*—
STANDARD AND HIGH-EFFICIENCY MOTORS (cont)
COMPRESSOR FRAME SIZE 4†**

MOTOR CODE	ENGLISH						SI					
	Compressor Weight** (lb)	60 Hz		50 Hz		End Bell Cover Weight (lb)	Compressor Weight** (kg)	60 Hz		50 Hz		End Bell Cover Weight (kg)
		Stator Weight†† (lb)	Rotor Weight (lb)	Stator Weight†† (lb)	Rotor Weight (lb)			Stator Weight†† (kg)	Rotor Weight (kg)	Stator Weight†† (kg)	Rotor Weight (kg)	
STANDARD-EFFICIENCY MOTORS / LOW VOLTAGE (200-575v)												
DBS	3425 / 4211	1570	324	1725	347	236	1554 / 1910	712	147	782	157	107
DCS	3425 / 4211	1580	326	1737	352	236	1554 / 1910	717	148	788	160	107
DDS	3425 / 4211	1595	329	1749	357	236	1554 / 1910	723	149	793	162	107
DES	3425 / 4211	1685	345	1762	365	236	1554 / 1910	764	156	799	166	107
DFS	3425 / 4211	1690	348	1801	372	236	1554 / 1910	767	158	817	169	107
DGS	3425 / 4211	1692	352	1858	386	236	1554 / 1910	767	160	843	175	107
DHS	3425 / 4211	1774	366	1904	398	236	1554 / 1910	805	166	864	181	107
DJS	3425 / 4211	—	—	2020	401	318	1554 / 1910	—	—	916	182	142
STANDARD-EFFICIENCY MOTORS / MEDIUM VOLTAGE (2400-4160v)												
DBS	3425 / 4211	1524	296	1637	327	236	1554 / 1910	691	134	743	148	107
DCS	3425 / 4211	1569	307	1685	354	236	1554 / 1910	712	139	764	161	107
DDS	3425 / 4211	1588	313	1713	357	236	1554 / 1910	720	142	777	162	107
DES	3425 / 4211	1613	324	1746	360	236	1554 / 1910	732	147	792	163	107
DFS	3425 / 4211	1675	347	1811	381	236	1554 / 1910	760	157	821	173	107
DGS	3425 / 4211	1704	355	1998	422	236 (60 Hz) 318 (50 Hz)	1554 / 1910	773	161	906	191	107 (60 Hz) 142 (50 Hz)
DHS	3425 / 4211	1737	361	2056	443	236 (60 Hz) 318 (50 Hz)	1554 / 1910	788	164	933	201	107 (60 Hz) 142 (50 Hz)
DJS	3425 / 4211	1769	365	2101	464	236 (60 Hz) 318 (50 Hz)	1554 / 1910	802	166	953	210	107 (60 Hz) 142 (50 Hz)
STANDARD-EFFICIENCY MOTORS / MEDIUM VOLTAGE (6300-6900v)												
DDS	3425 / 4211	1919	423	2069	458	318	1554 / 1910	870	192	938	208	142
DES	3425 / 4211	1939	428	2089	463	318	1554 / 1910	880	194	947	210	142
DFS	3425 / 4211	1989	448	2139	478	318	1554 / 1910	902	203	970	217	142
DGS	3425 / 4211	2054	473	—	—	318	1554 / 1910	932	215	—	—	142
DHS	3425 / 4211	2099	488	—	—	318	1554 / 1910	952	221	—	—	142
DJS	3425 / 4211	2159	508	—	—	318	1554 / 1910	979	230	—	—	142
HIGH-EFFICIENCY MOTORS / LOW VOLTAGE (200-575v)												
DBH	3425 / 4211	1773	406	1827	406	318	1554 / 1910	804	184	829	184	142
DCH	3425 / 4211	1827	406	1827	414	318	1554 / 1910	829	184	829	188	142
DDH	3425 / 4211	1827	414	1881	422	318	1554 / 1910	829	188	853	191	142
DEH	3425 / 4211	1881	422	1881	422	318	1554 / 1910	853	191	853	191	142
DFH	3425 / 4211	1881	439	1963	439	318	1554 / 1910	853	199	890	199	142
DGH	3425 / 4211	1963	455	1963	455	318	1554 / 1910	890	206	890	206	142
DHH	3425 / 4211	1963	455	2050	463	318	1554 / 1910	890	206	930	210	142
DJH	3425 / 4211	—	—	2050	471	318	1554 / 1910	—	—	930	213	142
DKH	3425 / 4211	2050	471	—	—	318	1554 / 1910	930	214	—	—	142

*Total compressor weight is the sum of the compressor aerodynamic components (compressor weight column), stator, rotor, and end bell cover weights.

†Compressor size number is the first digit of the compressor code. See Model Number Nomenclature on page 5.

**Compressor aerodynamic component weight only, motor weight not included. Applicable to standard compressors only. For high lift compressors, contact Carrier Chiller Marketing for weights.

††Stator weight includes the stator and shell.

Physical data (cont)



19XR COMPRESSOR AND MOTOR WEIGHTS*— STANDARD AND HIGH-EFFICIENCY MOTORS (cont) COMPRESSOR FRAME SIZE 4† (cont)

MOTOR CODE	ENGLISH						SI					
	Compressor Weight** (lb)	60 Hz		50 Hz		End Bell Cover Weight (lb)	Compressor Weight*** (kg)	60 Hz		50 Hz		End Bell Cover Weight (kg)
		Stator Weight†† (lb)	Rotor Weight (lb)	Stator Weight†† (lb)	Rotor Weight (lb)			Stator Weight†† (kg)	Rotor Weight (kg)	Stator Weight†† (kg)	Rotor Weight (kg)	
HIGH-EFFICIENCY MOTORS / LOW VOLTAGE (200-575v)												
LBH	3425 / 4211	1873	364	1939	389	318	1554 / 1910	850	165	880	176	144
LCH	3425 / 4211	1939	389	2023	406	318	1554 / 1910	880	176	918	184	144
LDH	3425 / 4211	2023	406	2043	417	318	1554 / 1910	918	184	927	189	144
LEH	3425 / 4211	2043	417	2096	434	318	1554 / 1910	927	189	951	197	144
LFH	3425 / 4211	2096	434	2133	444	318	1554 / 1910	951	197	968	201	144
LGH	3425 / 4211	2133	444	2199	458	318	1554 / 1910	968	201	997	208	144
LHH	3425 / 4211	2199	458	2066	437	318	1554 / 1910	997	208	937	198	144
HIGH-EFFICIENCY MOTORS / MEDIUM VOLTAGE (2400-4160v)												
DBH	3425 / 4211	1950	405	1950	405	318	1554 / 1910	885	184	885	184	144
DCH	3425 / 4211	1950	405	2025	429	318	1554 / 1910	885	184	919	195	144
DDH	3425 / 4211	1950	405	2025	429	318	1554 / 1910	885	184	919	195	144
DEH	3425 / 4211	2025	429	2100	452	318	1554 / 1910	919	195	953	205	144
DFH	3425 / 4211	2025	429	2100	452	318	1554 / 1910	919	195	953	205	144
DGH	3425 / 4211	2100	452	2200	480	318	1554 / 1910	953	205	998	218	144
DHH	3425 / 4211	2100	452	2320	575	318	1554 / 1910	953	205	1052	261	144
DJH	3425 / 4211	2100	452	2320	587	318	1554 / 1910	953	205	1052	266	144
DKH	3425 / 4211	2320	587	—	—	318	1554 / 1910	1052	266	—	—	144
HIGH-EFFICIENCY MOTORS / MEDIUM VOLTAGE (6300-6900v)												
DDH	3425 / 4211	2150	536	2250	546	318	1554 / 1910	975	243	1021	248	144
DEH	3425 / 4211	2150	550	2250	550	318	1554 / 1910	975	249	1021	249	144
DFH	3425 / 4211	2250	575	2380	567	318	1554 / 1910	1021	261	1080	261	144
DGH	3425 / 4211	2250	599	2380	599	318	1554 / 1910	1021	272	1080	272	144
DHH	3425 / 4211	2380	604	2380	604	318	1554 / 1910	1080	274	1080	274	144
DJH	3425 / 4211	2380	614	2380	614	318	1554 / 1910	1080	279	1080	279	144
DKH	3425 / 4211	2380	614	—	—	318	1554 / 1910	1080	279	—	—	144

*Total compressor weight is the sum of the compressor aerodynamic components (compressor weight column), stator, rotor, and end bell cover weights.

†Compressor size number is the first digit of the compressor code. See Model Number Nomenclature on page 5.

**Compressor aerodynamic component weight only, motor weight not included. Applicable to standard compressors only. For high lift compressors, contact Carrier Chiller Marketing for weights.

††Stator weight includes the stator and shell.



**19XR COMPRESSOR AND MOTOR WEIGHTS*—
STANDARD AND HIGH-EFFICIENCY MOTORS (cont)
COMPRESSOR FRAME SIZE 5†**

MOTOR CODE	ENGLISH						SI					
	Compressor Weight** (lb)	60 Hz		50 Hz		End Bell Cover Weight (lb)	Compressor Weight** (kg)	60 Hz		50 Hz		End Bell Cover Weight (kg)
		Stator Weight†† (lb)	Rotor Weight (lb)	Stator Weight†† (lb)	Rotor Weight (lb)			Stator Weight†† (kg)	Rotor Weight (kg)	Stator Weight†† (kg)	Rotor Weight (kg)	
STANDARD-EFFICIENCY MOTORS / LOW VOLTAGE (200-575v)												
EHS	7285	2843	741	2943	775	414	3304	1290	336	1335	352	188
EJS	7285	2826	741	2943	775	414	3304	1281	336	1335	352	188
EKS	7285	2943	775	2997	810	414	3304	1335	352	1359	367	188
ELS	7285	2932	775	2997	810	414	3304	1330	352	1359	367	188
EMS	7285	2986	810	3096	862	414	3304	1354	367	1404	391	188
ENS	7285	2986	810	3203	914	414	3304	1354	367	1453	415	188
EPS	7285	2986	810	3203	914	414	3304	1354	367	1453	415	188
EQS	7285	3013	621	—	—	414	3304	1367	282	—	—	188
STANDARD-EFFICIENCY MOTORS / MEDIUM VOLTAGE (2400-4160v)												
EHS	7285	2744	706	2818	741	414	3304	1245	320	1278	336	188
EJS	7285	2816	741	2892	775	414	3304	1277	336	1312	352	188
EKS	7285	2816	741	2930	775	414	3304	1277	336	1329	352	188
ELS	7285	2808	741	3005	810	414	3304	1274	336	1363	367	188
EMS	7285	2892	775	3005	810	414	3304	1322	352	1363	367	188
ENS	7285	2997	775	3143	879	414	3304	1359	352	1426	399	188
EPS	7285	2967	810	3144	879	414	3304	1346	367	1426	399	188
STANDARD-EFFICIENCY MOTORS / MEDIUM VOLTAGE (6300-6900v)												
EHS	7285	2773	735	2845	769	414	3304	1258	333	1290	349	188
EJS	7285	2855	769	2855	769	414	3304	1295	349	1295	349	188
EKS	7285	2919	803	2919	803	414	3304	1324	364	1324	364	188
ELS	7285	2908	803	3058	871	414	3304	1319	364	1387	395	188
EMS	7285	3029	854	3068	871	414	3304	1374	387	1392	395	188
ENS	7285	3023	854	3281	974	414	3304	1371	387	1488	442	188
EPS	7285	3068	871	3288	974	414	3304	1392	395	1491	442	188
HIGH-EFFICIENCY MOTORS / LOW VOLTAGE (200-575v)												
EHH	7285	2939	776	2995	810	414	3304	1333	352	1359	367	188
EJH	7285	2944	776	3002	810	414	3304	1335	352	1362	367	188
EKH	7285	2992	810	3110	862	414	3304	1357	367	1411	391	188
ELH	7285	2299	810	3099	862	414	3304	1043	367	1406	391	188
EMH	7285	2965	810	3210	914	414	3304	1345	367	1456	415	188
ENH	7285	3015	855	3293	974	414	3304	1368	388	1494	442	188
EPH	7285	3029	855	3289	974	414	3304	1374	388	1492	442	188
EQH	7285	3162	664	—	—	414	3304	1434	301	—	—	188

*Total compressor weight is the sum of the compressor aerodynamic components (compressor weight column), stator, rotor, and end bell cover weights.

†Compressor size number is the first digit of the compressor code. See Model Number Nomenclature on page 5.

**Compressor aerodynamic component weight only, motor weight not included. Applicable to standard compressors only. For high lift compressors, contact Carrier Chiller Marketing for weights.

††Stator weight includes the stator and shell.

Physical data (cont)



19XR COMPRESSOR AND MOTOR WEIGHTS*— STANDARD AND HIGH-EFFICIENCY MOTORS (cont) COMPRESSOR FRAME SIZE 5† (cont)

MOTOR CODE	ENGLISH						SI					
	Compressor Weight** (lb)	60 Hz		50 Hz		End Bell Cover Weight (lb)	Compressor Weight*** (kg)	60 Hz		50 Hz		End Bell Cover Weight (kg)
		Stator Weight†† (lb)	Rotor Weight (lb)	Stator Weight†† (lb)	Rotor Weight (lb)			Stator Weight†† (kg)	Rotor Weight (kg)	Stator Weight†† (kg)	Rotor Weight (kg)	
HIGH-EFFICIENCY MOTORS / LOW VOLTAGE (200-575v)												
MBH	7285	2795	645	2856	665	414	3304	1268	293	1295	302	188
MCH	7285	2873	672	2925	693	414	3304	1303	305	1327	314	188
MDH	7285	2906	684	3013	724	414	3304	1318	310	1367	328	188
MEH	7285	2956	704	3071	737	414	3304	1341	319	1392	334	188
MFH	7285	3034	724	3153	791	414	3304	1376	328	1430	359	188
MGH	7285	3071	737	—	—	414	3304	1393	334	—	—	188
HIGH-EFFICIENCY MOTORS / MEDIUM VOLTAGE (2400-4160v)												
EHH	7285	2939	776	2997	810	414	3304	1333	352	1359	367	188
EJH	7285	2999	810	3108	862	414	3304	1360	367	1410	391	188
EKH	7285	2988	810	3102	862	414	3304	1355	367	1407	391	188
ELH	7285	2981	810	3065	872	414	3304	1352	367	1390	396	188
EMH	7285	3031	855	3077	872	414	3304	1375	388	1396	396	188
ENH	7285	3075	872	3260	974	414	3304	1395	396	1479	442	188
EPH	7285	3081	872	3298	974	414	3304	1398	396	1496	442	188
EQH	7285	3195	657	—	—	414	3304	1449	298	—	—	188
HIGH-EFFICIENCY MOTORS / MEDIUM VOLTAGE (6300-6900v)												
EHH	7285	2998	810	3097	862	414	3304	1360	367	1405	391	188
EJH	7285	3029	855	3100	862	414	3304	1374	388	1406	391	188
EKH	7285	3049	855	3064	872	414	3304	1383	388	1390	396	188
ELH	7285	3068	872	3060	872	414	3304	1390	396	1388	396	188
EMH	7285	—	—	3072	872	414	3304	—	—	1393	396	188
ENH	7285	3075	872	3260	974	414	3304	1395	396	1479	442	188
EPH	7285	3081	872	3288	974	414	3304	1398	396	1491	442	188
EQH	7285	3195	657	—	—	414	3304	1449	298	—	—	188
HIGH-EFFICIENCY MOTORS / HIGH VOLTAGE (10000-11000v)												
MCH	7285	—	—	3956	678	414	3304	—	—	1794	308	188
MDH	7285	—	—	3956	678	414	3304	—	—	1794	308	188
MFH	7285	—	—	4062	719	414	3304	—	—	1842	326	188
MGH	7285	3820	657	—	—	414	3304	1733	298	—	—	188
MHH	7285	3820	657	—	—	414	3304	1733	298	—	—	188

*Total compressor weight is the sum of the compressor aerodynamic components (compressor weight column), stator, rotor, and end bell cover weights.

†Compressor size number is the first digit of the compressor code. See Model Number Nomenclature on page 5.

**Compressor aerodynamic component weight only, motor weight not included. Applicable to standard compressors only. For high lift compressors, contact Carrier Chiller Marketing for weights.

††Stator weight includes the stator and shell.



COMPONENT WEIGHTS

COMPONENT	FRAME 2 COMPRESSOR*		FRAME 3 COMPRESSOR*		FRAME 4 COMPRESSOR*		FRAME 5 COMPRESSOR*	
	lb	kg	lb	kg	lb	kg	lb	kg
Suction Elbow	116	53	185	84	239	108	407	185
Discharge Elbow	100	45	125	57	157	71	325	147
Control Panel†	34	15	34	15	34	15	34	15
Optional Cooler Inlet Isolation Valve	8	4	13	6	20	9	24	11
Optional Discharge Isolation Valve	26	12	46	21	74	34	108	49
Std Tier VFD — 380, 400, and 460-v (335, 445 A)	650	295	650	295	—	—	—	—
Std Tier VFD — 380, 400, and 460-v (485, 550 A)	—	—	1035	469	1035	469	—	—
Std Tier VFD — 380, 400, and 460-v (605, 680, 765, 855, 960, 1070 A)	—	—	1600	726	1600	726	—	—
Std Tier VFD — 380, 400, and 460-v (1275, 1530 A)	—	—	—	—	2800	1270	2800	1270
LiquiFlo™ 2 VFD — 380, 400, and 460-v (405 A / 608 A)	1600	726	1600	726	1600	726	—	—
LiquiFlo 2 VFD — 380, 400, and 460-v (900 A)	—	—	—	—	2800	1270	2800	1270
LiquiFlo 2 VFD — 380, 400, and 460-v (1200 A)	—	—	—	—	2850	1293	2850	1293
LiquiFlo 2 VFD — 575-v (390 A)	2400	1089	2400	1089	—	—	—	—
VFD Shelf	—	—	—	—	1049	476	1049	476

*To determine compressor frame size, refer to 19XR, XRV Computer Selection Program.

†Included in total cooler weight.

Physical data (cont)



19XR HEAT EXCHANGER WEIGHTS — DRIVE END ENTERING COOLER WATER

Code	English						Metric (SI)					
	Dry Rigging Weight (lb)*		Machine Charge				Dry Rigging Weight (kg)*		Machine Charge			
	Cooler Only	Condenser Only	Refrigerant Weight (lb)		Water Weight (lb)		Cooler Only	Condenser Only	Refrigerant Weight (kg)		Water Weight (kg)	
			Cooler	Condenser	Cooler	Condenser			Cooler	Condenser	Cooler	Condenser
10	2707	2704	328	226	283	348	1229	1228	149	103	128	158
11	2777	2772	357	226	309	374	1261	1258	162	103	140	170
12	2848	2857	387	226	335	407	1293	1297	176	103	152	185
15	2969	2984	405	275	327	402	1348	1355	184	125	148	183
16	3054	3068	441	275	359	435	1387	1393	200	125	163	197
17	3141	3173	477	275	391	475	1426	1441	217	125	178	216
20	3407	3373	416	252	402	398	1547	1531	189	114	183	181
21	3555	3540	459	252	456	462	1614	1607	208	114	207	210
22	3711	3704	505	252	514	526	1685	1682	229	114	233	239
30	4071	3694	510	308	464	464	1848	1677	232	140	211	211
31	4253	3899	565	308	531	543	1931	1770	257	140	241	247
32	4445	4100	626	308	601	621	2018	1861	284	140	273	282
35	4343	4606	577	349	511	513	1972	2091	262	158	232	233
36	4551	4840	639	349	587	603	2066	2197	290	158	266	274
37	4769	5069	709	349	667	692	2165	2301	322	158	303	314
40	4908	5039	726	338	863	915	2228	2288	330	153	392	415
41	5078	5232	783	338	930	995	2305	2375	355	153	422	452
42	5226	5424	840	338	990	1074	2373	2462	381	153	449	488
45	5363	5602	821	383	938	998	2435	2543	373	174	426	453
46	5559	5824	874	383	1014	1088	2524	2644	397	174	460	494
47	5730	6044	949	383	1083	1179	2601	2744	431	174	492	535
50	5713	6090	897	446	1101	1225	2594	2765	407	202	500	556
51	5940	6283	974	446	1192	1304	2697	2852	442	202	541	592
52	6083	6464	1021	446	1248	1379	2762	2935	464	202	567	626
53	6141	6529	1010	446	1277	1409	2788	2964	459	202	580	640
54	6192	6591	987	446	1302	1439	2811	2992	448	202	591	653
55	6257	6785	1014	504	1201	1339	2841	3080	460	229	545	608
56	6517	7007	1101	504	1304	1429	2959	3181	500	229	592	649
57	6682	7215	1154	504	1369	1514	3034	3276	524	229	622	687
58	6751	7291	1143	504	1401	1550	3065	3310	519	229	636	704
59	6811	7363	1116	504	1430	1583	3092	3343	507	229	649	719
5A	5124	—	491	—	1023	—	2326	—	223	—	464	—
5B	5177	—	510	—	1050	—	2350	—	232	—	477	—
5C	5243	—	532	—	1079	—	2380	—	242	—	490	—
5F	5577	—	553	—	1113	—	2532	—	251	—	505	—
5G	5640	—	575	—	1143	—	2561	—	261	—	519	—
5H	5716	—	600	—	1176	—	2595	—	272	—	534	—
5K	4993	—	673	—	1067	—	2267	—	306	—	484	—
5L	5090	—	706	—	1118	—	2311	—	321	—	508	—
5M	5165	—	742	—	1162	—	2345	—	337	—	528	—
5P	5041	—	641	—	1111	—	2289	—	291	—	504	—
5Q	5131	—	678	—	1155	—	2329	—	308	—	524	—
5R	5214	—	709	—	1206	—	2367	—	322	—	548	—
5T	5425	—	768	—	1162	—	2463	—	349	—	528	—
5U	5534	—	801	—	1220	—	2512	—	364	—	554	—
5V	5620	—	843	—	1270	—	2551	—	383	—	577	—
5X	5484	—	730	—	1212	—	2490	—	331	—	550	—
5Y	5584	—	769	—	1262	—	2535	—	349	—	573	—
5Z	5678	—	805	—	1320	—	2578	—	365	—	599	—
60	6719	6764	1091	479	1400	1521	3050	3071	495	217	636	691
61	6895	6949	1150	479	1470	1597	3130	3155	522	217	667	725
62	7038	7130	1202	479	1527	1671	3195	3237	546	217	693	759
63	7103	7199	1202	479	1559	1704	3225	3268	546	217	708	774
64	7161	7264	1178	479	1587	1735	3251	3298	535	217	720	788
65	7392	6782	1241	542	1530	1667	3356	3079	563	246	695	757
66	7594	7894	1309	542	1610	1753	3448	3584	594	246	731	796
67	7759	8102	1369	542	1674	1838	3523	3678	622	246	760	834
68	7836	8182	1359	542	1711	1875	3558	3715	617	246	777	851
69	7905	8258	1332	542	1743	1911	3589	3749	605	246	791	868

*Rigging weights are for standard tubes of standard wall thickness (0.025-in. [0.635 mm] wall).

NOTES:

1. Cooler includes the control panel (ICVC), suction elbow, and 1/2 the distribution piping weight.
2. Condenser includes float valve and sump, discharge elbow, and 1/2 the distribution piping weight.
3. For special tubes refer to the 19XR/XRV Computer Selection Program.
4. All weights for standard 2-pass NIH (nozzle-in-head) design.



19XR HEAT EXCHANGER WEIGHTS — DRIVE END ENTERING COOLER WATER (cont)

Code	English						Metric (SI)					
	Dry Rigging Weight (lb)		Machine Charge				Dry Rigging Weight (kg)		Machine Charge			
	Cooler Only	Condenser Only	Refrigerant Weight (lb)		Water Weight (lb)		Cooler Only	Condenser Only	Refrigerant Weight (kg)		Water Weight (kg)	
			Cooler	Condenser	Cooler	Condenser			Cooler	Condenser	Cooler	Condenser
6K	5716	—	760	—	1291	—	2595	—	345	—	586	—
6L	5804	—	797	—	1341	—	2635	—	362	—	609	—
6M	5894	—	828	—	1399	—	2676	—	376	—	635	—
6P	5768	—	725	—	1338	—	2619	—	329	—	607	—
6Q	5852	—	764	—	1385	—	2657	—	347	—	629	—
6R	5938	—	798	—	1439	—	2696	—	362	—	653	—
6T	6230	—	863	—	1405	—	2828	—	392	—	638	—
6U	6330	—	905	—	1462	—	2874	—	411	—	664	—
6V	6433	—	941	—	1528	—	2921	—	427	—	694	—
6X	6293	—	823	—	1459	—	2857	—	374	—	662	—
6Y	6388	—	868	—	1512	—	2900	—	394	—	686	—
6Z	6487	—	906	—	1574	—	2945	—	411	—	715	—
70	9942	10786	1409	840	2008	2225	4514	4897	640	381	912	1010
71	10330	11211	1539	840	2164	2389	4690	5090	699	381	982	1085
72	10632	11622	1646	840	2286	2548	4827	5276	747	381	1038	1157
73	10715	11737	1622	840	2328	2604	4865	5329	736	381	1057	1182
74	10790	11775	1584	840	2366	2622	4899	5346	719	381	1074	1190
75	10840	11859	1599	950	2183	2431	4921	5384	726	431	991	1104
76	11289	12345	1747	950	2361	2619	5125	5605	793	431	1072	1189
77	11638	12814	1869	950	2501	2801	5284	5818	849	431	1135	1272
78	11738	12949	1849	950	2548	2864	5329	5879	839	431	1157	1300
79	11828	12994	1806	950	2592	2885	5370	5899	820	431	1177	1310
7K	8728	—	1047	—	1948	—	3963	—	475	—	884	—
7L	8959	—	1132	—	2094	—	4067	—	514	—	951	—
7M	9161	—	1214	—	2229	—	4159	—	551	—	1012	—
7P	8792	—	1002	—	2010	—	3992	—	455	—	913	—
7Q	9023	—	1087	—	2156	—	4096	—	493	—	979	—
7R	9229	—	1167	—	2295	—	4190	—	530	—	1042	—
7T	9431	—	1194	—	2115	—	4282	—	542	—	960	—
7U	9698	—	1292	—	2282	—	4403	—	587	—	1036	—
7V	9932	—	1403	—	2436	—	4509	—	637	—	1106	—
7X	9510	—	1142	—	2185	—	4318	—	518	—	992	—
7Y	9777	—	1240	—	2352	—	4439	—	563	—	1068	—
7Z	10016	—	1347	—	2511	—	4547	—	612	—	1140	—
80	12664	12753	1700	836	2726	2977	5749	5790	772	380	1238	1352
81	12998	13149	1812	836	2863	3143	5901	5970	823	380	1300	1427
82	13347	13545	1928	836	3005	3309	6060	6149	875	380	1364	1502
83	13437	13872	1877	836	3053	3476	6100	6298	852	380	1386	1578
84	13523	14217	1840	836	3099	3651	6139	6455	835	380	1407	1658
85	13804	14008	1927	945	2951	3238	6267	6360	875	429	1340	1470
86	14191	14465	2054	945	3108	3428	6443	6567	933	429	1411	1556
87	14597	14923	2186	945	3271	3618	6627	6775	992	429	1485	1643
88	14705	15311	2142	945	3325	3608	6676	6951	972	429	1510	1638
89	14808	15721	2099	945	3378	4009	6723	7137	953	429	1534	1820
8K	11153	—	1385	—	2760	—	5063	—	629	—	1253	—
8L	11400	—	1484	—	2926	—	5176	—	674	—	1328	—
8M	11650	—	1589	—	3088	—	5289	—	721	—	1402	—
8P	11219	—	1334	—	2830	—	5093	—	606	—	1285	—
8Q	11470	—	1430	—	2999	—	5207	—	649	—	1362	—
8R	11719	—	1535	—	3161	—	5320	—	697	—	1435	—
8T	12069	—	1580	—	2991	—	5479	—	717	—	1358	—
8U	12357	—	1694	—	3180	—	5610	—	769	—	1444	—
8V	12645	—	1814	—	3365	—	5741	—	824	—	1528	—
8X	12152	—	1522	—	3070	—	5517	—	691	—	1394	—
8Y	12444	—	1632	—	3264	—	5650	—	741	—	1482	—
8Z	12733	—	1752	—	3448	—	5781	—	795	—	1565	—

*Rigging weights are for standard tubes of standard wall thickness (0.025-in. [0.635 mm] wall).

NOTES:

1. Cooler includes the control panel (ICVC), suction elbow, and 1/2 the distribution piping weight.
2. Condenser includes float valve and sump, discharge elbow, and 1/2 the distribution piping weight.
3. For special tubes refer to the 19XR/XRV Computer Selection Program.
4. All weights for standard 2-pass NIH (nozzle-in-head) design.

Physical data (cont)



19XR HEAT EXCHANGER WEIGHTS— COMPRESSOR END ENTERING COOLER WATER

Code	English						Metric (SI)					
	Dry Rigging Weight (lb)*		Machine Charge				Dry Rigging Weight (kg)*		Machine Charge			
	Cooler Only	Condenser Only	Refrigerant Weight (lb)		Water Weight (lb)		Cooler Only	Condenser Only	Refrigerant Weight (kg)		Water Weight (kg)	
			Cooler	Condenser	Cooler	Condenser			Cooler	Condenser	Cooler	Condenser
10	2707	2704	290	200	283	348	1228	1227	132	91	128	158
11	2777	2772	310	200	309	374	1260	1257	141	91	140	170
12	2848	2857	330	200	335	407	1292	1296	150	91	152	185
15	2968	2984	320	250	327	402	1346	1354	145	113	148	182
16	3054	3068	340	250	359	435	1385	1392	154	113	163	197
17	3141	3173	370	250	391	475	1425	1439	168	113	177	215
20	3407	3373	345	225	402	398	1545	1530	156	102	182	181
21	3555	3540	385	225	456	462	1613	1606	175	102	207	210
22	3711	3704	435	225	514	526	1683	1680	197	102	233	239
30	4071	3694	350	260	464	464	1847	1676	159	118	210	210
31	4253	3899	420	260	531	543	1929	1769	191	118	241	246
32	4445	4100	490	260	601	621	2016	1860	222	118	273	282
35	4343	4606	400	310	511	513	1970	2089	181	141	232	233
36	4551	4840	480	310	587	603	2064	2195	218	141	266	274
37	4769	5069	550	310	667	692	2163	2299	249	141	303	314
40	4908	5039	560	280	863	915	2226	2286	254	127	391	415
41	5078	5232	630	280	930	995	2303	2373	286	127	422	451
42	5226	5424	690	280	990	1074	2370	2460	313	127	449	487
45	5363	5602	640	330	938	998	2433	2541	290	150	425	453
46	5559	5824	720	330	1014	1088	2522	2642	327	150	460	494
47	5730	6044	790	330	1083	1179	2599	2742	358	150	491	535
50	5713	6090	750	400	1101	1225	2591	2762	340	181	499	556
51	5940	6283	840	400	1192	1304	2694	2850	381	181	541	591
52	6083	6464	900	400	1248	1379	2759	2932	408	181	566	626
53	6141	6529	900	400	1277	1409	2788	2964	409	182	580	640
54	6192	6591	900	400	1302	1439	2811	2992	409	182	591	653
55	6257	6785	870	490	1201	1339	2838	3078	395	222	545	607
56	6517	7007	940	490	1304	1429	2956	3178	426	222	591	648
57	6682	7215	980	490	1369	1514	3031	3273	445	222	621	687
58	6751	7291	980	490	1401	1550	3065	3310	445	222	636	704
59	6811	7363	980	490	1430	1583	3092	3343	445	222	649	719
5A	5124	—	500	—	1023	—	2324	—	227	—	464	—
5B	5177	—	520	—	1050	—	2348	—	236	—	476	—
5C	5243	—	550	—	1079	—	2378	—	249	—	489	—
5F	5577	—	550	—	1113	—	2530	—	249	—	505	—
5G	5640	—	570	—	1143	—	2558	—	259	—	518	—
5H	5716	—	600	—	1176	—	2593	—	272	—	533	—
5K	4993	—	673	—	1067	—	2267	—	306	—	484	—
5L	5090	—	706	—	1118	—	2311	—	321	—	508	—
5M	5165	—	742	—	1162	—	2345	—	337	—	528	—
5P	5041	—	641	—	1111	—	2289	—	291	—	504	—
5Q	5131	—	678	—	1155	—	2329	—	308	—	524	—
5R	5214	—	709	—	1206	—	2367	—	322	—	548	—
5T	5425	—	768	—	1162	—	2463	—	349	—	528	—
5U	5534	—	801	—	1220	—	2512	—	364	—	554	—
5V	5620	—	843	—	1270	—	2551	—	383	—	577	—
5X	5484	—	730	—	1212	—	2490	—	331	—	550	—
5Y	5584	—	769	—	1262	—	2535	—	349	—	573	—
5Z	5678	—	805	—	1320	—	2578	—	365	—	599	—
60	6719	6764	940	420	1400	1521	3048	3068	426	191	635	690
61	6895	6949	980	420	1470	1597	3128	3152	445	191	667	724
62	7038	7130	1020	420	1527	1671	3192	3234	463	191	693	758
63	7103	7199	1020	420	1559	1714	3225	3268	463	191	708	778
64	7161	7264	1020	420	1587	1735	3251	3298	463	191	720	788
65	7392	7682	1020	510	1530	1667	3353	3484	463	231	694	756
66	7594	7894	1060	510	1610	1753	3445	3581	481	231	730	795
67	7759	8102	1090	510	1674	1838	3519	3675	494	231	759	834
68	7836	8182	1090	510	1711	1875	3558	3715	495	232	777	851
69	7905	8258	1090	510	1743	1911	3589	3749	495	232	791	868

*Rigging weights are for standard tubes of standard wall thickness (0.025-in. [0.635 mm] wall).

NOTES:

- Cooler includes the control panel (ICVC), suction elbow, and 1/2 the distribution piping weight.
- Condenser includes float valve and sump, discharge elbow, and 1/2 the distribution piping weight.
- For special tubes refer to the 19XR/XRV Computer Selection Program.
- All weights for standard 2-pass NIH (nozzle-in-head) design.



19XR HEAT EXCHANGER WEIGHTS — COMPRESSOR END ENTERING COOLER WATER (cont)

Code	English						Metric (SI)					
	Dry Rigging Weight (lb)		Machine Charge				Dry Rigging Weight (kg)		Machine Charge			
	Cooler Only	Condenser Only	Refrigerant Weight (lb)		Water Weight (lb)		Cooler Only	Condenser Only	Refrigerant Weight (kg)		Water Weight (kg)	
			Cooler	Condenser	Cooler	Condenser			Cooler	Condenser	Cooler	Condenser
6K	5716	—	760	—	1291	—	2595	—	345	—	586	—
6L	5804	—	797	—	1341	—	2635	—	362	—	609	—
6M	5894	—	828	—	1399	—	2676	—	376	—	635	—
6P	5768	—	725	—	1338	—	2619	—	329	—	607	—
6Q	5852	—	764	—	1385	—	2657	—	347	—	629	—
6R	5938	—	798	—	1439	—	2696	—	362	—	653	—
6T	6230	—	863	—	1405	—	2828	—	392	—	638	—
6U	6330	—	905	—	1462	—	2874	—	411	—	664	—
6V	6433	—	941	—	1528	—	2921	—	427	—	694	—
6X	6293	—	823	—	1459	—	2857	—	374	—	662	—
6Y	6388	—	868	—	1512	—	2900	—	394	—	686	—
6Z	6487	—	906	—	1574	—	2945	—	411	—	715	—
70	9942	10782	1220	780	2008	2223	4510	4891	553	354	911	1008
71	10330	11211	1340	780	2164	2389	4686	5085	608	354	982	1084
72	10632	11612	1440	780	2286	2544	4823	5267	653	354	1037	1154
73	10715	11737	1440	780	2328	2604	4865	5329	654	354	1057	1182
74	10790	11775	1440	780	2366	2622	4899	5346	654	354	1074	1190
75	10840	11854	1365	925	2183	2429	4917	5377	619	420	990	1102
76	11289	12345	1505	925	2361	2619	5121	5600	683	420	1071	1188
77	11638	12803	1625	925	2501	2796	5279	5807	737	420	1134	1268
78	11738	12949	1625	925	2548	2864	5329	5879	738	420	1157	1300
79	11828	12994	1625	925	2592	2885	5370	5899	738	420	1177	1310
7K	8728	—	1047	—	1948	—	3963	—	475	—	884	—
7L	8959	—	1132	—	2094	—	4067	—	514	—	951	—
7M	9161	—	1214	—	2229	—	4159	—	551	—	1012	—
7P	8792	—	1002	—	2010	—	3992	—	455	—	913	—
7Q	9023	—	1087	—	2156	—	4096	—	493	—	979	—
7R	9229	—	1167	—	2295	—	4190	—	530	—	1042	—
7T	9431	—	1194	—	2115	—	4282	—	542	—	960	—
7U	9698	—	1292	—	2282	—	4403	—	587	—	1036	—
7V	9932	—	1403	—	2436	—	4509	—	637	—	1106	—
7X	9510	—	1142	—	2185	—	4318	—	518	—	992	—
7Y	9777	—	1240	—	2352	—	4439	—	563	—	1068	—
7Z	10016	—	1347	—	2511	—	4547	—	612	—	1140	—
80	12664	12753	1500	720	2726	2977	5744	5785	680	327	1236	1350
81	12998	13149	1620	720	2863	3143	5896	5964	735	327	1299	1426
82	13347	13545	1730	720	3005	3309	6054	6144	785	327	1363	1501
83	13437	13872	1730	720	3053	3476	6100	6298	785	327	1386	1578
84	13523	14217	1730	720	3099	3651	6139	6455	785	327	1407	1658
85	13804	14008	1690	860	2951	3238	6261	6354	767	390	1339	1469
86	14191	14465	1820	860	3108	3428	6437	6561	826	390	1410	1555
87	14597	14923	1940	860	3271	3618	6621	6769	880	390	1484	1641
88	14705	15311	1940	860	3325	3808	6676	6951	881	390	1510	1729
89	14808	15721	1940	860	3378	4009	6723	7137	881	390	1534	1820
8K	11153	—	1385	—	2760	—	5063	—	629	—	1253	—
8L	11400	—	1484	—	2926	—	5176	—	674	—	1328	—
8M	11650	—	1589	—	3088	—	5289	—	721	—	1402	—
8P	11219	—	1334	—	2830	—	5093	—	606	—	1285	—
8Q	11470	—	1430	—	2999	—	5207	—	649	—	1362	—
8R	11719	—	1535	—	3161	—	5320	—	697	—	1435	—
8T	12069	—	1580	—	2991	—	5479	—	717	—	1358	—
8U	12357	—	1694	—	3180	—	5610	—	769	—	1444	—
8V	12645	—	1814	—	3365	—	5741	—	824	—	1528	—
8X	12152	—	1522	—	3070	—	5517	—	691	—	1394	—
8Y	12444	—	1632	—	3264	—	5650	—	741	—	1482	—
8Z	12733	—	1752	—	3448	—	5781	—	795	—	1565	—

*Rigging weights are for standard tubes of standard wall thickness (0.025-in. [0.635 mm] wall).

NOTES:

1. Cooler includes the control panel (ICVC), suction elbow, and 1/2 the distribution piping weight.
2. Condenser includes float valve and sump, discharge elbow, and 1/2 the distribution piping weight.
3. For special tubes refer to the 19XR/XRV Computer Selection Program.
4. All weights for standard 2-pass NIH (nozzle-in-head) design.

Physical data (cont)



ADDITIONAL WEIGHTS FOR 19XR MARINE WATERBOXES*

150 psig (1034 kPa) MARINE WATERBOXES

FRAME	NUMBER OF PASSES	ENGLISH (lb)				SI (kg)			
		Cooler		Condenser		Cooler		Condenser	
		Rigging Wgt	Water Wgt	Rigging Wgt	Water Wgt	Rigging Wgt	Water Wgt	Rigging Wgt	Water Wgt
1	1&3	N/A	N/A	N/A	N/A	N/A	N/A	N/A	N/A
	2	N/A	N/A	N/A	N/A	N/A	N/A	N/A	N/A
2 and 3	1&3	730	700	N/A	N/A	331	318	N/A	N/A
	2	365	350	365	350	166	159	166	159
4	1&3	1888	908	N/A	N/A	856	412	N/A	N/A
	2	944	452	989	452	428	205	449	205
5	1&3	2445	1019	N/A	N/A	1109	462	N/A	N/A
	2	1223	510	1195	499	555	231	542	226
6	1&3	2860	1155	N/A	N/A	1297	524	N/A	N/A
	2	1430	578	1443	578	649	262	655	262
7	1&3	3970	2579	N/A	N/A	1801	1170	N/A	N/A
	2	1720	1290	1561	1025	780	585	708	465
8	1&3	5048	3033	N/A	N/A	2290	1376	N/A	N/A
	2	2182	1517	1751	1172	990	688	794	532

300 psig (2068 kPa) MARINE WATERBOXES

FRAME	NUMBER OF PASSES	ENGLISH (lb)				SI (kg)			
		Cooler		Condenser		Cooler		Condenser	
		Rigging Wgt	Water Wgt	Rigging Wgt	Water Wgt	Rigging Wgt	Water Wgt	Rigging Wgt	Water Wgt
1	1&3	N/A	N/A	N/A	N/A	N/A	N/A	N/A	N/A
	2	N/A	N/A	N/A	N/A	N/A	N/A	N/A	N/A
2 and 3	1&3	860	700	N/A	N/A	390	318	N/A	N/A
	2	430	350	430	350	195	159	195	159
4	1&3	2162	908	N/A	N/A	981	412	N/A	N/A
	2	1552	393	1641	393	704	178	744	178
5	1&3	2655	1019	N/A	N/A	1204	462	N/A	N/A
	2	1965	439	1909	418	891	199	866	190
6	1&3	3330	1155	N/A	N/A	1510	524	N/A	N/A
	2	2425	480	2451	480	1100	218	1112	218
7	1&3	5294	2579	N/A	N/A	2401	1170	N/A	N/A
	2	4140	1219	4652	784	1878	553	2110	356
8	1&3	6222	3033	N/A	N/A	2822	1376	N/A	N/A
	2	4952	1343	4559	783	2246	609	2068	355

*Add to cooler and condenser weights for total weights. Condenser weights may be found in the 19XR Heat Exchanger Weights table on pages 16-19. The first digit of the heat exchanger code (first column) is the heat exchanger frame size.



**19XR WATERBOX COVER WEIGHTS — ENGLISH (lb)
FRAMES 1, 2, AND 3; COOLER**

WATERBOX DESCRIPTION	COOLER					
	Frame 1		Frame 2		Frame 3	
	Standard Nozzles	Flanged	Standard Nozzles	Flanged	Standard Nozzles	Flanged
NIH, 1 Pass Cover, 150 psig	177	204	320	350	320	350
NIH, 2 Pass Cover, 150 psig	185	218	320	350	320	350
NIH, 3 Pass Cover, 150 psig	180	196	310	340	310	340
NIH Plain End Cover, 150 psig	136	136	300	300	300	300
MWB End Cover, 150 psig	—	—	300	300	300	300
MWB Return Cover, 150 psig	—	—	243	243	243	243
NIH, 1 Pass Cover, 300 psig	248	301	411	486	411	486
NIH, 2 Pass Cover, 300 psig	255	324	411	518	411	518
NIH, 3 Pass Cover, 300 psig	253	288	433	468	433	468
NIH Plain End Cover, 300 psig	175	175	400	400	400	400
MWB End Cover, 300 psig	—	—	400	400	400	400
MWB Return Cover, 300 psig	—	—	445	445	445	445

LEGEND

NIH — Nozzle-in-Head
MWB — Marine Waterbox

NOTE: Weight for NIH 2-pass cover, 150 psig, is included in the heat exchanger weights shown on pages 16-19.

FRAMES 1, 2, AND 3; CONDENSER

WATERBOX DESCRIPTION	CONDENSER					
	Frame 1		Frame 2		Frame 3	
	Standard Nozzles	Flanged	Standard Nozzles	Flanged	Standard Nozzles	Flanged
NIH, 1 Pass Cover, 150 psig	177	204	320	350	320	350
NIH, 2 Pass Cover, 150 psig	185	218	320	350	320	350
NIH, 3 Pass Cover, 150 psig	180	196	310	310	310	340
NIH Plain End Cover, 150 psig	136	136	300	300	300	300
MWB End Cover, 150 psig	—	—	300	300	300	300
MWB Return Cover, 150 psig	—	—	225	225	225	225
NIH, 1 Pass Cover, 300 psig	248	301	411	486	411	486
NIH, 2 Pass Cover, 300 psig	255	324	411	518	411	518
NIH, 3 Pass Cover, 300 psig	253	288	433	468	433	468
NIH Plain End Cover, 300 psig	175	175	400	400	400	400
MWB End Cover, 300 psig	—	—	400	400	400	400
MWB Return Cover, 300 psig	—	—	359	359	359	359

LEGEND

NIH — Nozzle-in-Head
MWB — Marine Waterbox

NOTE: Weight for NIH 2-pass cover, 150 psig, is included in the heat exchanger weights shown on pages 16-19.

Physical data (cont)



19XR WATERBOX COVER WEIGHTS — ENGLISH (lb) (cont) FRAMES 4, 5, AND 6; COOLER

WATERBOX DESCRIPTION	COOLER					
	Frame 4		Frame 5		Frame 6	
	Standard Nozzles	Flanged	Standard Nozzles	Flanged	Standard Nozzles	Flanged
NIH, 1 Pass Cover, 150 psig	148	185	168	229	187	223
NIH, 2 Pass Cover, 150 psig	202	256	224	298	257	330
NIH, 3 Pass Cover, 150 psig	473	489	629	655	817	843
NIH Plain End Cover, 150 psig	138	138	154	154	172	172
MWB End Cover, 150 psig	317	317	393	393	503	503
MWB Return Cover, 150 psig	138	138	154	154	172	172
NIH, 1 Pass Cover, 300 psig	593	668	764	839	959	1035
NIH, 2 Pass Cover, 300 psig	594	700	761	878	923	1074
NIH, 3 Pass Cover, 300 psig	621	656	795	838	980	1031
NIH/MWB End Cover, 300 psig	569	569	713	713	913	913

LEGEND

NIH — Nozzle-in-Head
MWB — Marine Waterbox

NOTE: Weight for NIH 2-pass cover, 150 psig, is included in the heat exchanger weights shown on pages 16-19.

FRAMES 4, 5, AND 6; CONDENSER

WATERBOX DESCRIPTION	CONDENSER					
	Frame 4		Frame 5		Frame 6	
	Standard Nozzles	Flanged	Standard Nozzles	Flanged	Standard Nozzles	Flanged
NIH, 1 Pass Cover, 150 psig	148	185	168	229	187	223
NIH, 2 Pass Cover, 150 psig	202	256	224	298	257	330
NIH, 3 Pass Cover, 150 psig	473	489	629	655	817	843
NIH Plain End Cover, 150 psig	138	138	154	154	172	172
MWB End Cover, 150 psig	317	317	393	393	503	503
MWB Return Cover, 150 psig	138	138	154	154	172	172
NIH, 1 Pass Cover, 300 psig	593	668	764	839	959	1035
NIH, 2 Pass Cover, 300 psig	594	700	761	878	923	1074
NIH, 3 Pass Cover, 300 psig	621	656	795	838	980	1031
NIH/MWB End Cover, 300 psig	569	569	713	713	913	913

LEGEND

NIH — Nozzle-in-Head
MWB — Marine Waterbox

NOTE: Weight for NIH 2-pass cover, 150 psig, is included in the heat exchanger weights shown on pages 16-19.



**19XR WATERBOX COVER WEIGHTS — ENGLISH (lb) (cont)
FRAMES 7 AND 8; COOLER**

WATERBOX DESCRIPTION	COOLER			
	FRAME 7		FRAME 8	
	Standard Nozzles	Flanged	Standard Nozzles	Flanged
NIH, 1 Pass Cover, 150 psig	329	441	417	494
NIH, 2 Pass Cover, 150 psig	426	541	531	685
NIH, 3 Pass Cover, 150 psig	1202	1239	1568	1625
NIH Plain End Cover, 150 psig	315	315	404	404
MWB End Cover, 150 psig	789	789	1339	1339
MWB Return Cover, 150 psig	315	315	404	404
NIH, 1 Pass Cover, 300 psig	1636	1801	2265	2529
NIH, 2 Pass Cover, 300 psig	1585	1825	2170	2499
NIH, 3 Pass Cover, 300 psig	1660	1741	2273	2436
NIH/MWB End Cover, 300 psig	1451	1451	1923	1923

LEGEND

NIH — Nozzle-in-Head
MWB — Marine Waterbox

NOTE: Weight for NIH 2-pass cover, 150 psig, is included in the heat exchanger weights shown on pages 16-19.

FRAMES 7 AND 8; CONDENSER

WATERBOX DESCRIPTION	CONDENSER			
	Frame 7		Frame 8	
	Standard Nozzles	Flanged	Standard Nozzles	Flanged
NIH, 1 Pass Cover, 150 psig	329	441	417	494
NIH, 2 Pass Cover, 150 psig	426	541	531	685
NIH, 3 Pass Cover, 150 psig	1113	1171	1438	1497
NIH Plain End Cover, 150 psig	315	315	404	404
MWB End Cover, 150 psig	703	703	898	898
Bolt On MWB End Cover, 150 psig	700	700	1307	1307
MWB Return Cover, 150 psig	315	315	404	404
NIH, 1 Pass Cover, 300 psig	1472	1633	1860	2015
NIH, 2 Pass Cover, 300 psig	1410	1644	1735	2044
NIH, 3 Pass Cover, 300 psig	1495	1613	1883	1995
NIH/MWB End Cover, 300 psig	1440	1440	1635	1635

LEGEND

NIH — Nozzle-in-Head
MWB — Marine Waterbox

NOTE: Weight for NIH 2-pass cover, 150 psig, is included in the heat exchanger weights shown on pages 16-19.

Physical data (cont)



19XR WATERBOX COVER WEIGHTS — SI (kg) FRAMES 1, 2, 3; COOLER

WATERBOX DESCRIPTION	COOLER					
	FRAME 1		FRAME 2		FRAME 3	
	Standard Nozzles	Flanged	Standard Nozzles	Flanged	Standard Nozzles	Flanged
NIH, 1 Pass Cover, 1034 kPa	80	92	145	159	145	159
NIH, 2 Pass Cover, 1034 kPa	84	99	145	159	145	159
NIH, 3 Pass Cover, 1034 kPa	82	88	141	154	141	154
NIH Plain End Cover, 1034 kPa	61	62	136	136	136	136
MWB End Cover, 1034 kPa	—	—	136	136	136	136
MWB Return Cover, 1034 kPa	—	—	110	110	110	110
NIH, 1 Pass Cover, 2068 kPa	112	137	186	220	186	220
NIH, 2 Pass Cover, 2068 kPa	116	147	186	235	186	235
NIH, 3 Pass Cover, 2068 kPa	115	131	196	212	196	212
NIH Plain End Cover, 2068 kPa	79	79	181	181	181	181
MWB End Cover, 2068 kPa	—	—	181	181	181	181
MWB Return Cover, 2068 kPa	—	—	202	202	202	202

LEGEND

NIH — Nozzle-in-Head
MWB — Marine Waterbox

NOTE: Weight for NIH 2-pass cover, 1034 kPa, is included in the heat exchanger weights shown on pages 16-19.

FRAMES 1, 2, 3; CONDENSER

WATERBOX DESCRIPTION	CONDENSER					
	Frame 1		Frame 2		Frame 3	
	Standard Nozzles	Flanged	Standard Nozzles	Flanged	Standard Nozzles	Flanged
NIH, 1 Pass Cover, 1034 kPa	80	92	145	159	145	159
NIH, 2 Pass Cover, 1034 kPa	84	99	145	159	145	159
NIH, 3 Pass Cover, 1034 kPa	82	88	141	154	141	154
NIH Plain End Cover, 1034 kPa	61	62	136	136	136	136
MWB End Cover, 1034 kPa	—	—	136	136	136	136
MWB Return Cover, 1034 kPa	—	—	102	102	102	102
NIH, 1 Pass Cover, 2068 kPa	112	137	186	220	186	220
NIH, 2 Pass Cover, 2068 kPa	116	147	186	235	186	235
NIH, 3 Pass Cover, 2068 kPa	115	131	196	212	196	212
NIH Plain End Cover, 2068 kPa	79	79	181	181	181	181
MWB End Cover, 2068 kPa	—	—	181	181	181	181
MWB Return Cover, 2068 kPa	—	—	163	163	163	163

LEGEND

NIH — Nozzle-in-Head
MWB — Marine Waterbox

NOTE: Weight for NIH 2-pass cover, 1034 kPa, is included in the heat exchanger weights shown on pages 16-19.



19XR WATERBOX COVER WEIGHTS — SI (kg) (cont)
FRAMES 4, 5, 6; COOLER

WATERBOX DESCRIPTION	COOLER					
	Frame 4		Frame 5		Frame 6	
	Standard Nozzles	Flanged	Standard Nozzles	Flanged	Standard Nozzles	Flanged
NIH, 1 Pass Cover, 1034 kPa	67	84	76	104	85	101
NIH, 2 Pass Cover, 1034 kPa	92	116	102	135	117	150
NIH, 3 Pass Cover, 1034 kPa	215	222	285	297	371	382
NIH Plain End Cover, 1034 kPa	63	63	70	70	78	78
MWB End Cover, 1034 kPa	144	144	178	178	228	228
MWB Return Cover, 1034 kPa	63	63	70	70	78	78
NIH, 1 Pass Cover, 2068 kPa	269	303	347	381	435	479
NIH, 2 Pass Cover, 2068 kPa	269	318	345	393	419	487
NIH, 3 Pass Cover, 2068 kPa	282	298	361	376	495	468
NIH/MWB End Cover, 2068 kPa	258	258	323	298	414	414

LEGEND

NIH — Nozzle-in-Head
MWB — Marine Waterbox

NOTE: Weight for NIH 2-pass cover, 1034 kPa, is included in the heat exchanger weights shown on pages 16-19.

FRAMES 4, 5, 6; CONDENSER

WATERBOX DESCRIPTION	CONDENSER					
	Frame 4		Frame 5		Frame 6	
	Standard Nozzles	Flanged	Standard Nozzles	Flanged	Standard Nozzles	Flanged
NIH, 1 Pass Cover, 1034 kPa	67	84	76	104	85	101
NIH, 2 Pass Cover, 1034 kPa	92	116	102	135	117	150
NIH, 3 Pass Cover, 1034 kPa	215	222	285	297	371	382
NIH Plain End Cover, 1034 kPa	63	63	70	70	78	78
MWB End Cover, 1034 kPa	144	144	178	178	228	228
MWB Return Cover, 1034 kPa	63	63	70	70	78	78
NIH, 1 Pass Cover, 2068 kPa	269	303	347	381	435	469
NIH, 2 Pass Cover, 2068 kPa	269	318	345	393	419	487
NIH, 3 Pass Cover, 2068 kPa	282	298	361	376	445	468
NIH/MWB End Cover, 2068 kPa	258	258	323	298	414	414

LEGEND

NIH — Nozzle-in-Head
MWB — Marine Waterbox

NOTE: Weight for NIH 2-pass cover, 1034 kPa, is included in the heat exchanger weights shown on pages 16-19.

Physical data (cont)



19XR WATERBOX COVER WEIGHTS — SI (kg) (cont) FRAMES 7 AND 8; COOLER

WATERBOX DESCRIPTION	COOLER			
	Frame 7		Frame 8	
	Standard Nozzles	Flanged	Standard Nozzles	Flanged
NIH, 1 Pass Cover, 1034 kPa	149	200	189	224
NIH, 2 Pass Cover, 1034 kPa	193	245	241	311
NIH, 3 Pass Cover, 1034 kPa	545	562	711	737
NIH Plain End Cover, 1034 kPa	143	143	183	183
MWB End Cover, 1034 kPa	358	358	607	607
MWB Return Cover, 1034 kPa	143	143	183	183
NIH, 1 Pass Cover, 2068 kPa	742	817	1027	1147
NIH, 2 Pass Cover, 2068 kPa	719	828	984	1134
NIH, 3 Pass Cover, 2068 kPa	753	790	1031	1105
NIH/MWB End Cover, 2068 kPa	658	658	872	872

LEGEND

NIH — Nozzle-in-Head
MWB — Marine Waterbox

NOTE: Weight for NIH 2-pass cover, 1034 kPa, is included in the heat exchanger weights shown on pages 16-19.

FRAMES 7 AND 8; CONDENSER

WATERBOX DESCRIPTION	CONDENSER			
	FRAME 7		FRAME 8	
	Standard Nozzles	Flanged	Standard Nozzles	Flanged
NIH, 1 Pass Cover, 1034 kPa	149	200	189	224
NIH, 2 Pass Cover, 1034 kPa	193	245	241	311
NIH, 3 Pass Cover, 1034 kPa	505	531	652	679
NIH Plain End Cover, 1034 kPa	143	143	183	183
MWB End Cover, 1034 kPa	319	319	407	407
Bolt On MWB End Cover, 1034 kPa	318	318	593	593
MWB Return Cover, 1034 kPa	143	143	183	183
NIH, 1 Pass Cover, 2068 kPa	668	741	844	914
NIH, 2 Pass Cover, 2068 kPa	640	746	787	927
NIH, 3 Pass Cover, 2068 kPa	678	732	859	905
NIH/MWB End Cover, 2068 kPa	653	653	742	742

LEGEND

NIH — Nozzle-in-Head
MWB — Marine Waterbox

NOTE: Weight for NIH 2-pass cover, 1034 kPa, is included in the heat exchanger weights shown on pages 16-19.

Options and accessories



ITEM	OPTION*	ACCESSORY†
Unit-Mounted Variable Frequency Drive	X	X
Shipped Factory Charged with Refrigerant	X	
One, 2, or 3 Pass Cooler or Condenser Waterside Construction	X	
Hot Gas Bypass	X	
Thermal Insulation (Except Waterbox Covers)	X	
Nozzle-in Head Waterbox, 300 psig (2068 kPa)	X	
Marine Waterboxes, 150 psig (1034 kPa)**	X	
Marine Waterboxes, 300 psig (2068 kPa), ASME Certified**	X	
Marine Bolt-On Waterboxes for Condenser, 150 psig (1034 kPa) with Cupronickel or Titanium-Clad Tubesheets (Available on Condenser Frame Sizes 3 to 8 Only)**	X	
Flanged Cooler and/or Condenser Waterbox Nozzles††	X	
Waterbox Hinges	X	
Zinc Anodes	X	
0.028 or 0.035 in. (0.711 or 0.889 mm) Internally/Externally Enhanced Copper Tubing — Cooler/Condenser	X	
0.028 or 0.035 in. (0.711 or 0.889 mm) Smooth Bore/Externally Enhanced Copper Tubing — Cooler/Condenser	X	
0.028 or 0.035 in. (0.711 or 0.889 mm) Smooth Bore/Externally Enhanced Cupronickel Tubing — Condenser	X	
0.028 or 0.035 in. (0.711 or 0.889 mm) Internally/Externally Enhanced Cupronickel Tubing — Condenser	X	
0.025 or 0.028 in. (0.635 or 0.711 mm) Wall Tubes, Titanium, Internally Enhanced, Condenser	X	
0.025 or 0.028 in. (0.635 or 0.711 mm) Wall Tubes, Titanium, Smooth Bore, Condenser	X	
Unit-Mounted Low-Voltage Wye-Delta or Solid-State Starters	X	
Export Crating	X	
Customer Factory Performance Testing	X	
Extended Warranty (North America only)	X	
Service Contract	X	
Refrigerant Isolation Valves	X	
Unit-Mounted Pumpout Unit	X	
Seismic Kit	X	
Stand-Alone Pumpout Unit		X
Separate Storage Tank and Pumpout Unit		X
Soleplate Package		X
Sensor Package		X
BACnet*** Communications	X	
LonWorks††† Carrier Translator		X
Discharge Line Sound Reduction Kit		X
Acoustical Sound Insulation Kit		X
Spring Isolator Kit		X

*Factory Installed.

†Field Installed.

**Optional marine waterboxes are available for 19XR heat exchanger frames 2-8 only. Standard waterboxes for both 19XR and 19XRV chillers are nozzle-in-head type, 150 psig (1034 kPa).

††Standard waterbox nozzles are victaulic type. Flanged nozzles are available as an option with either nozzle-in-head type waterboxes or marine waterboxes.

***Sponsored by ASHRAE (American Society of Heating, Refrigerating, and Air Conditioning Engineers).

†††Registered trademark of Echelon corporation.

Options and accessories (cont)



UNIT-MOUNTED STARTER AND VFD FEATURES AND OPTIONS*

ITEM	WYE-DELTA	SOLID STATE	VFD
ISM	S	N/A	S
Branch Oil Pump Circuit Breaker	S	S	S
3 kva Controls/Oil Heater Transformer with Branch Circuit Breaker	S	S	S
Microprocessor Based Overload Trip Protection	S	S	S
Main Power Disconnect (Non-Fused Type) with Shunt Trip	S	N/A	N/A
Main Power Circuit Breaker with Shunt Trip	N/A	S	S
High Interrupt Capacity Main Circuit Breaker with Shunt Trip	O	O	O
Phase Loss/Reversal Imbalance Protection	S	S	S
Three Phase Ground Fault Protection†	S	S	S
Integral SCR Bypass Contactor	N/A	S	N/A
Three-Phase Digital Ammeter	S	S	N/A
Three-Phase Analog Ammeter with Switch	O	O	N/A
Three-Phase Digital Voltmeter	S	S	N/A
Three-Phase Analog Voltmeter with Switch	O	O	N/A
Three-Phase Over/Under Voltage Protection	S	S	S
Power Factor Digital Display	S	S	S
Frequency Digital Display	S	S	S
Digital Watt Display	O	O	O
Digital Watt Hour Display	O	O	O
Digital Power Factor Display	O	O	O
Demand Kilowatt Display	O	O	O
Lightning Arrestor and Surge Capacitor Package	O	O	N/A
Power Factor Correction Capacitors	O	O	N/A
Transient Voltage Surge Suppressor	N/A	N/A	S

LEGEND

ISM — Integrated Starter Module
N/A — Not Applicable
O — Optional
S — Standard Feature
SCR — Silicon Control Rectifier
VFD — Variable Frequency Drive

*Refer to the E-Cat Chiller builder software for all VFD options, as some options may not be available for all VFD models.

†Low voltage: phase to phase and phase to ground. Medium voltage: one phase to phase.

Dimensions



19XR DIMENSIONS (Nozzle-in-Head Waterbox)

HEAT EXCHANGER SIZE	A (Length, with Nozzle-in-Head Waterbox)						19XR B (Width)		19XR C (Height)		19XRV B (Width)		19XRV C (Height)
	1-Pass		2-Pass*		3-Pass		ft-in.	mm	ft-in.	mm	ft-in.	mm	
	ft-in.	mm	ft-in.	mm	ft-in.	mm							
10 to 12	11- 11	3632	11- 4	3464	11- 11	3632	5- 2 ⁷ / ₈	1597	6- 1 ¹ / ₄	1861	5- 2 ⁷ / ₈	1597	
15 to 17	14- 2 ¹ / ₂	4331	13- 7 ¹ / ₂	4163	14- 2 ¹ / ₂	4331	5- 2 ⁷ / ₈	1597	6- 1 ¹ / ₄	1861	5- 2 ⁷ / ₈	1597	
20 to 22	12- 0 ¹ / ₂	3670	11- 5 ¹ / ₈	3483	12- 0 ¹ / ₂	3670	5- 6 ⁷ / ₁₆	1688	6- 3 ¹ / ₄	1911	5- 6 ⁷ / ₁₆	1688	
30 to 32†	14- 4	4369	13- 8 ⁵ / ₈	4182	14- 4	4369	5- 7 ³ / ₁₆	1707	6- 9 ⁵ / ₈	2073	5- 6 ⁷ / ₁₆	1688	
30 to 32**	14- 4	4369	13- 8 ⁵ / ₈	4182	14- 4	4369	5- 7 ³ / ₁₆	1707	6- 9 ⁵ / ₈	2073	5- 6 ¹ / ₈	1680	
35 to 37†	16- 0 ¹ / ₂	4889	15- 5 ¹ / ₈	4703	16- 0 ¹ / ₂	4889	5- 7 ³ / ₁₆	1707	6- 9 ⁵ / ₈	2073	5- 6 ⁷ / ₁₆	1688	
35 to 37**	16- 0 ¹ / ₂	4889	15- 5 ¹ / ₈	4703	16- 0 ¹ / ₂	4889	5- 7 ³ / ₁₆	1707	6- 9 ⁵ / ₈	2073	5- 6 ¹ / ₈	1680	
40 to 42	14- 10	4521	14- 3 ⁵ / ₈	4360	14- 6 ³ / ₄	4439	6- 3 ¹ / ₈	1908	7- 0 ³ / ₄	2153	6- 2	1880	
45 to 47	16- 6 ¹ / ₂	5042	16- 0 ¹ / ₈	4880	16- 3 ¹ / ₄	4959	6- 3 ¹ / ₈	1908	7- 0 ³ / ₄	2153	6- 2	1880	
50 to 52**	14- 11	4546	14- 5	4395	14- 7 ¹ / ₄	4451	6- 8 ⁷ / ₈	2054	7- 2 ³ / ₈	2194	6- 6 ¹ / ₂	1994	
50 to 54, 5K to 5R††	14- 11	4546	14- 5	4395	14- 7 ¹ / ₄	4451	6- 8 ⁷ / ₈	2054	7- 2 ³ / ₈	2194	6- 7 ⁷ / ₈	2029	
5A to 5C	14- 11	4546	14- 5	4395	14- 7 ¹ / ₄	4451	6- 8 ⁷ / ₈	2054	7- 2 ³ / ₈	2194	6- 8 ⁷ / ₈	2054	
55 to 57**	16- 7 ¹ / ₂	5067	16- 1 ¹ / ₂	4915	16- 3 ³ / ₄	4972	6- 8 ⁷ / ₈	2054	7- 2 ³ / ₈	2194	6- 6 ¹ / ₂	1994	
55 to 59, 5T to 5Z††	16- 7 ¹ / ₂	5067	16- 1 ¹ / ₂	4915	16- 3 ³ / ₄	4972	6- 8 ⁷ / ₈	2054	7- 2 ³ / ₈	2194	6- 7 ⁷ / ₈	2029	
5F to 5H	16- 7 ¹ / ₂	5067	16- 1 ¹ / ₂	4915	16- 3 ³ / ₄	4972	6- 8 ⁷ / ₈	2054	7- 2 ³ / ₈	2194	6- 8 ⁷ / ₈	2054	
60 to 64, 6K to 6R	15- 0	4572	14- 5 ³ / ₄	4413	14- 7 ³ / ₄	4464	6- 0 ⁵ / ₈	2124	7- 4 ³ / ₈	2245	6- 10 ⁵ / ₈	2124	
65 to 69, 6T to 6Z	16- 8 ¹ / ₂	5093	16- 2 ¹ / ₄	4934	16- 4 ¹ / ₄	4985	6- 0 ⁵ / ₈	2124	7- 4 ³ / ₈	2245	6- 10 ⁵ / ₈	2124	
70 to 74, 7K to 7R††	17- 1 ¹ / ₂	5219	16- 11 ¹ / ₂	5169	16- 10	5131	7- 11 ¹ / ₂	2426	9- 9 ¹ / ₂	2972	9- 1 ³ / ₈	2778	
70 to 74, 7K to 7R***	17- 1 ¹ / ₂	5219	16- 11 ¹ / ₂	5169	16- 10	5131	7- 11 ¹ / ₂	2426	9- 9 ¹ / ₂	2972	9- 3 ⁵ / ₈	2835	
75 to 79, 7T to 7Z	19- 1 ¹ / ₂	5829	18- 11 ¹ / ₂	5779	18- 10	5740	7- 11 ¹ / ₂	2426	9- 9 ¹ / ₂	2972	9- 3 ⁵ / ₈	2835	
80 to 84, 8K to 8R	17- 4 ¹ / ₂	5296	17- 1	5207	16- 10 ¹ / ₂	5143	8- 10 ³ / ₄	2711	9- 11 ¹ / ₄	3029	10- 0 ⁹ / ₁₆	3063	
85 to 89, 8T to 8Z	19- 4 ¹ / ₂	5905	19- 1	5817	18- 10 ¹ / ₂	5753	8- 10 ³ / ₄	2711	9- 11 ¹ / ₄	3029	10- 0 ⁹ / ₁₆	3063	

See Note 7

*Assumes both cooler and condenser nozzles on same end of chiller.

†Compressor frame size 2.

**Compressor frame size 3.

††Compressor frame size 4.

***Compressor frame size 5.

NOTES:

1. Service access should be provided per American Society of Heating, Refrigerating, and Air Conditioning Engineers (ASHRAE) 15, latest edition, National Fire Protection Association (NFPA) 70, and local safety code.
2. Allow at least 3 ft (915 mm) overhead clearance for service rigging for frame 2-4 compressor. Overhead clearance for service rigging frame 5 compressor should be 5 ft (1524 mm).

3. Dimensions are approximate. Certified drawings available upon request.

4. Marine waterboxes may add 6 in. (152 mm) to the width of the machine. See certified drawings for details.

5. 'A' length dimensions shown are for standard 150 psig (1034 kPa) design and victaulic connections. The 300 psig (2068 kPa) design and/or flanges will add length. See certified drawings.

6. Not all waterbox/pass combinations are available with unit-mounted VFD. Check selection program and Drawing Manager for availability.

7. 19XRV heights can vary depending on the configuration. Check 19XRV certified drawings for height information.

Dimensions (cont)

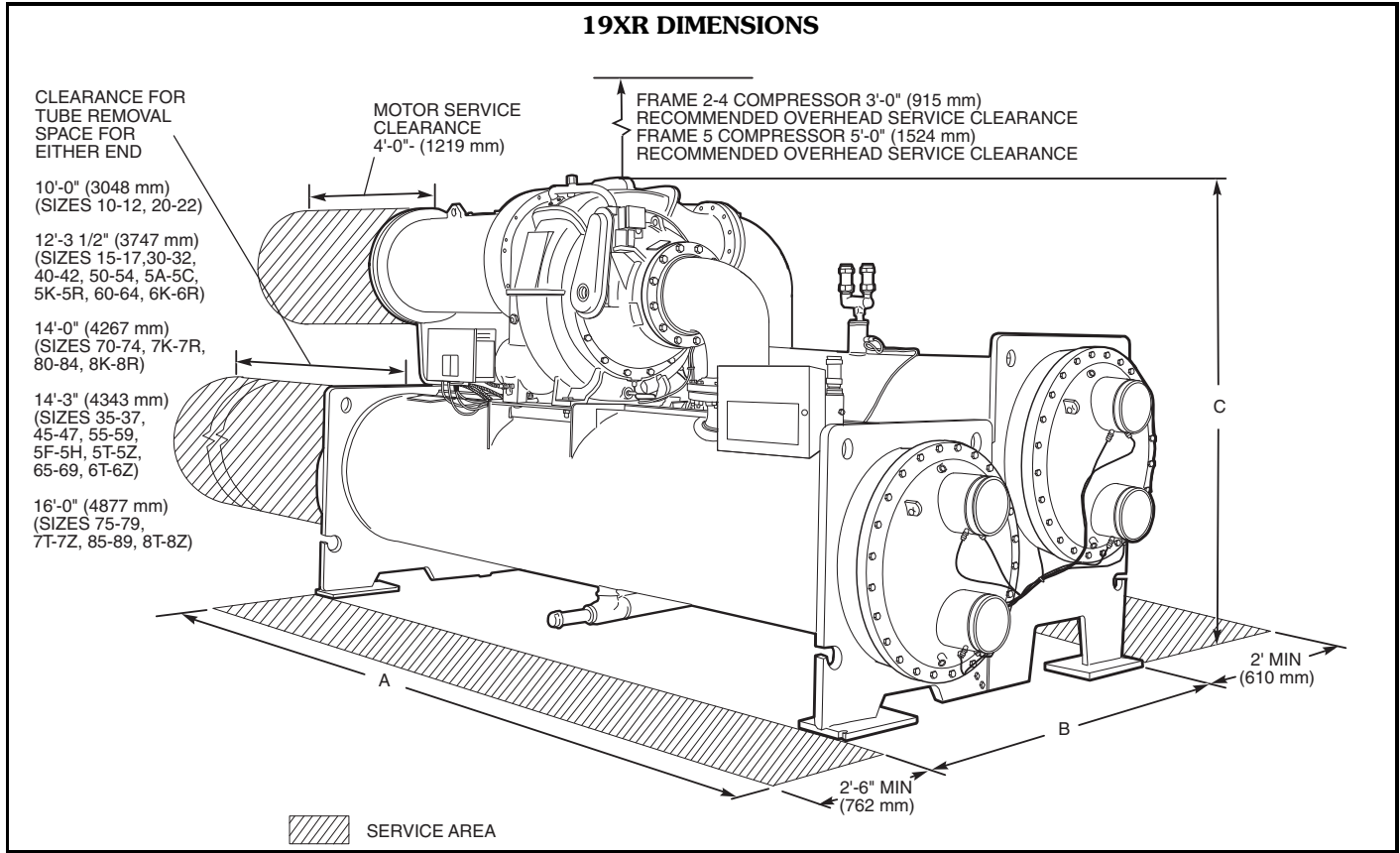

19XR DIMENSIONS (Marine Waterbox)

HEAT EXCHANGER SIZE	A (Length, Marine Waterbox)				19XR B WIDTH		19XR V B WIDTH		19XR, XRV C HEIGHT
	2-Pass*		1 or 3-Pass†		ft-in.	mm	ft-in.	mm	
	ft-in.	mm	ft-in.	mm					
10 to 12	NA	NA	NA	NA	NA	NA	NA	NA	See Note 6
15 to 17	NA	NA	NA	NA	NA	NA	NA	NA	
20 to 22	12- 5 1/2	3797	14- 1 1/4	4299	6- 1 1/16	1856	6- 1 1/16	1856	
30 to 32	14- 9	4496	16- 4 3/4	4997	6- 1 1/16	1856	6- 1 1/16	1856	
35 to 37	16- 5 1/2	5017	18- 1 1/4	5518	6- 1 1/16	1856	6- 1 1/16	1856	
40 to 42	15- 2 3/4	4642	16- 8 1/4	5086	6- 3 1/4	1911	6- 3 1/4	1911	
45 to 47	16- 11 1/4	5163	18- 4 3/4	5607	6- 3 1/4	1911	6- 3 1/4	1911	
50 to 54, 5K to 5R	15- 3 1/2	4661	16- 8 1/2	5093	6- 8 7/8	2054	6- 8 7/8	2054	
5A to 5C	15- 3 1/2	4661	16- 8 1/2	5093	6- 8 7/8	2054	6- 8 7/8	2054	
55 to 59, 5T to 5Z	17- 0	5182	18- 5	5613	6- 8 7/8	2054	6- 8 7/8	2054	
5F to 5H	17- 0	5182	18- 5	5613	6- 8 7/8	2054	6- 8 7/8	2054	
60 to 64, 6K to 6R	15- 4 1/8	4677	16- 8 3/4	5099	6- 11 3/4	2127	6- 11 3/4	2127	
65 to 69, 6T to 6Z	17- 0 5/8	5197	18- 5 1/4	5620	6- 11 3/4	2127	6- 11 3/4	2127	
70 to 74, 7K to 7R	18- 3 5/8	5579	19- 9 3/4	6039	8- 8 1/8	2645	9- 6 3/8	2905	
75 to 79, 7T to 7Z	20- 3 5/8	6188	21- 9 3/4	6649	8- 8 1/8	2645	9- 6 3/8	2905	
80 to 84, 8K to 8R	18- 4	5583	19- 10 1/2	6058	9- 5 5/8	2886	10- 5	3175	
85 to 89, 8T to 8Z	20- 4	6198	21- 10 1/2	6668	9- 5 5/8	2886	10- 5	3175	

*Assumes both cooler and condenser nozzles on same end of chiller.
†1 or 3-pass length applies if cooler is a 1 or 3-pass design.

NOTES:

- Service access should be provided per American Society of Heating, Refrigerating, and Air Conditioning Engineers (ASHRAE) 15, latest edition, National Fire Protection Association (NFPA) 70, and local safety code.
- Allow at least 3 ft (915 mm) overhead clearance for service rigging for frame 2-4 compressor. Overhead clearance for service rigging frame 5 compressor should be 5 ft (1524 mm).
- Dimensions are approximate. Certified drawings available upon request.

- Marine waterboxes may add 6 in. (152 mm) to the width of the machine. See certified drawings for details.
- 'A' length dimensions shown are for standard 150 psig (1034 kPa) design and victaulic connections. The 300 psig (2068 kPa) design and/or flanges will add length. See certified drawings.
- 19XR, XRV heights can vary depending on the configuration. Check 19XR, XRV certified drawings for height information.
- Not all waterbox/pass combinations are available with unit-mounted VFD (variable frequency drive). Check selection program for availability.



NOZZLE SIZE

FRAME SIZE	NOZZLE SIZE (in.) (Nominal Pipe Size)					
	Cooler			Condenser		
	1-Pass	2-Pass	3-Pass	1-Pass	2-Pass	3-Pass
1	8	6	6	8	6	6
2	10	8	6	10	8	6
3	10	8	6	10	8	6
4	10	8	6	10	8	6
5	10	8	6	10	10	8
6	10	10	8	10	10	8
7	14	12	10	14	12	12
8	14	14	12	14	14	12

Selection procedure

Compressor motor controllers

Compressor motors, as well as controls and accessories, require the use of starting equipment systems specifically designed for 19XR or 19XRV chillers. Consult your local Carrier representative regarding design information for the selection of starters.

Capacitors/power factors

Power factor considerations may indicate use of capacitors. Properly sized capacitors improve power factors, especially at part load. The 19XR Computer Selection program can select the proper capacitor size required for the application.

Electrical data

AUXILIARY RATINGS (Oil Pump) (3 Phase, 50/60 Hz)

ITEM	AVERAGE kW	MIN/MAX MOTOR VOLTAGE/ FREQUENCY V-Ph-Hz	INRUSH kva	SEALED kva
OIL PUMP	1.35	200/240-3-60	9.34	1.65
		380/480-3-60	9.09	1.60
		507/619-3-60	24.38	2.08
	1.50	220/240-3-50	11.15	1.93
		346/440-3-50	8.30	1.76

NOTE: FLA (Full Load Amps) = Sealed kva • 1000/√3 • volts
LRA (Locked Rotor Amps) = Inrush kva • 1000/√3 • volts

AUXILIARY RATINGS (Controls, Oil Sump Heater)

ITEM	POWER SUPPLY	SEALED kva	AVERAGE WATTS
CONTROLS	24-vac	0.12	120
OIL SUMP HEATER V-Ph-Hz	115 V or 230 V, Single Phase, 50 or 60 Hz	—	1500 (Frame 2 Compressor)
			1800 (Frame 3,4 Compressor)
			2200 (Frame 5 Compressor)
			1800 (Frame 4 SRD Only)

LEGEND

SRD — Split Ring Diffuser

NOTES:

1. Oil sump heater only operates when the compressor is off.
2. Power to oil heater/controls must be on circuits that can provide continuous service when the compressor is disconnected.

Controls



Microprocessor controls

Microprocessor controls provide the safety, interlock, capacity control, and indications necessary to operate the chiller in a safe and efficient manner.

Control system

The microprocessor control on each Carrier centrifugal system is factory mounted, wired, and tested to ensure machine protection and efficient capacity control. In addition, the program logic ensures proper starting, stopping, and recycling of the chiller and provides a communication link to the Carrier Comfort Network® (CCN) system.

Features

Control system

- Component test and diagnostic check
- Programmable recycle allows chiller to recycle at optimum loads for decreased operating costs
- Menu-driven keypad interface for status display, set point control, and system configuration
- CCN compatible
- Primary and secondary status messages
- Individual start/stop schedules for local and CCN operation modes
- Recall of up to 25 alarm/alert messages with diagnostic help
- Two-chiller lead/lag with third chiller standby is standard in the PIC II software
- Optional soft stop unloading closes guide vanes to unload the motor to the configured amperage level prior to stopping
- Languages pre-programmed at factory for English, Chinese, Japanese, Korean (ICVC only)
- An ILT (international language translator) is available for conversion of extended ASCII characters

Safety cutouts

- Bearing oil high temperature*
- Motor high temperature*†
- Refrigerant (condenser) high pressure*†
- Refrigerant (cooler) low temperature*†
- Lube oil low pressure
- Compressor (refrigerant) discharge temperature*
- Under voltage**
- Over voltage**
- Oil pump motor overload
- Motor overload†
- Motor acceleration time
- Intermittent power loss

- Compressor starter faults
- Compressor surge protection*
- Low level ground fault
 - Low voltage — phase to phase and phase to ground
 - Medium voltage — phase to ground
- Cooler freeze protection

Capacity control

- Leaving chilled water control
- Entering chilled water control
- Ice build control
- Soft loading control by temperature or load ramping
- Guide vane actuator module
- Hot gas bypass valve
- Power (demand) limiter
- Auto. chilled water reset
- Variable chiller optimization (VDO) (available on compressor frame sizes 4 and 5 with diffuser control enabled)
- Compressor surge prevention control

Interlocks

- Manual/automatic remote start
- Starting/stopping sequence
 - Pre-lube/post-lube
 - Pre-flow/post-flow
- Compressor starter run interlock
- Pre-start check of safeties and alerts
- Low chilled water (load) recycle
- Monitor/number compressor starts and run hours
- Manual reset of safeties

Indications

- Chiller operating status message
- Power-on
- Pre-start diagnostic check
- Compressor motor amps
- Pre-alarm alert††
- Alarm
- Contact for remote alarm
- Safety shutdown messages
- Elapsed time (hours of operation)
- Chiller input kW

*These can be configured by user to provide alert indication at user-defined limit.

†Override protection: Causes compressor to first unload and then, if necessary, shut down.

**Will not require manual reset or cause an alarm if auto-restart after power failure is enabled.

††By display code only.

CONTROL PANEL DISPLAY (Front View)
ICVC ENGLISH DISPLAY

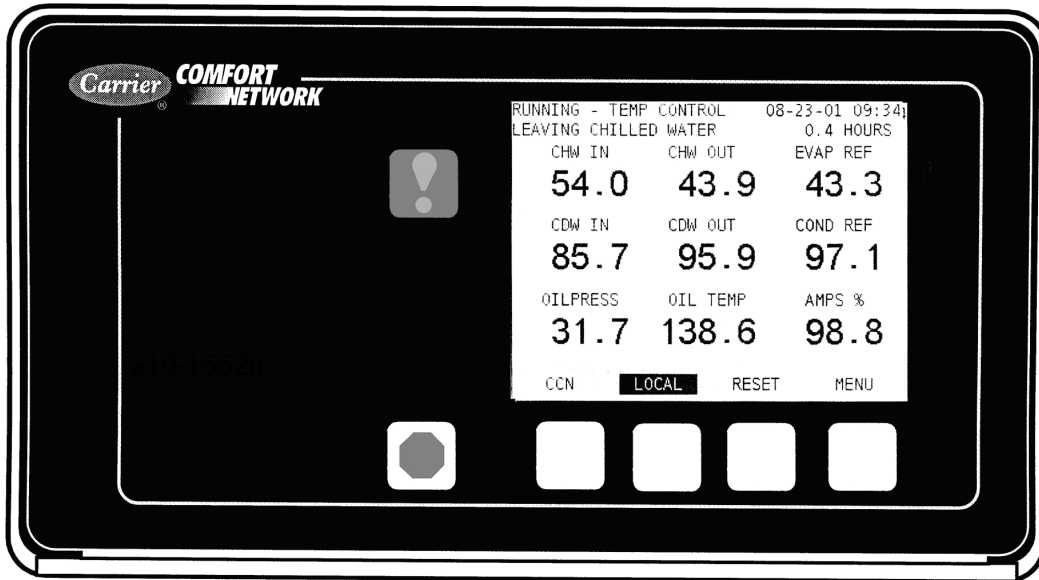

ICVC KOREAN DISPLAY

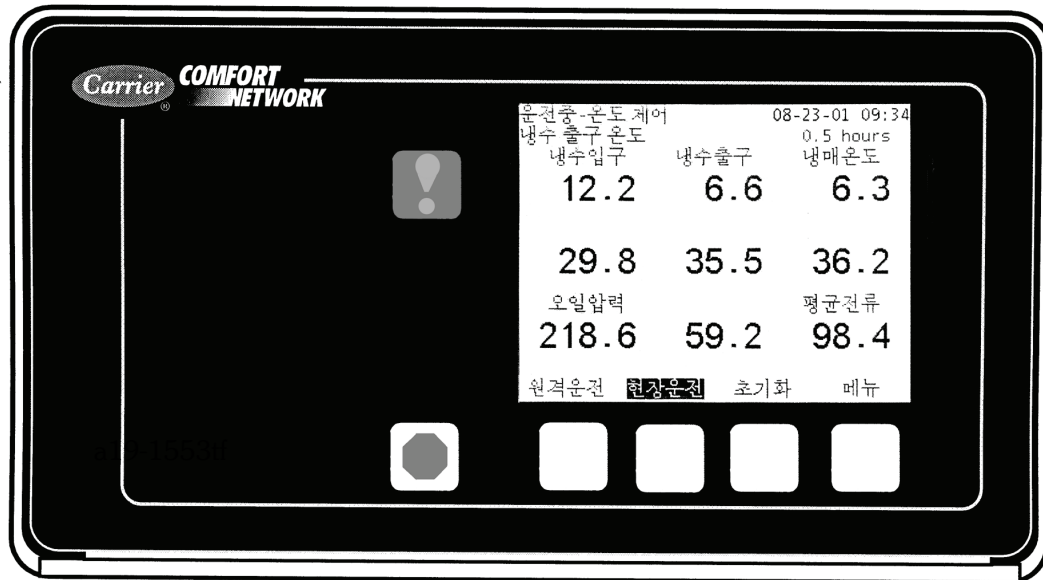

INSIDE PANEL COVER

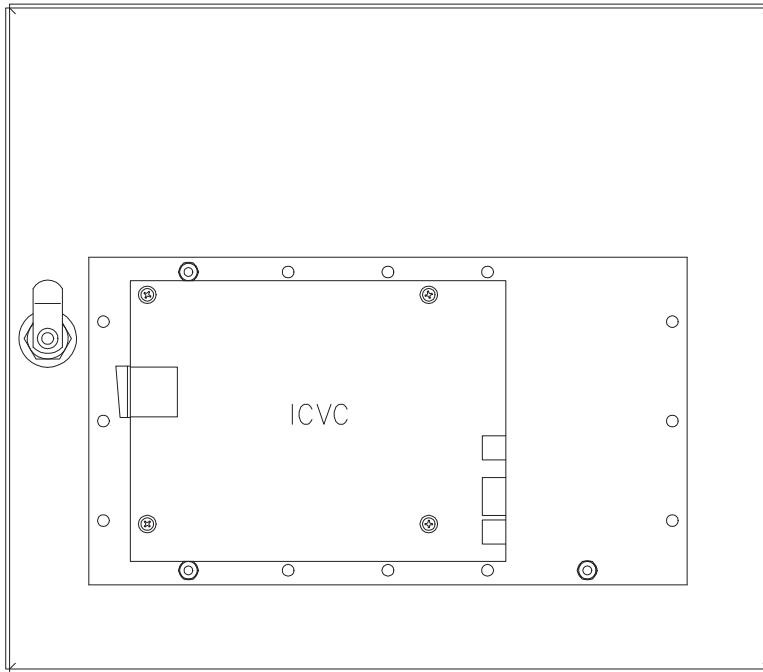

CONTROL PANEL COMPONENT LAYOUT

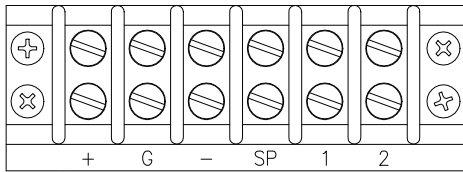

CONTROL PANEL
TERMINAL BLOCK

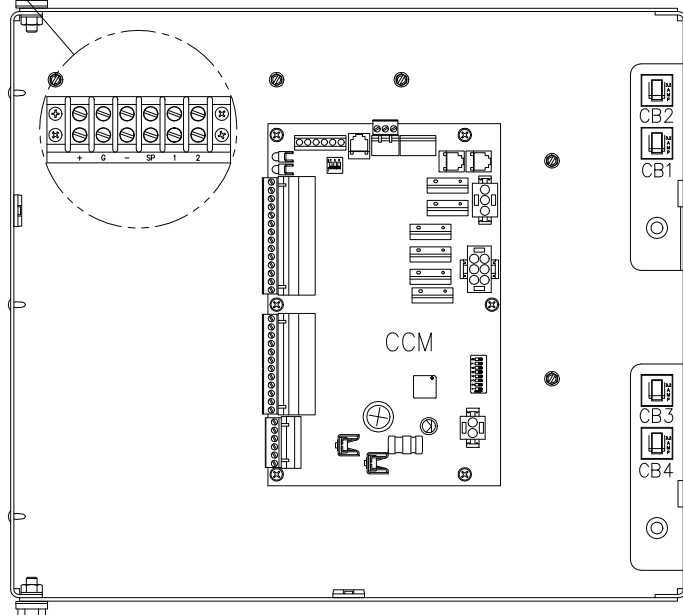

Typical piping and wiring



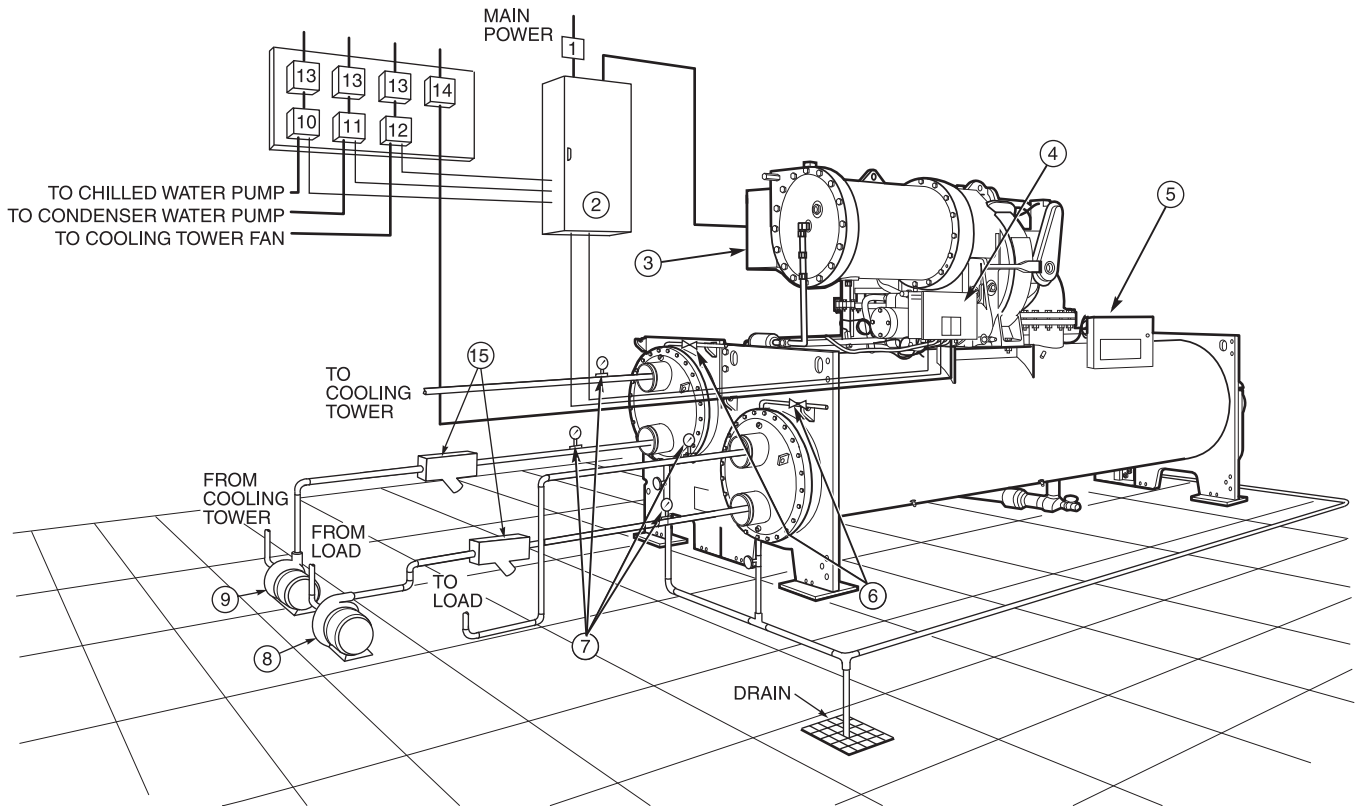

19XR CHILLER WITH FREE-STANDING STARTER OR VFD



LEGEND

- 1 — Disconnect
- 2 — Free-standing Compressor Motor Starter
- 3 — Compressor Motor Terminal Box
- 4 — Power Panel
- 5 — Control Panel
- 6 — Vents
- 7 — Pressure Gages
- 8 — Chilled Water Pump
- 9 — Condenser Water Pump
- 10 — Chilled Water Pump Starter
- 11 — Condensing Water Pump Starter
- 12 — Cooling Tower Fan Starter (Low Fan, High Fan)
- 13 — Disconnect
- 14 — Oil Pump Disconnect (See Note 4)
- 15 — Strainers

-  Piping
-  Control Wiring
-  Power Wiring

NOTES:

1. Wiring and piping shown are for general point-of-connection only and are not intended to show details for a specific installation. Certified field wiring and dimensional diagrams are available on request.
2. All wiring must comply with applicable codes.
3. Wiring not shown for optional devices such as:
 - Remote Start/Stop
 - Remote Alarms
 - Optional Safety Device
 - 4 to 20 mA Resets
 - Optional Remote Sensors
4. Oil pump disconnect may be located within the enclosure of Item 2 — Free-standing Compressor Motor Starter.
5. **IMPORTANT:** Carrier suggests that a structural engineer be consulted if transmission of vibrations from mechanical equipment is of concern.

Typical piping and wiring (cont)



19XR CHILLER WITH OPTIONAL UNIT-MOUNTED STARTER OR VFD

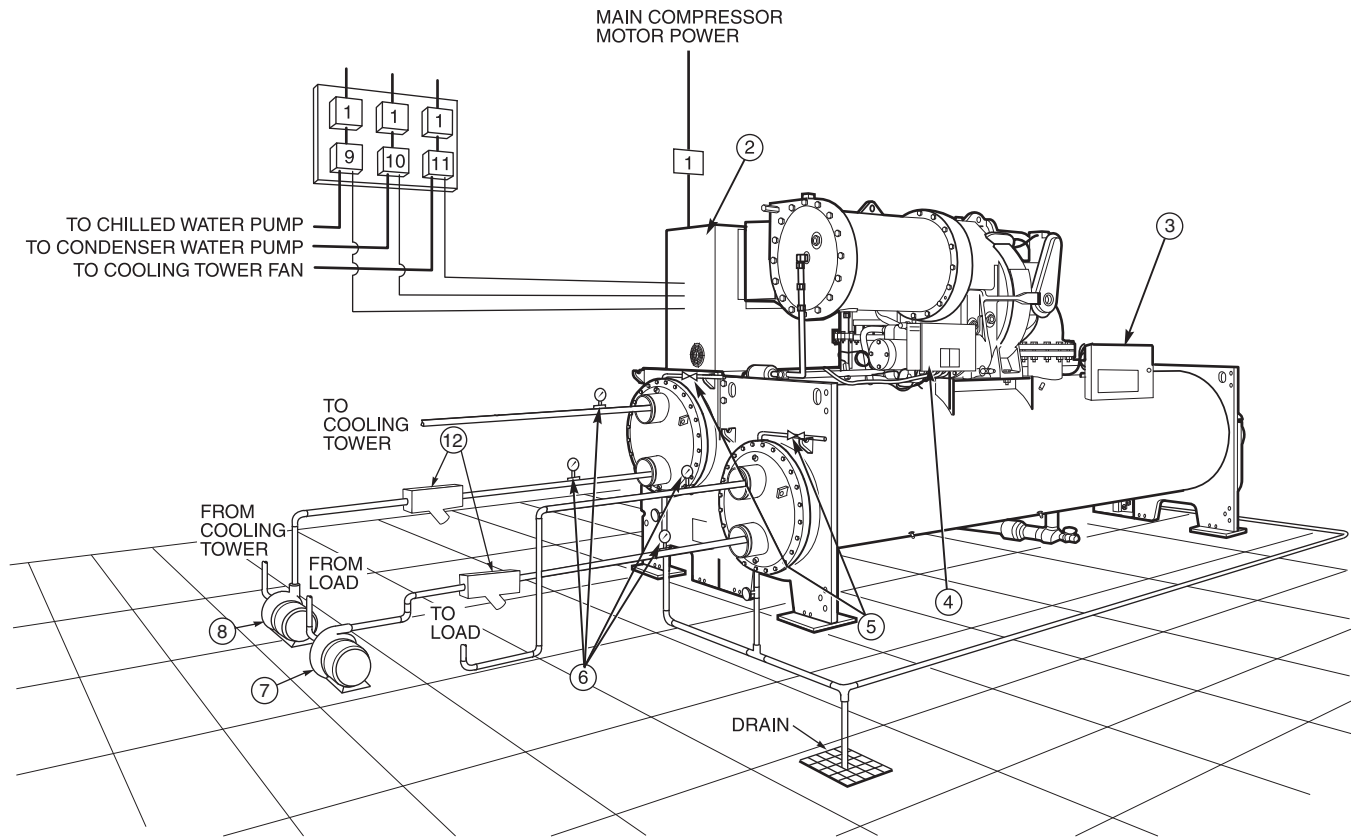

LEGEND

- 1 — Disconnect
 - 2 — Unit-Mounted Starter or VFD
 - 3 — Control Panel
 - 4 — Power Panel
 - 5 — Vents
 - 6 — Pressure Gages
 - 7 — Chilled Water Pump
 - 8 — Condenser Water Pump
 - 9 — Chilled Water Pump Starter
 - 10 — Condensing Water Pump Starter
 - 11 — Cooling Tower Fan Starter (Low Fan, High Fan)
 - 12 — Strainers
- Piping
 Control Wiring
 Power Wiring

NOTES:

1. Wiring and piping shown are for general point-of-connection only and are not intended to show details for a specific installation. Certified field wiring and dimensional diagrams are available on request.
2. All wiring must comply with applicable codes.
3. Wiring not shown for optional devices such as:
 - Remote Start/Stop
 - Remote Alarms
 - Optional Safety Device
 - 4 to 20 mA Resets
 - Optional Remote Sensors
4. **IMPORTANT:** Carrier suggests that a structural engineer be consulted if transmission of vibrations from mechanical equipment is of concern.

19XR,XRV MACHINE FOOTPRINT

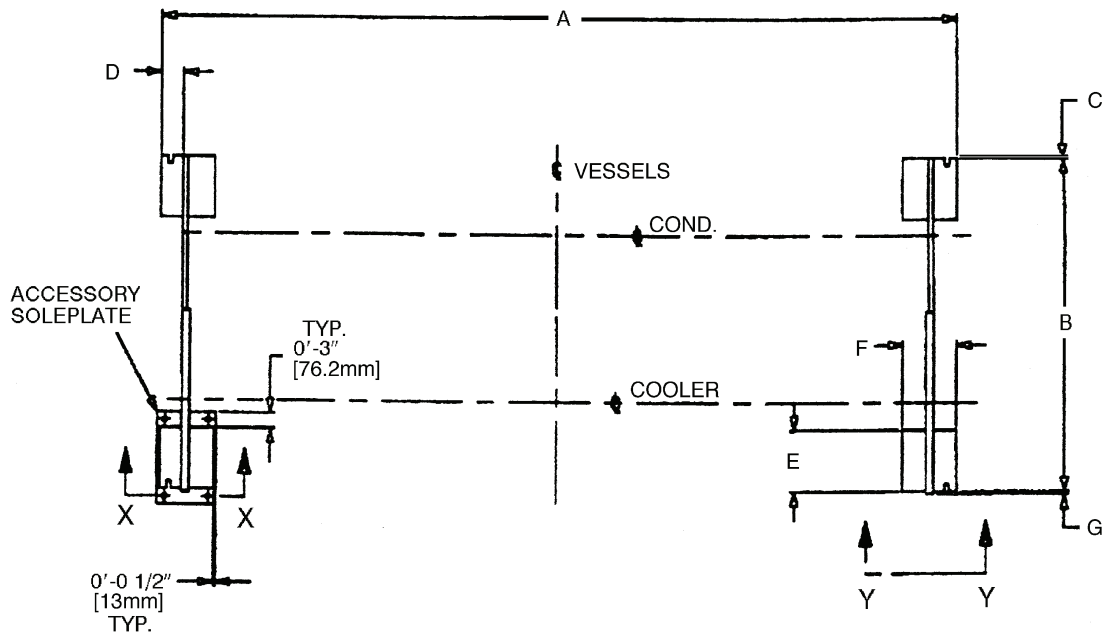

19XR,XRV HEAT EXCHANGER SIZE	DIMENSIONS													
	A		B		C		D		E		F		G	
	ft-in.	mm	ft-in.	mm	ft-in.	mm	ft-in.	mm	ft-in.	mm	ft-in.	mm	ft-in.	mm
10-12	10- 7 ¹ / ₄	3232	4-10 ¹ / ₄	1480	0-1	25	0-3 ⁵ / ₈	92	1-1 ³ / ₄	349	0-9	229	0-1 ¹ / ₂	13
15-17	12-10 ³ / ₄	3931	4-10 ¹ / ₄	1480	0-1	25	0-3 ⁵ / ₈	92	1-1 ³ / ₄	349	0-9	229	0-1 ¹ / ₂	13
20-22	10- 7 ¹ / ₄	3232	5- 4 ¹ / ₄	1632	0-1	25	0-3 ⁵ / ₈	92	1-1 ³ / ₄	349	0-9	229	0-1 ¹ / ₂	13
30-32	12-10 ³ / ₄	3931	5- 4 ¹ / ₄	1632	0	0	0-3 ⁵ / ₈	92	1-1 ³ / ₄	349	0-9	229	0-1 ¹ / ₂	13
35-37	14- 7 ¹ / ₄	4451	5- 4 ¹ / ₄	1632	0	0	0-3 ⁵ / ₈	92	1-1 3/4	349	0-9	229	0-1 ¹ / ₂	13
40-42	12-10 ³ / ₄	3931	6- 0	1829	0-1 ¹ / ₂	38	0-3 ⁵ / ₈	92	1-1 ³ / ₄	349	0-9	229	0-1 ¹ / ₂	13
45-57	14- 7 ¹ / ₄	4451	6- 0	1829	0-1 ¹ / ₂	38	0-3 ⁵ / ₈	92	1-1 ³ / ₄	349	0-9	229	0-1 ¹ / ₂	13
50-54, 5A-5C, 5K-5R	12-10 ³ / ₄	3931	6- 5 ¹ / ₂	1968	0- 1/2	13	0-3 ⁵ / ₈	92	1-1 ³ / ₄	349	0-9	229	0-1 ¹ / ₂	13
55-57, 5F-5H, 5T-5Z	14- 7 ¹ / ₄	4451	6- 5 ¹ / ₂	1968	0- 1/2	13	0-3 ⁵ / ₈	92	1-1 ³ / ₄	349	0-9	229	0-1 ¹ / ₂	13
60-64, 6K-6R	12-10 ³ / ₄	3931	6- 9 ¹ / ₂	2070	0- 1/2	13	0-3 ⁵ / ₈	92	1-1 ³ / ₄	349	0-9	229	0-1 ¹ / ₂	13
65-69, 6T-6Z	14- 7 ¹ / ₄	4451	6- 9 ¹ / ₂	2070	0- 1/2	13	0-3 ⁵ / ₈	92	1-1 ³ / ₄	349	0-9	229	0-1 ¹ / ₂	13
70-74, 7K-7R	15- 1 ⁷ / ₈	4620	7-10 ¹ / ₂	2400	0- 1/4	6	0-6 ¹⁵ / ₁₆	176	1-10	559	1-4	406	0-3/4	19
75-79, 7T-7Z	17- 1 ⁷ / ₈	5229	7-10 ¹ / ₂	2400	0- 1/4	6	0-6 ¹⁵ / ₁₆	176	1-10	559	1-4	406	0-3/4	19
80-84, 8K-8R	15- 1 ⁷ / ₈	4620	8- 9 ³ / ₄	2686	0-15/16	24	0-6 ¹⁵ / ₁₆	176	1-10	559	1-4	406	0-1/16	2
85-89, 8T-8Z	17- 1 ⁷ / ₈	5229	8- 9 ³ / ₄	2686	0-15/16	24	0-6 ¹⁵ / ₁₆	176	1-10	559	1-4	406	0-1/16	2

19XR,XRV ISOLATION WITH ACCESSORY SOLEPLATE PACKAGE

TYPICAL ISOLATION

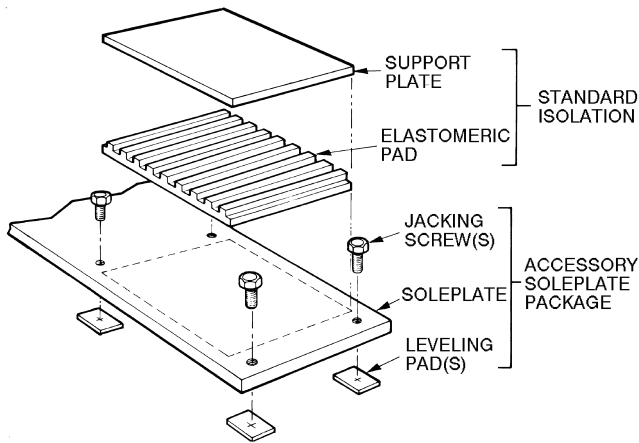

STANDARD ISOLATION

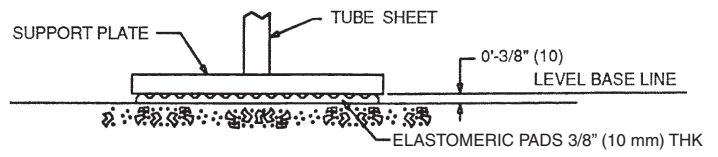

VIEW Y-Y

ISOLATION WITH ISOLATION PACKAGE ONLY (STANDARD)

NOTE: Isolation package includes 4 Elastomeric pads.

ACCESSORY SOLEPLATE DETAIL

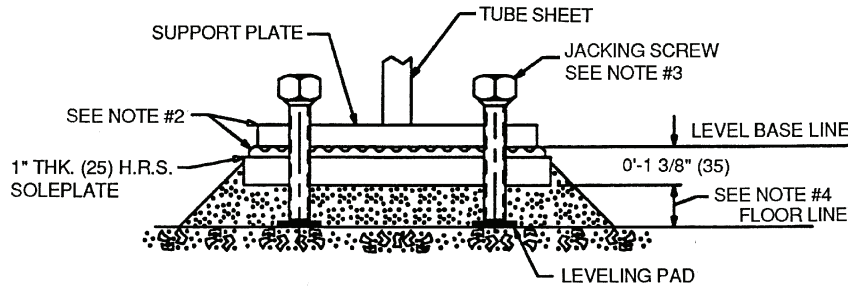

VIEW X-X

NOTES:

1. Dimensions in () are in millimeters.
2. Accessory (Carrier supplied, field installed) soleplate package includes 4 soleplates, 16 jacking screws and leveling pads.
3. Jacking screws to be removed after grout has set.
4. Thickness of grout will vary, depending on the amount necessary to level chiller. Use only pre-mixed non-shrinking grout, Masterflow 648 CP-Plus OR Chemrex Embeco 636 Plus Grout, 0'-1 1/2" (38.1) to 0'-2 1/4" (57) thick.

19XR NOZZLE ARRANGEMENTS
NOZZLE-IN-HEAD WATERBOXES

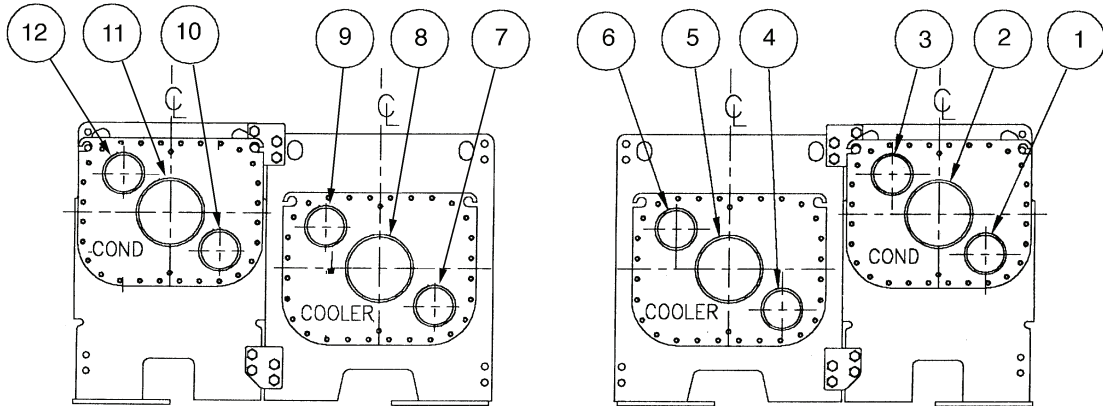

DRIVE END

COMPRESSOR END

FRAMES 1, 2, AND 3

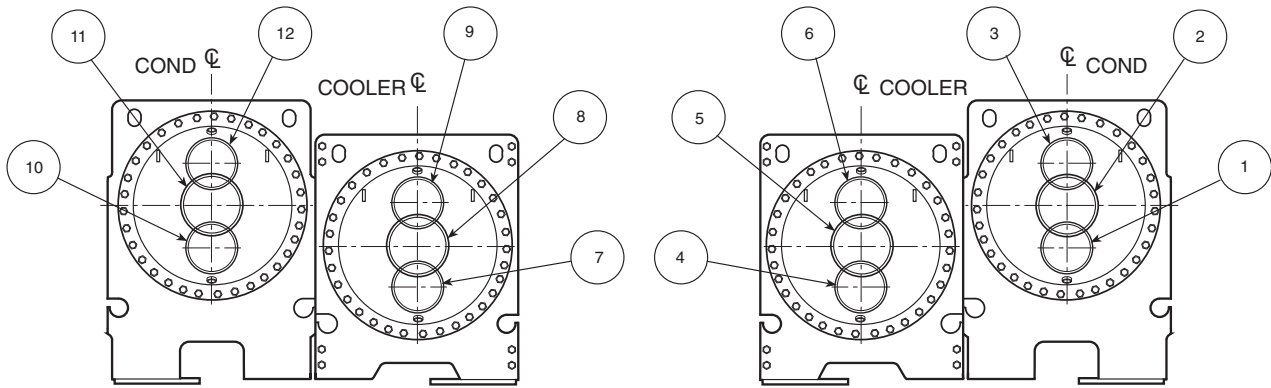

DRIVE END

COMPRESSOR END

FRAMES 4, 5, AND 6

19XR NOZZLE ARRANGEMENTS (cont)

NOZZLE-IN-HEAD WATERBOXES (cont)

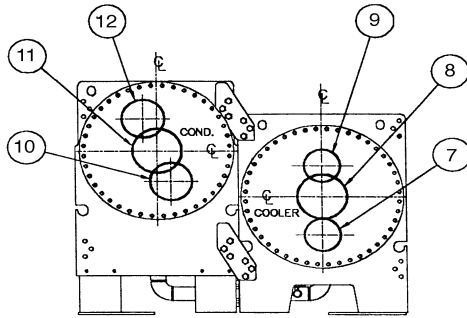

DRIVE END

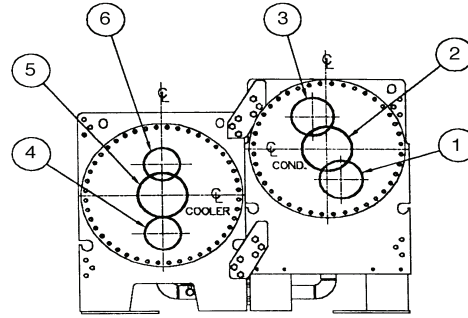

COMPRESSOR END

FRAMES 7 AND 8

NOZZLE ARRANGEMENT CODES FOR ALL 19XR NOZZLE-IN-HEAD WATERBOXES

PASS	COOLER WATERBOXES		
	In	Out	Arrangement Code*
1	8	5	A
	5	8	B
2	7	9	C
	4	6	D
3	7	6	E
	4	9	F

PASS	CONDENSER WATERBOXES		
	In	Out	Arrangement Code*
1	11	2	P
	2	11	Q
2	10	12	R
	1	3	S
3	10	3	T
	1	12	U

*Refer to certified drawings.

MARINE WATERBOXES

NOTE :
COOLER 3-PASS NOZZLE @ 45°
(NOT SHOWN) SIMILIAR TO
CONDENSER 2-PASS

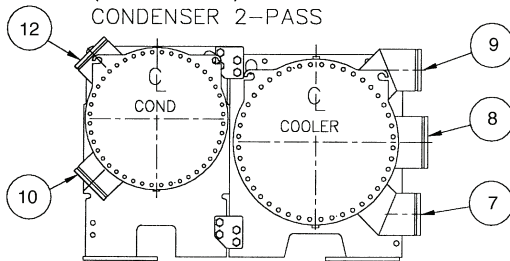

DRIVE END

NOTE :
COOLER 3-PASS NOZZLE @ 45°
(NOT SHOWN) SIMILIAR TO
CONDENSER 2-PASS

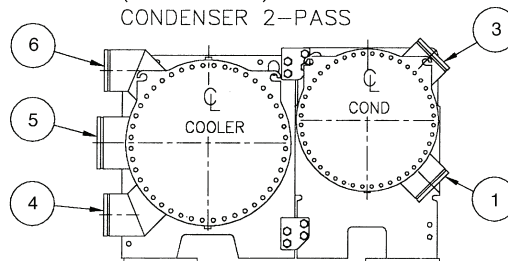

COMPRESSOR END

FRAMES 2 AND 3†

†There is no Frame 1 marine waterbox.

NOZZLE ARRANGEMENT CODES

PASS	COOLER WATERBOXES			CONDENSER WATERBOXES		
	In	Out	Arrangement Code	In	Out	Arrangement Code
1	8	5	A	—	—	—
	5	8	B	—	—	—
2	7	9	C	10	12	R
	4	6	D	1	3	S
3	7	6	E	—	—	—
	4	9	F	—	—	—

19XR NOZZLE ARRANGEMENTS (cont)

MARINE WATERBOXES (cont)

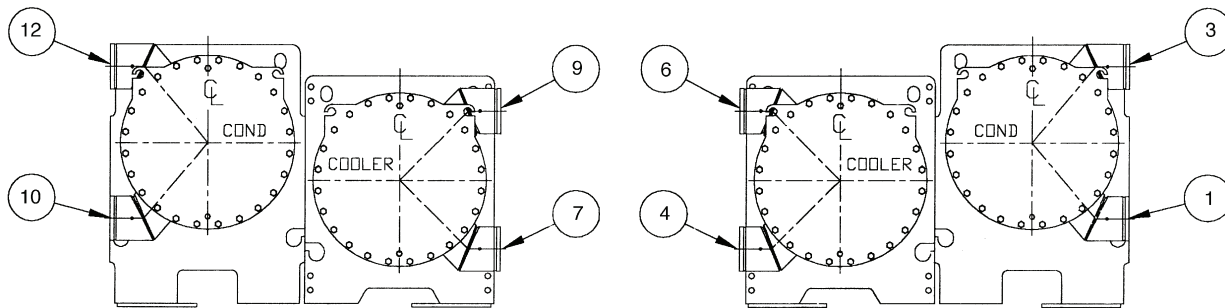

DRIVE END

COMPRESSOR END

FRAMES 4, 5, AND 6

NOZZLE ARRANGEMENT CODES

PASS	COOLER WATERBOXES			CONDENSER WATERBOXES		
	In	Out	Arrangement Code	In	Out	Arrangement Code
1	9	6	A	—	—	—
	6	9	B	—	—	—
2	7	9	C	10	12	R
	4	6	D	1	3	S
3	7	6	E	—	—	—
	4	9	F	—	—	—

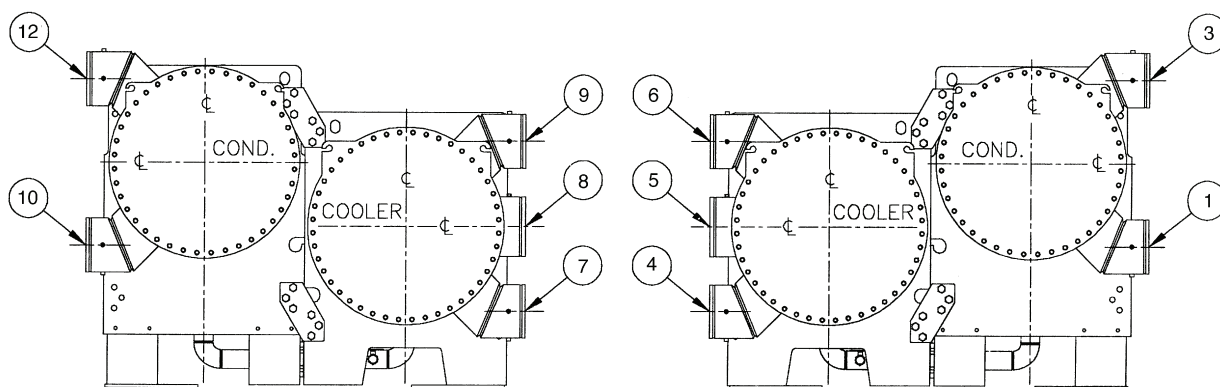

DRIVE END

COMPRESSOR END

FRAMES 7 AND 8

NOZZLE ARRANGEMENT CODES

PASS	COOLER WATERBOXES			CONDENSER WATERBOXES		
	In	Out	Arrangement Code	In	Out	Arrangement Code
1	8	5	A	—	—	—
	5	8	B	—	—	—
2	7	9	C	10	12	R
	4	6	D	1	3	S
3	7	6	E	—	—	—
	4	9	F	—	—	—

Application data (cont)



19XR WATERBOX NOZZLE SIZES (Nozzle-In-Head and Marine Waterboxes)

FRAME SIZE	PRESSURE psig (kPa)	PASS	NOMINAL PIPE SIZE (in.)		ACTUAL PIPE ID (in.)	
			Cooler	Condenser	Cooler	Condenser
1	150/300 (1034/2068)	1	8	8	7.981	7.981
		2	6	6	6.065	6.065
		3	6	6	6.065	6.065
2	150/300 (1034/2068)	1	10	10	10.020	10.020
		2	8	8	7.981	7.981
		3	6	6	6.065	6.065
3	150/300 (1034/2068)	1	10	10	10.020	10.020
		2	8	8	7.981	7.981
		3	6	6	6.065	6.065
4	150/300 (1034/2068)	1	10	10	10.020	10.020
		2	8	8	7.981	7.981
		3	6	6	6.065	6.065
5	150/300 (1034/2068)	1	10	10	10.020	10.020
		2	8	10	7.981	10.020
		3	6	8	6.065	7.981
6	150/300 (1034/2068)	1	10	10	10.020	10.020
		2	10	10	10.020	10.020
		3	8	8	7.981	7.981
7	150 (1034)	1	14	14	13.250	13.250
		2	12	12	12.000	12.000
		3	10	12	10.020	12.000
	300 (2068)	1	14	14	12.500	12.500
		2	12	12	11.376	11.750
		3	10	12	9.750	11.750
8	150 (1034)	1	14	14	13.250	13.250
		2	14	14	13.250	13.250
		3	12	12	12.000	12.000
	300 (2068)	1	14	14	12.500	12.500
		2	14	14	12.500	12.500
		3	12	12	11.376	11.376

RELIEF VALVE LOCATIONS

LOCATION	FRAME SIZE	RELIEF VALVE OUTLET SIZE
COOLER	1-2	1-in. NPT FEMALE CONNECTOR
	3-8	1 1/4-in. NPT FEMALE CONNECTOR
CONDENSER	1-2	1-in. NPT FEMALE CONNECTOR
	3-8	1 1/4-in. NPT FEMALE CONNECTOR
OPTIONAL STORAGE TANK	N/A	1-in. NPT FEMALE CONNECTOR

NOTE: All valves relieve at 185 psig (1275 kPa).

RELIEF VALVE ARRANGEMENT (Refer to 43)

HEAT EXCHANGER FRAME SIZE	COMPRESSOR FRAME SIZE	WITH/WITHOUT DISCHARGE ISOLATION VALVE	COOLER VIEW	CONDENSER VIEW	COOLER NO. VALVES	CONDENSER NO. VALVES
1, 2	2	With Optional Isolation Valve	A	E	1	2
		Without Optional Isolation Valve	C	E	2	2
3	2	With Optional Isolation Valve	A	E	1	2
		Without Optional Isolation Valve	C	E	2	2
3, 4, 5	3	With Optional Isolation Valve	A	E	1	2
		Without Optional Isolation Valve	C	E	2	2
5, 6	4	With Optional Isolation Valve	A	E	1	2
		Without Optional Isolation Valve	C	E	2	2
7, 8	4, 5	With Optional Isolation Valve	B	F	2	4
		Without Optional Isolation Valve	D	F	4	4

RELIEF VALVE ARRANGEMENTS

WITH OPTIONAL ISOLATION OF DISCHARGE AND COOLER

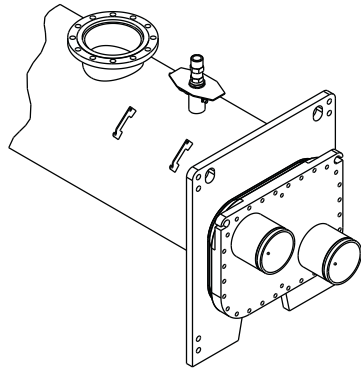

A
FRAME 1-6

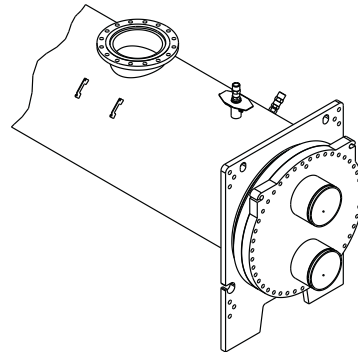

B
FRAME 7, 8

WITHOUT OPTIONAL ISOLATION OF DISCHARGE AND COOLER

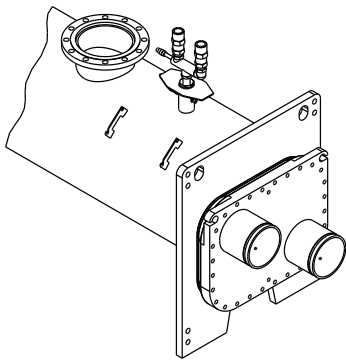

C
FRAME 1-6

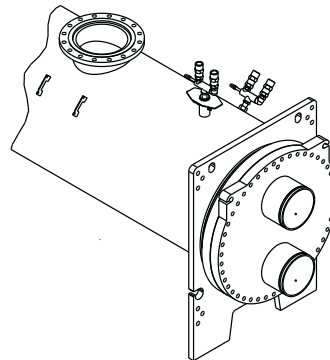

D
FRAME 7, 8

CONDENSER RELIEF VALVE ARRANGEMENT — WITH OR WITHOUT OPTIONAL ISOLATION

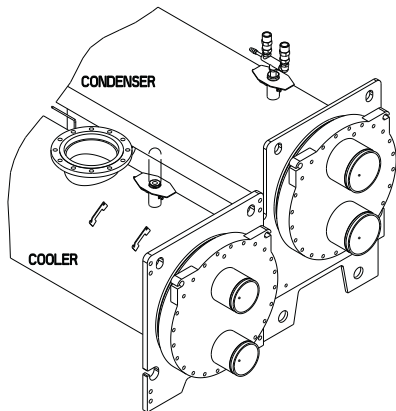

E
FRAME 1-6

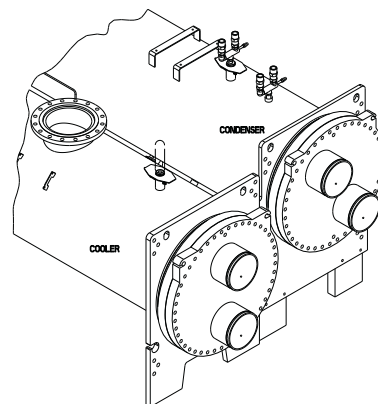

F
FRAME 7, 8

Application data (cont)



Vent and drain connections

Nozzle-in head waterboxes have vent and drain connections on covers. Marine waterboxes have vent and drain connections on waterbox shells.

Provide high points of the chiller piping system with vents and the low points with drains. If shutoff valves are provided in the main water pipes near the unit, a minimal amount of system water is lost when the heat exchangers are drained. This reduces the time required for drainage and saves on the cost of re-treating the system water.

It is recommended that pressure gages be provided at points of entering and leaving water to measure pressure drop through the heat exchanger. Gages may be installed as shown in Pressure Gage Location table. Pressure gages installed at the vent and drain connections do not include nozzle pressure losses.

Use a reliable differential pressure gage to measure pressure differential when determining water flow. Regular gages of the required pressure range do not have the accuracy to provide accurate measurement of flow conditions.

PRESSURE GAGE LOCATION

NUMBER OF PASSES	GAGE LOCATION (Cooler or Condenser)
1 or 3	One gage in each waterbox
2	Two gages in waterbox with nozzles

ASME stamping

All 19XR heat exchangers are constructed in accordance with ASHRAE (American Society of Heating, Refrigerating, and Air Conditioning Engineers) 15 Safety Code for Mechanical Refrigeration (latest edition). This code, in turn, requires conformance with ASME (American Society of Mechanical Engineers) Code for Unfired Pressure Vessels wherever applicable.

Each heat exchanger is ASME 'U' stamped on the refrigerant side of each vessel.

Relief valve discharge pipe sizing

See page 42 for number of relief valves and locations.

Relief-valve discharge piping size should be calculated per ASHRAE 15, latest edition, code using the tabulated C factors for each vessel shown in the table below.

19XR RELIEF VALVE DISCHARGE PIPE SIZING

HEAT EXCHANGER	FRAME SIZE	VESSEL REQUIRED C FACTOR (lb air/Min)	RELIEF VALVE RATED C FACTOR (lb air/Min)	FIELD CONNECTION SIZE (FPT)
COOLER	10 to 12	30.0	37.6	1"
	15 to 17	36.0	37.6	1"
	20 to 22	35.7	37.6	1"
	30 to 32	43.8	70.8	1 1/4"
	35 to 37	49.9	70.8	1 1/4"
	40 to 42	50.4	70.8	1 1/4"
	45 to 47	57.4	70.8	1 1/4"
	50 to 54, 5A-5C, 5K-5R	53.7	70.8	1 1/4"
	55 to 59, 5F-5H, 5T-5Z	61.1	70.8	1 1/4"
	60 to 64, 6K to 6R	57.0	70.8	1 1/4"
	65 to 69, 6T to 6Z	64.9	70.8	1 1/4"
	70 to 74, 7K to 7R	77.0	141.6	1 1/4"
	75 to 79, 7T to 7Z	88.0	141.6	1 1/4"
	80 to 84, 8K to 8R	87.7	141.6	1 1/4"
	85 to 89, 8T to 8Z	100.3	141.6	1 1/4"
CONDENSER	10 to 12	31.7	40.4	1"
	15 to 17	38.0	40.4	1"
	20 to 22	34.0	37.6	1"
	30 to 32	41.8	70.8	1 1/4"
	35 to 37	47.6	70.8	1 1/4"
	40 to 42	47.1	70.8	1 1/4"
	45 to 47	53.7	70.8	1 1/4"
	50 to 54	51.2	70.8	1 1/4"
	55 to 59	58.3	70.8	1 1/4"
	60 to 64	55.3	70.8	1 1/4"
	65 to 69	63.0	70.8	1 1/4"
	70 to 74	72.3	141.6	1 1/4"
	75 to 79	82.7	141.6	1 1/4"
	80 to 84	80.7	141.6	1 1/4"
	85 to 89	92.3	141.6	1 1/4"

Carrier further recommends that an oxygen sensor be installed to protect personnel. Sensor should be able to sense the depletion or displacement of oxygen in the machine room below 19.5% volume oxygen per ASHRAE 15, latest edition.



Design pressures

Design and test pressures for heat exchangers are listed below.

DESIGN AND TEST PRESSURES

19XR

PRESSURES	SHELL SIDE (Refrigerant)		STANDARD TUBE SIDE (Water)		OPTIONAL TUBE SIDE (Water)	
	psig	kPa	psig	kPa	psig	kPa
Leak Test at Design Pressure*	185	1276	150	1034	300	2068
Hydrostatic	—	—	195	1344	390	2690
Proof Test*	204	1407	—	—	—	—

*Nitrogen/Helium.

HEAT EXCHANGER MATERIAL SPECIFICATIONS

ITEM	MATERIAL	SPECIFICATION
Shell	HR Steel	ASME SA516 GR .70
Tube Sheet	HR Steel	ASME SA516 GR .70
Condenser/Cooler Waterbox Cover	HR Steel	ASME SA516 GR .70, SA-36, or SA-285 GRC
Condenser/Cooler Waterbox Shell	HR Steel	ASME SA675 GR .60, SA-516 GR70, or SA-181 CL70
Tubes	Finned Copper	ASME SB359
Discharge/Suction Pipe	Steel	ASME SA106 GRB
Flanges	Steel	ASME SA105

LEGEND

ASME — American Society of Mechanical Engineers
HR — Hot Rolled

Insulation

Factory insulation (optional)

The factory insulation option for the 19XR chiller includes the following areas: cooler (not including waterbox); suction line up to the compressor suction housing; compressor motor and motor cooling return lines; several small oil cooling and oil return system lines, the liquid line, and the float chamber. Optional factory insulation for the 19XRV chiller is available for the evaporator shell and tube sheets, suction elbow, compressor motor, motor refrigerant drain line(s) and VFD refrigerant drain lines (19XRV units only). Insulation applied at the factory is $\frac{3}{4}$ in. (19 mm) thick and has a thermal conductivity K value of 0.28 (Btu in./hr ft^2 °F [(0.0404 • W)/(m • °C)]. Insulation conforms with Underwriters Laboratories (UL) Standard 94, Classification 94HBF.

MINIMUM FIELD-INSTALLED INSULATION REQUIREMENTS

CHILLER	HEAT EXCHANGER SIZE	INSULATION*	
		ft ²	m ²
19XR	10-12	75	6.9
	15-17	85	7.9
	20-22	100	9.3
	30-32	125	11.7
	35-37	135	12.6
	40-42	155	14.4
	45-47	170	15.8
	50-54, 5A-5C, 5K-5R	170	15.8
	55-59, 5F-5H, 5T-5Z	185	17.2
	60-64, 6K-6R	185	17.2
	65-69, 6T-6Z	205	19.1
	70-74, 7K-7R	260	24.2
	75-79, 7T-7Z	295	27.4
	80-84, 8K-8R	310	28.8
	85-89, 8T-8Z	355	32.9

*Factory installed as shown on page 46.

Application data (cont)



Insulation at jobsite — As indicated in the Condensation vs Relative Humidity table, the factory insulation provides excellent protection against condensation under most operating conditions. If temperatures in the equipment area exceed the maximum design conditions, extra insulation is recommended.

If the machine is to be field insulated, obtain the approximate areas from the Minimum Field-Installed Insulation Requirements table.

Insulation of waterbox is made only in the field and this area is not included in Minimum Field-Installed Insulation Requirements table. When insulating the covers, allow for service access and removal of covers. To estimate waterbox cover areas refer to certified drawings.

High humidity jobsite locations may require field supplied and installed insulation on the float chamber, suction housing, and the lower half of the condenser.

CONDENSATION VS RELATIVE HUMIDITY*

AMOUNT OF CONDENSATION	ROOM DRY-BULB TEMP		
	80 F (27 C)	90 F (32 C)	100 F (38 C)
	% Relative Humidity		
None	80	76	70
Slight	87	84	77
Extensive	94	91	84

*These approximate figures are based on 35 F (1.7 C) saturated suction temperature. A 2° F (1.1° C) change in saturated suction temperature changes the relative humidity values by 1% in the same direction.

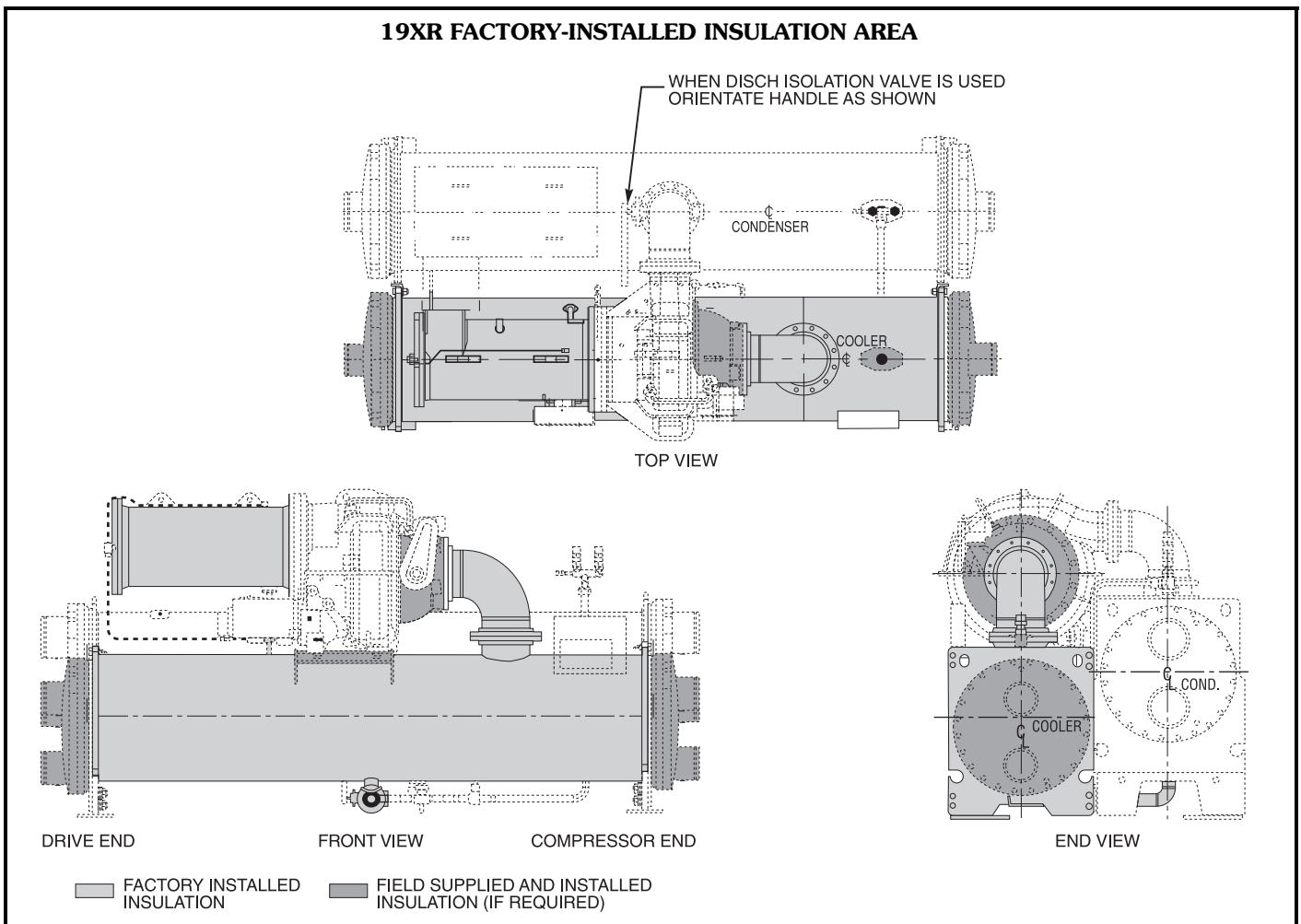

Guide specifications



Packaged Hermetic Centrifugal Liquid Chiller

HVAC Guide Specifications — 19XR, XRV

Size Range:

19XR,XRV — 200 to 1500 Tons (703 to 5275 kW) Nominal

19XRV — 200 to 1500 Tons (703 to 5275 kW) Nominal

Carrier Model Number:

19XR,XRV

Part 1 — General

1.01 SYSTEM DESCRIPTION

- A. Microprocessor-controlled liquid chiller shall use a single stage, semi-hermetic centrifugal compressor using refrigerant HFC-134a.
- B. If a manufacturer proposes a liquid chiller using HCFC-123 refrigerant, then the manufacturer shall include in the chiller price:
 1. A vapor activated alarm system shall be capable of responding to HCFC-123 levels of 10 ppm Allowable Exposure Limit (AEL).
 2. External refrigerant storage tank and pumpout unit.
 3. Zero emission purge unit capable of operating even when the chiller is not operating.
 4. Back-up relief valve to rupture disk.
 5. Chiller pressurizing system to prevent leakage of noncondensables into chiller during shut-down periods.
 6. Plant room ventilation.

1.02 QUALITY ASSURANCE

- A. Chiller performance shall be rated in accordance with AHRI Standard 550/590, latest edition.
- B. Equipment and installation shall be in compliance with ANSI/ASHRAE 15 (latest edition).
- C. Cooler and condenser refrigerant side shall include ASME "U" stamp and nameplate certifying compliance with ASME Section VIII, Division 1 code for unfired pressure vessels.
- D. Chiller shall be designed and constructed to meet UL and UL, Canada requirements and have labels appropriately affixed.
- E. Centrifugal compressor impellers shall be dynamically balanced and over-speed tested by the manufacturer at a minimum of 120% design operating speed. Each compressor assembly shall undergo a mechanical run-in test to verify vibration levels, oil pressures, and temperatures are within acceptable limits.

Each compressor assembly shall be proof tested at a minimum 204 psig (1406 kPa) and leak tested at 185 psig (1276 kPa) with a tracer gas mixture.

- F. Entire chiller assembly shall be proof tested at 204 psig (1406 kPa) and leak tested at 185 psig

(1276 kPa) with a tracer gas mixture on the refrigerant side. The water side of each heat exchanger shall be hydrostatically tested at 1.3 times rated working pressure.

- G. Prior to shipment, the chiller automated controls test shall be executed to check for proper wiring and ensure correct controls operation.
- H. On chillers with unit-mounted compressor motor starter or VFD (variable frequency drive), the chiller and starter/VFD shall be factory wired and tested together to verify proper operation prior to shipment.
 - I. Chiller shall be manufactured at an ISO 9001 facility.

1.03 DELIVERY, STORAGE AND HANDLING

- A. Unit shall be stored and handled in accordance with manufacturer's instructions.
- B. Unit shall be shipped with all refrigerant piping and control wiring factory installed.
- C. Unit shall be shipped charged with oil and full charge of refrigerant HFC-134a or a nitrogen holding charge as specified on the equipment schedule.
- D. Unit shall be shipped with firmly attached labels that indicate name of manufacturer, chiller model number, chiller serial number, and refrigerant used.
- E. If the chiller is to be exported, the unit shall be sufficiently protected from the factory against sea water corrosion to be suitable for shipment in a standard open top, ocean shipping container (19XR, 19XRV heat exchanger frames 1 through 6 only).

1.04 WARRANTY

Warranty shall include parts and labor for one year after start-up or 18 months from shipment, whichever occurs first. A refrigerant warranty shall be provided for a period of five years.

Part 2 — Products

2.01 EQUIPMENT

A. General:

Factory assembled, single piece, liquid chiller shall consist of compressor, motor, starter or variable frequency drive, lubrication system, cooler, condenser, initial oil and refrigerant operating charges, microprocessor control system, and documentation required prior to start-up. An optional compressor motor starter or VFD can be mounted on the chiller, wired, and tested by the chiller manufacturer.

B. Compressor:

1. One centrifugal compressor of the high performance, single-stage type.
2. Compressor, motor, and transmission shall be hermetically sealed into a common assembly and arranged for easy field servicing.
3. Internal compressor parts must be accessible for servicing without removing the compressor base from the chiller. Connections to the compressor casing shall use O-rings instead of

Guide specifications (cont)



gaskets to reduce the occurrence of refrigerant leakage. Connections to the compressor shall be flanged or bolted for easy disassembly.

4. All pressure transducers shall have quick disconnects to allow replacement of the sensor without replacement of the entire sensor wire. Pressure transducers shall be capable of field calibration to ensure accurate readings and to avoid unnecessary transducer replacement. Pressure transducers and temperature sensors shall be serviceable without the need for refrigerant charge removal or isolation.
5. Transmission shall be single ratio, single helical, parallel shaft speed increaser. Gears shall conform to AGMA Standards, Quality II.
6. Journal bearings shall be of the steel backed babbitt lined type. Aluminum journal bearings are not acceptable. The thrust bearing shall be tilting pad or rolling element type.
7. Centrifugal compressors shall use variable inlet guide vanes to provide capacity modulation while also providing pre-whirl of the refrigerant vapor entering the impeller for more efficient compression at all loads.
8. Centrifugal compressors shall be provided with a factory-installed lubrication system to deliver oil under pressure to bearings and transmission. Included in the system shall be:
 - a. Hermetic driven rotary vane oil pump with factory-installed motor contactor with overload protection.
 - b. Refrigerant-cooled oil cooler. Water-cooled oil coolers are not acceptable.
 - c. Oil pressure regulator.
 - d. Oil filter with isolation valves to allow filter change without removal of refrigerant charge.
 - e. Oil sump heater controlled from unit microprocessor.
 - f. Oil reservoir temperature sensor with main control center digital readout.
 - g. When factory-mounted compressor motor starter or VFD is provided, all wiring to oil pump, oil heater, and controls shall be pre-wired in the factory.
 - h. Compressor shall be fully field serviceable. Compressors which must be removed and returned to the factory for service shall be unacceptable.

C. Motor:

1. Compressor motor shall be of the semi-hermetic, liquid refrigerant cooled, squirrel cage, induction type suitable for voltage shown on the equipment schedule.
2. If an open drive motor is provided, a compressor shaft seal leakage containment system shall be provided.

- a. An oil reservoir shall collect oil and refrigerant that leaks past the seal.
 - b. A float device shall be provided to open when the reservoir is full, directing the refrigerant/oil mixture back into the compressor housing.
 - c. A refrigerant sensor shall be located next to the open drive seal to detect leaks.
3. Motors shall be suitable for operation in a refrigerant atmosphere and shall be cooled by atomized refrigerant in contact with the motor windings.
 4. Motor stator shall be arranged for service or removal with only minor compressor disassembly and without removing main refrigerant piping connections.
 5. Full load operation of the motor shall not exceed nameplate rating.
 6. One motor winding temperature sensor (and one spare) shall be provided.
 7. Should the mechanical contractor choose to provide a chiller with an open motor instead of the specified semi-hermetic motor, the contractor shall install additional cooling equipment to dissipate the motor heat as per the following formula:

$$\text{Btuh} = (\text{FLkW motor}) (0.05) (3413)$$

$$\text{Btuh} = (\text{FLkW motor}) (171)$$

and, alternately

$$\text{Tons} = \text{Btuh} / 12,000$$

The additional piping, valves, air-handling equipment, insulation, wiring, switchgear changes, ductwork, and coordination with other trades shall be the responsibility of the mechanical contractor. Shop drawings reflecting any changes to the design shall be included in the submittal, and incorporated into the final as-built drawings for the project.

8. Also, if an open motor is provided, a mechanical room thermostat shall be provided and set at 104 F (40 C). If this temperature is exceeded, the chillers shall shut down and an alarm signal shall be generated to the central Energy Management System (EMS) display module prompting the service personnel to diagnose and repair the cause of the over temperature condition. The mechanical contractor shall be responsible for all changes to the design, including coordination with temperature control, electrical and other trades. In addition, the electrical power consumption of any auxiliary ventilation and/or mechanical cooling required to maintain the mechanical room conditions stated above shall be considered in the determination of conformance to the scheduled chiller energy efficiency requirement.

D. Cooler and Condenser:

1. Cooler shall be of shell and tube type construction, each in separate shells. Units shall be fabricated with high-performance tubing, minimum ¼ in. (6 mm) steel shell and tube sheets with fabricated steel waterboxes.
 - a. Waterbox shall be nozzle-in-head waterbox (150 psig [1034 kPa]).
 - b. Waterbox shall have standard Victaulic grooves.
2. Condenser shall be of shell and tube type construction, each in separate shells. Units shall be fabricated with high-performance tubing, minimum ¼ in. (6 mm) steel shell and tube sheets with fabricated steel waterboxes.
 - a. Waterbox shall be nozzle-in-head (150 psig [1034 kPa]).
 - b. Waterbox shall have standard Victaulic grooves.
3. Waterboxes shall have vents, drains, and covers to permit tube cleaning within the space shown on the drawings. A thermistor type temperature sensor with quick connects shall be factory installed in each water nozzle.
4. Tubes shall be individually replaceable from either end of the heat exchanger without affecting the strength and durability of the tube sheet and without causing leakage in adjacent tubes.
5. Tubing shall be copper, high-efficiency type, with integral internal and external enhancement unless otherwise noted. Tubes shall be nominal ¾-in. or 1 in. OD with nominal wall thickness of 0.025 in. measured at the root of the fin at the enhanced areas and nominal wall thickness of 0.049 in. where the tubes are in contact with the end tube sheets unless otherwise noted. Tubes shall be rolled into tube sheets and shall be individually replaceable. Tube sheet holes shall be double grooved for joint structural integrity.
6. Cooler shall be designed to prevent liquid refrigerant from entering the compressor. Devices that introduce pressure losses (such as mist eliminators) shall not be acceptable because they are subject to structural failures that can result in extensive compressor damage.
7. The condenser shell shall include a FLASC (flash subcooler) which cools the condensed liquid refrigerant to a reduced temperature, thereby increasing the refrigeration cycle efficiency.
8. A reseating type pressure relief valve shall be installed on each heat exchanger. If a non-reseating type is used, a backup reseating type shall be installed in series.

E. Refrigerant Flow Control:

To improve part load efficiency, liquid refrigerant shall be metered from the condenser to the cooler

using a float-type metering valve to maintain the proper liquid level of refrigerant in the heat exchangers under both full and part load operating conditions.

By maintaining a liquid seal at the flow valve, bypassed hot gas from the condenser to the cooler is eliminated. The float valve chamber shall have a bolted access cover to allow field inspection and the float valve shall be field serviceable.

F. Controls, Safeties, and Diagnostics:

1. Controls:

- a. The chiller shall be provided with a factory installed and wired microprocessor control center. The control center shall include a 16-line by 40-character liquid crystal display, 4 function keys, stop button, and alarm light. The microprocessor can be configured for either English or SI units.
- b. All chiller and starter monitoring shall be displayed at the chiller control panel.
- c. The controls shall make use of non-volatile memory.
- d. The chiller control system shall have the ability to interface and communicate directly to the building control system.
- e. The default standard display screen shall simultaneously indicate the following minimum information:
 - 1) date and time of day
 - 2) 24-character primary system status message
 - 3) 24-character secondary status message
 - 4) chiller operating hours
 - 5) entering chilled water temperature
 - 6) leaving chilled water temperature
 - 7) evaporator refrigerant temperature
 - 8) entering condenser water temperature
 - 9) leaving condenser water temperature
 - 10) condenser refrigerant temperature
 - 11) oil supply pressure
 - 12) oil sump temperature
 - 13) percent motor rated load amps (RLA)
- f. In addition to the default screen, status screens shall be accessible to view the status of every point monitored by the control center including:
 - 1) evaporator pressure
 - 2) condenser pressure
 - 3) bearing oil supply temperature
 - 4) compressor discharge temperature
 - 5) motor winding temperature
 - 6) number of compressor starts
 - 7) control point settings
 - 8) discrete output status of various devices
 - 9) compressor motor starter status
 - 10) optional spare input channels
 - 11) current and voltage for each phase
 - 12) frequency

Guide specifications (cont)



g. Schedule Function:

The chiller controls shall be configurable for manual or automatic start-up and shutdown. In automatic operation mode, the controls shall be capable of automatically starting and stopping the chiller according to a stored user programmable occupancy schedule. The controls shall include built-in provisions for accepting:

- 1) A minimum of two 365-day occupancy schedules.
- 2) Minimum of 8 separate occupied/unoccupied periods per day.
- 3) Daylight savings start/end.
- 4) 18 user-defined holidays.
- 5) Means of configuring an occupancy timed override.
- 6) Chiller start-up and shutdown via remote contact closure.

h. Service Function:

The controls shall provide a password protected service function which allows authorized individuals to view an alarm history file which shall contain the last 25 alarm/alert messages with time and date stamp. These messages shall be displayed in text form, not codes.

i. Network Window Function:

Each chiller control panel shall be capable of viewing multiple point values and statuses from other like controls connected on a common network, including controller maintenance data. The operator shall be able to alter the remote controller's set points or time schedule and to force point values or statuses for those points that are operator forcible. The control panel shall also have access to the alarm history file of all like controllers connected on the network.

j. Pump Control:

Upon request to start the compressor, the control system shall start the chilled water pump, condenser water pumps and verify that flows have been established.

k. Ramp Loading:

A user-configurable ramp loading rate, effective during the chilled water temperature pulldown period, shall control the rate of guide vane opening to prevent a rapid increase in compressor power consumption. The controls shall allow configuration of the ramp loading rate in either degrees/minute of chilled water temperature pulldown or percent motor amps/minute. During the ramp loading period, a message shall be displayed informing the operator that the chiller is operating in ramp loading mode.

l. Chilled Water Reset:

The control center shall allow reset of the chilled water temperature set point based on any one of the following criteria:

- 1) Chilled water reset based on an external 4 to 20 mA signal.
- 2) Chilled water reset based on a remote temperature sensor (such as outdoor air).
- 3) Chilled water reset based on water temperature rise across the evaporator.

m. Demand Limit:

The control center shall limit amp draw of the compressor to the rated load amps or to a lower value based on one of the following criteria:

- 1) Demand limit based on a user input ranging from 40% to 100% of compressor rated load amps.
- 2) Demand limit based on external 4 to 20 mA signal.

n. Controlled Compressor Shutdown:

The controls shall be capable of being configured to soft stop the compressor. When the stop button is pressed or remote contacts open with this feature active, the guide vanes shall close to a configured amperage level and the machine shall then shut down. The display shall indicate "shutdown in progress."

2. Safeties:

a. Unit shall automatically shut down when any of the following conditions occur: (Each of these protective limits shall require manual reset and cause an alarm message to be displayed on the control panel screen, informing the operator of the shutdown cause.)

- 1) motor overcurrent
- 2) over voltage*
- 3) under voltage*
- 4) single cycle dropout*
- 5) bearing oil high temperature
- 6) low evaporator refrigerant temperature
- 7) high condenser pressure
- 8) high motor temperature
- 9) high compressor discharge temperature
- 10) low oil pressure
- 11) prolonged surge
- 12) loss of cooler water flow
- 13) loss of condenser water flow
- 14) starter fault

*Shall not require manual reset or cause an alarm if auto-restart after power failure is enabled.

b. The control system shall detect conditions that approach protective limits and take self-corrective action prior to an alarm occurring. The system shall automatically reduce

chiller capacity when any of the following parameters are outside their normal operating range:

- 1) high condenser pressure
- 2) high motor temperature
- 3) low evaporator refrigerant temperature
- 4) surge prevention control
- 5) high motor amps.

c. During the capacity override period, a pre-alarm (alert) message shall be displayed informing the operator which condition is causing the capacity override. Once the condition is again within acceptable limits, the override condition shall be terminated and the chiller shall revert to normal chilled water control. If during either condition the protective limit is reached, the chiller shall shut down and a message shall be displayed informing the operator which condition caused the shutdown and alarm.

d. Internal built-in safeties shall protect the chiller from loss of water flow. Differential pressure switches shall not be allowed to be the only form of freeze protection.

3. Diagnostics and Service:

A self diagnostic controls test shall be an integral part of the control system to allow quick identification of malfunctioning components.

Once the controls test has been initiated, all pressure and temperature sensors shall be checked to ensure they are within normal operating range. A pump test shall automatically energize the chilled water pump, condenser water pump, and oil pump. The control system shall confirm that water flow and oil pressure have been established and require operator confirmation before proceeding to the next test. A guide vane actuator test shall open and close the guide vanes to check for proper operation. The operator manually acknowledges proper guide vane operation prior to proceeding to the next test.

In addition to the automated controls test, the controls shall provide a manual test which permits selection and testing of individual control components and inputs. A thermistor test and transducer test shall display on the ICVC (International Chiller Visual Controller) screen the actual reading of each transducer and each thermistor installed on the chiller. All out-of-range sensors shall be identified.

4. Multiple Chiller Control:

The chiller controls shall be supplied as standard with a two-chiller lead/lag and a third chiller standby system. The control system shall automatically start and stop a lag or second chiller on a two-chiller system. If one of the two chillers on line goes into a fault mode, the third standby chiller shall be automatically started.

The two-chiller lead/lag system shall allow manual rotation of the lead chiller, include load balancing if configured, and a staggered restart of the chillers after a power failure.

G. Electrical Requirements:

1. Electrical contractor shall supply and install main electrical power line, disconnect switches, circuit breakers, and electrical protection devices per local code requirements and as indicated necessary by the chiller manufacturer.
2. Electrical contractor shall wire the chilled water pump, condenser water pump, and tower fan control circuit to the chiller control circuit.
3. Electrical contractor shall supply and install electrical wiring and devices required to interface the chiller controls with the building control system if applicable.
4. Electrical power shall be supplied to the unit at the voltage, phase, and frequency listed in the equipment schedule.

H. Piping Requirements — Instrumentation and Safeties:

Mechanical contractor shall supply and install pressure gages in readily accessible locations in piping adjacent to the chiller such that they can be easily read from a standing position on the floor. Scale range shall be such that design values shall be indicated at approximately mid-scale.

Gages shall be installed in the entering and leaving water lines of the cooler and condenser.

I. Vibration Isolation:

Chiller manufacturer shall furnish neoprene isolator pads for mounting equipment on a level concrete surface.

J. Start-up:

1. The chiller manufacturer shall provide a factory-trained representative, employed by the chiller manufacturer, to perform the start-up procedures as outlined in the Start-up, Operation and Maintenance manual provided by the chiller manufacturer.
2. Manufacturer shall supply the following literature:
 - a. Start-up, operation and maintenance instructions.
 - b. Installation instructions.
 - c. Field wiring diagrams.
 - d. One complete set of certified drawings.

K. Special Features:

1. Soleplate Package Accessory:

Unit manufacturer shall furnish a soleplate package consisting of soleplates, jacking screws, leveling pads, and neoprene pads.

2. Spring Isolators Accessory:

Field furnished and selected for the desired degree of isolation.

Guide specifications (cont)



3. Spare Sensors with Leads Accessory:
Unit manufacturer shall furnish additional temperature sensors and leads.
4. Sound Insulation Kit Accessory:
Unit manufacturer shall furnish a sound insulation kit that covers (select):
 - a. The compressor discharge pipe.
 - b. The compressor housing and motor housing.
 - c. The condenser shell and suction line.Blanket construction shall allow for installation and removal without the use of tape or caulk. Insulation material shall be 11 lb/cu ft fiberglass. Insulation design shall accommodate temperature and pressure probes, gages, tubing, piping, and brackets. An extended 2-in. wide vinyl flap shall cover all exposed seams, thereby minimizing any potential noise leaks. An aluminum nameplate shall be riveted to each blanket piece. Each tag shall be embossed or etched with lettering indicating piece location, description, size, and tag number sequence.
5. Stand-Alone Pumpout Unit Accessory:
A free-standing pumpout shall be provided. The pumpout unit shall use a hermetic reciprocating compressor with water-cooled condenser. Condenser water piping, 3-phase motor power shall be installed at the jobsite by the installing contractor.
6. Separate Storage Tank and Pumpout Unit Accessory:
A free-standing refrigerant storage tank and pumpout unit shall be provided. The storage vessels shall be designed per ASME Section VIII Division 1 code with 185 psig (1276 kPa) design pressure. Double relief valves per ANSI/ASHRAE 15, latest edition, shall be provided. The tank shall include a liquid level gage and pressure gage. The pumpout unit shall use a hermetic reciprocating compressor with water-cooled condenser. Condenser water piping and 3-phase motor power shall be installed at the jobsite by the installing contractor.
7. Building Control System Interface (LON) Accessory:
The chiller control system shall have the ability to interface and communicate directly to the building control using a LON-based system. The LonWorks Carrier Translator shall output data in standard LON profiles.
8. Refrigerant Charge:
The chiller shall ship from the factory fully charged with R-134a refrigerant and oil.
9. Thermal Insulation:
Unit manufacturer shall insulate the cooler shell, economizer low side compressor suction elbow, motor shell and motor cooling lines.

- Insulation shall be $\frac{3}{4}$ in. (19 mm) thick with a thermal conductivity not exceeding 0.28 (Btu in.)/hr ft² F and shall conform to UL standard 94, classification 94 HBF.
10. Automatic Hot Gas Bypass:
Hot gas bypass valve and piping shall be factory furnished to permit chiller operation for extended periods of time.
11. Cooler and Condenser Tubes:
Contact local Carrier representative for other tube offerings.
12. Cooler and Condenser Passes:
Unit manufacturer shall provide the cooler and/or condenser with 1, 2 or 3 pass configuration on the water side.
13. Nozzle-In-Head, 300 psig (2068 kPa):
Unit manufacturer shall furnish nozzle-in-head style waterboxes on the cooler and/or condenser rated at 300 psig (2068 kPa).
14. Marine Waterboxes, 150 psig (1034 kPa):
Unit manufacturer shall furnish marine style waterboxes on cooler and/or condenser rated at 150 psig (1034 kPa).
15. Marine Waterboxes, 300 psig (2068 kPa):
Unit manufacturer shall furnish marine style waterboxes on cooler and/or condenser rated at 300 psig (2068 kPa).
16. Flanged Water Nozzles:
Unit manufacturer shall furnish standard flanged piping connections on the cooler and/or condenser.
17. Hinges:
Unit manufacturer shall furnish hinges on waterboxes to facilitate tube cleaning.
18. Pumpout Unit:
A refrigerant pumpout system shall be installed on the chiller. The pumpout system shall include a hermetic compressor and drive, piping, wiring, and motor.
19. Optional Compressor Discharge Isolation Valve and Liquid Line Ball Valve:
These items shall be factory installed to allow isolation of the refrigerant charge in the condenser for servicing the compressor.
20. Optional Seismic Isolation Package:
Package shall meet International Building Code and ASCE 7 seismic qualification requirements in concurrence with ICC ES AC156 Acceptance Criteria for Seismic Qualification by Shake-Table Testing of Nonstructural Components and Systems. Manufacturer shall provide seismic certificate from OSHPD (California only).



21. BACnet Communication Option:
Shall provide factory-installed communication capability with a BACnet MS/TP network. Allows integration with i-Vu[®] Open control system or a BACnet building automation system.
22. Optional Low-Voltage Unit-Mounted Starter (not available on chiller heat exchanger size 8):
An optional reduced voltage wye-delta or solid-state starter shall be supplied. The compressor motor starter shall be factory mounted, wired and tested prior to shipment by the chiller manufacturer. Customer electrical connection for compressor motor power shall be limited to main power leads to the starter, and wiring water pumps and tower fans to the chiller control circuit.
 - a. NEMA 1 enclosure with integral fan cooling and lockable hinged doors.
 - b. Main power disconnect (non-fused type).
 - c. Capability to start and stop chiller, pumps and tower fans.
 - d. 3 kva control/oil heater transformer.
 - e. Branch circuit breaker to provide power for oil pump.
 - f. Branch circuit breaker to provide power for control power and oil heater.
 - g. The following standard features:
 - 1) Phase loss
 - 2) Phase reversal
 - 3) Phase imbalance
 - 4) 3-phase ground fault
 - 5) Low voltage — phase to phase and phase to ground
 - 6) Medium voltage — phase to ground
 - 7) Current overload
 - 8) Current flow while stopped
 - 9) 3-phase under/over voltage
 - 10) 3-phase digital ammeter/voltmeter
 - 11) Microprocessor based overload trip protection
 - 12) Frequency
 - h. Optional solid-state starter (not available on chiller heat exchanger size 8) shall provide stepless compressor motor acceleration. The starter shall include 6 silicon controlled rectifiers (SCRs) with integrally mounted bypass once the motor has achieved full voltage and speed. The starter shall also display the following:
 - 1) Starter On
 - 2) Run (up to voltage)
 - 3) Phase Correct
 - 4) Over Temperature Fault
 - 5) SCR Gates Energized
 - 6) Ground Fault
 - 7) Current Imbalance Fault
 - 8) Shorted SCR
23. Unit-Mounted Variable Frequency Drive (VFD) with Built-in Harmonic Filter (Liqui-Flo™2):
 - a. Design:
 - 1) VFD shall be refrigerant cooled, micro-processor based, pulse width modulated (PWM) design. Water-cooled designs are not acceptable.
 - 2) Input and output power devices shall be insulated gate bipolar transistors (IGBTs).
 - 3) Active rectifier shall convert incoming voltage / frequency to DC voltage. Input current and voltage shall be regulated.
 - 4) Transistorized inverter and control regulator shall convert DC voltage to a sinusoidal PWM waveform.
 - 5) Integrated chiller controls shall coordinate motor speed and guide vane position to optimize chiller performance over all chiller operating conditions.
 - 6) Surge prevention and surge protection algorithms shall take action to prevent surge and move chiller operation away from surge.
 - b. Enclosure:
 - 1) Pre-painted unit mounted, NEMA 1 cabinet shall include hinged, lockable doors and removable lifting lugs.
 - 2) VFD shall have a short circuit interrupt and withstand rating of at least 65,000 amps (35,000 amps for 575-v units).
 - 3) Provisions to padlock main disconnect handle in the “Off” positions shall be provided. Mechanical interlock to prevent opening cabinet door with disconnect in the “On” position or moving disconnect to the “ON” position while the door is open shall be provided.
 - 4) Provisions shall be made for top entry of incoming line power cables.
 - c. Heat Sink:
 - 1) The heat sink shall be refrigerant cooled. Heat sink and mating flange shall be suitable for ASME design working pressure of 185 psig (1276 kPa).
 - 2) Refrigerant cooling shall be metered by microprocessor control solenoid valve to maintain heat sink temperature within acceptable limits for ambient temperature.
 - 3) Water-cooled heat exchangers requiring cleaning shall not be acceptable.
 - d. VFD Rating:
 - 1) Drive shall be suitable for continuous operation at nameplate voltage $\pm 10\%$.
 - 2) Drive shall be suitable for continuous operation at 100% of nameplate

Guide specifications (cont)



amps and 150% of nameplate amps for 5 seconds.

- 3) Drive shall comply with applicable ANSI, NEMA, UL and NEC standards.
- 4) Drive shall be suitable for operation in ambient temperatures between 40 and 104 F, 95% humidity (non-condensing) for altitudes up to 6000 feet (1829 m) above sea level. Specific drive performance at jobsite ambient temperature and elevation shall be provided by the manufacturer in the bid.

e. User Interface:

A single display shall provide interface for programming and display of VFD and chiller parameters. Viewable parameters include:

- 1) Operating, configuration and fault messages
- 2) Frequency in hertz
- 3) Load and line side voltage and current (at the VFD)
- 4) kW (line and load side)
- 5) IGBT temperatures

f. VFD Performance:

- 1) VFD Voltage Total Harmonic Distortion (THD) and Harmonic Current Total Demand Distortion (TDD) shall not exceed IEEE-519 requirements using the VFD circuit breaker input terminals as the point of common coupling (PCC).
- 2) VFD full load efficiency shall meet or exceed 97% at 100% VFD Rated Ampacity.
- 3) Active rectifier shall regulate unity displacement power factor to 0.99 or higher at full load.
- 4) Voltage boost capability to provide full motor voltage at reduced line voltage conditions.
- 5) Soft start, linear acceleration, coast to stop.
- 6) Base motor frequency shall be either 50 or 60 hertz. Adjustable frequency range from 39 to 60 hertz or 32.5 to 50 hertz.

g. VFD Electrical Service (single point power):

- 1) VFD shall have input circuit breaker with minimum 65,000 amp interrupt capacity.
- 2) VFD shall have standard 15 amp branch circuit breaker to provide power for chiller oil pump.
- 3) VFD shall have standard 3 kva control power transformer with circuit breaker provides power for oil heater, VFD controls and chiller controls.
- 4) The branch oil pump circuit breaker and control power transformer shall be factory wired.

- 5) Nameplate voltage shall range between 380 to 460 $\pm 10\%$, 3 phase, 50/60 Hz $\pm 2\%$ Hz.

h. Discrete Outputs:

115 v discrete contact outputs shall be provided for field wired:

- 1) Chilled water pump
- 2) Condenser water pump
- 3) Alarm status
- 4) Tower fan low
- 5) Tower fan high

i. Analog Output:

An analog (4 to 20 mA) output for head pressure reference shall be provided. This signal shall be suitable to control a 2-way or 3-way water regulating valve in the condenser piping.

j. Protection (the following shall be supplied):

- 1) Under-voltage
- 2) Over voltage
- 3) Phase loss
- 4) Phase reversal
- 5) Ground fault
- 6) Phase unbalance protection
- 7) Single cycle voltage loss protection
- 8) Programmable auto re-start after loss of power
- 9) Motor overload protection (NEMA Class 10)

k. VFD Testing:

VFD shall be factory mounted, wired and tested on the chiller prior to shipment.

24. Unit-Mounted Variable Frequency Drive (VFD) without Built-In Harmonic Filter:

a. Design:

- 1) VFD shall be refrigerant cooled, micro-processor based, pulse width modulated design. Water cooled designs are not acceptable.
- 2) Output power devices shall be insulated gate bipolar transistors (IGBTs).
- 3) Converter section with full-wave fixed diode bridge rectifier shall convert incoming fixed voltage/frequency to fixed DC voltage.
- 4) DC link shall filter and smooth the converted DC voltage.
- 5) Transistorized inverter and control regulator shall convert fixed DC voltage to a sinusoidal PWM waveform.
- 6) Integrated controls shall coordinate motor speed and guide vane position to optimize chiller performance over a wide variety of operating conditions.
- 7) Surge prevention and surge protection algorithms shall take action to prevent surge and move chiller operation away from surge.



b. Enclosure:

- 1) Pre-painted unit mounted, NEMA 1 cabinet shall include hinged, lockable doors and removable lifting lugs.
- 2) VFD shall have a short circuit interrupt and withstand rating of at least 100,000 amps.
- 3) Provisions to padlock main disconnect handle in the "Off" positions shall be provided. Mechanical interlock to prevent opening cabinet door with disconnect in the "On" position or moving disconnect to the "ON" position while the door is open shall be provided.
- 4) Provisions shall be made for top entry of incoming line power cables.

c. Heat Sink:

- 1) The heat sink shall be refrigerant cooled. Heat sink and mating flanges shall be suitable for ASME design working pressure of 185 psig (1276 kPa).
- 2) Refrigerant cooling shall be metered by integrated standard controls to maintain heat sink temperature within acceptable limits for ambient temperature.

d. VFD Rating:

- 1) Drive shall be suitable for nameplate voltage $\pm 10\%$.
- 2) Drive shall be suitable for continuous operation at 100% of nameplate amps and 150% of nameplate amps for 3 seconds.
- 3) Drive shall comply with applicable UL, CE, and NEMA standards.
- 4) Drive shall be suitable for operation in ambient temperatures between 40 and 104 F, 95% humidity (non-condensing) for altitudes up to 3300 feet (1006 m) above sea level. Specific drive performance at jobsite ambient temperature and elevation shall be provided by the manufacturer in the bid.

e. User Interface:

Displays shall provide interface for programming and display of VFD and chiller parameters. Viewable parameters include:

- 1) Operating, configuration and fault messages
- 2) Frequency in hertz
- 3) Load and line side voltage and current (at the VFD)
- 4) kW (on the VFD interface)

f. VFD Performance:

- 1) VFD full load efficiency shall meet or exceed 97% at 100% VFD Rated Ampacity.

- 2) Displacement Input Power Factor shall meet or exceed 95% soft start, linear acceleration, coast to stop.

- 3) Base motor frequency shall be either 50 or 60 hertz. Adjustable frequency range from 38 to 60 hertz or 32.5 to 50 hertz.

g. VFD Electrical Service: (single point power):

- 1) VFD shall have input circuit breaker with minimum 100,000 amp interrupt capacity.

- 2) VFD shall have standard 15 amp branch oil pump circuit breaker to provide power for chiller oil pump.

- 3) VFD shall have standard 3 kva control power transformer with circuit breaker provides power for oil heater, VFD controls and chiller controls.

- 4) The branch oil pump circuit breaker and control power transformer shall be factory wired.

- 5) Input power shall be 380/480 vac, ± 10 percent, 3 phase, 50/60 Hz, ± 3 Hz.

h. Discrete Outputs:

115-v discrete contact outputs shall be provided for:

- 1) Circuit breaker shunt trip
- 2) Chilled water pump
- 3) Condenser water pump
- 4) Alarm status.

i. Analog Output:

An analog (4 to 20 mA) output for head pressure reference shall be provided. This signal shall be suitable to control a 2-way or 3-way water regulating valve in the condenser piping.

j. Protection (the following shall be supplied):

- 1) Under-voltage
- 2) Over voltage
- 3) Phase loss
- 4) Phase reversal
- 5) Ground fault
- 6) Phase unbalance protection
- 7) Single cycle voltage loss protection
- 8) Programmable auto re-start after loss of power
- 9) Motor overload protection (NEMA Class 10)
- 10) Motor over temperature protection

k. VFD Testing:

VFD shall be factory mounted, wire and tested on the chiller prior to shipment.

