



Product Data

AIRSTREAM™ 40UV,UH050-200 Unit Ventilators

500 to 2000 Nominal Cfm

AIRSTREAM™

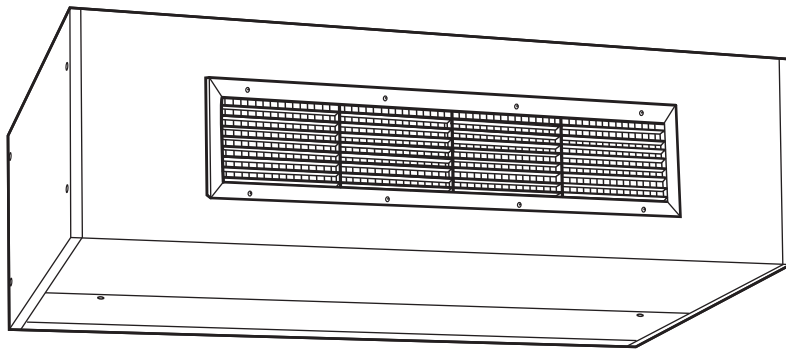

40UH

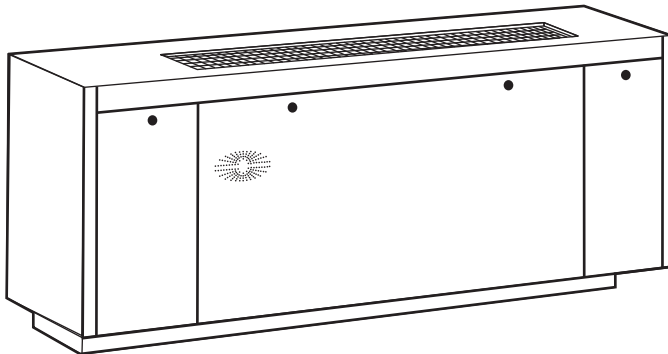

40UV

Carrier delivers unit ventilators that meet the strict indoor air quality requirements of schools, hospitals, and institutions.

- Vertical and horizontal designs provide heating, cooling and dehumidification solutions for a variety of applications
- Quiet fan system offers an ideal solution for sound-sensitive applications, such as classrooms
- Dehumidification capabilities, air filtration techniques, and a sealed insulation design ensure indoor air quality
- Modular design provides enhanced structural rigidity for long trouble-free operation and simplified maintenance
- Chilled water, hot water, steam and DX (direct expansion) coils are constructed of aluminum fins mechanically bonded to copper tubes for peak heat transfer (electric resistance heating is also available)
- Heavy gage, die-formed galvanized steel frame ensures rugged dependability, exact panel fit, precise component alignment and long-term structural integrity
- Tamper resistant hex head panel fasteners offer easy service access without special tools
- Large compartments for wiring and piping simplify maintenance procedures

Features/Benefits

The 40UV and 40UH unit ventilators are compact, efficient, and easy to install.

The superior design features of 40UV and 40UH units provide economical, dependable, long-term performance.

Features/Benefits (cont)



Indoor air quality

The combination of features found in 40UV and 40UH unit ventilators ensures that only clean, healthy, conditioned air is delivered to the occupied space. Ventilation rate is certified per AHRI (Air Conditioning, Heating, and Refrigeration Institute) Standard 840 by an independent laboratory.

One-piece filter cleans the air before it is introduced into the room. Unit is shipped with a 1-in. throwaway filter and can accept permanent or renewable media filters. Filter track may be adjusted to accept field-supplied 2-in. filter.

Combination outdoor/return air damper, standard on all units, provides positive control of ventilation air. Extruded aluminum damper is insulated with closed cell foam insulation.

Double sloped condensate drain pan can be configured for right-hand or left-hand drain connection in the field. Drain connection size $\frac{7}{8}$ in. OD copper.

Cooling coil has a full-depth design. When combined with available face and bypass damper, the coils prevent the build-up of humidity in the room, even during part load conditions.

Precision fan system provides quiet operation in environments where sound control is critical, such as classrooms. Sound level is certified by an independent laboratory per AHRI Standard 350.

Die-formed, heavy-gage steel cabinet provides secure, dent-resistant protection for internal components. Cabinet exterior has a baked-on polyurethane powder-coated finish for corrosion resistance and enhanced appearance.

Front access panels are secured with hex-head fasteners to provide tamper-resistance while maintaining easy maintenance and service access.

Efficient direct-drive motor prevents alignment problems. Blowers share a common hollow shaft connected to the motor with a resilient coupling.

Steel blower housings are securely mounted to a die-formed galvanized steel blower deck.

Self-aligning bearings, vibration isolating motor mounts and flexible drive shaft coupling isolate the rotating components from the rest of the unit to ensure quiet vibration-free operation.

Mechanically bonded aluminum fin coils provide improved heat transfer with corrosion and vibration resistance. Copper tubes are standard.

UNIT VENTILATOR CONSTRUCTION

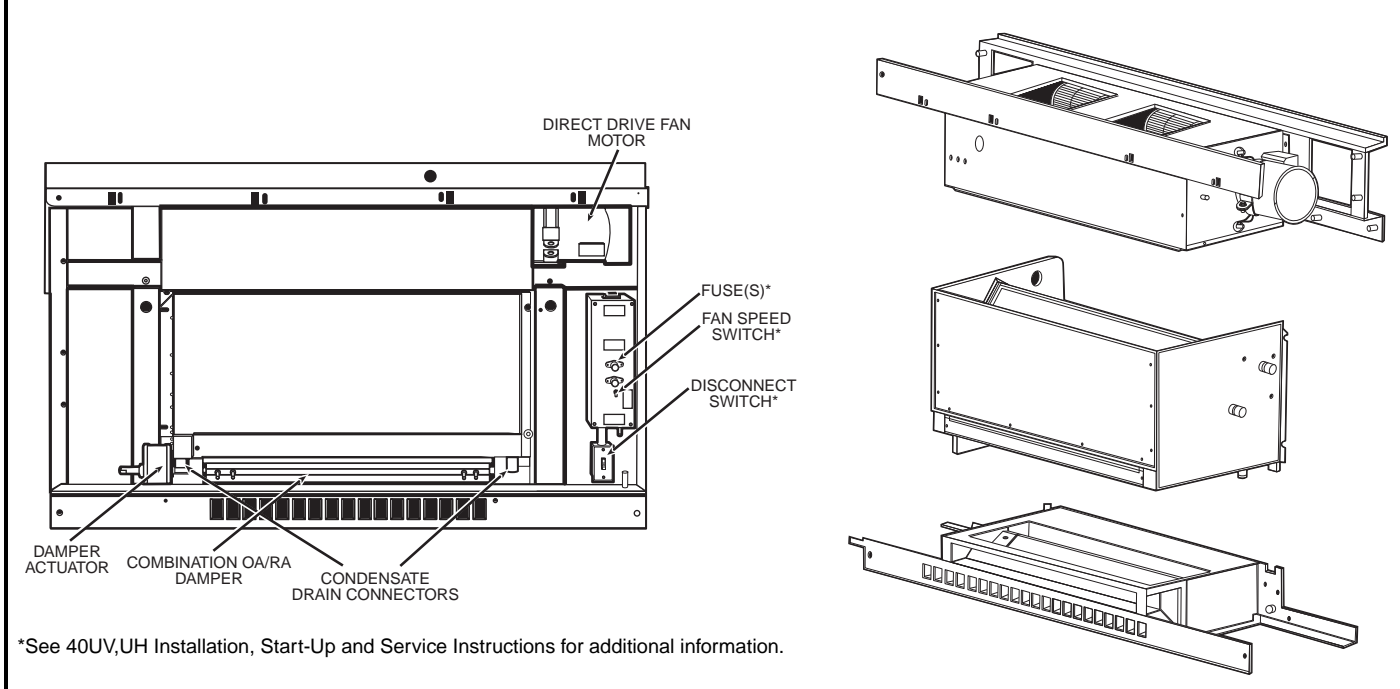

*See 40UV,UH Installation, Start-Up and Service Instructions for additional information.



Enhanced performance and safety

Draw-thru blower arrangement distributes air across entire coil face for uniform discharge temperatures. Draw-thru design also eliminates hot spots in electric heat coil to maximize heating element life.

Efficient direct drive helps to maintain low operating costs and also reduces maintenance requirements.

Wide selection of factory-installed coils includes chilled and hot water, DX, steam, and electric resistance heat coils.

Motor and control protection is provided by cartridge fuses. Units are ETL listed to UL Standard 1995.

Safety cutouts and interlock switches ensure safe performance. Fan must be operating before optional

electric heat is turned on. Electric heat is turned off in case of high-heat conditions.

Economical operation

The 40UV and 40UH Series unit ventilators not only have low initial costs, but they also save money by reducing installation expense and providing long-term energy-efficient performance.

Quick installation provided by built-in levelers, drain pan connections on both ends of the unit, and reversible coil hand without unit modification.

Permanent split capacitor (PSC) motors are standard on size 50 to 150 units (500 through 1500 cfm).

Electronically commutated (ECM) blower motor option saves energy and overload protection with automatic reset ensures reliability. The ECM

motor is standard on all size 200 units (2000 cfm). The ECM motor is also provided for units with high static pressure application or units with the UV Open controller option or units with field supplied and installed controls. Motors are mounted out of the airstream so they are not subject to coil heat, extending the life of the motor.

High-efficiency, precision-balanced blowers minimize air turbulence, surging and vibration to minimize operating expenses.

Mixing dampers control the blend of outside air and room air to achieve comfort levels. When the outside air is suitable, outside air dampers can fully open to provide free cooling.

Fewer moving parts lower operating costs by enhancing reliability and making service easier.

Table of contents

	Page
Features/Benefits	1-3
Model Number Nomenclature	4-9
AHRI Capacity Ratings	10
Physical Data	10
Options and Accessories	11-13
Base Unit Dimensions	14-24
Accessory Dimensions	25-45
Selection Procedure	45
Performance Data	46-77
Electrical Data	78-84
Application Data	85-89
Guide Specifications	90-94

Model number nomenclature



BASE UNIT MODEL NUMBER

40 UV F 3 P 1 A A B 1 2 2 M 0 J 1 C B F G B F A 1 A

40 – Unit Ventilator

UV – Vertical
UH – Horizontal

Design
F – UH/UV Current Design

Code	Unit Size	Nominal Cfm
1	050	500 (UV only)
2	075	750
3	100	1000
4	125	1250
5	150	1500
6	200	2000 (UH only)

Paint Options

UV,UH Units with Colored Panels (Charcoal Bronze Top for UV Only)	UV Units with Same Colored Panels and Top	Colors
P	1	Polar Ice
B	2	Beige
G	3	Gray
W	4	White
Z (UH Only)	5	Charcoal Bronze

Access Panel Gage

1 – Standard 16 Gage (UV units only)
2 – Heavy Duty 14 Gage (UV units only)
A – 18 Gage (UH units only)

End Panel Kit Options (1-in. Thick)

A – None or for UH Designation
B – 16 $\frac{1}{4}$ in. x 30 in. Standard Solid End Panel
C – 16 $\frac{1}{4}$ in. x 30 in. with 2 $\frac{1}{2}$ in. x 7 in. Cutout
D – 16 $\frac{1}{4}$ in. x 30 in. with 4 in. x 18 in. Cutout
E – 16 $\frac{1}{4}$ in. x 30 in. with 4 in. x 22 in. Cutout
F – 21 $\frac{1}{4}$ in. x 30 in. Standard Solid End Panel
G – 21 $\frac{1}{4}$ in. x 30 in. with 2 $\frac{1}{2}$ in. x 7 in. Cutout
H – 21 $\frac{1}{4}$ in. x 30 in. with 4 in. x 18 in. Cutout
J – 21 $\frac{1}{4}$ in. x 30 in. with 4 in. x 22 in. Cutout
K – 21 $\frac{1}{4}$ in. x 30 in. with 5 $\frac{1}{4}$ in. x 2 $\frac{1}{2}$ in. Cutout

Inlet Arrangements

Horizontal Units

A – Bottom RA, Top OA D – Rear RA, Top OA
B – Bottom RA, Rear OA E – Rear RA, Rear OA
C – Bottom RA, No OA F – Rear RA, No OA

Vertical Units

16 $\frac{5}{8}$ in. CABINET, FRONT RA	16 $\frac{5}{8}$ in. CABINET DRAFT STOP RA	DESCRIPTION
A	L	Rear OA, Open Piping Tunnel
B	M	Rear OA, Closed Piping Tunnel
C	N	Bottom OA, Open Piping Tunnel
D	O	No OA, Open Piping Tunnel

21 $\frac{7}{8}$ in. CABINET, FRONT RA	21 $\frac{7}{8}$ in. CABINET DRAFT STOP RA	DESCRIPTION
E	P	Rear OA, Piping Passage Unit
F	R	Rear OA, Full Adapter Back
G	S	Top OA, Full Adapter Back
H	T	Bottom OA, Open Adapter Back
I	U	No OA, Open Adapter Back
J	W	2 $\frac{1}{2}$ in. Step Down Pipe Pass Adapter Back
K	Y	2 $\frac{1}{2}$ in. Step Down Full Adapter Back

**SEE NEXT PAGE
FOR REMAINDER
OF MODEL
NUMBER
NOMENCLATURE**

Temperature Control Type

A – No Controls
D-H – DDC Ready
J-3 – Carrier UV Open Controls
X – Factory-Installed Controls by Others

Outdoor Air Damper

1 – Standard Damper Assembly
2 – Standard Damper Assembly with Locking Quadrant
3 – Cold Weather Damper Assembly
4 – Cold Weather Damper Assembly with Locking Quadrant
5 – No Outdoor Air Damper (Recirculation Only)

Face and Bypass Damper

1 – No Damper
2 – Face and Bypass Damper

Fan Motor Selection

1 – PSC - Standard
2 – ECM - High-Efficiency Motor
5 – ECM - Variable Speed Motor

Discharge Air

Horizontal Units

A – Front Discharge Bar Stock Grille*
B – Front Discharge Grille with Screen*
C – Front Discharge Duct Collar (No Grille)*
D – Front Discharge Duct Collar with Plenum (No Grille)†
E – Front Discharge Double Deflection Grille with Plenum†
F – Bottom Discharge with Double Deflection Grille**

Vertical Units

A – Top Discharge Bar Stock Steel Grille
B – Top Discharge Grille with Screen
C – Top Discharge Duct Collar (No Grille)

See next page for legend and footnotes.



BASE UNIT MODEL NUMBER (cont)

40 UV F 3 P 1 A A B 1 2 2 M 0 J 1 C B F G B F A 1 A

**SEE PREVIOUS PAGE
FOR REMAINDER
OF MODEL
NUMBER
NOMENCLATURE**

0 – Not Used

Power Supply / Disconnect

- J** – 115-1-60 (Standard)
- K** – 208-1-60
- L** – 240-1-60
- M** – 277-1-60
- 5** – 208-3-60 (3-Wire)
- 6** – 240-3-60 (3-Wire)
- 7** – 460-3-60 (3-Wire)

Coil Arrangements

- 1** – H/W Position 1, C/W Position 2 (PreHeat)
- 2** – H/W Position 2, C/W Position 1 (ReHeat)

Heating Coil Type

- A** – None
- B-J** – Hot Water Same End Connections
- M-R** – Steam Same End Connections
- S-W** – Steam Opposite End Connections
- 3-6** – Electric Heat Right Hand Coil Connection

Warranty

- A** – One Year

Filter Option

- 1** – 1-in. Throwaway Filter
- 2** – 1-in. Renewable Filter
- 3** – 1-in. Permanent Filter
- 4** – 2-in. Pleated Filter

Drain Pan Option

- A** – Galvanized Drain Pan
- B** – Stainless Steel Drain Pan

Cooling Valve Piping Package

- A** – None
- B-E** – Packages used with 2-Way Valve
- F-J** – Packages used with 3-Way Valve
- X** – 2 or 3-Way Special Piping Package

Cooling Valve / Actuator

- A** – None
- B-G** – 3-Way Modulating Valve / Actuator
- H** – 3-Way, 2-Position Valve††
- J-O** – 2-Way Modulating Valve / Actuator
- P** – 2-Way, 2-Position Valve††

Cooling Coil Type

- A** – None
- F-L** – Cold Water Same End Connections
- 8,9** – C/W High Capacity Same End Connections
- Y,Z,2,3** – Direct Expansion

Heating Valve Piping Package

- A** – None
- B-E** – Packages used with 2-Way Valve
- F-J** – Packages used with 3-Way Valve
- X** – 2 or 3-Way Special Piping Package

Heating Valve / Actuator

- A** – None
- B-G** – 3-Way Modulating Valve / Actuator
- H** – 3-Way, 2-Position Valve††
- J-O** – 2-Way Modulating Valve / Actuator
- P** – 2-Way, 2-Position Valve††
- 1-6** – Steam, 2-Way Modulating Valve / Actuator
- P** – Steam, 2-Way, 2-Position Valve

LEGEND

- DDC** – Direct Digital Controls
- ECM** – Electronically Commutated Motor
- OA** – Outside Air
- PSC** – Permanently-Split Capacitor
- RA** – Return Air

*Available for 30¹/₂ in. horizontal units only.

†Available for 36 in. (40 in. for size 200) horizontal units only.

**Available for 40 in. (44 in. for size 200) horizontal units only.

††Face and bypass units only.

Model number nomenclature (cont)



STORAGE CABINET PART NUMBERS*

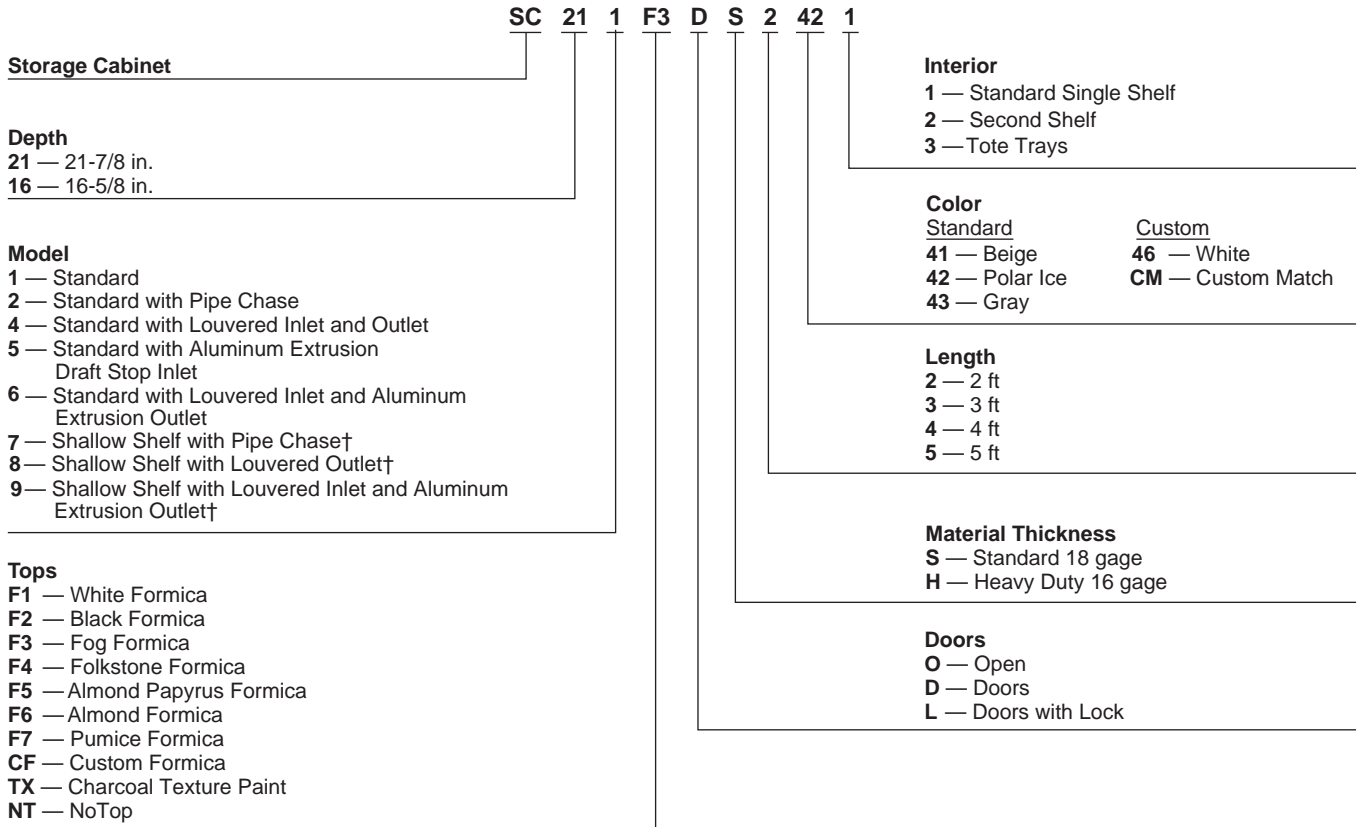

FILLER SECTION PART NUMBERS*

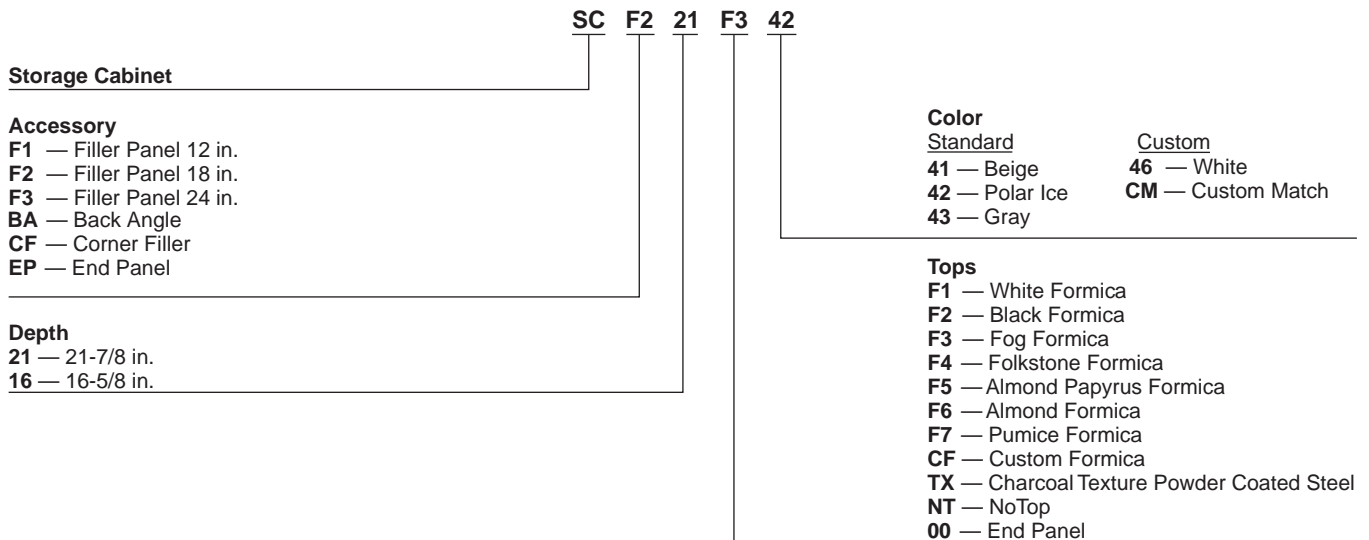

*To order, contact your Carrier Sales representative.
†Available for 16⁵/₈ in. depth only.



DRAFT STOP PART NUMBERS*

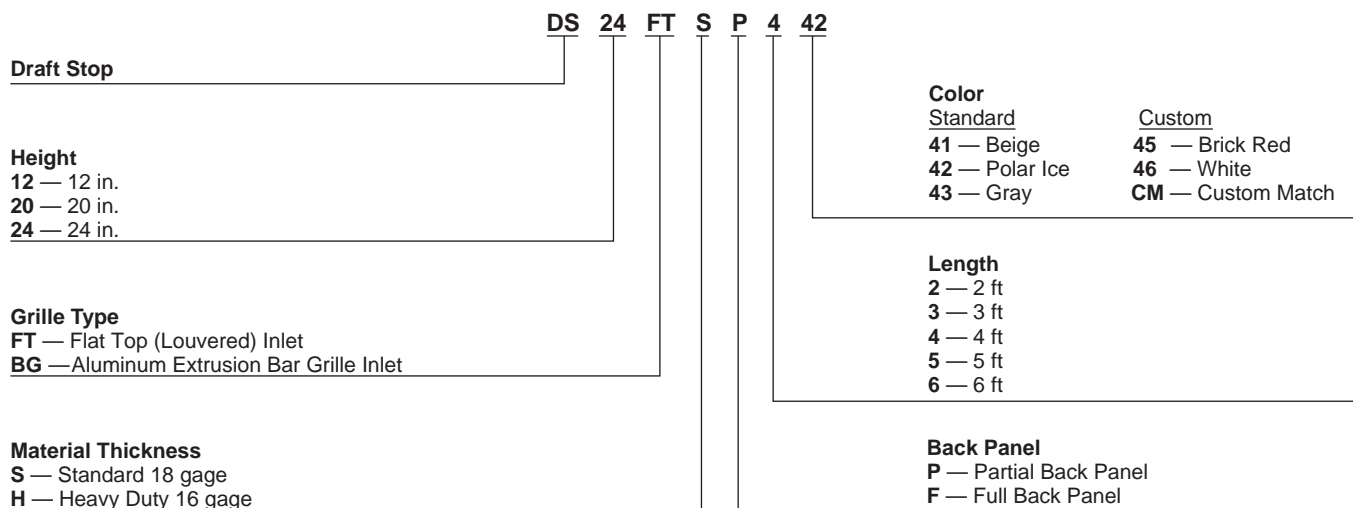

DRAFT STOP ACCESSORY PART NUMBERS*

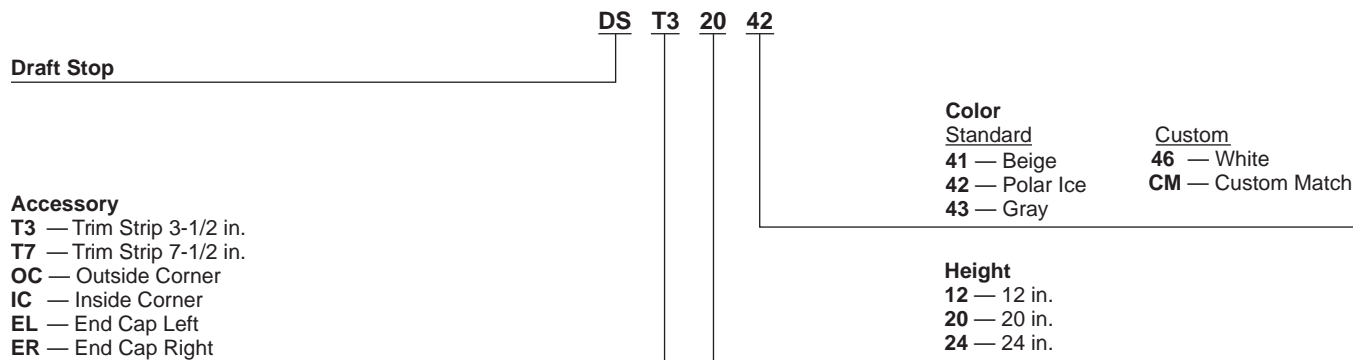

*To order, contact your Carrier Sales representative.

Model number nomenclature (cont)



PIPE ENCLOSURE PART NUMBERS*

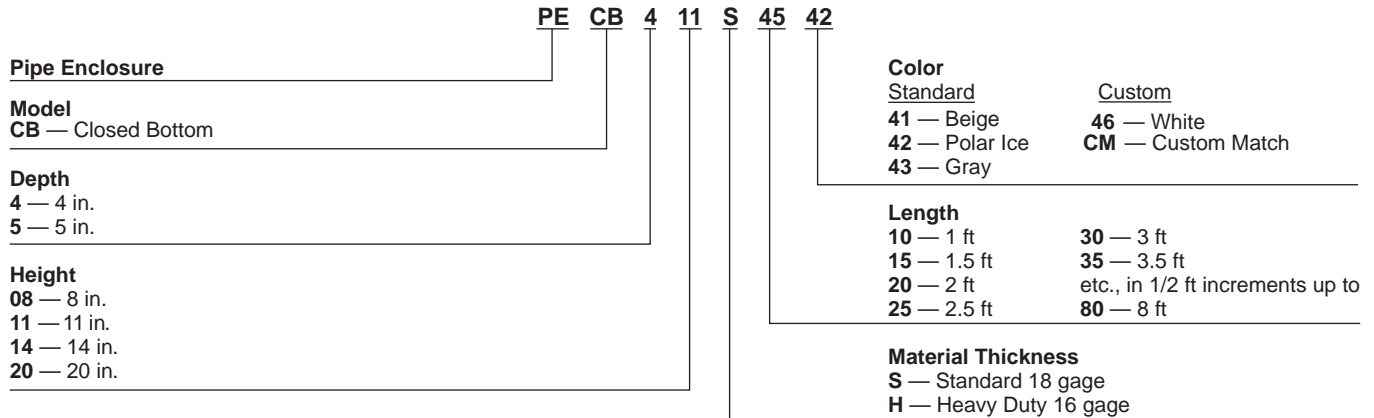

PIPE ENCLOSURE ACCESSORY PART NUMBERS*

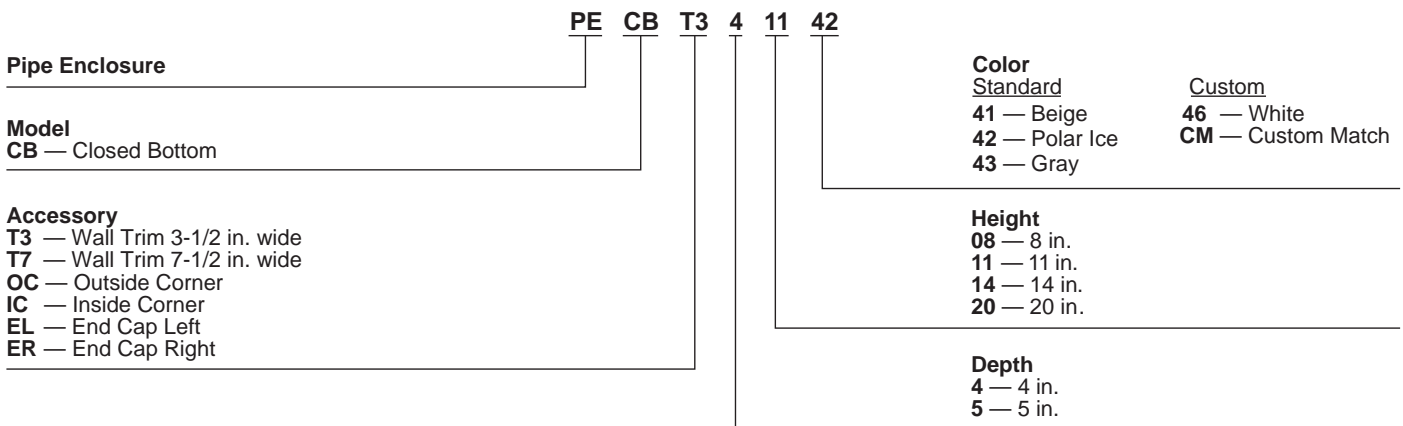

*To order, contact your Carrier Sales representative.



SINK AND BUBBLER PART NUMBERS*

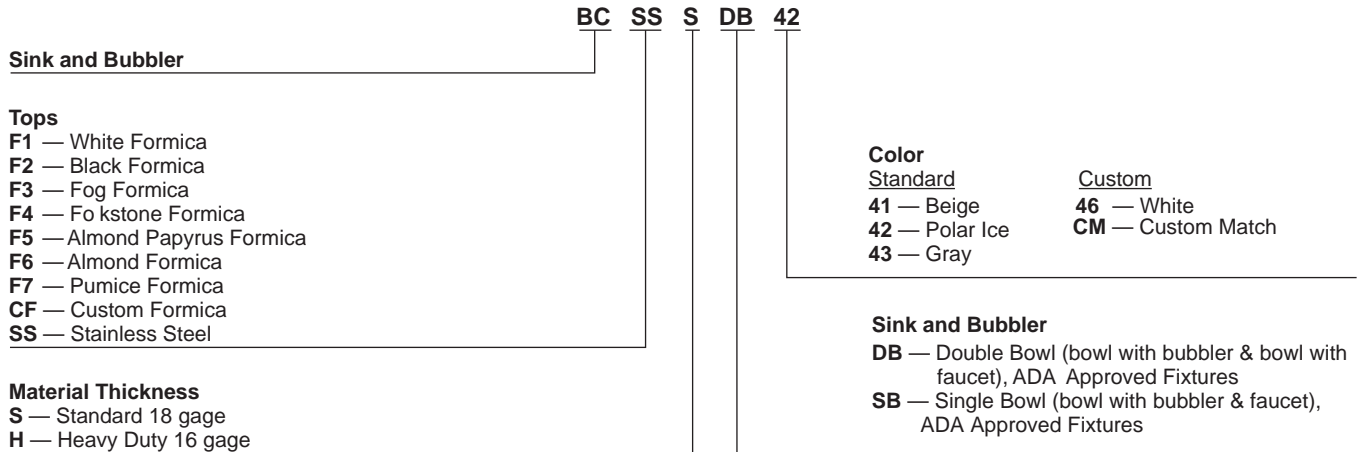

ADA — Americans with Disabilities Act

TOUCH-UP PAINT PART NUMBERS*

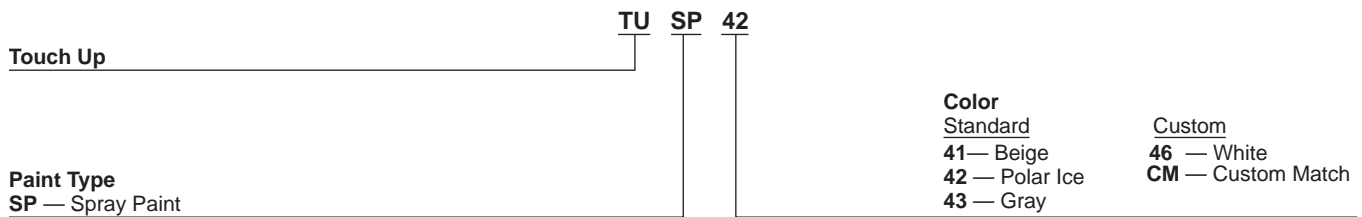

*To order, contact your Carrier Sales representative.

AHRI* capacity ratings



40UV,UH UNIT SIZE	NOMINAL CFM	ACTUAL CFM	TOTAL (Btuh)	SENSIBLE CAPACITY (Btuh)	VENTILATION RATE (%)
050†	500	490	8,300	6,400	80
075	750	750	19,400	12,900	80
100	1000	1000	26,300	19,100	80
125	1250	1210	33,500	23,600	80
150	1500	1500	40,200	28,100	80
200**	2000	2010	65,000	42,000	80

*Air Conditioning, Heating, and Refrigeration Institute.

†40UV only.

**40UH only.

NOTES:

1. Ratings are in accordance with AHRI Standard 840.
2. All units are equipped with a 3-row coil.
3. Water temperature rise is 10 F, with entering water temperature of 45 F.
4. Entering air temperature is 80 F dry bulb, 67 F wet bulb.



Physical data

40UV,UH

UNIT 40UV,UH	050*	075	100	125	150	200†
NOMINAL AIRFLOW (Cfm)	500	750	1000	1250	1500	2000
FANS						
Quantity	1	2	3	4	5	5
Diameter (in.)	8.32	8.32	8.32	8.32	8.32	9.5
Width (in.)	8	8	8	8	8	6
40UV FILTERS						
Nominal Size (in.) (1 in. thick)	9 ¹ / ₄ x 24 ¹ / ₄	9 ¹ / ₄ x 36 ¹ / ₄	9 ¹ / ₄ x 48 ¹ / ₄	9 ¹ / ₄ x 60 ¹ / ₄	9 ¹ / ₄ x 72 ¹ / ₄	—
Nominal Size (in.) (2 in. thick)	9 ¹ / ₄ x 24 ¹ / ₄	9 ¹ / ₄ x 36 ¹ / ₄	9 ¹ / ₄ x 48 ¹ / ₄	9 ¹ / ₄ x 60 ¹ / ₄	9 ¹ / ₄ x 72 ¹ / ₄	—
Quantity	1	1	1	1	1	—
40UH FILTERS						
Nominal Size (in.) (1 in. thick)	—	9 ³ / ₄ x 36 ¹ / ₄	9 ³ / ₄ x 48 ¹ / ₄	9 ³ / ₄ x 60 ¹ / ₄	9 ³ / ₄ x 72 ¹ / ₄	9 ³ / ₄ x 72 ¹ / ₄
Nominal Size (in.) (2 in. thick)	—	9 ³ / ₄ x 36 ¹ / ₄	9 ³ / ₄ x 48 ¹ / ₄	9 ³ / ₄ x 60 ¹ / ₄	9 ³ / ₄ x 72 ¹ / ₄	9 ³ / ₄ x 72 ¹ / ₄
Quantity	—	1	1	1	1	1
40UV SHIPPING WEIGHT**						
(Approx lb)						
16 ⁵ / ₈ in. Deep Unit	330	400	480	590	660	—
21 ⁷ / ₈ in. Deep Unit	340	410	490	605	675	—
40UH SHIPPING WEIGHT**						
(Approx lb)						
34 in. Deep Unit	—	420	500	620	690	—
39 ¹ / ₂ in. Deep Unit	—	500	600	740	830	—
43 ¹ / ₂ in. Deep Unit	—	530	640	790	880	1020
47 ¹ / ₂ in. Deep Unit	—	—	—	—	—	1050
40UV INSTALLED WEIGHT**						
(Approx lb)						
16 ⁵ / ₈ in. Deep Unit	315	380	460	570	640	—
21 ⁷ / ₈ in. Deep Unit	325	390	470	595	655	—
40UH INSTALLED WEIGHT**						
(Approx lb)						
34 in. Deep Unit	—	405	480	600	670	—
39 ¹ / ₂ in. Deep Unit	—	485	580	720	810	—
43 ¹ / ₂ in. Deep Unit	—	515	620	770	860	1000
47 ¹ / ₂ in. Deep Unit	—	—	—	—	—	1030
COIL WATER WEIGHT						
(Approx lb per row of coil)	1.0	1.5	2.0	2.4	2.7	2.7
COIL CONNECTIONS (in. OD)						
Water Coils with 1 to 5 Rows		Return			Supply	
Steam Coils (All Units)		7/8			7/8	
		7/8			1 1/8	
		Suction			Liquid	
		7/8			3/8	
DX Coils						
CONDENSATE DRAIN						7/8

LEGEND

DX — Direct Expansion

*40UV only.

†40UH 43 1/2 and 47 1/2 in. deep units only.

**Weight based on damper-controlled unit with 5-row coil and factory-installed controls.

Options and accessories



40UV, UH OPTIONS AND ACCESSORIES

ITEM	OPTION*	ACCESSORIES†	ACCESSORIES**
Adapter Back	X		
Bar Stock with Screen	X		
UV Open Controls	X		
Chilled Water Coil	X		
DDC Ready Controls	X		
Discharge Duct Collar	X		
Double Deflection Grille	X		
Draft Elimination Return	X		
DX Coils	X		
ECM Motor	X		
Electric Resistance Heat Coils	X		
Face and Bypass Damper	X		
Heavy Gage Exterior Panel	X		
Hot Water Coil	X		
Outside Air Damper	X		
Paint Color	X		
Pipe Tunnel	X		
Stainless Steel Drain Pan	X		
Steam Coil	X		
Filters	X	X	
Barometric Relief Damper		X	
Barometric Relief Damper Louver		X	
End Panels		X	
Outside Air Louvers		X	
Unit Subbase		X	
Utility Compartment		X	
Valve Package		X	
Draft Stop Enclosure			X
Filler Section			X
IAQ Sensor (CO ₂)			X
Pipe Enclosure			X
Power Exhauster			X
Sink and Bubblers			X
Storage Cabinet			X
Temperature Sensors			X
Touch-Up Paint			X

LEGEND

- DDC** — Direct Digital Controls
- DX** — Direct Expansion
- ECM** — Electrically Commutated Motor
- IAQ** — Indoor Air Quality
- UV** — Unit Vent

*Factory-installed option.

†Factory-supplied, field-installed option.

**Field-installed or factory-supplied, field-installed option with an ETO (Engineered to Order) request.

Options and accessories (cont)



Factory-installed options

Controls are factory-mounted, factory-wired and factory-tested. Direct Digital Control (DDC) packages can be provided for a variety of unit configurations and comply with ASHRAE (American Society of Heating, Refrigerating and Air Conditioning Engineers) control cycle I, II, or III recommendations. These controls provide integrated system operation and are compatible with Carrier's i-Vu® Open control system or a BACnet* building automation system. Carrier's Unit Vent Open Controller is an integrated component of a Carrier unit ventilator. The Unit Vent Open controller continuously monitors and regulates unit ventilator operation with reliability and precision. This advanced controller features a sophisticated, factory-engineered control algorithm that provides optimum performance and energy efficiency. The Unit Vent Open controller also features plug-and-play connectivity to Carrier's i-Vu Open Control System. The Carrier i-Vu Open Control System combines state-of-the-art Carrier equipment, plug-and-play controllers, and the powerful, web-based i-Vu user interface to form a cohesive, intuitive, and fully integrated BACnet Building Automation System. For added flexibility, the Unit Vent Open controller is capable of stand-alone operation. Application features include built-in advanced control routines for zone level demand control ventilation and automatic fan speed control based on actual heating or cooling requirements. System benefits include demand limiting support for maximum energy savings. Hardware features include on-board hardware clock, remote occupancy input, and support for space temperature thermistor sensor for stand alone operation.

For additional information on the Unit Vent Open factory-mounted controller, refer to product data sheet 11-808-469-01 and installation and start-up guide catalog no. 11-808-476-01. Factory-mounted controls supplied by others are also available by special request.

Three standard ventilation cycles:

- ASHRAE Cycle I: Admits 100% outdoor air at all times.
- ASHRAE Cycle II: Most common control cycle.
- ASHRAE Cycle III: Variable outdoor-air cycle.

NOTE: Factory-installed controls by other option must be quoted on a job-by-job basis. Factory may wire controls and actuator based on request. However, setting the actuator (switch settings, tightening clamp to damper shaft, torque pre-loading, etc.) is the responsibility of the customer.

Direct Digital Controls (DDC) ready control package option is a pre-wired offering of selected control components. These components are factory-wired to a terminal strip located in the left-hand end package of the unit ventilator.

The unit is shipped from the factory with an ETL listing, in addition to the following features:

- A NEC (National Electrical Code) Class 2 type transformer.
- Double pole, single throw (DPST) fan start/stop capability.

- Outdoor air/return air actuator or face and bypass damper actuator: 3-point floating, 2 to 10 vdc or 4 to 20 mA.
- A chilled water or direct expansion cooling coil low temperature detection thermostat.

Discharge duct collar option allows easy ductwork mounting to horizontal unit discharge.

Electric resistance heat coils have capacities ranging from 4.2 to 24 kW and are factory-installed options. All heat coils have automatic and manual high limit cutouts.

Face and bypass damper is used to control the amount of air sent through the heating or cooling coils. The face and bypass damper is constructed of aluminum with double edge blade seals.

Filter options include permanent washable elements or renewable media with a frame. All filters are nominal 1-in. or 2-in. widths. Standard 1-in. filter track may be adjusted to accept field-supplied 2-in. filter.

Low-limit thermostat (LLT) is factory-installed and factory-wired on all units with water coils. The sensor shuts down the fan circuit if the mixed-air temperature falls below the factory setting of 38 F, which prevents the hydronic coils from freezing. The LLT, a 12-ft capillary tube in the airstream, provides SPDT contact and is mounted on the leaving-air side of the coil. When installed on DX coil units as a factory-installed option, the LLT operates when the temperature falls below 28 F.

Field-installed accessories

Barometric relief damper or power exhauster accessories can be used with the unit ventilator system to eliminate positive pressure in the building and promote better air exchange for indoor air quality.

Cabinet filler sections include top panels, end panels, inside corners and non-standard paint colors which provide hidden space for piping and controls, as well as functional counter space compatible with storage cabinets. Coordinated finishes ensure a seamless, custom appearance in the unit ventilator and architectural accessory installation.

Draft stop enclosure (draft eliminator) accessory draws unit ventilator inlet air along window walls to create a thermal barrier between the room and outside wall, eliminating cold window downdrafts and occupancy discomfort. Draft stop enclosures can stand alone or be incorporated into the back of storage cabinet sections.

Filter options include permanent washable elements or renewable media with a frame. All filters are nominal 1-in. or 2-in. widths. Standard 1-in. filter track may be adjusted to accept field-supplied 2-in. filter.

Indoor air quality (CO₂) sensor is available as a wall-mounted, field-installed accessory. The sensor uses infrared technology to detect the levels of CO₂ present in the conditioned space. This information is used to modify the position of the outdoor-air dampers to admit more outdoor air as required to provide the desired ventilation rate. An isolated field-supplied transformer is required to provide power to sensor.

*Sponsored by ASHRAE (American Society of Heating, Refrigerating and Air Conditioning Engineers).

Louvers are available for exterior wall openings in a variety of styles. Decorative grille accessory provides an architectural finish.

Pipe enclosure accessories carry and conceal supply and return piping to and from the unit ventilator. The accessories, available in the same color as the unit ventilator, contribute to a neat appearance by covering exposed piping.

Sink and bubbler units handle any type of classroom application. Compatible with storage cabinets and filler sections, they can also provide continuous surface area for the room perimeter installation.

Storage cabinets accommodate books and supply storage along window walls. Manufactured from tough cold-rolled steel, reinforced for additional strength, and finished with a durable powder coat, they will withstand the abuse of a classroom environment.

Temperature sensors are available for wall mounting. Accessory wall-mounted space temperature sensors are available for field installation and wiring.

Valve packages provide cooling and heating modulation for hydronic coils. Both 2-way and 3-way valve packages are available in a wide range of C_v factors and connection sizes. Pneumatic valves are not available.

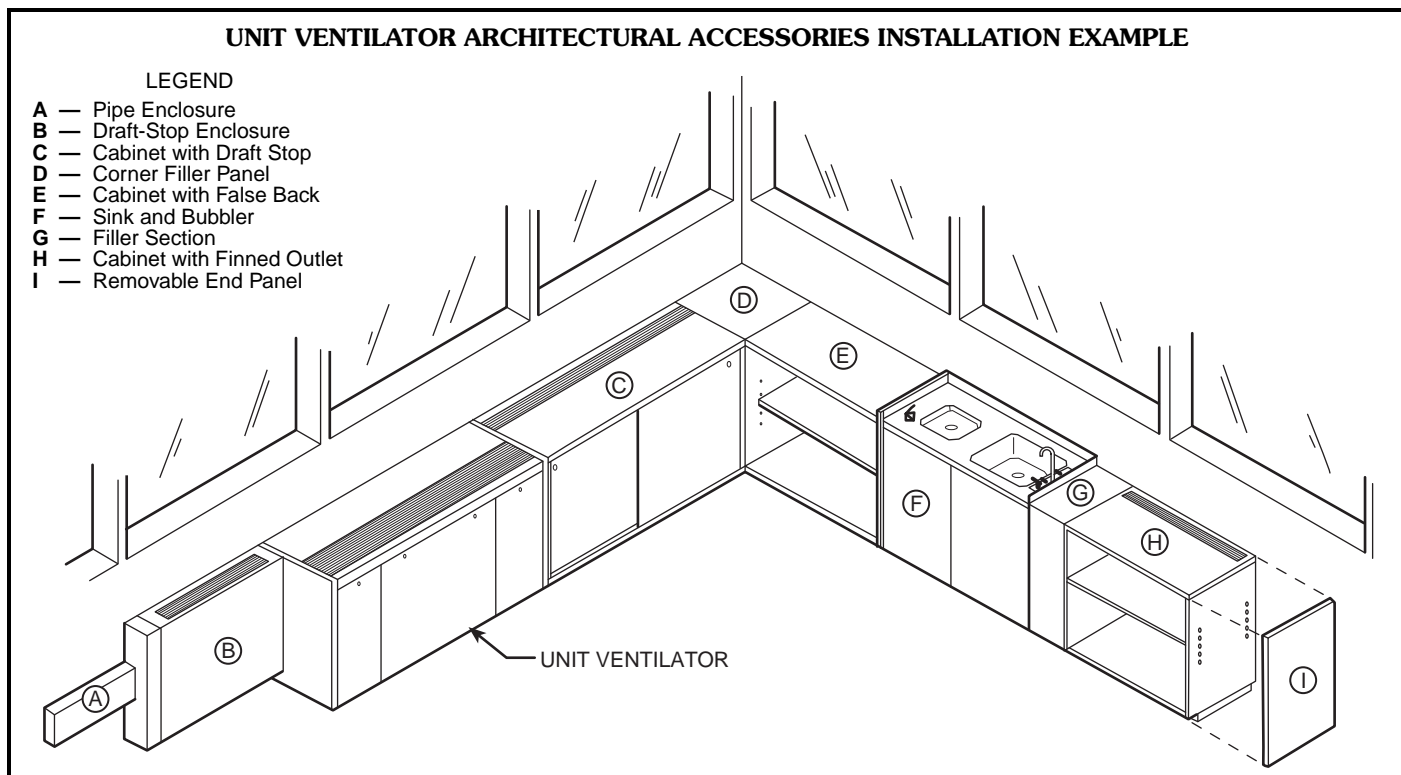

Base unit dimensions



40UV — 16⁵/₈-in. DEEP UNIT (STANDARD)

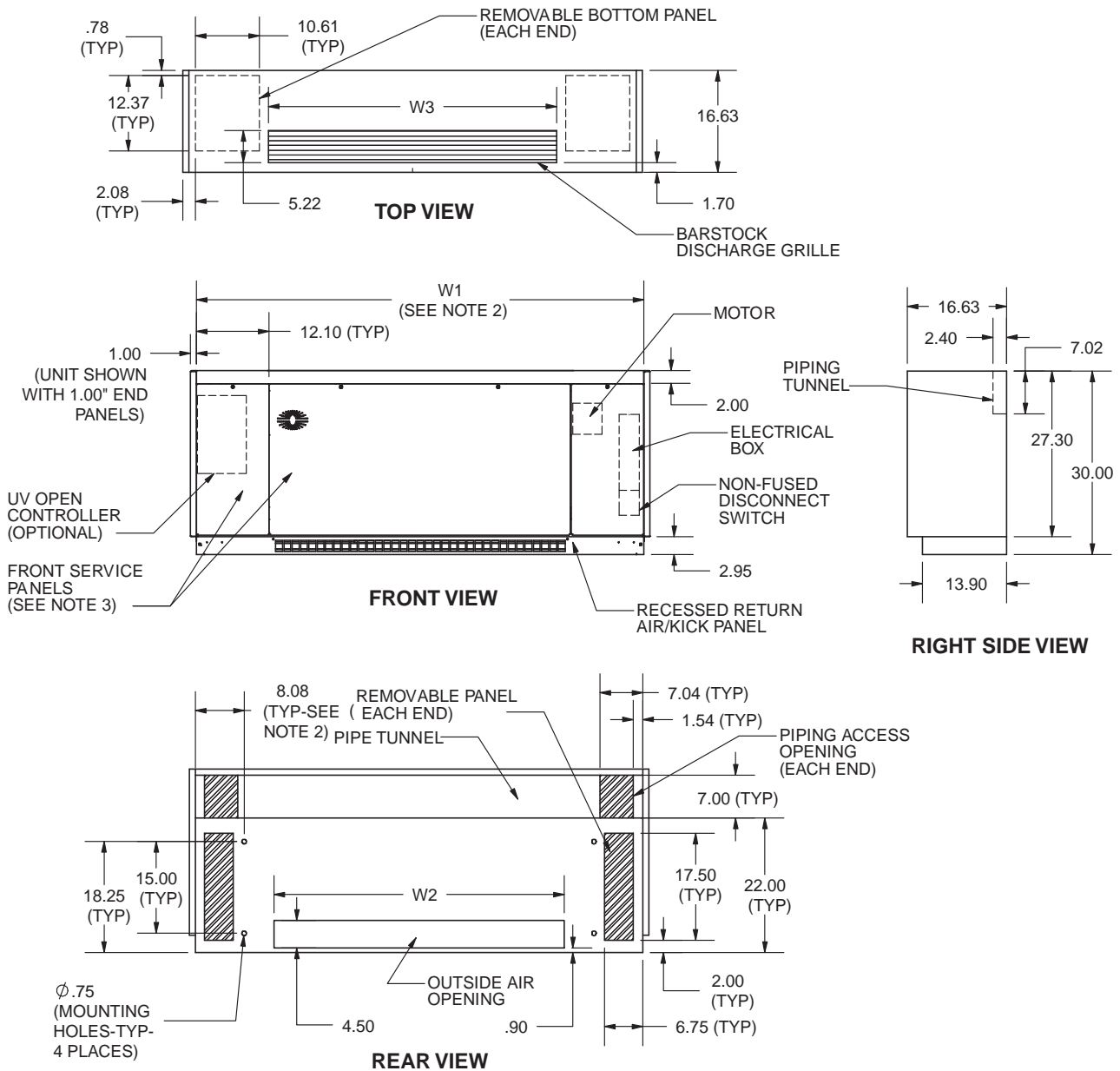

UNIT 40UV	AIRFLOW (cfm)	DIMENSIONS (in.)			APPROXIMATE SHIPPING WEIGHT (lb)	APPROXIMATE INSTALLED WEIGHT (lb)
		W1	W2	W3		
050	500	50	24	16.60	330	315
075	750	62	36	31.67	400	380
100	1000	74	48	46.74	480	460
125	1250	86	60	61.81	590	570
150	1500	98	72	78.47	660	640

NOTES:

1. All dimensions are in inches.
2. Dimension does not include end panels.
3. Three front panels provided for service access.
4. Motor and electrical power input box on right side of unit. Box includes fan speed switch, and non-fused disconnect switch.
5. Connection hand is determined by facing discharge of unit.

40UV — 21⁷/₈-in. DEEP UNIT

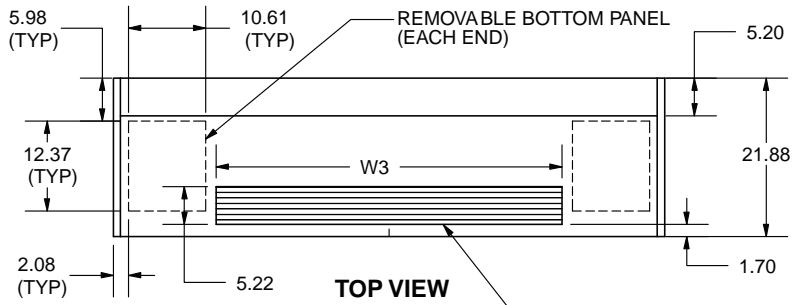

TOP VIEW

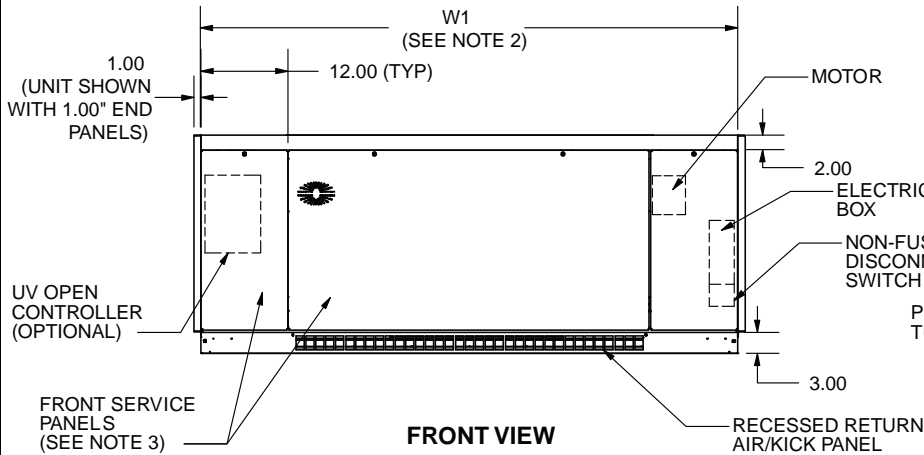

FRONT VIEW

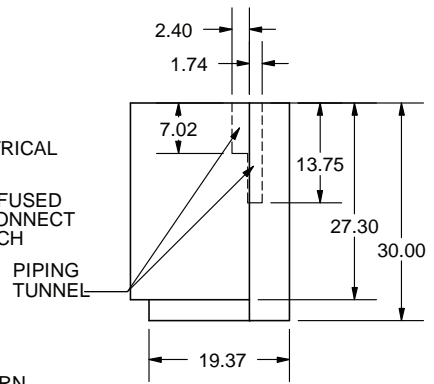

END VIEW

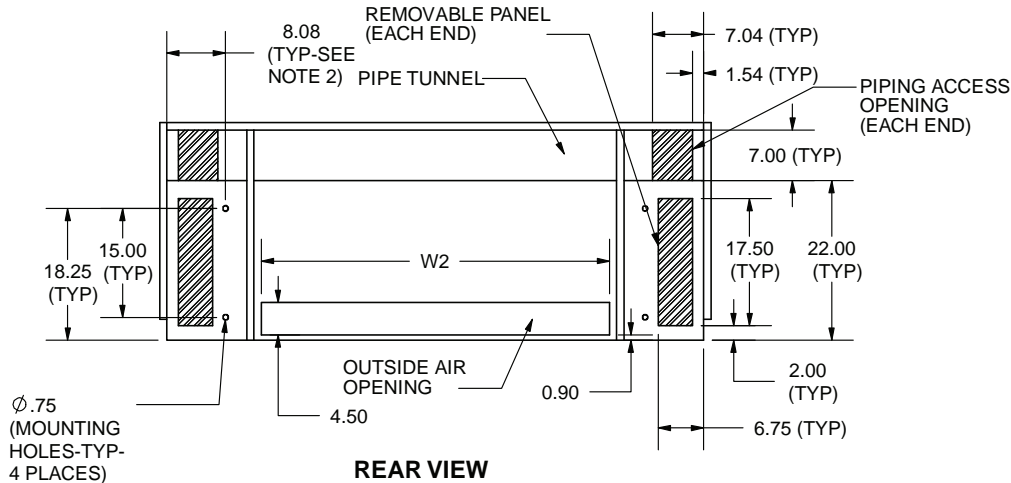

REAR VIEW

UNIT 40UV	AIRFLOW (cfm)	DIMENSIONS (in.)			APPROXIMATE SHIPPING WEIGHT (lb)	APPROXIMATE INSTALLED WEIGHT (lb)
		W1	W2	W3		
050	500	50	24	16.60	340	325
075	750	62	36	31.67	410	390
100	1000	74	48	46.74	490	470
125	1250	86	60	61.81	605	595
150	1500	98	72	78.47	675	655

NOTES:

1. All dimensions are in inches.
2. Dimension does not include end panels.
3. Three front panels provided for service access.
4. Motor and electrical power input box on right side of unit. Box includes fan speed switch, and non-fused disconnect switch.
5. Connection hand is determined by facing discharge of unit.

Base unit dimensions (cont)



40UH — 34-in. DEEP UNIT (Digit Code No. 11 - Option A/B/C)

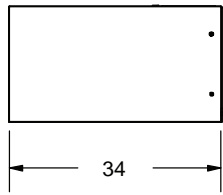

LEFT SIDE VIEW

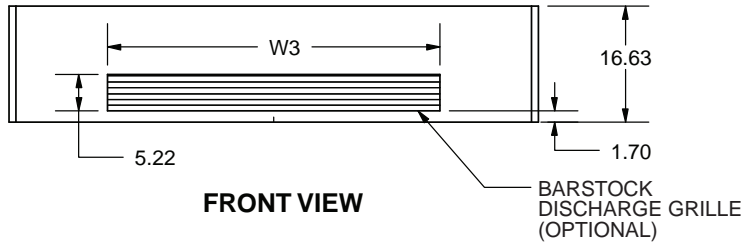

FRONT VIEW

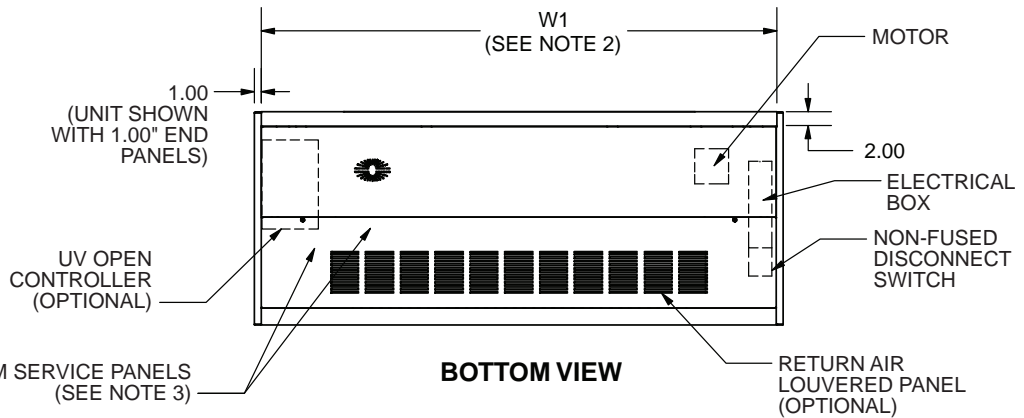

BOTTOM VIEW

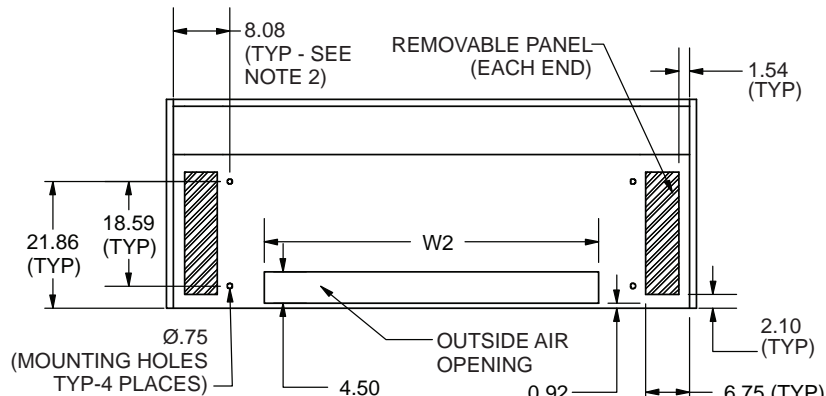

TOP VIEW

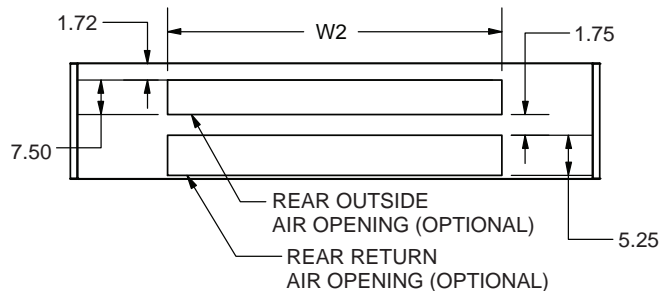

REAR VIEW

UNIT 40UH	AIRFLOW (cfm)	DIMENSIONS (in.)			APPROXIMATE SHIPPING WEIGHT (lb)	APPROXIMATE INSTALLED WEIGHT (lb)
		W1	W2	W3		
075	750	62	36	31.67	420	405
100	1000	74	48	46.74	500	480
125	1250	86	60	61.81	620	600
150	1500	98	72	78.47	690	670

NOTES:

1. All dimensions are in inches.
2. Dimension does not include end panels.
3. Two bottom panels provided for service access.
4. Motor and electrical power input box on right side of unit. Box includes fan speed switch, and non-fused disconnect switch.
5. Drawing refers to Design "F" units.

**40UH — 39 1/2 IN. AND 43 1/2 IN. DEEP UNITS WITH FRONT DISCHARGE PLENUM
(Digit Code No. 11 - Option D/E)**

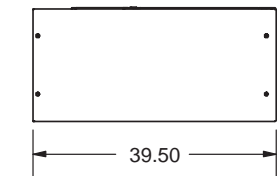

**LEFT SIDE VIEW
(SIZES 075 TO 150)**

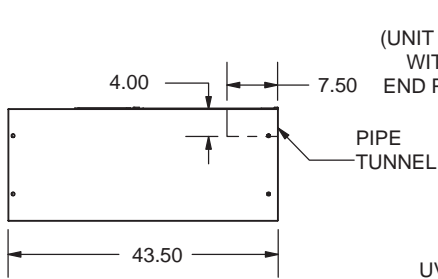

**LEFT SIDE VIEW
(SIZE 200)**

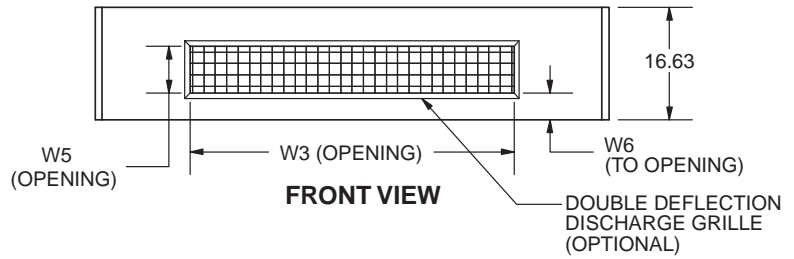

FRONT VIEW

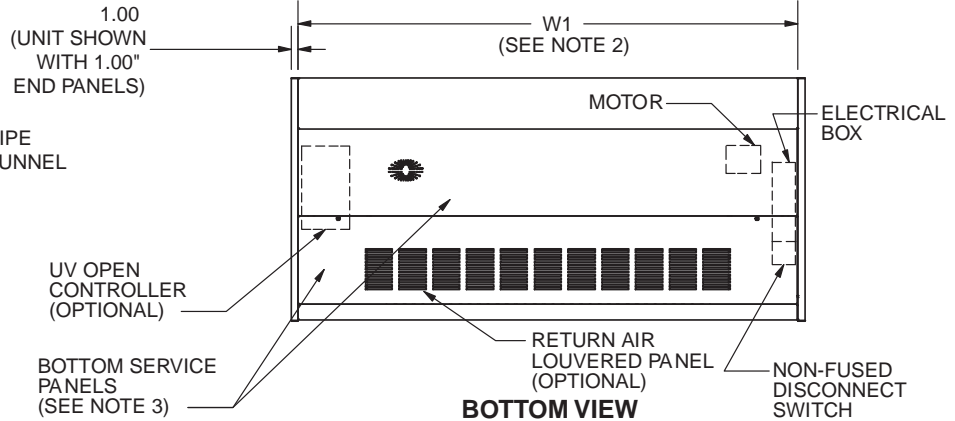

BOTTOM VIEW

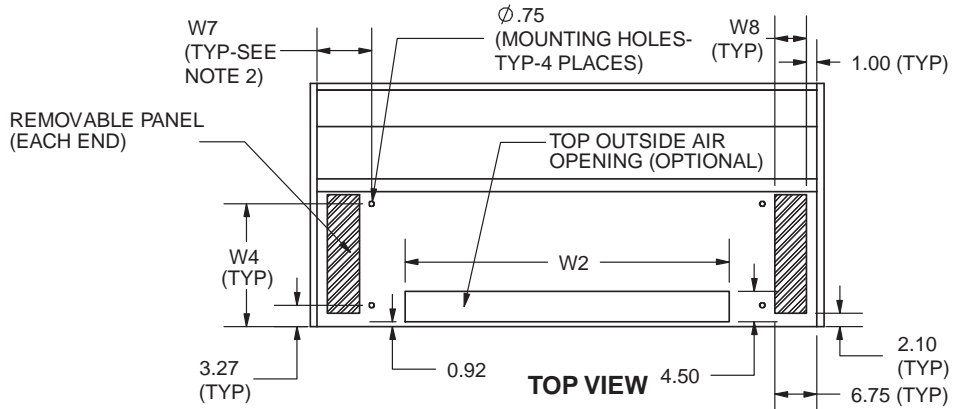

TOP VIEW

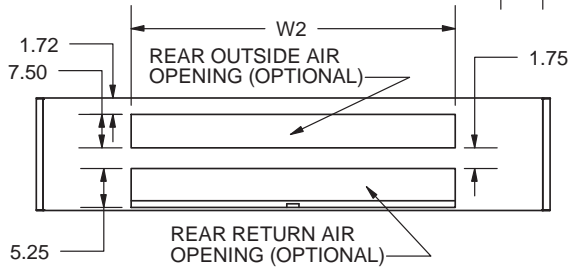

REAR VIEW

NOTES:

1. All dimensions are in inches.
2. Dimension does not include end panels.
3. Two bottom panels provided for service access.
4. Motor and electrical power input box on right side of unit. Box includes fan speed switch, and non-fused disconnect switch.
5. Connection hand is determined by facing discharge of unit.
6. Drawing refers to design "F" series.

UNIT 40UH	AIRFLOW (cfm)	DEPTH (in.)	DIMENSIONS (in.)								APPROXIMATE SHIPPING WEIGHT (lb)	APPROXIMATE INSTALLED WEIGHT (lb)
			W1	W2	W3	W4	W5	W6	W7	W8		
075	750	36	62	36	36	21.86	7.00	2.31	8.00	4.75	500	485
100	1000	36	74	48	48	21.86	7.00	2.31	8.00	4.75	600	580
125	1250	36	86	60	60	21.86	7.00	2.31	8.00	4.75	740	720
150	1500	36	98	72	72	21.86	7.00	2.31	8.00	4.75	830	810
200	2000	40	98	72	72	30.00	10.00	1.44	8.07	4.00	1020	1000

Base unit dimensions (cont)



40UH — 43¹/₂ IN. AND 47¹/₂ IN. DEEP UNITS WITH DOWN DISCHARGE PLENUM (Digit Code No. 11 - Option F)

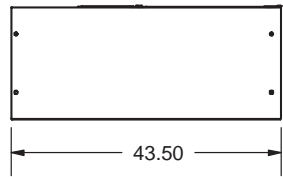

**LEFT SIDE VIEW
(SIZES 075 TO 150)**

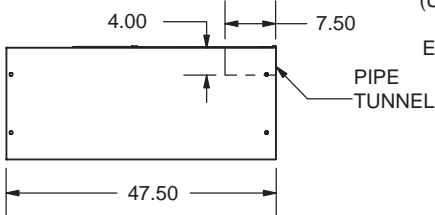

**LEFT SIDE VIEW
(SIZE 200)**



FRONT VIEW

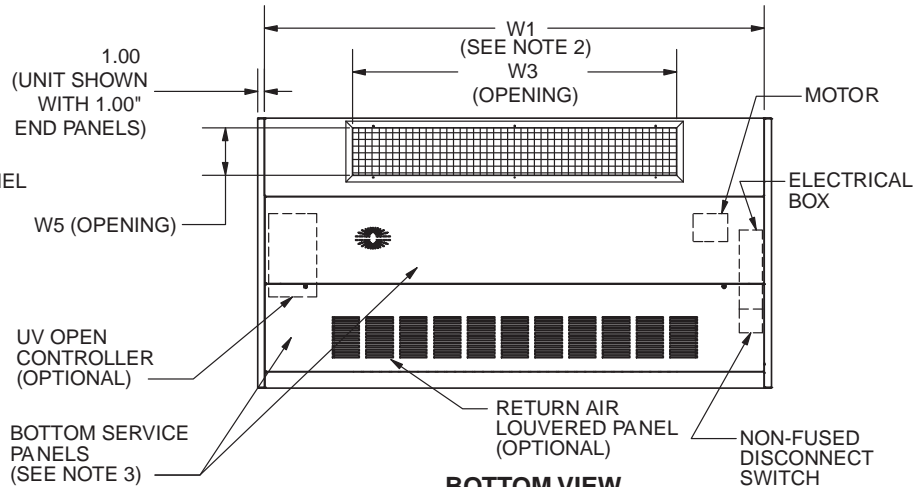

BOTTOM VIEW

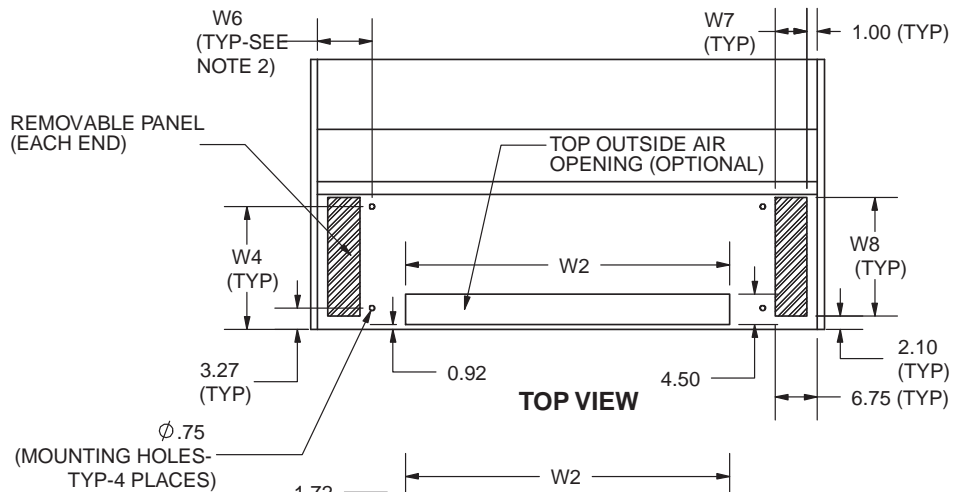

TOP VIEW

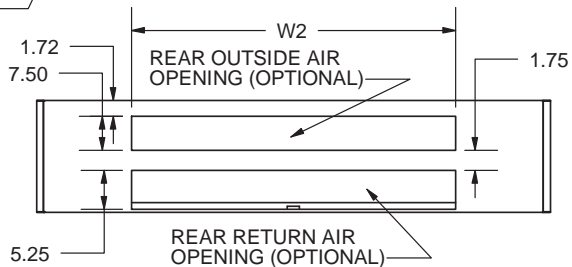

REAR VIEW

NOTES:

1. All dimensions are in inches.
2. Dimension does not include end panels.
3. Two bottom panels provided for service access.
4. Motor and electrical power input box on right side of unit. Box includes fan speed switch, and non-fused disconnect switch.
5. Connection hand is determined by facing discharge of unit.
6. Drawings refer to design "F" units.

UNIT 40UH	AIRFLOW (cfm)	DEPTH (in.)	DIMENSIONS (in.)							APPROXIMATE SHIPPING WEIGHT (lb)	APPROXIMATE INSTALLED WEIGHT (lb)
			W1	W2	W3	W4	W5	W6	W7		
075	750	40	62	36	36	21.86	7.00	8.00	4.75	530	515
100	1000	40	74	48	48	21.86	7.00	8.00	4.75	640	620
125	1250	40	86	60	60	21.86	7.00	8.00	4.75	790	770
150	1500	40	98	72	72	21.86	7.00	8.00	4.75	880	860
200	2000	44	98	72	72	30.00	10.00	8.07	4.00	1050	1030

COIL CONNECTIONS AND DIMENSIONS VERTICAL — HEATING/COOLING

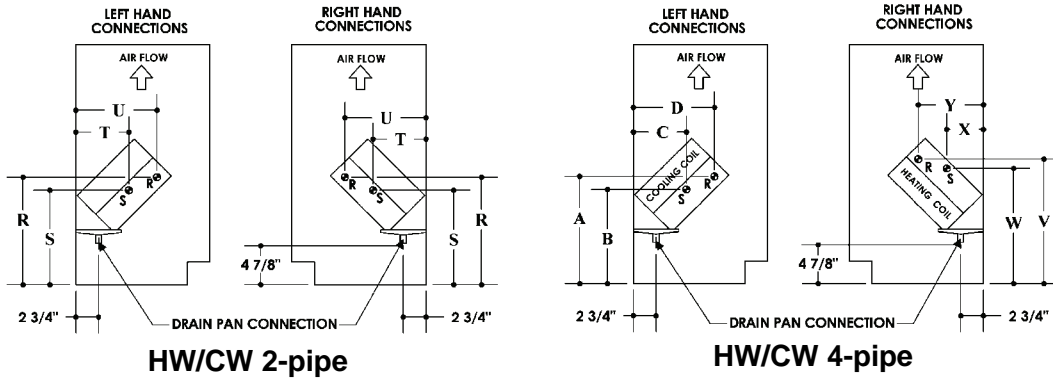

- LEGEND**
- CW** — Chilled Water
 - DX** — Direct Expansion
 - HW** — Hot Water
 - LL** — Liquid Line
 - SL** — Suction Line

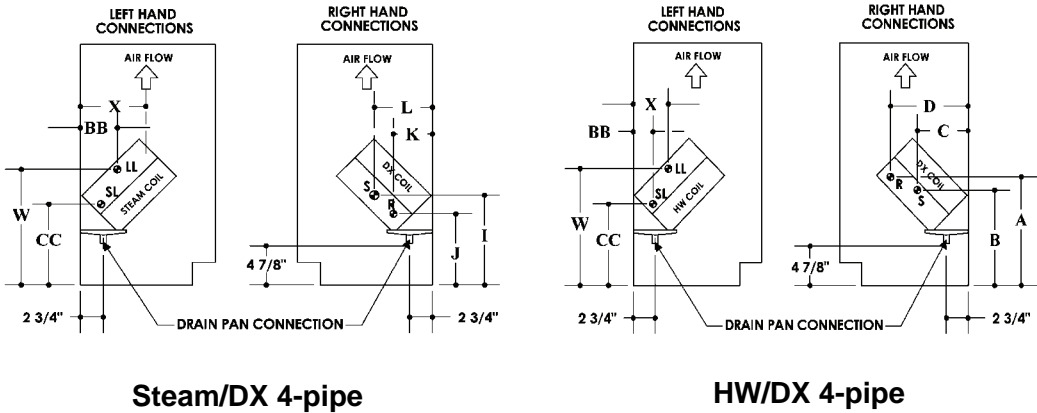
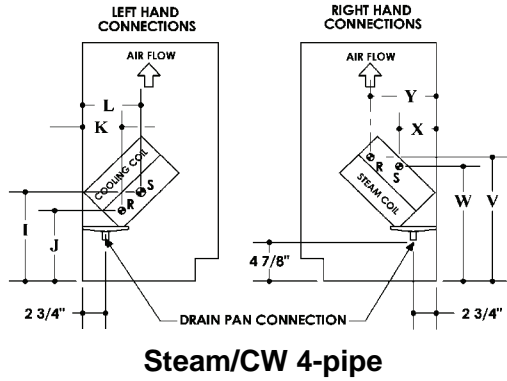

UNIT DEPTH (in.)	DIMENSIONS (in.)																	
	A	B	C	D	I	J	K	L	R	S	T	U	V	W	X	Y	BB	CC
16 ⁵ / ₈	13.72	11.40	7.64	11.19	11.45	9.11	5.13	7.47	13.72	11.94	6.95	11.18	16.33	14.55	4.35	8.58	2.70	10.36
21 ⁷ / ₈	13.72	11.40	12.89	16.44	11.45	9.11	10.38	12.72	13.72	11.94	12.20	16.43	16.33	14.55	9.60	13.83	7.95	10.36

Base unit dimensions (cont)



COIL CONNECTIONS AND DIMENSIONS (cont) VERTICAL — HEATING ONLY

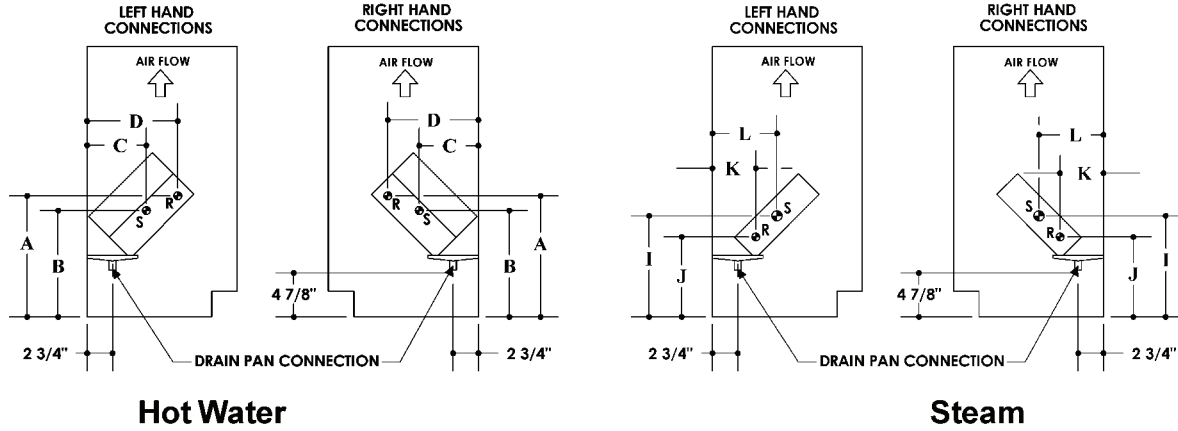

VERTICAL — COOLING ONLY

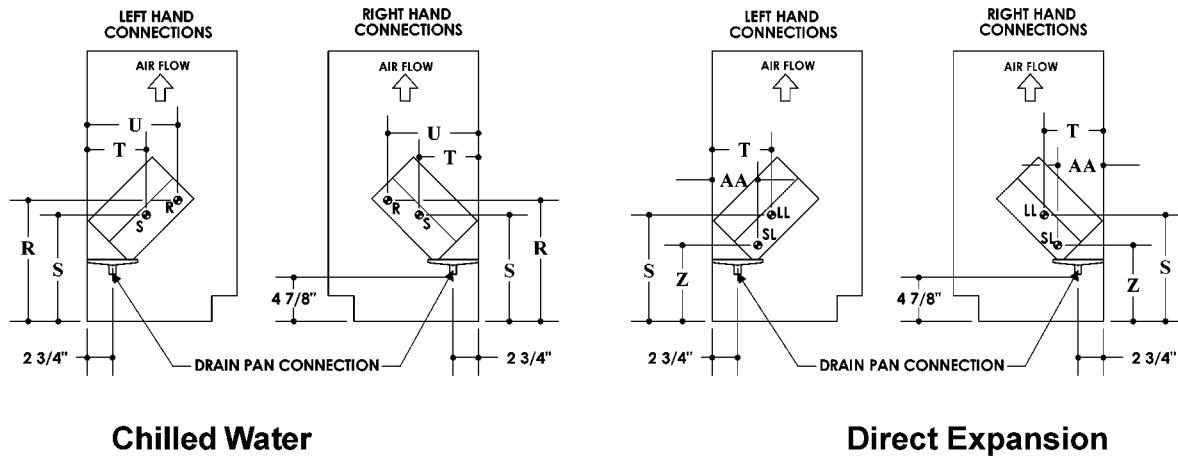

LEGEND

- LL — Liquid Line
- SL — Suction Line

UNIT DEPTH (in.)	DIMENSIONS (in.)													
	A	B	C	D	I	J	K	L	R	S	T	U	Z	AA
16 ⁵ / ₈	13.72	11.40	7.64	11.19	11.45	9.11	5.13	7.47	13.72	11.94	6.95	11.18	7.26	5.30
21 ⁷ / ₈	13.72	11.40	12.89	16.44	11.45	9.11	10.38	12.72	13.72	11.94	12.20	16.43	7.26	10.55

NOTES:

1. All coils have same end supply and return connections, except opposite end steam and direct expansion (see Note 10).
2. Opposite hand steam coil return lines are the same dimension as same hand but are located on side opposite the supply.
3. Steam coils have a factory-installed vacuum breaker for pressure equalization, which must be field terminated downstream from the steam trap.
4. Steam/hot water connections may be same end as cooling coil connections, but they are recommended to be opposite end to facilitate piping. (Must be opposite end when ordering factory valve packages.)
5. Cooling condensate connection is shipped same end as cooling coil connections, but is field reversible.
6. Electric heating coil power connections are right end only.
7. See tables on page 76 for limitations with coil combinations.
8. Water coil connections are 7/8 in. OD and terminate 9 in. from the end of the unit.
9. Steam coils supply is 1 1/8 in. OD condensate return line is 7/8 in. OD and terminate 9 in. from the end of the unit.
10. Direct expansion coils have female sweat connections. Interconnecting tube by others. Liquid lines are 3/8 in. OD and suction lines are 7/8 in. OD.

COIL CONNECTIONS AND DIMENSIONS (cont)
VERTICAL — REHEAT COOLING/HEATING

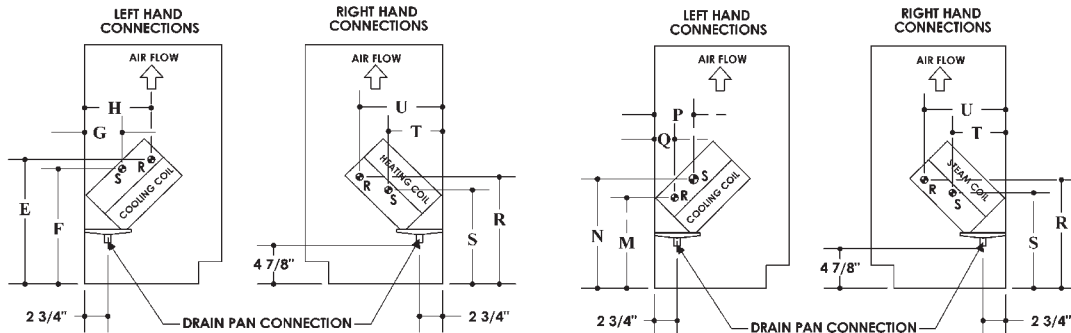

CW/HW 4-pipe

CW/Steam 4-pipe

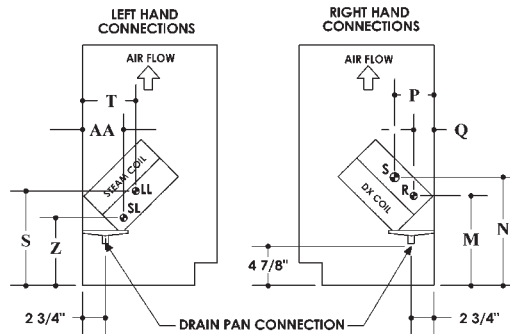

DX/Steam 4-pipe

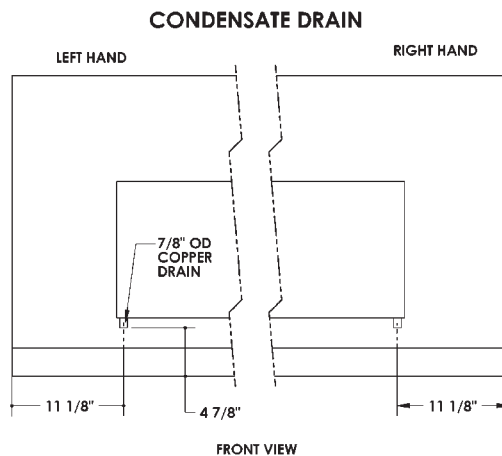

- LEGEND**
- CW** — Chilled Water
 - DX** — Direct Expansion
 - HW** — Hot Water
 - LL** — Liquid Line
 - SL** — Suction Line

UNIT DEPTH (in.)	DIMENSIONS (in.)													
	E	F	G	H	M	N	P	Q	R	S	T	U	Z	AA
16 ⁵ / ₈	16.95	14.62	4.41	7.97	11.54	13.88	5.05	2.71	13.72	11.94	6.95	11.18	7.26	5.30
21 ⁷ / ₈	16.95	14.62	9.66	13.22	11.45	13.88	10.30	7.96	13.72	11.94	12.20	16.43	7.26	10.55

Base unit dimensions (cont)



COIL CONNECTIONS AND DIMENSIONS (cont) HORIZONTAL — HEATING/COOLING

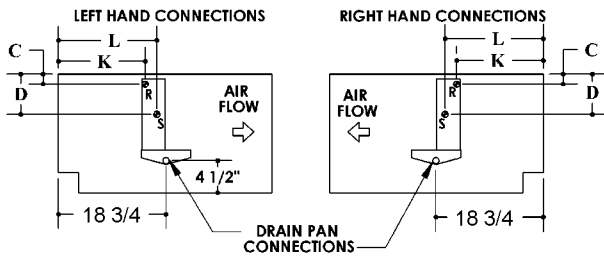

HW/CW 2-pipe

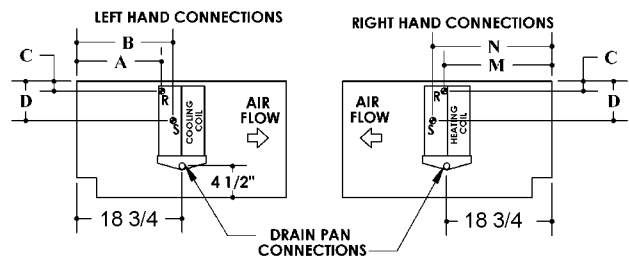

HW/CW 4-pipe

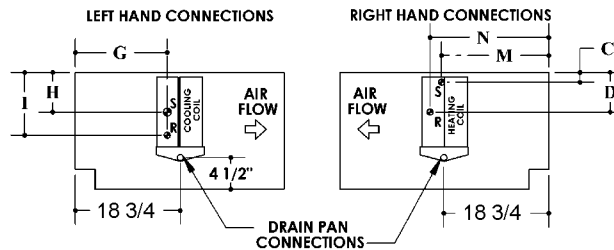

Steam/CW 4-pipe

- LEGEND**
- CW — Chilled Water
 - DX — Direct Expansion
 - HW — Hot Water
 - LL — Liquid Line
 - SL — Suction Line

NOTE: Dimensions based on Design "F" units.

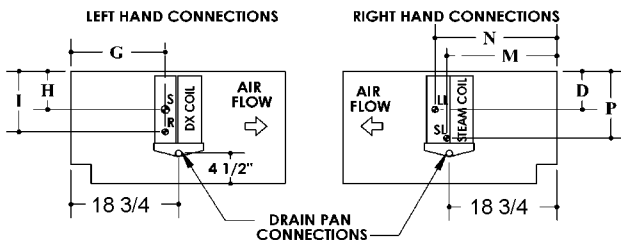

Steam/DX 4-pipe

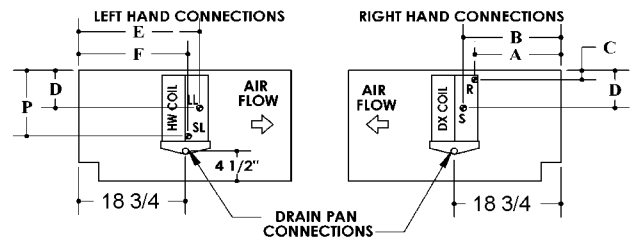

HW/DX 4-pipe

DIMENSIONS (in.)

A	B	C	D	E	F	G	H	I	K	L	M	N	P
16.0	16.8	1.4	5.7	20.1	19.3	17.0	5.9	9.2	16.4	18.3	18.4	19.9	9.9

COIL CONNECTIONS AND DIMENSIONS (cont)
HORIZONTAL — HEATING ONLY

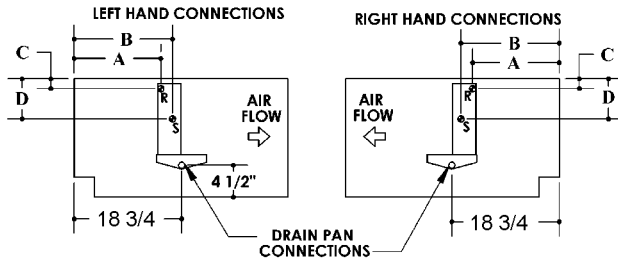

HOT WATER

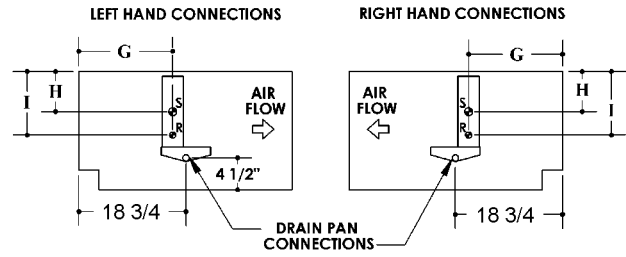

STEAM

HORIZONTAL — COOLING ONLY

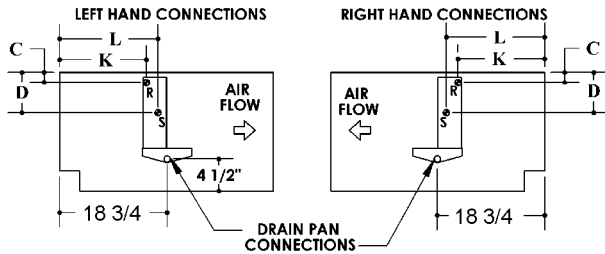

CHILLED WATER

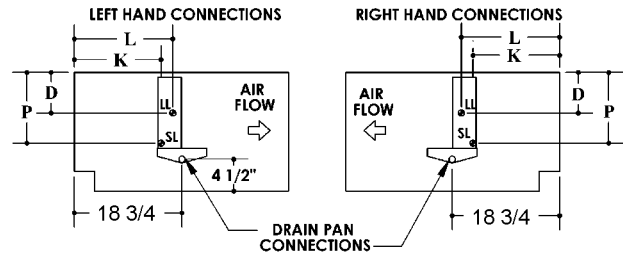

DIRECT EXPANSION

LEGEND

- LL** — Liquid Line
- SL** — Suction Line

DIMENSIONS (in.)

A	B	C	D	G	H	I	K	L	P
16.0	16.8	1.4	5.7	17.0	5.9	9.2	16.4	18.3	9.9

NOTES:

1. All coils have same end supply and return connections, except opposite end steam and direct expansion (see Note 10).
2. Opposite hand steam coil return lines are the same dimension as same hand but are located on side opposite the supply.
3. Steam coils have a factory-installed vacuum breaker for pressure equalization, which must be field terminated downstream from the steam trap.
4. Steam/hot water connections may be same end as cooling coil connections, but they are recommended to be opposite end to facilitate piping. (Must be opposite end when ordering factory valve packages.)
5. Cooling condensate connection is shipped same end as cooling coil connections, but is field reversible.
6. Electric heating coil power connections are right end only.
7. See tables on page 76 for limitations with coil combinations.
8. Water coil connections are $7/8$ in. OD and terminate 9 in. from the end of the unit.
9. Steam coils supply is $1\frac{1}{8}$ in. OD condensate return line is $7/8$ in. OD and terminate 9 in. from the end of the unit.
10. Direct expansion coils have female sweat connections. Interconnecting tube by others. Liquid lines are $3/8$ in. OD and suction lines are $7/8$ in. OD.
11. Dimensions based on Design "F" units.

Base unit dimensions (cont)



COIL CONNECTIONS AND DIMENSIONS (cont) HORIZONTAL — REHEAT HEATING/COOLING

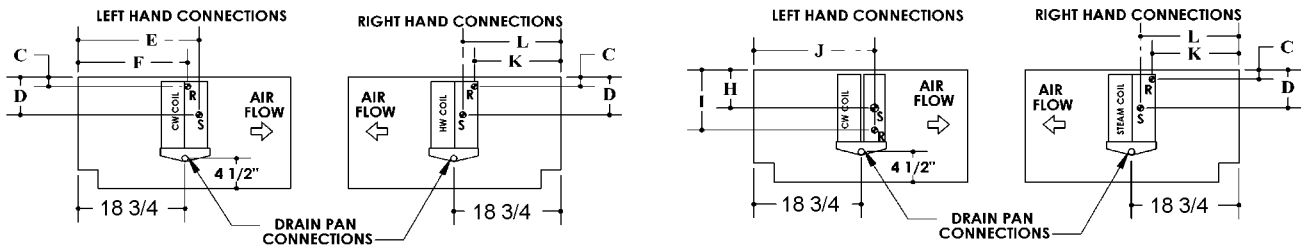

CW/HW 4-pipe

CW/Steam 4-pipe

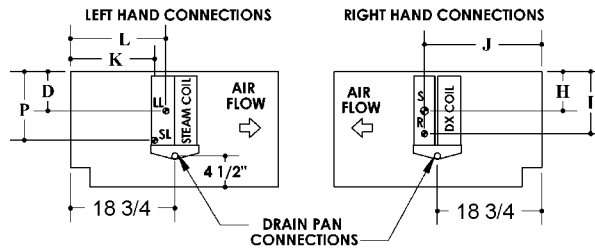

DX/Steam 4-pipe

DIMENSIONS (in.)									
C	D	E	F	H	I	J	K	L	P
1.4	5.7	21.4	20.5	5.9	9.2	20.4	16.4	18.3	9.9

- LEGEND**
- CW** — Chilled Water
 - DX** — Direct Expansion
 - HW** — Hot Water
 - LL** — Liquid Line
 - SL** — Suction Line

Accessory dimensions



END PANEL OPTIONS

16⁵/₈-in. END PANELS

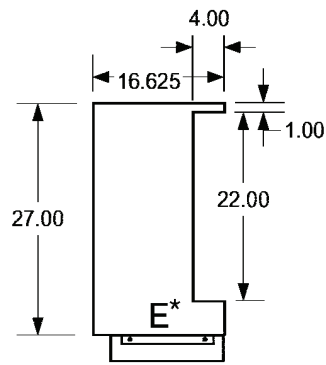
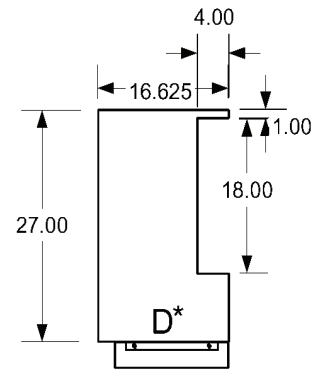
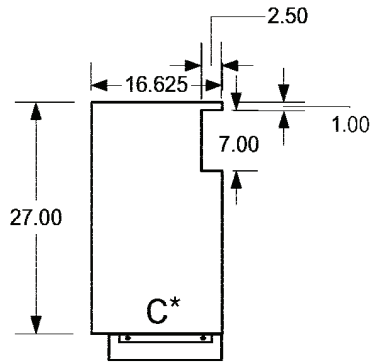
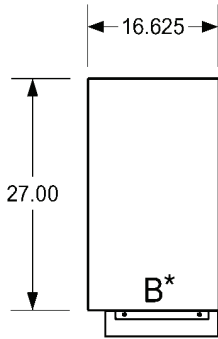

21⁷/₈-in. END PANELS

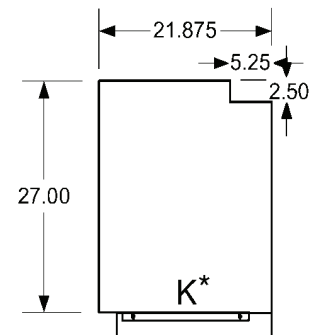
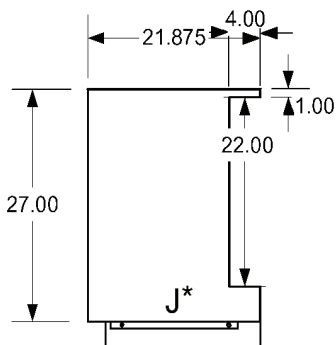
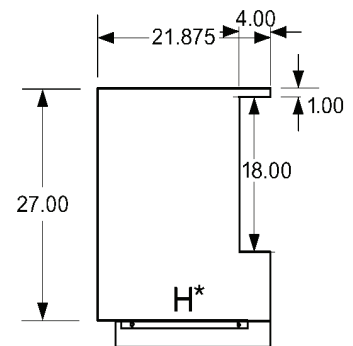
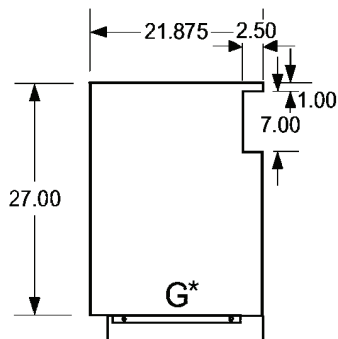
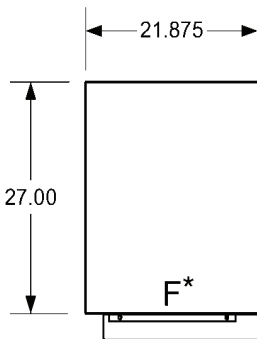

*Indicates letter used for digit 9 in model number nomenclature.

Accessory dimensions (cont)



VERTICAL UNIT VENTILATOR INLET AIR ARRANGEMENTS

16⁵/₈-in. DEEP UNITS

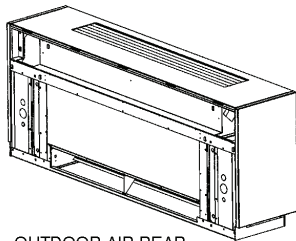

OUTDOOR AIR REAR
OPEN PIPE TUNNEL
(A,L)*

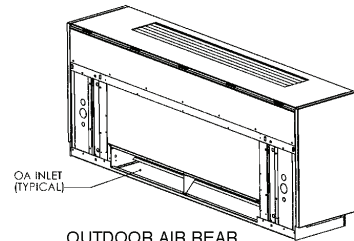

OA INLET
(TYPICAL)

OUTDOOR AIR REAR
CLOSED PIPE TUNNEL
(B,M)*

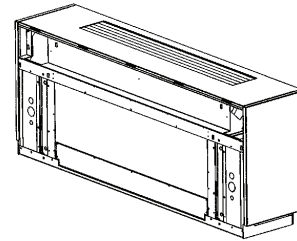

OUTDOOR AIR BOTTOM
OR RECIRC. ONLY
(C,D,N,O)*

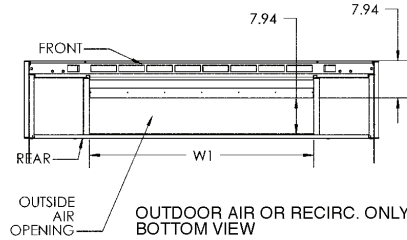

21⁷/₈-in. DEEP UNITS

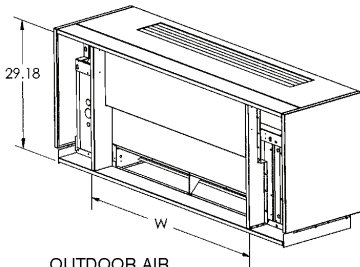

OUTDOOR AIR
FULL ADAPTER BACK
(F,R)*

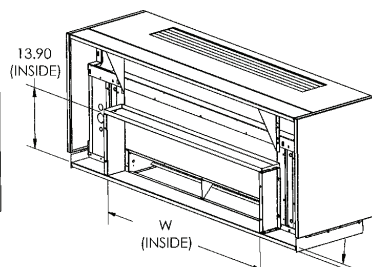

OUTDOOR AIR REAR
PIPE PASSAGE ADAPTER BACK
(E)*

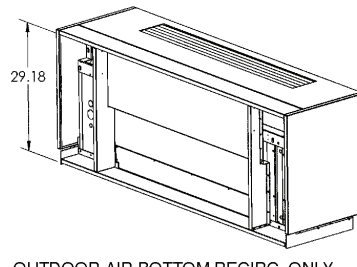

OUTDOOR AIR BOTTOM RECIRC. ONLY
FULL ADAPTER BACK
(H,I,T,U)*

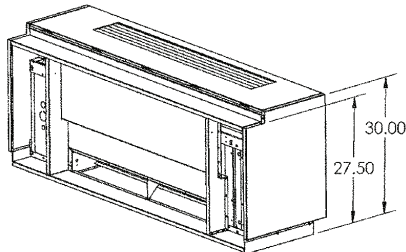

OUTDOOR AIR REAR
2.5 IN. STEP DOWN
FULL ADAPTER BACK
(K,Y)*

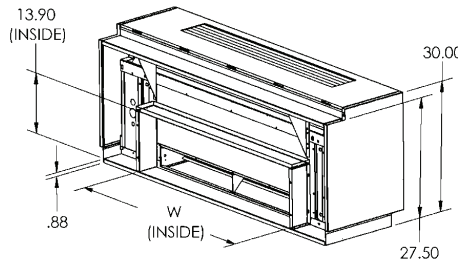

OUTDOOR AIR REAR
2.5 IN. STEP DOWN
PIPE PASSAGE ADAPTER BACK
(J,W)*

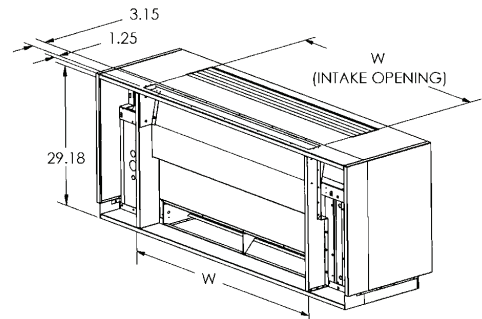

OUTDOOR AIR REAR/TOP WINDOW INTAKE
FULL ADAPTER BACK
(G)*

40UV UNIT	"W" (in.)
050	26
075	38
100	50
125	62
150	74

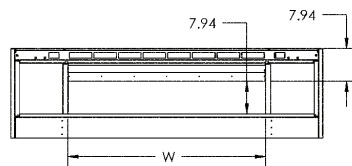

OUTDOOR AIR BOTTOM OR RECIRC. ONLY
FULL ADAPTER BACK
BOTTOM VIEW

*Indicates letter used for digit 10 in vertical unit model number nomenclature.
NOTE: Cabinet draft stop P and S are not shown.

HORIZONTAL UNIT VENTILATOR INLET AIR/DISCHARGE AIR ARRANGEMENTS

Bar Stock
Discharge Grille -
Front Discharge
A & B*
40UHF2 thru 5
MODELS ONLY

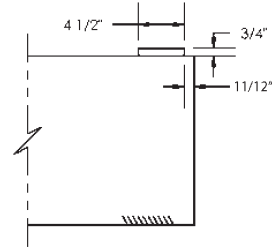
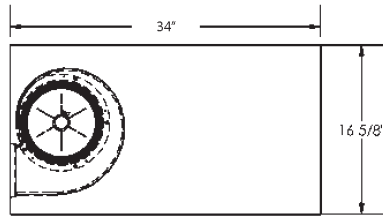

Bottom Return Grille -
Top Outdoor Air
A†

Duct Collar -
Front Discharge
C*
40UHF2 thru 5
MODELS ONLY

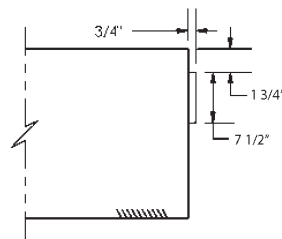
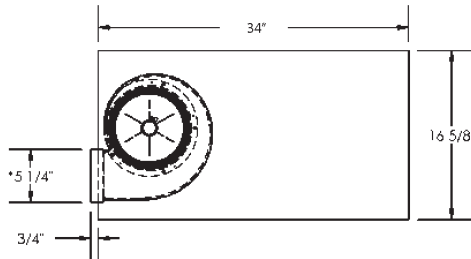

Bottom Return Grille -
Rear Outdoor Air
B†

Duct Collar -
Front Discharge
Plenum
D*

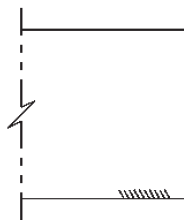
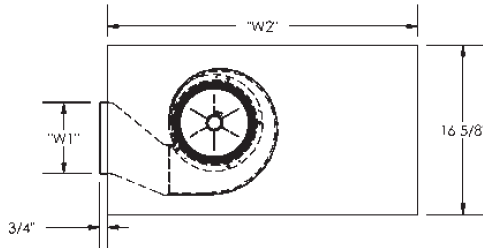

Bottom Return Grille -
No Outdoor Air
C†

Double Deflection Grille -
Front Discharge Plenum -
E*

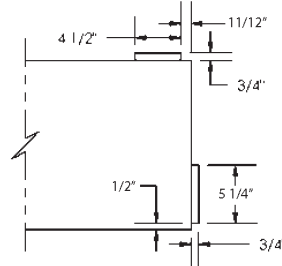
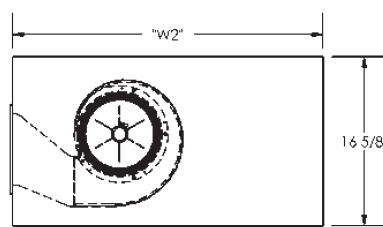

Rear Return Air -
Top Outdoor Air
D†

Double Deflection Grille -
Down Discharge Plenum -
F*

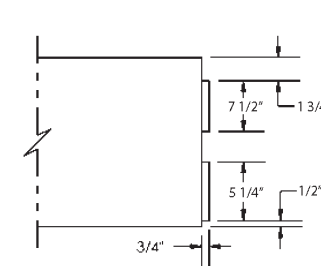
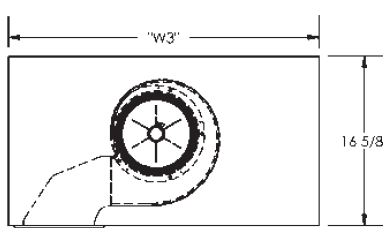

Rear Return Air -
Rear Outdoor Air
E†

40UHF	CFM	W1 (in.)	W2 (in.)	W3 (in.)
075	750	7 x 36	39.5	43.5
100	1000	7 x 48	39.5	43.5
125	1250	7 x 60	39.5	43.5
150	1500	7 x 72	39.5	43.5
200	2000	10 x 72	43.5	47.5

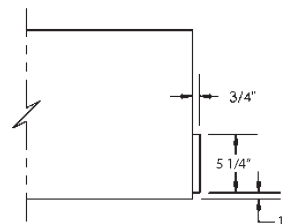

Rear Return Air -
No Outdoor Air
F†

* Indicates letter used for digit 11 in model number nomenclature.
† Indicates letter used for digit 10 in horizontal unit model number nomenclature.

Accessory dimensions (cont)



40UV,UH UNIT VENTILATOR BAROMETRIC PRESSURE RELIEF DAMPER

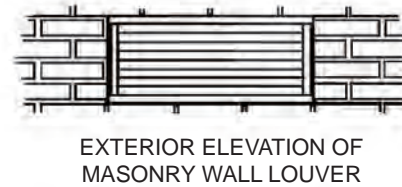
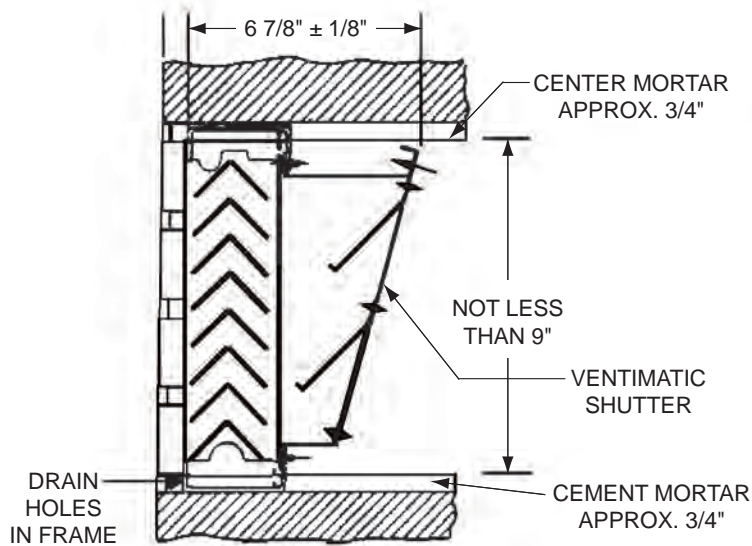
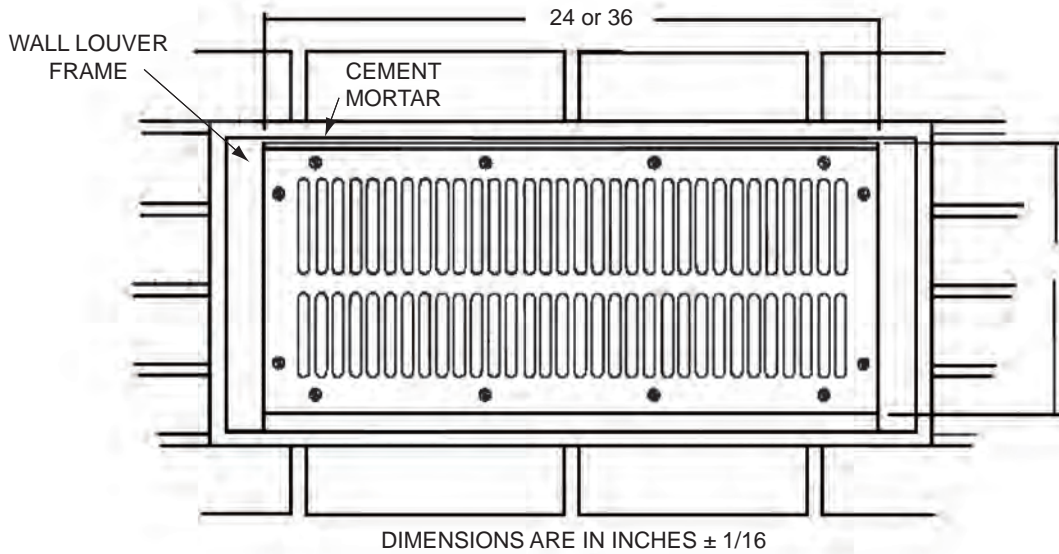

UNIT 40UV,UH	DIMENSIONS (In.)	COMMENTS
050	24	1 relief damper
075	36	1 relief damper
100	48	Two 24 inch relief dampers
125	60	One 24 inch and one 36 inch relief damper
150,200	72	Two 36 inch relief dampers

**40UV,UH UNIT VENTILATOR
VERTICAL BLADE
LOUVER WITHOUT FLANGE
SIZES 050-200**

DIAMOND PATTERN
EXPANDED ALUMINUM
BIRD SCREEN (WBS-1)

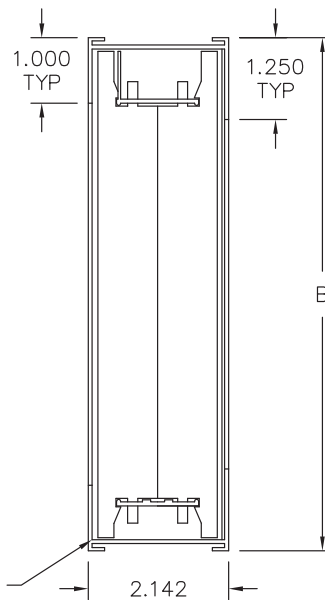
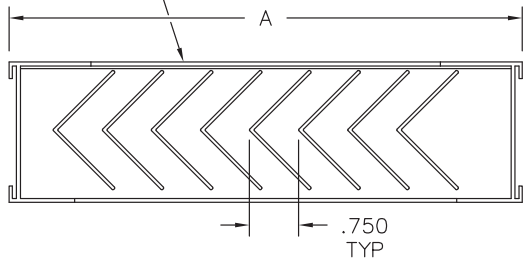

WEEP HOLES
AS REQUIRED
(FACE ONLY)

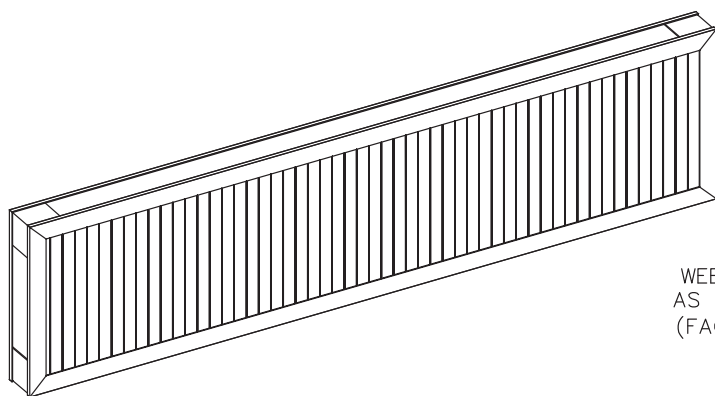

NOTE: All dimensions are in inches.

UNIT 40UV,UH	DIMENSIONS (in.)		WALL OPENING DIMENSIONS (in.)	
	A	B	A	B
050	24	10 ³ / ₈	24 ¹ / ₂	10 ⁵ / ₈
075	36	10 ³ / ₈	36 ¹ / ₂	10 ⁵ / ₈
100	48	10 ³ / ₈	48 ¹ / ₂	10 ⁵ / ₈
125	60	10 ³ / ₈	60 ¹ / ₂	10 ⁵ / ₈
150,200	72	10 ³ / ₈	72 ¹ / ₂	10 ⁵ / ₈

Accessory dimensions (cont)



40UV,UH UNIT VENTILATOR VERTICAL BLADE LOUVER WITH FLANGE SIZES 050-200

DIAMOND PATTERN
EXPANDED ALUMINUM
BIRD SCREEN (WBS-1)

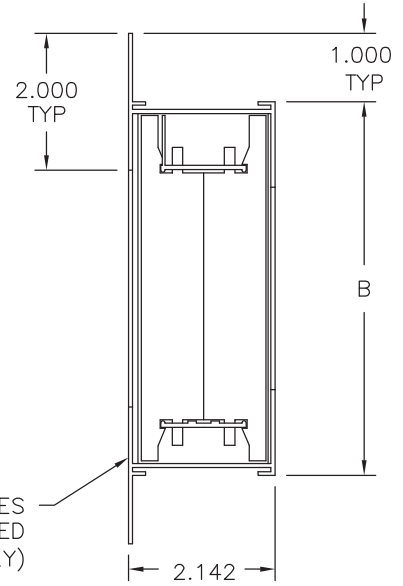
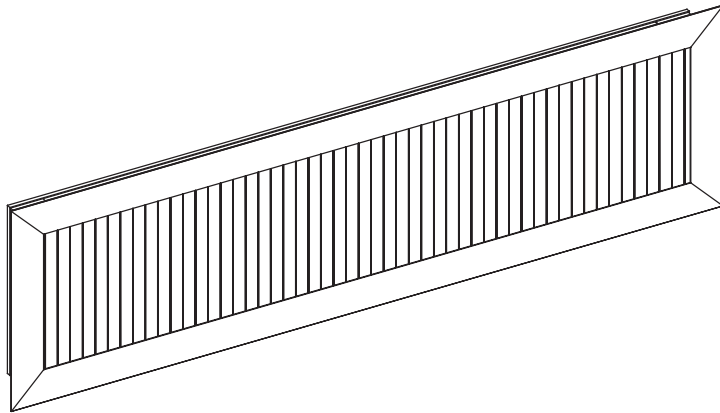
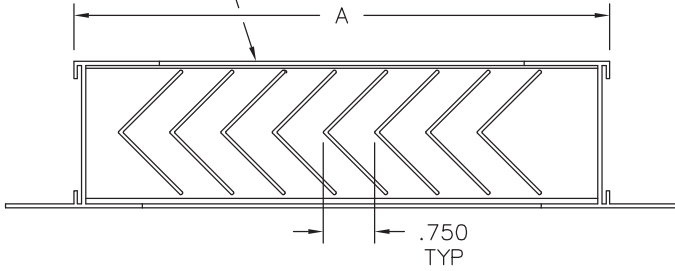

NOTE: All dimensions are in inches.

UNIT 40UV,UH	DIMENSIONS (in.)		WALL OPENING DIMENSIONS (in.)	
	A	B	A	B
050	24	10 ³ / ₈	24 ¹ / ₂	10 ⁵ / ₈
075	36	10 ³ / ₈	36 ¹ / ₂	10 ⁵ / ₈
100	48	10 ³ / ₈	48 ¹ / ₂	10 ⁵ / ₈
125	60	10 ³ / ₈	60 ¹ / ₂	10 ⁵ / ₈
150,200	72	10 ³ / ₈	72 ¹ / ₂	10 ⁵ / ₈

**40UV,UH UNIT VENTILATOR
HORIZONTAL BLADE
LOUVER WITHOUT FLANGE
SIZES 050-200**

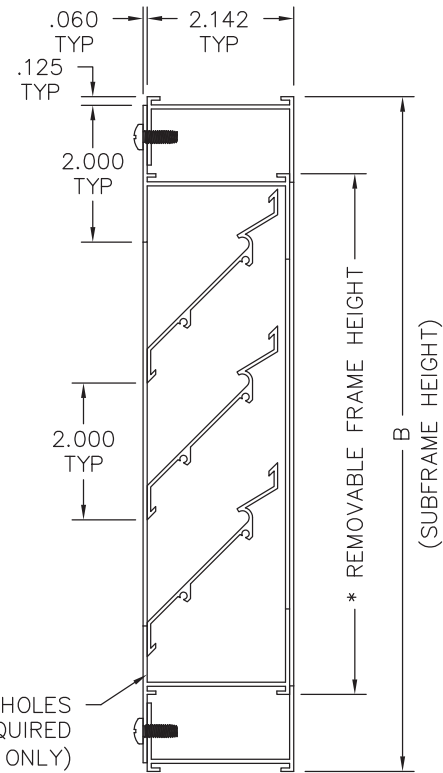
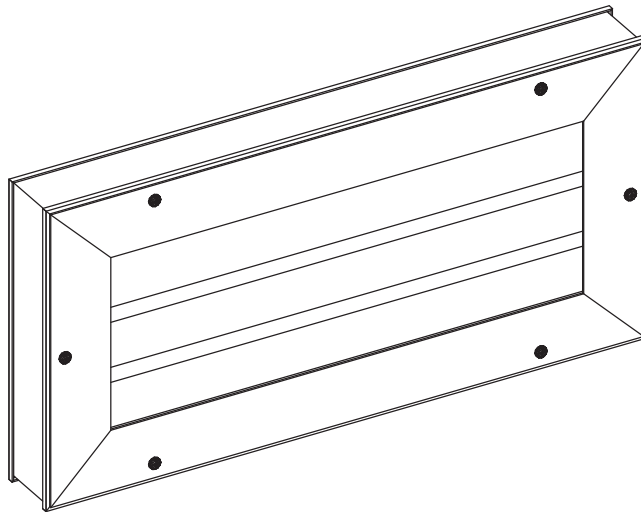
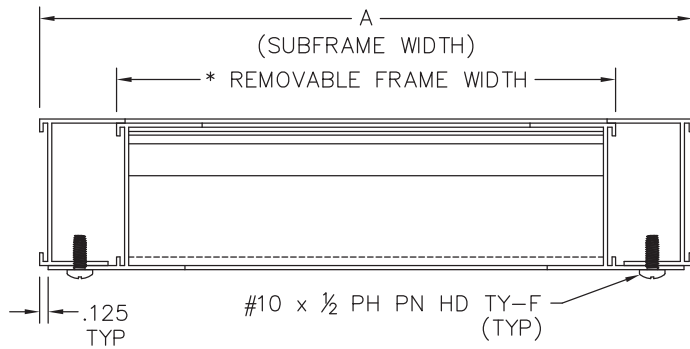

WEEP HOLES
AS REQUIRED
(FACE ONLY)

UNIT 40UV,UH	DIMENSIONS (in.)		RECOMMENDED WALL OPENING (in.)	
	A	B	A	B
050	24	10 ³ / ₈	24 ¹ / ₂	10 ⁵ / ₈
075	36	10 ³ / ₈	36 ¹ / ₂	10 ⁵ / ₈
100	48	10 ³ / ₈	48 ¹ / ₂	10 ⁵ / ₈
125	60	10 ³ / ₈	60 ¹ / ₂	10 ⁵ / ₈
150,200	72	10 ³ / ₈	72 ¹ / ₂	10 ⁵ / ₈

NOTE: All dimensions are in inches.

Accessory dimensions (cont)



40UV,UH UNIT VENTILATOR HORIZONTAL BLADE LOUVER WITH FLANGE SIZES 050-200

DIAMOND PATTERN
EXPANDED ALUMINUM
BIRD SCREEN (WBS-1)

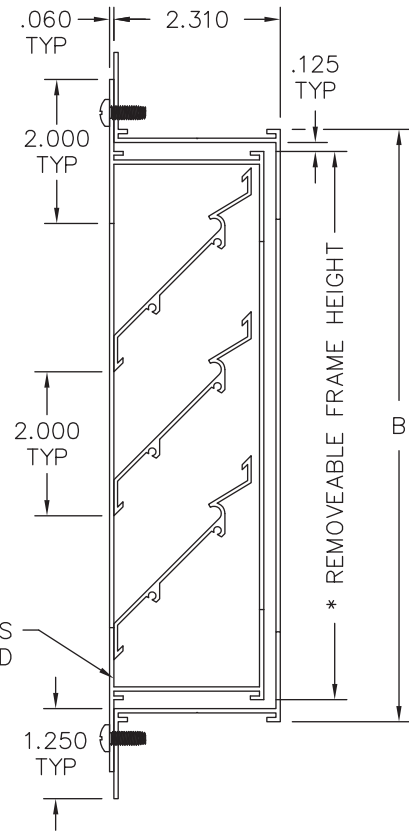
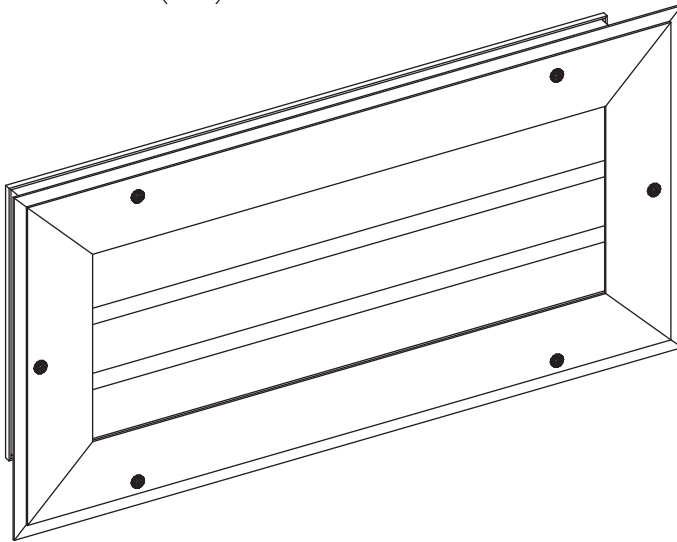
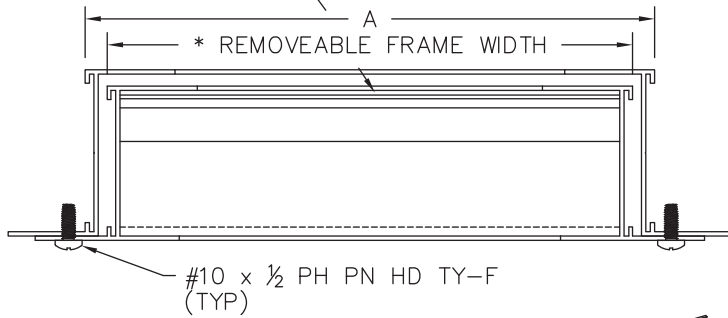

UNIT 40UV,UH	DIMENSIONS (in.)		WALL OPENING DIMENSIONS (in.)	
	A	B	A	B
050	24	10 ³ / ₈	24 ¹ / ₂	10 ⁵ / ₈
075	36	10 ³ / ₈	36 ¹ / ₂	10 ⁵ / ₈
100	48	10 ³ / ₈	48 ¹ / ₂	10 ⁵ / ₈
125	60	10 ³ / ₈	60 ¹ / ₂	10 ⁵ / ₈
150,200	72	10 ³ / ₈	72 ¹ / ₂	10 ⁵ / ₈

NOTE: All dimensions are in inches.

**40UV,UH UNIT VENTILATOR
VERTICAL BLADE LOUVER WITH LATTICE GRILLE WITHOUT FLANGE
SIZES 050-200**

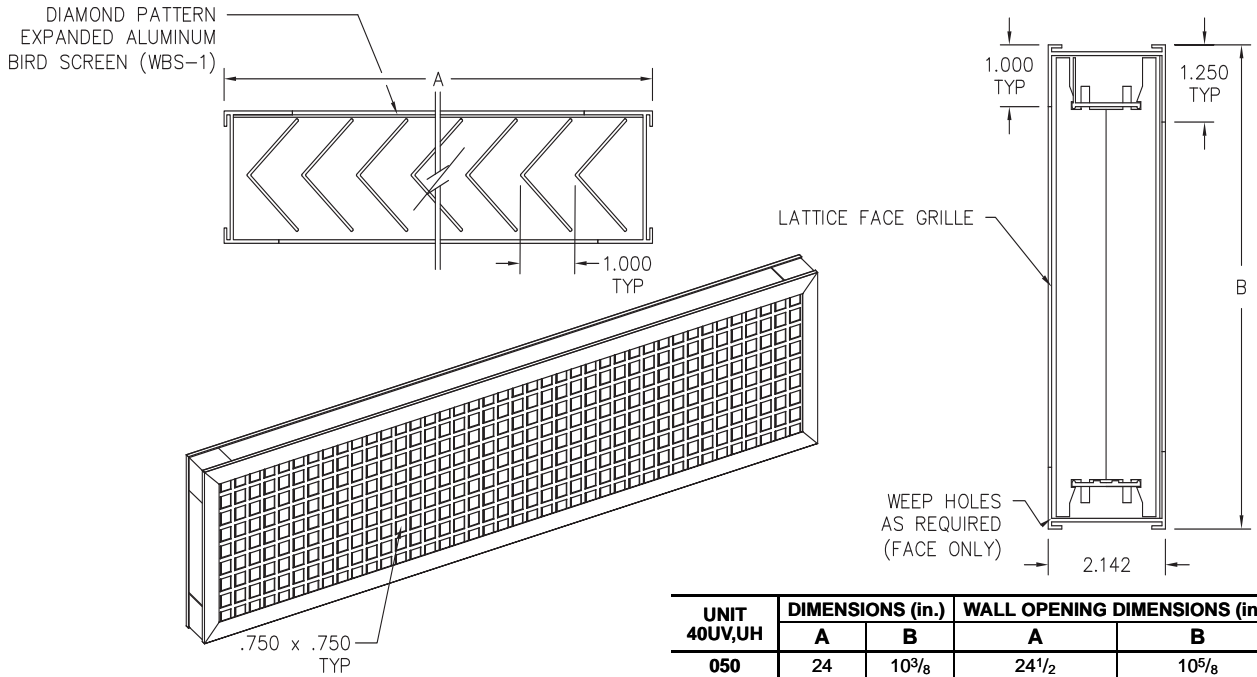

UNIT 40UV,UH	DIMENSIONS (in.)		WALL OPENING DIMENSIONS (in.)	
	A	B	A	B
050	24	10 ³ / ₈	24 ¹ / ₂	10 ⁵ / ₈
075	36	10 ³ / ₈	36 ¹ / ₂	10 ⁵ / ₈
100	48	10 ³ / ₈	48 ¹ / ₂	10 ⁵ / ₈
125	60	10 ³ / ₈	60 ¹ / ₂	10 ⁵ / ₈
150,200	72	10 ³ / ₈	72 ¹ / ₂	10 ⁵ / ₈

NOTE: All dimensions are in inches.

**40UV,UH UNIT VENTILATOR
VERTICAL BLADE LOUVER WITH LATTICE GRILLE WITH FLANGE
SIZES 050-200**

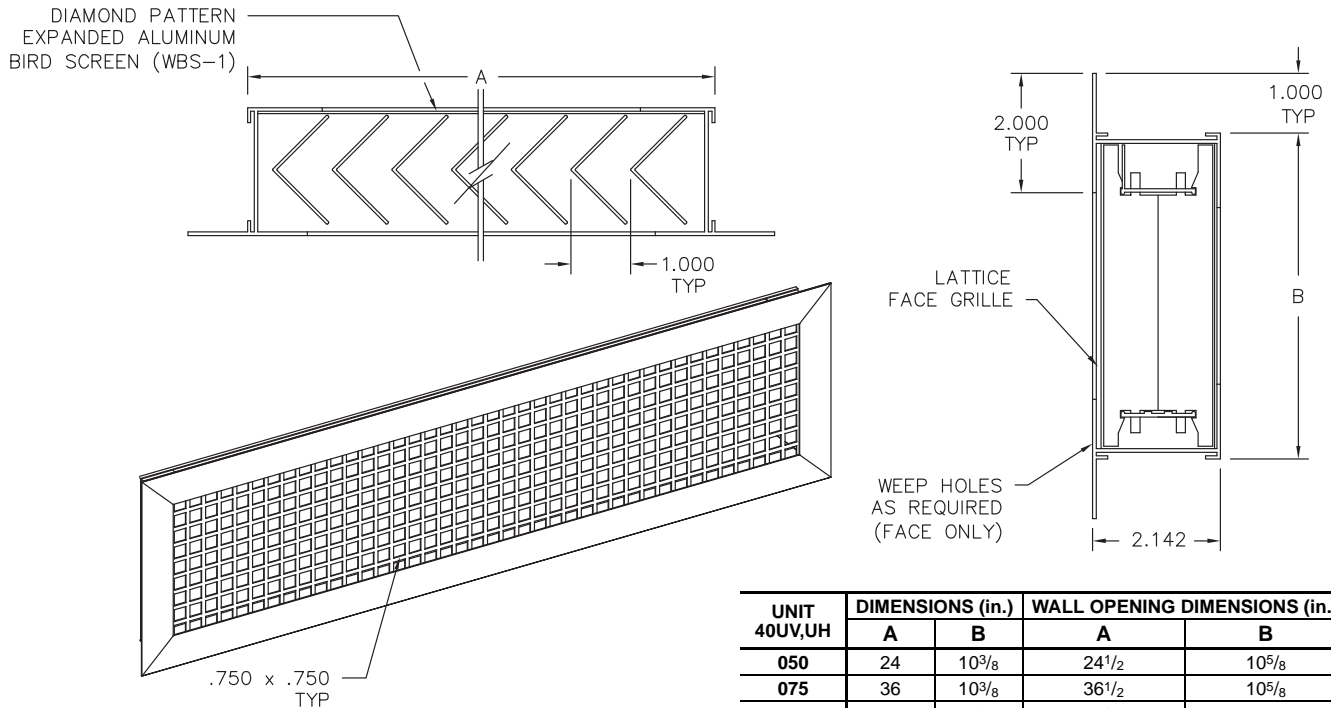

UNIT 40UV,UH	DIMENSIONS (in.)		WALL OPENING DIMENSIONS (in.)	
	A	B	A	B
050	24	10 ³ / ₈	24 ¹ / ₂	10 ⁵ / ₈
075	36	10 ³ / ₈	36 ¹ / ₂	10 ⁵ / ₈
100	48	10 ³ / ₈	48 ¹ / ₂	10 ⁵ / ₈
125	60	10 ³ / ₈	60 ¹ / ₂	10 ⁵ / ₈
150,200	72	10 ³ / ₈	72 ¹ / ₂	10 ⁵ / ₈

NOTE: All dimensions are in inches.

Accessory dimensions (cont)

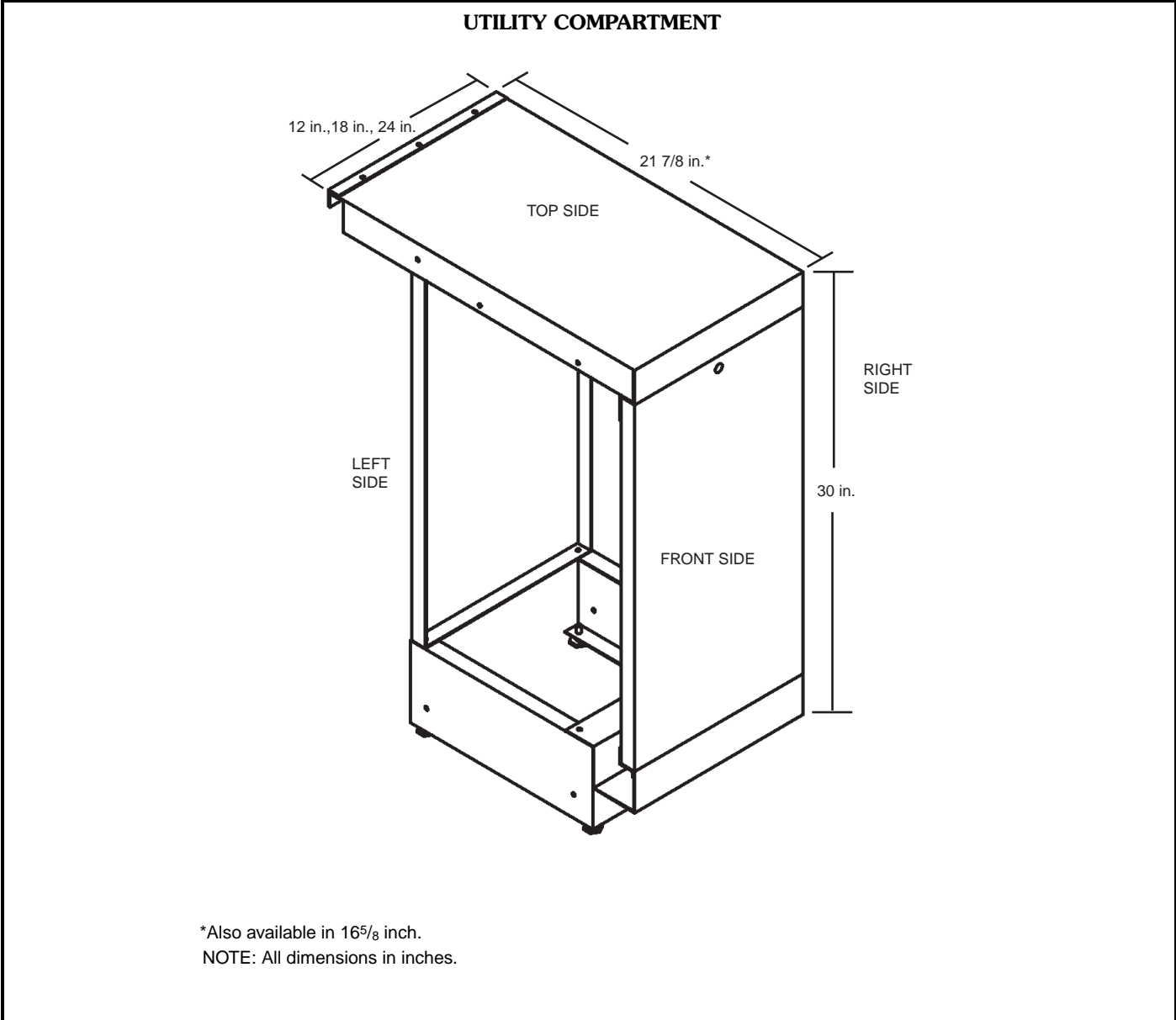

**40UV UNIT VENTILATOR
POWERED EXHAUSTER
16⁵/₈-in. DEEP UNIT
2 FAN UNIT — 500 CFM
3 FAN UNIT — 750 CFM**

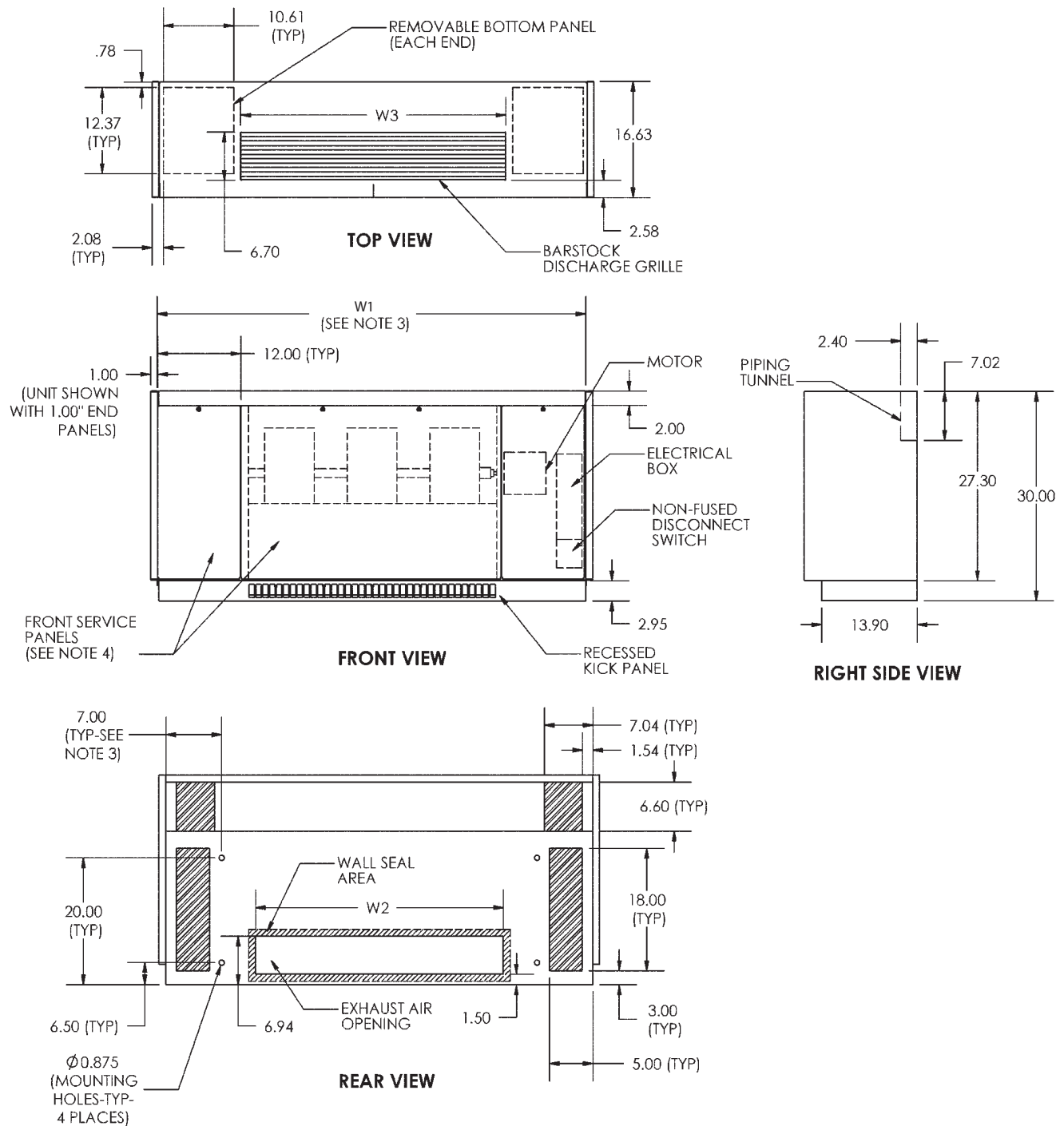

NOTES:

1. All dimensions in inches.
2. Dimension does not include end panels.
3. Three front panels provided for service access.
4. Motor and electrical power input box on right of unit. Box includes fan speed switch, and non-fused disconnect switch.

NO. OF FANS	CFM	W1	W2	W3	APPROXIMATE INSTALLED WEIGHT (lb)
2	500	50	26	26.5	245
3	750	62	38	38.5	315

Accessory dimensions (cont)



40UV UNIT VENTILATOR POWERED EXHAUSTER 21⁷/₈-in. DEEP UNIT

DIRECT DRIVE FAN MOTOR
2 FAN UNIT — 500 CFM
3 FAN UNIT — 750 CFM

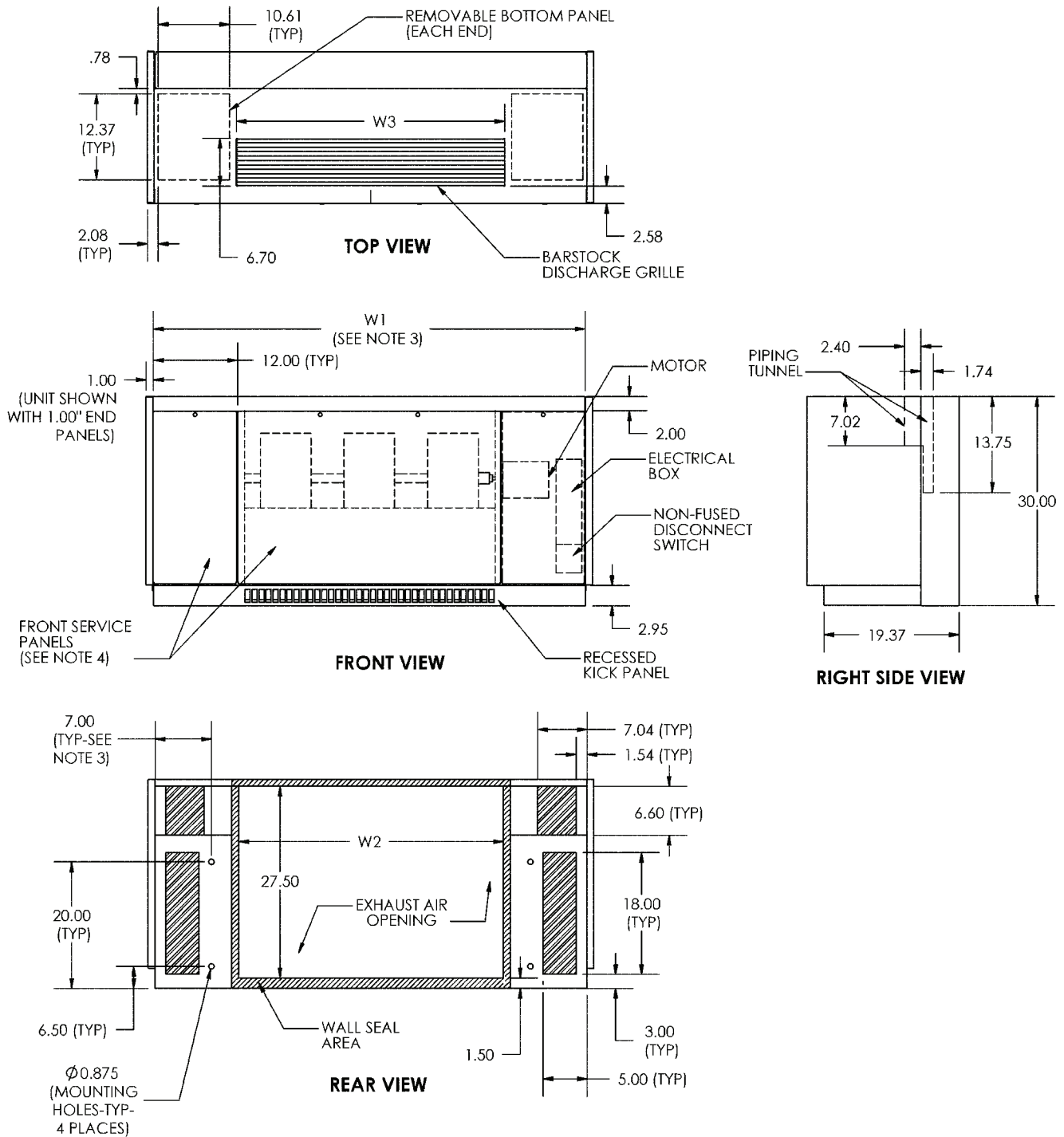

NOTES:

1. All dimensions in inches.
2. Dimension does not include end panels.
3. Three front panels provided for service access.
4. Motor and electrical power input box on right of unit. Box includes fan speed switch, and non-fused disconnect switch.

NO. OF FANS	CFM	W1	W2	W3	APPROXIMATE INSTALLED WEIGHT (lb)
2	500	50	26	26.5	255
3	750	62	38	38.5	330

POWERED EXHAUSTER APPLICATIONS

**21⁷/₈ IN. POWERED EXHAUSTER
HIGH DISCHARGE**

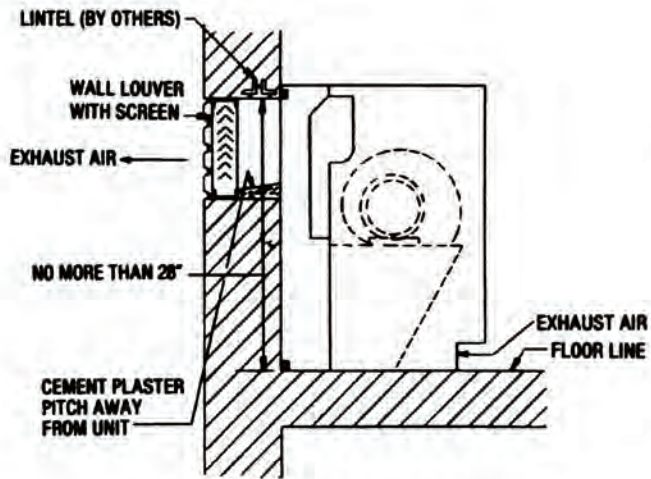

**28 IN. POWERED EXHAUSTER
TYPICAL INSTALLATION**

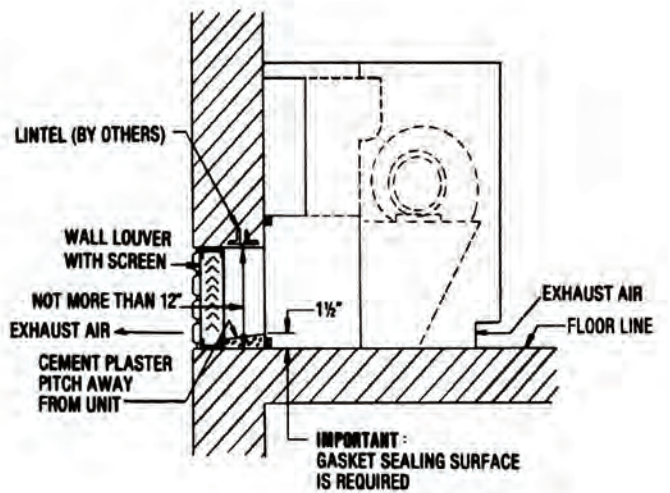

21⁷/₈ IN. TYPICAL INSTALLATION

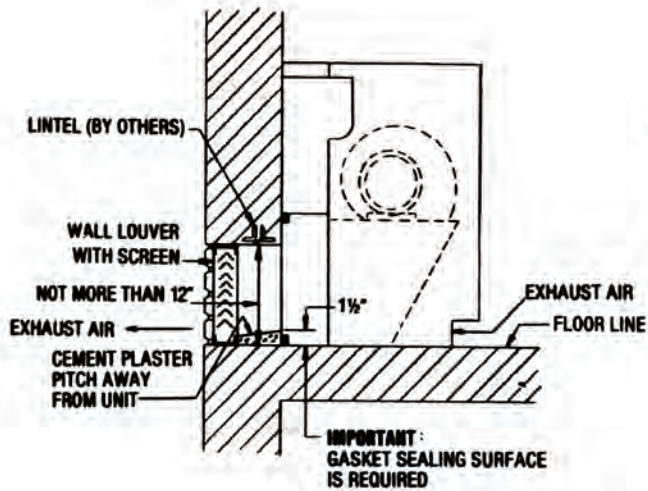

16⁵/₈ IN. TYPICAL INSTALLATION

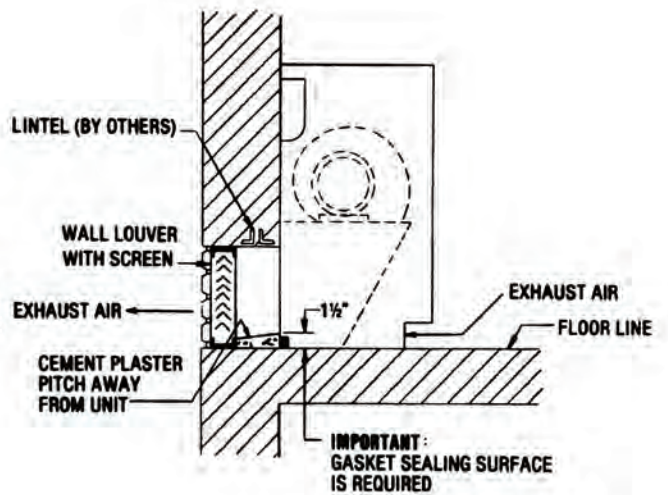

Accessory dimensions (cont)



STORAGE CABINET DETAILS

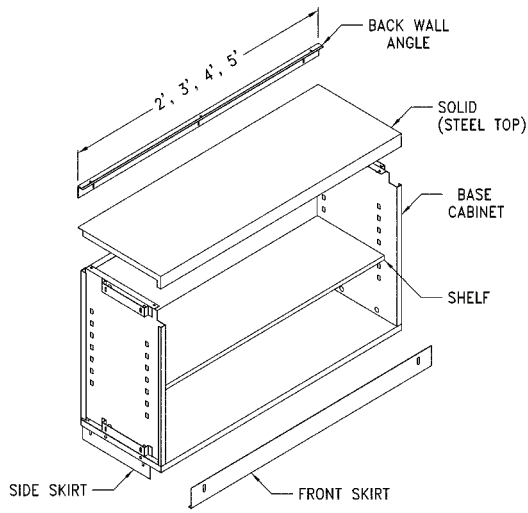

Solid Top (Typical)

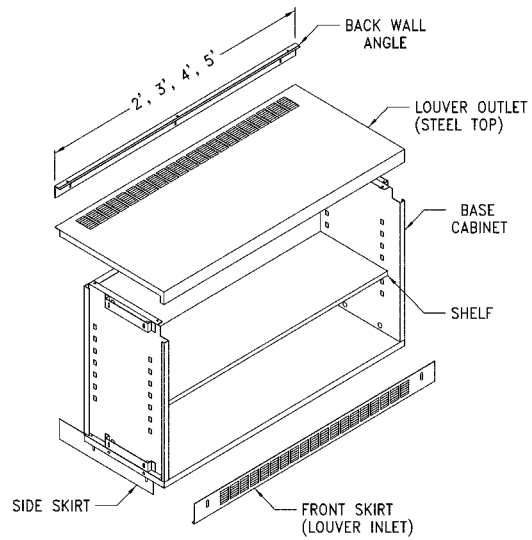

Louvered Grille (Typical)

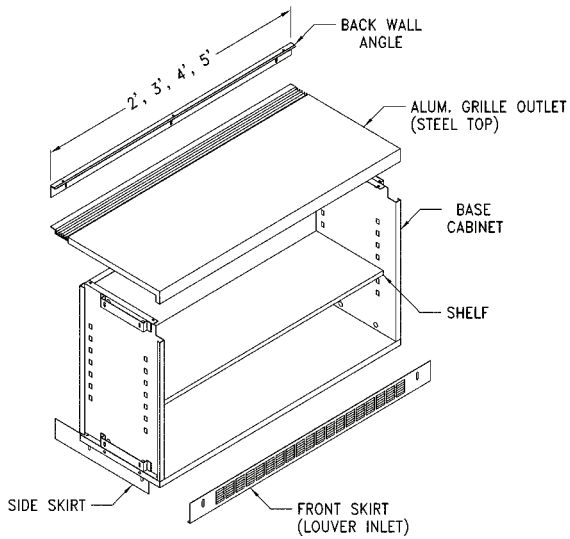

Extruded Aluminum Grille (Typical)

16⁵/₈-in. DEEP STORAGE CABINET DETAILS SIDE VIEWS WITH BACK OPTION EXAMPLES

SC161* — Standard Storage Cabinet

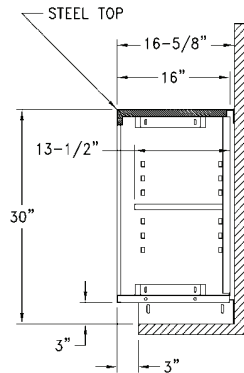

SC166* — Standard Storage Cabinet with Louvered Inlet and Aluminum Extrusion Outlet

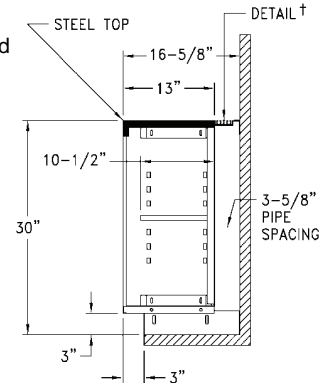

SC162* — Standard Storage Cabinet with Pipe Chase

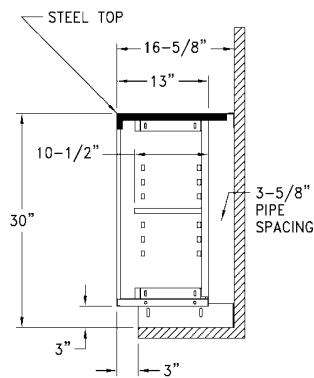

SC167* — Standard Storage Cabinet with Shallow Shelf with Pipe Chase

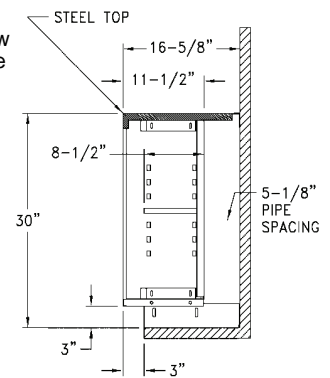

SC164* — Standard Storage Cabinet with Louvered Inlet and Outlet

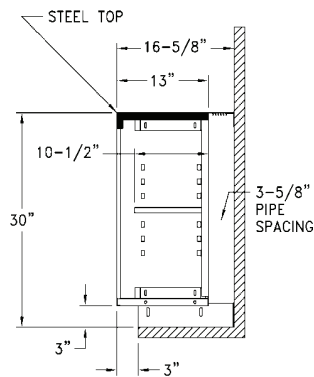

SC168* — Standard Storage Cabinet with Shallow Shelf with Louvered Inlet and Outlet

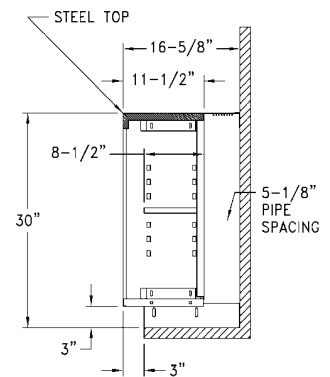

SC165* — Standard Storage Cabinet with Aluminum Extrusion Draft Stop Inlet

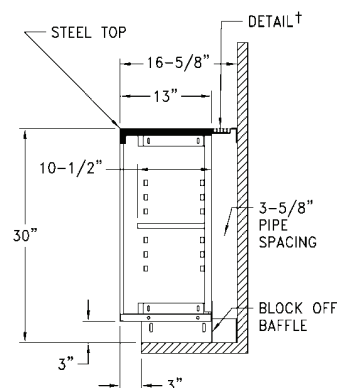

SC169* — Standard Storage Cabinet with Shallow Shelf with Louvered Inlet and Aluminum Extension Outlet

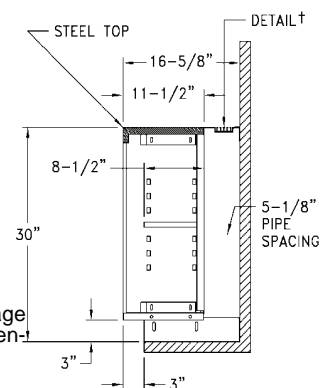

*Refers to digits 1-5 in Storage Cabinet Accessory Model Nomenclature (see page 6).
†See details on page 40.

NOTE: All dimensions in inches.

Accessory dimensions (cont)



21⁷/₈-in. DEEP STORAGE CABINET DETAILS SIDE VIEWS WITH BACK OPTION EXAMPLES

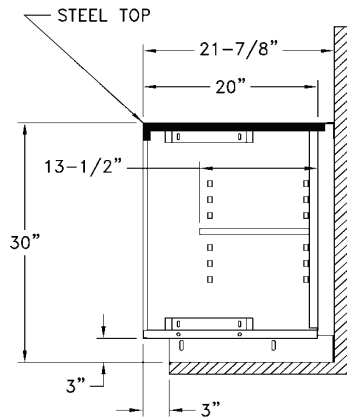

SC211* — Standard Storage Cabinet

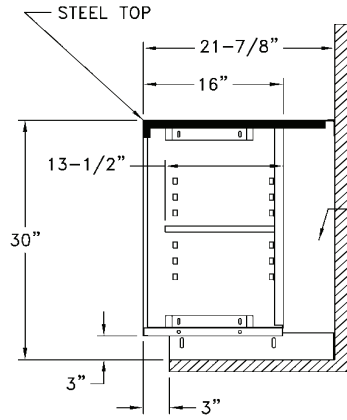

SC212* — Standard Storage Cabinet with Pipe Chase

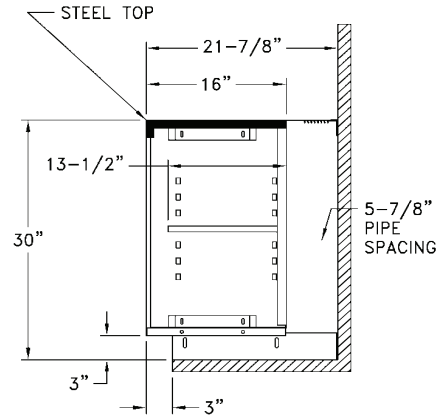

SC214* — Standard Storage Cabinet with Louvered Inlet and Outlet

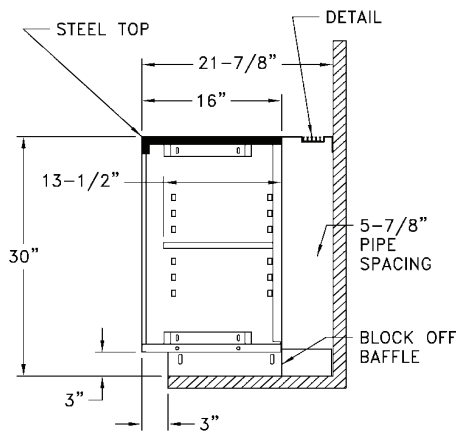

SC215* — Standard Storage Cabinet with Aluminum Extrusion Draft Stop Inlet

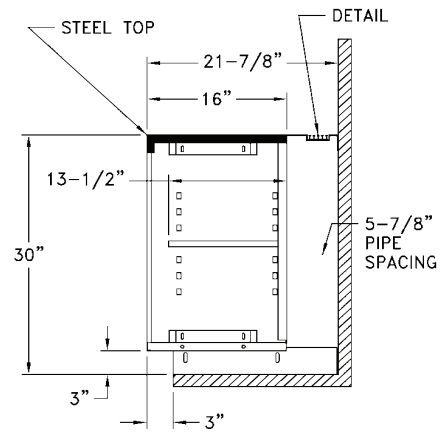

SC216* — Standard Storage Cabinet with Louvered Inlet and Aluminum Extrusion Outlet

*Refers to digits 1-5 in Storage Cabinet Accessory Model Nomenclature (see page 6).
NOTE: All dimensions in inches.

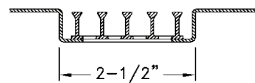

Detail - Radiation Grille

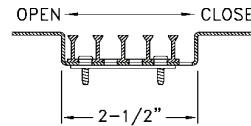

Detail - Draft Elimination Grille

STORAGE CABINET DOORS AND TOTE TRAYS

SLIDING DOORS

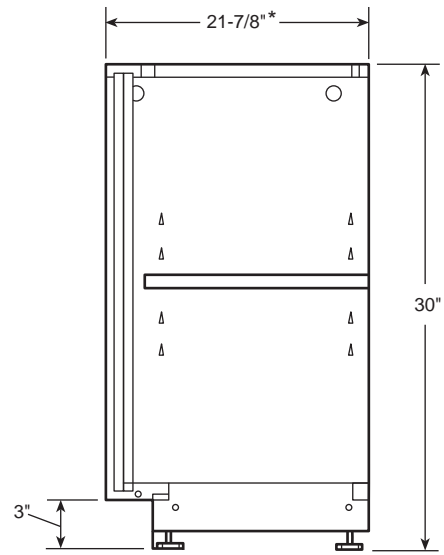
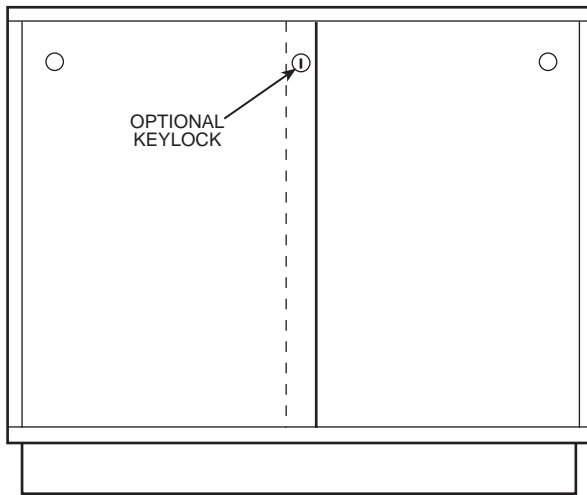

TOTE TRAYS

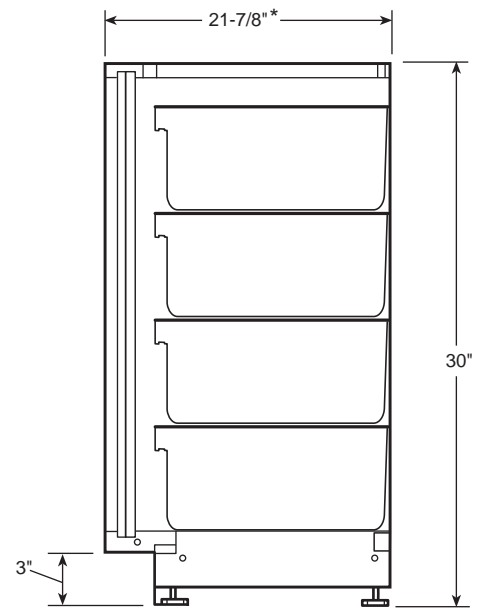
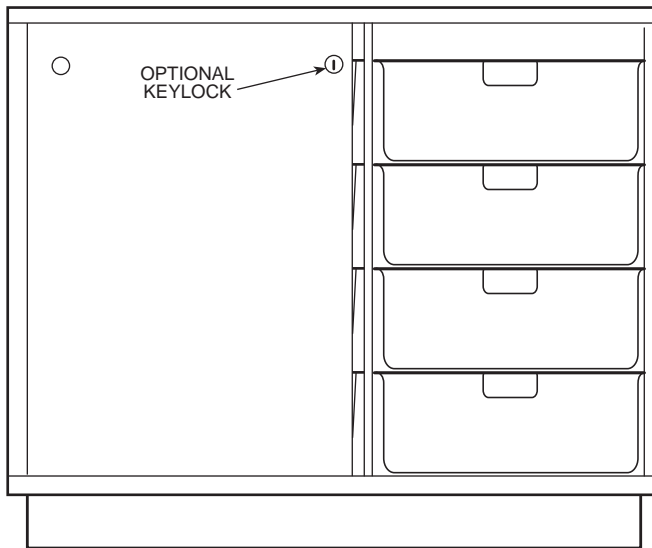

*Also available in $16\text{ }^5/8\text{''}$ inch.

Accessory dimensions (cont)



FILLER SECTIONS: TOP, END AND CORNER PANELS

TOP AND END FILLER PANELS

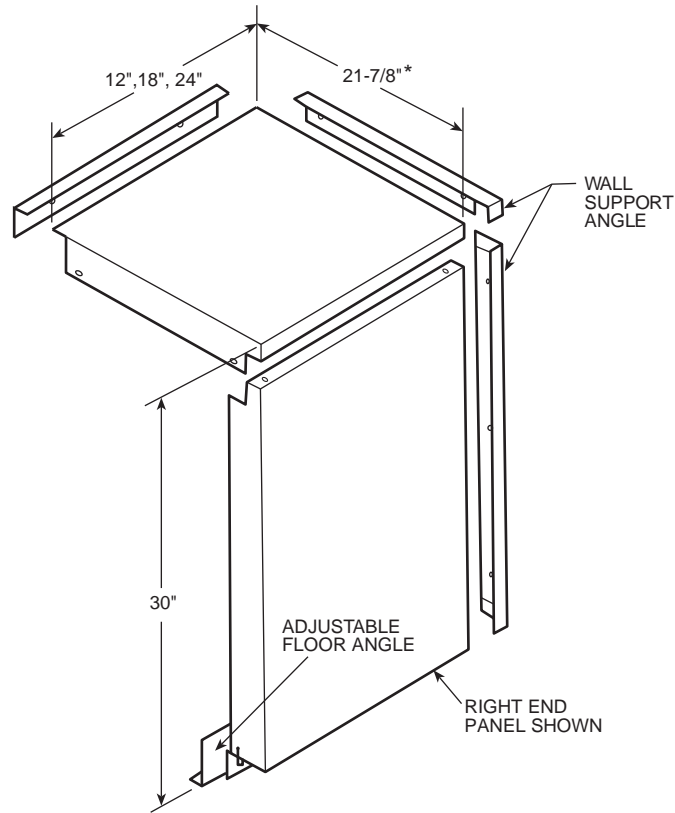

CORNER FILLER PANEL

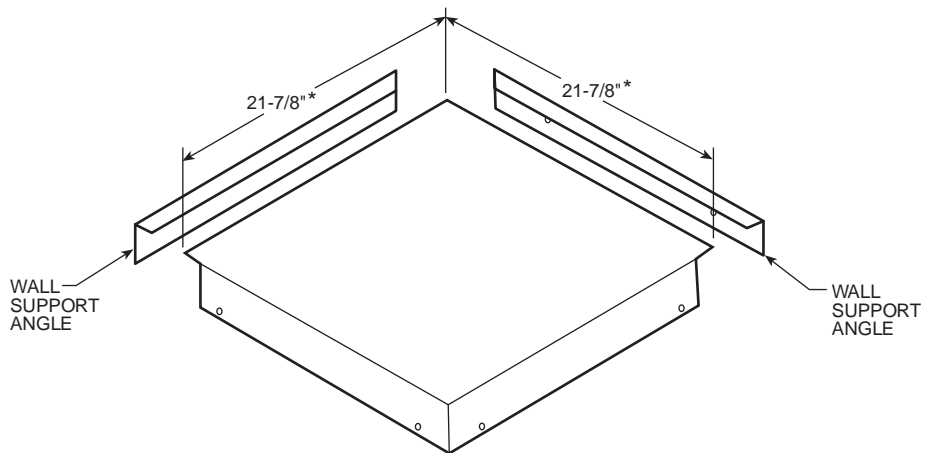

*Also available in 16⁵/₈ inch.

**DRAFT STOP ENCLOSURES: LOUVERED AND GRILLED INLETS
(2-6 FT STANDARD LENGTHS)**

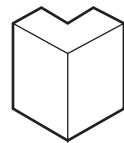
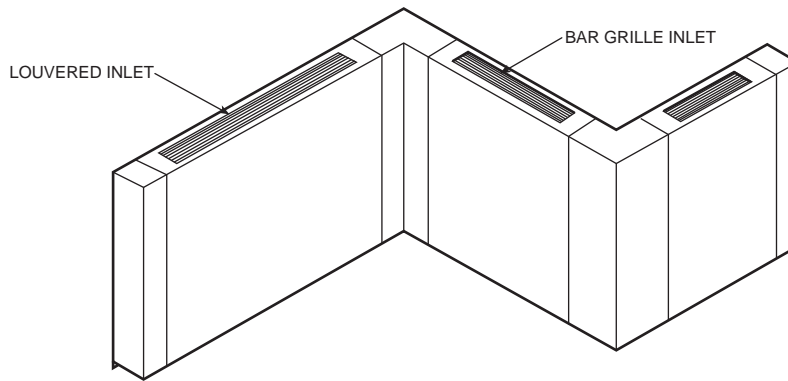

OUTSIDE CORNER



INSIDE CORNER



END CAP



TRIM STRIP
3-1/2" N.
5-IN.
7-1/2" N.



SECURITY DAMPER

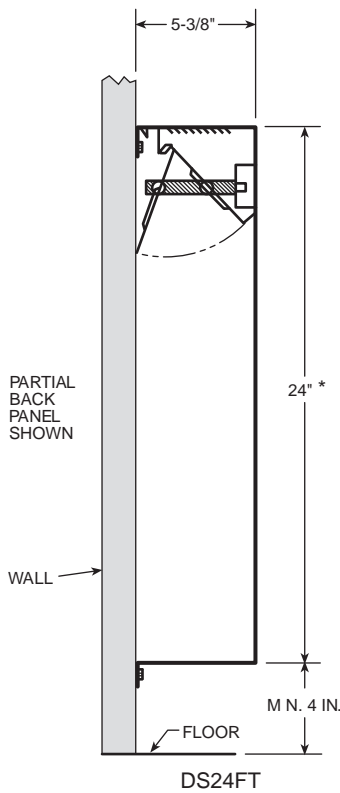

LOUVERED TOP
(includes screw security damper)

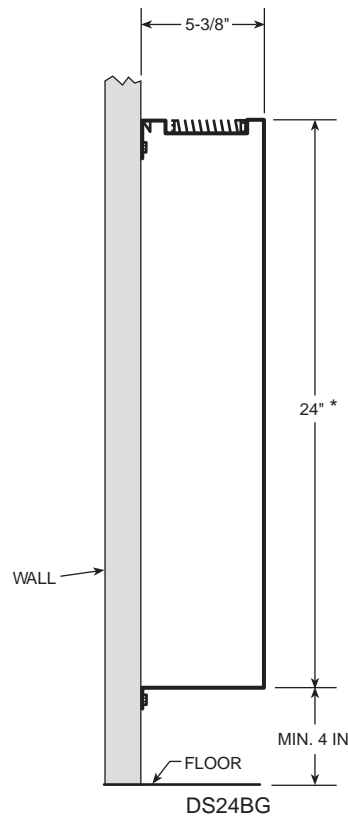

ALUMINUM BAR GRILLE
(includes slide damper)

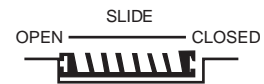

*Also available in 12 inch and 20 inch.

Accessory dimensions (cont)



PIPE ENCLOSURE WALL MOUNTS (STANDARD LENGTHS 1-8 FT)

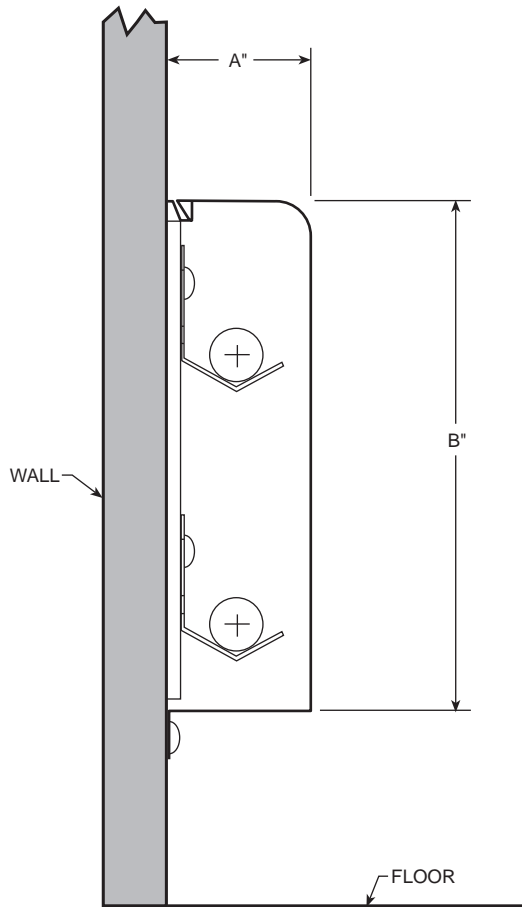

WALL MOUNTED, CLOSED BOTTOM

NOTE: Pipe hangers are field-supplied.

A	B			
4 in.	8 in.	11 in.	14 in.	20 in.
5 in.				

SINK AND BUBBLER UNIT

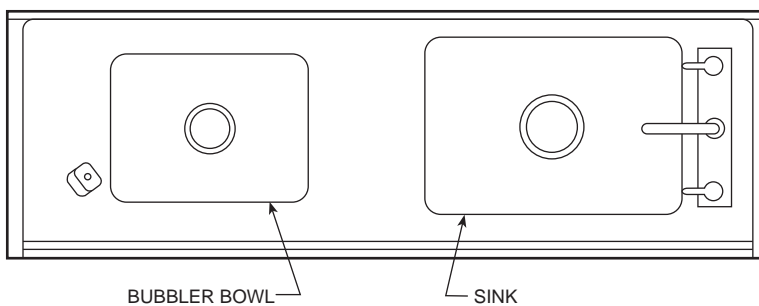

TOP

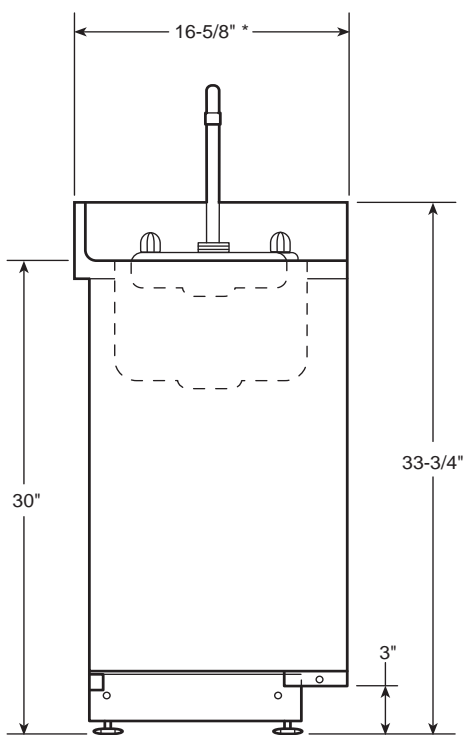

SIDE

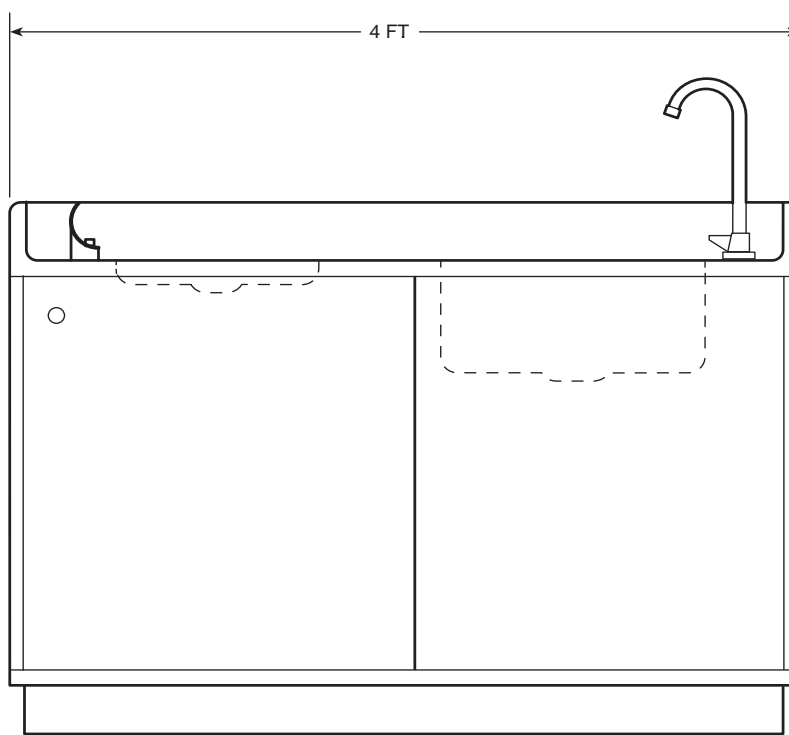

FRONT

*Also available in 21⁷/₈ inch.

NOTES:

1. Sink bowl is 16 in. x 11¹/₂ in. x 7¹/₂ in. deep.
2. Bubbler bowl is 12¹/₂ in. x 9¹/₂ in. x 1³/₄ in. deep.

Selection procedure

Use Carrier's electronic selection software to perform unit selections at a variety of actual operating conditions. Performance at typical operating conditions is shown in the following performance tables.

Performance data



40UV COOLING CAPACITY — CHILLED WATER COILS

SIZE 050 — 3 ROW

EWT (F)	GPM	PD (ft)		CFM								
				500			350			250		
				Entering Air Temperature — EDB/EWB (F)								
				85/71	80/67	75/63	85/71	80/67	75/63	85/71	80/67	75/63
42	2	1.0	TC	11.96	10.06	8.08	10.53	8.80	7.07	9.20	7.57	6.07
			SHC	7.87	7.20	6.39	6.66	6.05	5.34	5.66	5.06	4.45
			LDB	70.6	66.8	63.3	67.6	64.2	61.0	64.3	61.5	58.7
			LWB	64.3	60.9	57.7	62.4	59.2	56.3	60.3	57.5	54.8
	4	3.1	TC	14.46	12.03	9.66	12.35	10.16	8.25	10.30	8.47	6.91
			SHC	8.96	8.09	7.13	7.50	6.69	5.92	6.18	5.50	4.87
			LDB	68.6	65.2	62.0	65.4	62.5	59.5	62.4	59.9	57.2
			LWB	62.8	59.6	56.6	60.8	57.9	55.1	58.8	56.2	53.6
	6	6.2	TC	15.45	12.71	10.37	12.88	10.79	8.66	10.81	8.89	7.14
			SHC	9.42	8.42	7.47	7.75	7.00	6.12	6.44	5.71	4.98
			LDB	67.8	64.6	61.3	64.8	61.7	59.0	61.5	59.1	56.8
			LWB	62.2	59.2	56.1	60.3	57.3	54.6	58.1	55.6	53.2
8	10.2	TC	16.10	13.25	10.64	13.26	11.11	8.76	11.03	9.07	7.29	
		SHC	9.73	8.68	7.61	7.94	7.16	6.17	6.55	5.81	5.06	
		LDB	67.2	64.1	61.1	64.3	61.3	58.9	61.0	58.8	56.5	
		LWB	61.8	58.8	55.9	59.9	57.0	54.5	57.8	55.4	53.0	
45	2	1.0	TC	10.89	8.89	6.95	9.59	7.82	6.12	8.38	6.76	5.35
			SHC	7.43	6.69	5.88	6.25	5.61	4.90	5.28	4.69	4.11
			LDB	71.4	67.8	64.2	68.7	65.3	62.2	65.7	62.8	60.0
			LWB	65.0	61.6	58.5	63.3	60.2	57.2	61.3	58.6	55.8
	4	3.1	TC	13.08	10.75	8.41	11.14	9.08	7.18	9.48	7.66	5.99
			SHC	8.35	7.50	6.54	6.94	6.18	5.40	5.79	5.11	4.41
			LDB	69.7	66.3	63.0	66.9	63.9	60.9	63.8	61.3	58.9
			LWB	63.6	60.4	57.5	61.9	59.0	56.2	59.9	57.4	54.9
	6	6.2	TC	14.23	11.49	8.98	11.85	9.57	7.48	9.95	8.03	6.28
			SHC	8.86	7.84	6.80	7.26	6.41	5.54	6.01	5.29	4.55
			LDB	68.8	65.7	62.6	66.0	63.3	60.5	63.0	60.7	58.3
			LWB	62.9	60.0	57.1	61.2	58.5	55.9	59.3	56.8	54.5
8	10.2	TC	14.61	11.79	9.22	12.21	9.86	7.71	10.15	8.20	6.41	
		SHC	9.03	7.98	6.92	7.43	6.54	5.65	6.11	5.37	4.62	
		LDB	68.5	65.4	62.3	65.6	62.9	60.2	62.6	60.4	58.1	
		LWB	62.7	59.8	56.9	60.9	58.2	55.6	59.0	56.6	54.3	
48	2	1.0	TC	9.78	7.71	5.88	8.57	6.87	5.18	7.47	5.93	4.53
			SHC	6.99	6.20	5.42	5.83	5.20	4.49	4.89	4.32	3.73
			LDB	72.2	68.7	65.1	69.8	66.4	63.3	67.1	64.2	61.3
			LWB	65.6	62.4	59.2	64.1	61.0	58.2	62.5	59.7	57.0
	4	3.1	TC	11.89	9.37	7.07	10.13	7.98	6.02	8.53	6.79	5.12
			SHC	7.84	6.90	5.93	6.49	5.68	4.86	5.35	4.70	4.00
			LDB	70.7	67.4	64.1	68.1	65.2	62.3	65.4	62.8	60.4
			LWB	64.4	61.3	58.4	62.8	60.0	57.3	61.1	58.5	56.2
	6	6.2	TC	12.79	10.08	7.69	10.78	8.49	6.41	8.95	7.13	5.32
			SHC	8.22	7.21	6.21	6.77	5.91	5.04	5.54	4.86	4.09
			LDB	70.0	66.8	63.6	67.3	64.6	61.8	64.7	62.2	60.0
			LWB	63.8	60.9	58.0	62.2	59.5	56.9	60.6	58.1	55.9
8	10.2	TC	13.28	10.47	7.89	11.10	8.75	6.60	9.23	7.28	5.43	
		SHC	8.44	7.38	6.30	6.92	6.02	5.12	5.67	4.92	4.14	
		LDB	69.6	66.5	63.5	66.9	64.3	61.6	64.3	62.0	59.8	
		LWB	63.5	60.6	57.8	61.9	59.3	56.8	60.2	57.9	55.7	

LEGEND

- EDB — Entering Dry Bulb (F)
- EWB — Entering Wet Bulb (F)
- EWT — Entering Water Temperature (F)
- LDB — Leaving Dry Bulb (F)
- LWB — Leaving Wet Bulb (F)
- PD — Water Pressure Drop (ft)
- SHC — Sensible Capacity (1000 Btuh)
- TC — Total Capacity (1000 Btuh)

NOTE: Direct interpolation is permissible. Do not extrapolate.



40UV COOLING CAPACITY — CHILLED WATER COILS (cont)

SIZE 050 — 4 ROW

EWT (F)	GPM	PD (ft)		CFM								
				500			350			250		
				Entering Air Temperature — EDB/EWB (F)								
				85/71	80/67	75/63	85/71	80/67	75/63	85/71	80/67	75/63
42	2	1.3	TC	14.46	12.03	9.82	12.74	10.59	8.57	10.95	9.07	7.37
			SHC	8.96	8.14	7.30	7.54	6.82	6.06	6.30	5.67	5.03
			LDB	68.6	65.1	61.6	65.3	62.2	59.2	62.0	59.3	56.6
			LWB	62.8	59.6	56.5	60.4	57.5	54.7	57.9	55.4	52.9
	4	4.2	TC	17.84	14.68	11.88	14.96	12.44	9.99	12.39	10.33	8.29
			SHC	10.33	9.25	8.20	8.49	7.64	6.70	6.94	6.24	5.46
			LDB	66.1	63.1	60.0	62.8	60.0	57.5	59.6	57.2	55.0
			LWB	60.6	57.8	55.0	58.3	55.6	53.2	55.9	53.5	51.4
	6	8.3	TC	19.07	15.86	12.74	15.92	13.10	10.51	12.97	10.77	8.56
			SHC	10.86	9.78	8.59	8.92	7.94	6.95	7.21	6.45	5.59
			LDB	65.1	62.1	59.3	61.7	59.3	56.9	58.6	56.4	54.6
			LWB	59.8	57.0	54.4	57.4	55.0	52.6	55.1	52.8	51.0
8	13.6	TC	19.83	16.49	13.24	16.40	13.49	10.83	13.23	10.89	8.74	
		SHC	11.20	10.07	8.82	9.14	8.12	7.10	7.34	6.51	5.67	
		LDB	64.5	61.6	58.9	61.1	58.8	56.5	58.2	56.2	54.3	
		LWB	59.3	56.5	54.0	56.9	54.5	52.3	54.7	52.7	50.7	
45	2	1.3	TC	13.08	10.75	8.50	11.60	9.47	7.40	9.95	8.11	6.41
			SHC	8.43	7.63	6.75	7.08	6.36	5.56	5.88	5.25	4.60
			LDB	69.6	66.0	62.7	66.5	63.4	60.5	63.5	60.8	58.2
			LWB	63.6	60.4	57.4	61.5	58.6	55.9	59.3	56.7	54.3
	4	4.2	TC	16.25	13.12	10.37	13.62	11.12	8.70	11.41	9.21	7.20
			SHC	9.66	8.59	7.53	7.91	7.05	6.12	6.50	5.73	4.95
			LDB	67.3	64.3	61.2	64.3	61.6	59.0	61.2	59.0	56.9
			LWB	61.7	58.9	56.1	59.6	57.0	54.6	57.3	55.2	53.1
	6	8.3	TC	17.44	14.08	11.09	14.50	11.70	9.15	11.94	9.64	7.54
			SHC	10.16	9.00	7.84	8.28	7.31	6.32	6.74	5.92	5.10
			LDB	66.4	63.5	60.7	63.4	60.9	58.5	60.4	58.3	56.3
			LWB	60.9	58.2	55.6	58.7	56.4	54.1	56.6	54.5	52.6
8	13.6	TC	18.06	14.74	11.53	14.93	12.05	9.43	12.19	9.84	7.69	
		SHC	10.42	9.28	8.04	8.47	7.46	6.44	6.85	6.01	5.18	
		LDB	65.9	63.0	60.3	62.9	60.5	58.2	60.0	58.0	56.1	
		LWB	60.5	57.8	55.2	58.3	56.0	53.8	56.2	54.2	52.4	
48	2	1.3	TC	11.76	9.37	7.20	10.34	8.24	6.21	8.95	7.13	5.38
			SHC	7.94	7.10	6.22	6.60	5.86	5.07	5.48	4.85	4.16
			LDB	70.5	67.0	63.6	67.8	64.7	61.8	65.0	62.3	59.8
			LWB	64.4	61.3	58.3	62.6	59.8	57.1	60.6	58.1	55.8
	4	4.2	TC	14.47	11.51	8.78	12.26	9.76	7.44	10.26	8.18	6.10
			SHC	8.96	7.93	6.86	7.34	6.48	5.58	6.01	5.28	4.47
			LDB	68.6	65.5	62.4	65.8	63.1	60.4	63.0	60.7	58.7
			LWB	62.8	59.9	57.2	60.8	58.3	55.9	58.9	56.6	54.7
	6	8.3	TC	15.68	12.50	9.43	13.07	10.38	7.83	10.73	8.46	6.38
			SHC	9.44	8.33	7.13	7.68	6.74	5.74	6.21	5.40	4.59
			LDB	67.7	64.8	62.0	64.9	62.4	60.0	62.3	60.2	58.2
			LWB	62.0	59.3	56.7	60.1	57.7	55.5	58.2	56.2	54.3
8	13.6	TC	16.32	12.94	9.87	13.47	10.70	8.01	11.08	8.63	6.54	
		SHC	9.69	8.51	7.32	7.84	6.87	5.82	6.36	5.48	4.66	
		LDB	67.3	64.4	61.6	64.5	62.1	59.8	61.7	60.0	58.0	
		LWB	61.6	59.0	56.4	59.7	57.4	55.3	57.8	56.0	54.1	

LEGEND

- EDB — Entering Dry Bulb (F)
- EWB — Entering Wet Bulb (F)
- EWT — Entering Water Temperature (F)
- LDB — Leaving Dry Bulb (F)
- LWB — Leaving Wet Bulb (F)
- PD — Water Pressure Drop (ft)
- SHC — Sensible Capacity (1000 Btuh)
- TC — Total Capacity (1000 Btuh)

NOTE: Direct interpolation is permissible. Do not extrapolate.

Performance data (cont)



40UV COOLING CAPACITY — CHILLED WATER COILS (cont)

SIZE 050 — 5 ROW

EWT (F)	GPM	PD (ft)		CFM								
				500			350			250		
				Entering Air Temperature — EDB/EWB (F)								
				85/71	80/67	75/63	85/71	80/67	75/63	85/71	80/67	75/63
42	2	0.9	TC	15.52	12.91	10.48	13.65	11.29	9.17	11.71	9.74	7.82
			SHC	9.15	8.32	7.44	7.65	6.91	6.16	6.36	5.74	5.06
			LDB	68.3	64.8	61.4	65.0	61.9	58.9	61.7	59.0	56.5
			LWB	62.1	59.0	56.0	59.5	56.8	54.1	56.9	54.4	52.2
	4	2.8	TC	19.29	16.04	12.88	16.22	13.34	10.75	13.38	11.01	8.84
			SHC	10.56	9.55	8.42	8.67	7.75	6.82	7.05	6.28	5.50
			LDB	65.7	62.5	59.6	62.3	59.8	57.2	59.2	57.0	54.9
			LWB	59.7	56.8	54.3	57.1	54.7	52.4	54.5	52.5	50.6
	6	5.6	TC	20.92	17.21	13.86	17.16	14.12	11.38	13.95	11.48	9.18
			SHC	11.22	10.03	8.83	9.07	8.08	7.09	7.30	6.49	5.65
			LDB	64.5	61.7	58.8	61.3	58.9	56.5	58.3	56.3	54.3
			LWB	58.6	56.0	53.5	56.1	53.9	51.7	53.6	51.8	50.0
8	9.3	TC	21.61	17.95	14.41	17.76	14.61	11.73	14.30	11.77	9.45	
		SHC	11.50	10.34	9.07	9.32	8.29	7.25	7.46	6.62	5.77	
		LDB	64.0	61.1	58.4	60.6	58.3	56.1	57.7	55.8	53.9	
		LWB	58.1	55.5	53.1	55.5	53.3	51.3	53.1	51.3	49.6	
45	2	0.9	TC	14.07	11.49	9.12	12.43	10.07	7.93	10.66	8.64	6.81
			SHC	8.63	7.79	6.92	7.20	6.44	5.66	5.95	5.30	4.64
			LDB	69.2	65.7	62.3	66.2	63.2	60.2	63.2	60.6	58.0
			LWB	63.0	59.9	56.9	60.7	58.0	55.4	58.3	56.0	53.7
	4	2.8	TC	17.56	14.23	11.21	14.71	11.96	9.35	12.19	9.87	7.78
			SHC	9.90	8.82	7.73	8.06	7.18	6.23	6.55	5.80	5.04
			LDB	66.9	63.9	60.9	63.9	61.2	58.7	61.0	58.8	56.6
			LWB	60.8	58.1	55.5	58.5	56.1	53.9	56.2	54.2	52.2
	6	5.6	TC	18.97	15.38	12.07	15.71	12.68	9.92	12.80	10.33	8.08
			SHC	10.44	9.28	8.08	8.46	7.47	6.47	6.81	5.99	5.17
			LDB	65.9	63.0	60.2	62.9	60.5	58.1	60.1	58.1	56.1
			LWB	59.9	57.3	54.8	57.6	55.4	53.3	55.3	53.5	51.8
8	9.3	TC	19.90	16.06	12.56	16.18	13.06	10.21	13.08	10.56	8.26	
		SHC	10.80	9.56	8.29	8.65	7.63	6.59	6.93	6.09	5.24	
		LDB	65.2	62.5	59.8	62.4	60.1	57.8	59.7	57.7	55.8	
		LWB	59.3	56.8	54.5	57.1	55.0	53.0	54.9	53.2	51.5	
48	2	0.9	TC	12.59	10.08	7.84	11.10	8.81	6.72	9.62	7.64	5.76
			SHC	8.13	7.29	6.44	6.72	5.97	5.19	5.56	4.91	4.23
			LDB	70.1	66.7	63.2	67.4	64.4	61.4	64.7	62.0	59.5
			LWB	63.9	60.9	57.8	61.9	59.2	56.6	59.7	57.4	55.2
	4	2.8	TC	15.74	12.50	9.49	13.32	10.50	8.01	11.08	8.73	6.58
			SHC	9.23	8.16	7.06	7.53	6.60	5.69	6.11	5.34	4.55
			LDB	68.1	65.1	62.1	65.3	62.7	60.1	62.6	60.5	58.4
			LWB	62.0	59.3	56.7	59.9	57.6	55.3	57.8	55.8	54.0
	6	5.6	TC	17.12	13.59	10.30	14.12	11.25	8.43	11.55	9.10	6.86
			SHC	9.73	8.58	7.37	7.83	6.90	5.86	6.30	5.48	4.66
			LDB	67.2	64.3	61.5	64.5	62.0	59.7	62.0	59.9	57.9
			LWB	61.1	58.5	56.1	59.1	56.8	54.9	57.1	55.3	53.6
8	9.3	TC	17.89	14.15	10.75	14.71	11.59	8.73	11.81	9.30	7.02	
		SHC	10.02	8.79	7.55	8.06	7.03	5.98	6.40	5.56	4.72	
		LDB	66.7	63.9	61.2	63.9	61.6	59.4	61.6	59.6	57.7	
		LWB	60.6	58.2	55.8	58.5	56.5	54.5	56.7	55.0	53.4	

LEGEND

- EDB — Entering Dry Bu b (F)
- EWB — Entering Wet Bulb (F)
- EWT — Entering Water Temperature (F)
- LDB — Leaving Dry Bu b (F)
- LWB — Leaving Wet Bulb (F)
- PD — Water Pressure Drop (ft)
- SHC — Sensible Capacity (1000 Btuh)
- TC — Total Capacity (1000 Btuh)

NOTE: Direct interpolation is permissible. Do not extrapolate.



40UV COOLING CAPACITY — CHILLED WATER COILS (cont)

SIZE 050 — HIGH CAPACITY COIL

EWT (F)	GPM	PD (ft)		CFM								
				500			350			250		
				Entering Air Temperature — EDB/EWB (F)								
				85/71	80/67	75/63	85/71	80/67	75/63	85/71	80/67	75/63
42	2	0.9	TC	17.38	14.52	11.93	15.27	12.70	10.31	13.14	10.89	8.84
			SHC	10.47	9.56	8.62	8.67	7.86	7.01	7.17	6.46	5.73
			LDB	65.8	62.5	59.2	62.3	59.5	56.7	58.8	56.4	54.0
			LWB	60.9	57.9	54.9	58.0	55.3	52.9	54.8	52.7	50.6
	4	2.8	TC	22.30	18.50	14.91	18.53	15.35	12.37	15.16	12.51	10.09
			SHC	12.29	11.10	9.82	9.94	8.94	7.87	8.00	7.14	6.27
			LDB	62.5	59.7	57.0	59.0	56.7	54.4	55.7	53.9	52.1
			LWB	57.6	55.1	52.7	54.7	52.5	50.6	51.8	50.1	48.5
	6	5.6	TC	24.37	20.17	16.25	19.82	16.36	13.17	15.92	13.10	10.51
			SHC	13.12	11.78	10.39	10.48	9.37	8.22	8.33	7.40	6.46
			LDB	61.0	58.4	56.0	57.6	55.5	53.5	54.5	52.9	51.4
			LWB	56.2	53.9	51.7	53.3	51.4	49.7	50.6	49.2	47.8
8	9.3	TC	25.46	21.10	16.94	20.50	16.87	13.54	16.27	13.39	10.75	
		SHC	13.56	12.18	10.69	10.77	9.59	8.38	8.49	7.53	6.57	
		LDB	60.2	57.7	55.5	56.9	55.0	53.1	54.0	52.5	51.0	
		LWB	55.4	53.2	51.2	52.6	50.9	49.2	50.0	48.7	47.4	
45	2	0.9	TC	15.74	12.97	10.46	13.88	11.35	8.97	11.94	9.73	7.66
			SHC	9.90	9.00	8.06	8.16	7.35	6.48	6.70	6.00	5.25
			LDB	66.9	63.5	60.3	63.7	60.8	58.1	60.5	58.1	55.8
			LWB	62.0	58.9	56.0	59.3	56.7	54.3	56.5	54.4	52.4
	4	2.8	TC	20.31	16.46	12.96	16.93	13.72	10.77	13.88	11.25	8.79
			SHC	11.53	10.29	9.03	9.30	8.27	7.20	7.46	6.61	5.71
			LDB	63.9	61.2	58.5	60.7	58.4	56.2	57.7	55.8	54.1
			LWB	59.0	56.6	54.2	56.3	54.3	52.4	53.7	52.1	50.6
	6	5.6	TC	22.20	17.98	14.17	18.12	14.68	11.48	14.55	11.75	9.18
			SHC	12.25	10.89	9.52	9.78	8.66	7.49	7.74	6.82	5.88
			LDB	62.6	60.1	57.6	59.5	57.4	55.4	56.7	55.1	53.5
			LWB	57.7	55.5	53.3	55.1	53.3	51.6	52.7	51.3	50.0
8	9.3	TC	23.26	18.86	14.80	18.71	15.16	11.92	14.93	12.05	9.43	
		SHC	12.67	11.24	9.78	10.02	8.86	7.68	7.90	6.95	5.98	
		LDB	61.8	59.4	57.1	58.8	56.9	54.9	56.1	54.6	53.1	
		LWB	57.0	54.8	52.8	54.5	52.7	51.1	52.1	50.8	49.6	
48	2	0.9	TC	14.16	11.47	9.02	12.43	9.94	7.68	10.73	8.55	6.51
			SHC	9.37	8.46	7.52	7.65	6.83	5.99	6.26	5.54	4.80
			LDB	67.9	64.5	61.2	65.0	62.2	59.4	62.1	59.7	57.5
			LWB	62.9	59.9	57.0	60.7	58.1	55.6	58.2	56.1	54.1
	4	2.8	TC	18.26	14.49	10.97	15.22	12.09	9.12	12.52	9.87	7.47
			SHC	10.78	9.55	8.25	8.65	7.63	6.54	6.93	6.05	5.17
			LDB	65.3	62.5	59.9	62.4	60.1	57.9	59.7	57.9	56.1
			LWB	60.4	57.9	55.6	58.0	56.0	54.1	55.7	54.2	52.7
	6	5.6	TC	20.03	15.90	12.04	16.35	12.93	9.79	13.12	10.38	7.83
			SHC	11.43	10.08	8.67	9.08	7.95	6.80	7.16	6.26	5.32
			LDB	64.1	61.6	59.2	61.3	59.2	57.2	58.8	57.1	55.5
			LWB	59.2	56.9	54.9	56.9	55.1	53.4	54.8	53.4	52.1
8	9.3	TC	21.01	16.61	12.57	16.95	13.36	10.07	13.47	10.62	8.01	
		SHC	11.80	10.35	8.87	9.31	8.12	6.92	7.30	6.35	5.39	
		LDB	63.4	61.1	58.8	60.7	58.8	56.9	58.3	56.8	55.3	
		LWB	58.5	56.4	54.5	56.3	54.7	53.1	54.3	53.1	51.9	

LEGEND

- EDB** — Entering Dry Bu b (F)
- EWB** — Entering Wet Bulb (F)
- EWT** — Entering Water Temperature (F)
- LDB** — Leaving Dry Bu b (F)
- LWB** — Leaving Wet Bulb (F)
- PD** — Water Pressure Drop (ft)
- SHC** — Sensible Capacity (1000 Btuh)
- TC** — Total Capacity (1000 Btuh)

NOTE: Direct interpolation is permissible. Do not extrapolate.

Performance data (cont)



40UV,UH COOLING CAPACITY — CHILLED WATER COILS

SIZE 075 — 3 ROW

EWT (F)	GPM	PD (ft)		CFM								
				750			525			375		
				Entering Air Temperature — EDB/EWB (F)								
				85/71	80/67	75/63	85/71	80/67	75/63	85/71	80/67	75/63
42	2	1.4	TC	19.63	16.65	13.92	17.82	15.07	12.37	16.03	13.33	10.85
			SHC	12.91	11.92	10.89	10.77	9.91	8.94	9.08	8.24	7.36
			LDB	69.3	65.5	61.7	66.2	62.7	59.4	62.9	59.9	57.0
			LWB	63.6	60.2	56.8	61.2	58.0	55.0	58.3	55.6	53.1
	4	4.3	TC	26.47	22.20	18.03	23.16	19.26	15.60	19.63	16.33	13.16
			SHC	15.25	13.93	12.45	12.71	11.50	10.21	10.46	9.43	8.31
			LDB	66.4	63.0	59.8	62.9	60.0	57.2	59.5	57.0	54.7
			LWB	60.8	57.7	54.9	57.8	55.2	52.8	54.9	52.7	50.7
	6	8.5	TC	29.85	24.87	20.19	25.31	21.05	17.00	21.08	17.40	14.08
			SHC	16.50	14.96	13.32	13.54	12.22	10.80	11.05	9.88	8.71
			LDB	64.9	61.8	58.8	61.4	58.7	56.2	58.0	55.9	53.8
			LWB	59.3	56.5	53.8	56.4	54.0	51.7	53.5	51.6	49.7
8	14.0	TC	31.71	26.38	21.41	26.64	21.99	17.79	21.97	18.07	14.51	
		SHC	17.21	15.56	13.82	14.08	12.61	11.13	11.43	10.17	8.90	
		LDB	64.0	61.0	58.1	60.5	58.0	55.6	57.1	55.2	53.3	
		LWB	58.4	55.8	53.2	55.5	53.3	51.2	52.6	50.9	49.2	
45	2	1.4	TC	17.91	14.92	12.25	16.18	13.35	10.77	14.45	11.92	9.42
			SHC	12.36	11.33	10.28	10.21	9.29	8.33	8.51	7.71	6.81
			LDB	69.9	66.2	62.5	67.2	63.8	60.5	64.2	61.2	58.4
			LWB	64.3	60.9	57.6	62.2	59.1	56.1	59.7	56.9	54.5
	4	4.3	TC	24.10	19.68	15.56	21.09	17.22	13.46	17.91	14.60	11.45
			SHC	14.42	13.00	11.50	11.93	10.71	9.36	9.78	8.73	7.61
			LDB	67.4	64.1	61.0	64.2	61.4	58.7	61.1	58.7	56.4
			LWB	61.8	58.9	56.1	59.1	56.6	54.3	56.5	54.4	52.4
	6	8.5	TC	27.09	22.11	17.35	23.05	18.82	14.77	19.20	15.67	12.25
			SHC	15.48	13.90	12.19	12.66	11.32	9.88	10.29	9.16	7.94
			LDB	66.1	63.0	60.1	62.9	60.3	57.8	59.9	57.7	55.6
			LWB	60.5	57.7	55.2	57.9	55.5	53.4	55.3	53.3	51.6
8	14.0	TC	28.89	23.57	18.64	24.27	19.65	15.48	19.98	16.19	12.75	
		SHC	16.14	14.46	12.70	13.13	11.65	10.17	10.60	9.37	8.14	
		LDB	65.3	62.4	59.5	62.1	59.7	57.3	59.2	57.1	55.1	
		LWB	59.7	57.1	54.6	57.1	54.9	52.8	54.6	52.8	51.1	
48	2	1.4	TC	16.10	13.35	10.64	14.51	11.76	9.32	12.93	10.38	8.06
			SHC	11.79	10.80	10.64	9.66	8.73	7.80	7.99	7.15	6.30
			LDB	70.6	66.8	62.0	68.2	64.8	61.4	65.5	62.6	59.6
			LWB	65.0	61.6	58.3	63.2	60.1	57.1	61.0	58.4	55.8
	4	4.3	TC	21.47	17.11	13.17	18.79	14.97	11.29	16.10	12.83	9.68
			SHC	13.52	12.08	10.61	11.10	9.87	8.52	9.10	8.05	6.91
			LDB	68.5	65.3	62.1	65.7	62.8	60.2	62.8	60.4	58.2
			LWB	62.9	60.0	57.2	60.6	58.1	55.8	58.2	56.1	54.2
	6	8.5	TC	24.21	19.29	14.55	20.81	16.51	12.45	17.32	13.75	10.41
			SHC	14.46	12.86	11.12	11.83	10.44	8.97	9.56	8.40	7.19
			LDB	67.4	64.3	61.4	64.4	61.8	59.4	61.7	59.5	57.5
			LWB	61.7	59.0	56.5	59.3	57.1	55.0	57.1	55.2	53.5
8	14.0	TC	25.87	20.70	15.61	21.79	17.39	13.11	18.02	14.31	10.79	
		SHC	15.04	13.37	11.52	12.19	10.77	9.22	9.83	8.62	7.34	
		LDB	66.7	63.7	61.0	63.8	61.2	58.9	61.0	59.0	57.1	
		LWB	61.0	58.4	56.0	58.7	56.5	54.5	56.4	54.7	53.1	

LEGEND

- EDB — Entering Dry Bulb (F)
- EWB — Entering Wet Bulb (F)
- EWT — Entering Water Temperature (F)
- LDB — Leaving Dry Bulb (F)
- LWB — Leaving Wet Bulb (F)
- PD — Water Pressure Drop (ft)
- SHC — Sensible Capacity (1000 Btuh)
- TC — Total Capacity (1000 Btuh)

NOTE: Direct interpolation is permissible. Do not extrapolate.



40UV,UH COOLING CAPACITY — CHILLED WATER COILS (cont)

SIZE 075 — 4 ROW

EWT (F)	GPM	PD (ft)		CFM								
				750			525			375		
				Entering Air Temperature — EDB/EWB (F)								
				85/71	80/67	75/63	85/71	80/67	75/63	85/71	80/67	75/63
42	2	1.8	TC	21.46	18.22	15.14	19.46	16.30	13.38	17.30	14.45	11.73
			SHC	14.41	13.30	12.10	12.06	11.02	9.92	10.13	9.21	8.20
			LDB	67.4	63.8	60.2	64.0	60.8	57.7	60.3	57.5	55.0
			LWB	62.9	59.5	56.3	60.2	57.2	54.3	57.1	54.5	52.2
	4	5.7	TC	29.25	24.38	19.65	25.21	20.90	16.90	21.16	17.53	14.17
			SHC	17.29	15.70	13.94	14.32	12.90	11.42	11.73	10.53	9.28
			LDB	63.9	60.9	58.0	60.1	57.5	55.1	56.4	54.3	52.4
			LWB	59.5	56.7	54.1	56.5	54.1	51.8	53.4	51.4	49.6
	6	11.3	TC	32.84	27.32	22.10	27.49	22.86	18.36	22.61	18.67	15.02
			SHC	18.73	16.93	15.00	15.28	13.76	12.07	12.38	11.04	9.67
			LDB	62.2	59.4	56.7	58.4	56.0	54.0	54.8	53.1	51.4
			LWB	57.9	55.3	52.9	54.9	52.7	50.7	51.9	50.2	48.7
8	18.7	TC	34.87	28.90	23.46	28.76	23.83	19.13	23.33	19.26	15.47	
		SHC	19.58	17.61	15.60	15.84	14.19	12.43	12.71	11.32	9.88	
		LDB	61.1	58.5	56.0	57.4	55.3	53.4	54.0	52.4	50.9	
		LWB	57.0	54.5	52.2	54.0	52.0	50.1	51.2	49.6	48.2	
45	2	1.8	TC	19.55	16.31	13.33	17.59	14.52	11.64	15.70	12.82	10.17
			SHC	13.74	12.59	11.39	11.37	10.33	9.22	9.51	8.55	7.55
			LDB	68.2	64.6	61.1	65.2	62.0	58.9	61.8	59.2	56.6
			LWB	63.6	60.3	57.1	61.3	58.4	55.5	58.6	56.1	53.7
	4	5.7	TC	26.53	21.58	17.00	22.89	18.61	14.60	19.27	15.67	12.30
			SHC	16.25	14.59	12.84	13.38	11.94	10.43	10.93	9.72	8.44
			LDB	65.2	62.2	59.3	61.7	59.2	56.8	58.3	56.3	54.4
			LWB	60.7	58.0	55.4	58.0	55.7	53.5	55.3	53.3	51.6
	6	11.3	TC	29.85	24.33	19.09	25.07	20.43	15.98	20.66	16.68	13.09
			SHC	17.53	15.68	13.71	14.26	12.70	11.02	11.52	10.15	8.79
			LDB	63.6	60.9	58.3	60.2	57.9	55.8	56.9	55.2	53.6
			LWB	59.3	56.7	54.4	56.6	54.4	52.5	53.9	52.3	50.7
8	18.7	TC	31.75	25.83	20.27	26.19	21.30	16.71	21.33	17.22	13.51	
		SHC	18.29	16.30	14.21	14.73	13.07	11.34	11.81	10.39	8.98	
		LDB	62.7	60.1	57.7	59.3	57.2	55.2	56.2	54.7	53.1	
		LWB	58.4	56.0	53.8	55.8	53.8	51.9	53.2	51.7	50.3	
48	2	1.8	TC	17.65	14.47	11.53	15.81	12.78	10.00	14.00	11.25	8.64
			SHC	13.10	11.93	10.71	10.74	9.68	8.58	8.88	7.94	6.93
			LDB	69.0	65.4	61.9	66.3	63.1	60.1	63.4	60.6	58.1
			LWB	64.4	61.1	57.9	62.4	59.5	56.7	60.1	57.6	55.2
	4	5.7	TC	23.61	18.87	14.39	20.59	16.28	12.28	17.38	13.80	10.37
			SHC	15.17	13.54	11.80	12.48	11.01	9.48	10.16	8.94	7.63
			LDB	66.5	63.5	60.6	63.3	60.8	58.5	60.2	58.2	56.4
			LWB	62.0	59.2	56.6	59.5	57.2	55.1	57.0	55.2	53.5
	6	11.3	TC	26.84	21.38	16.01	22.54	17.96	13.55	18.65	14.69	11.12
			SHC	16.36	14.51	12.44	13.24	11.68	9.99	10.67	9.31	7.94
			LDB	65.0	62.3	59.8	61.9	59.7	57.6	59.0	57.3	55.6
			LWB	60.6	58.1	55.8	58.2	56.1	54.2	55.9	54.3	52.8
8	18.7	TC	28.55	22.75	17.16	23.72	18.76	14.15	19.24	15.16	11.48	
		SHC	17.02	15.05	12.91	13.71	12.00	10.24	10.92	9.50	8.09	
		LDB	64.2	61.7	59.3	61.1	59.1	57.2	58.4	56.8	55.3	
		LWB	59.8	57.5	55.3	57.4	55.5	53.8	55.3	53.8	52.4	

LEGEND

- EDB — Entering Dry Bulb (F)
- EWB — Entering Wet Bulb (F)
- EWT — Entering Water Temperature (F)
- LDB — Leaving Dry Bulb (F)
- LWB — Leaving Wet Bulb (F)
- PD — Water Pressure Drop (ft)
- SHC — Sensible Capacity (1000 Btuh)
- TC — Total Capacity (1000 Btuh)

NOTE: Direct interpolation is permissible. Do not extrapolate.

Performance data (cont)



40UV,UH COOLING CAPACITY — CHILLED WATER COILS (cont)

SIZE 075 — 5 ROW

EWT (F)	GPM	PD (ft)		CFM								
				750			525			375		
				Entering Air Temperature — EDB/EWB (F)								
				85/71	80/67	75/63	85/71	80/67	75/63	85/71	80/67	75/63
42	2	1.2	TC	22.39	18.93	15.72	20.17	16.94	13.91	17.95	14.98	12.15
			SHC	13.67	12.59	11.45	11.40	10.43	9.39	9.58	8.70	7.74
			LDB	68.3	64.7	61.0	65.1	61.8	58.6	61.6	58.8	56.1
			LWB	62.5	59.2	56.0	59.7	56.8	54.0	56.5	54.0	51.7
	4	3.9	TC	30.79	25.63	20.73	26.36	21.91	17.72	22.03	18.26	14.71
			SHC	16.54	15.00	13.33	13.65	12.31	10.88	11.15	10.00	8.78
			LDB	64.8	61.7	58.7	61.2	58.6	56.0	57.8	55.6	53.6
			LWB	58.9	56.1	53.5	55.7	53.3	51.2	52.5	50.7	49.0
	6	7.7	TC	34.75	28.90	23.37	28.97	23.92	19.28	23.52	19.43	15.65
			SHC	18.02	16.27	14.39	14.67	13.12	11.53	11.77	10.49	9.18
			LDB	63.0	60.2	57.5	59.4	57.1	54.9	56.3	54.4	52.6
			LWB	57.1	54.5	52.2	53.9	51.9	50.0	51.0	49.4	48.0
8	12.7	TC	36.91	30.59	24.74	30.26	24.99	20.14	24.31	20.01	16.12	
		SHC	18.86	16.94	14.95	15.20	13.57	11.89	12.11	10.74	9.39	
		LDB	62.0	59.3	56.8	58.5	56.4	54.3	55.5	53.8	52.1	
		LWB	56.0	53.7	51.5	52.9	51.1	49.4	50.1	48.8	47.4	
45	2	1.2	TC	20.32	17.04	13.83	18.32	15.11	12.15	16.29	13.29	10.55
			SHC	13.01	11.95	10.77	10.77	9.78	8.73	8.99	8.07	7.12
			LDB	69.1	65.4	61.9	66.2	63.0	59.8	63.1	60.3	57.6
			LWB	63.3	60.0	56.9	60.9	58.0	55.2	58.0	55.6	53.4
	4	3.9	TC	27.93	22.72	17.89	23.97	19.59	15.32	20.12	16.33	12.85
			SHC	15.53	13.93	12.25	12.74	11.41	9.93	10.40	9.22	8.02
			LDB	66.1	63.0	60.1	62.8	60.1	57.7	59.6	57.5	55.4
			LWB	60.1	57.5	54.9	57.3	55.0	53.0	54.4	52.7	51.0
	6	7.7	TC	31.63	25.73	20.20	26.38	21.38	16.84	21.48	17.41	13.67
			SHC	16.85	15.04	13.13	13.65	12.10	10.53	10.93	9.65	8.35
			LDB	64.5	61.7	59.0	61.2	58.9	56.7	58.3	56.5	54.6
			LWB	58.5	56.1	53.8	55.7	53.7	51.9	53.1	51.6	50.1
8	12.7	TC	33.66	27.34	21.53	27.66	22.33	17.52	22.23	17.95	14.08	
		SHC	17.61	15.65	13.65	14.15	12.48	10.80	11.23	9.87	8.52	
		LDB	63.5	60.9	58.4	60.4	58.3	56.2	57.6	55.9	54.2	
		LWB	57.6	55.3	53.1	54.8	53.0	51.3	52.3	51.0	49.7	
48	2	1.2	TC	18.36	15.06	12.02	16.40	13.31	10.43	14.54	11.67	9.00
			SHC	12.40	11.29	10.13	10.15	9.16	8.12	8.39	7.49	6.55
			LDB	69.9	66.2	62.6	67.3	64.0	60.9	64.5	61.7	59.0
			LWB	64.1	60.9	57.7	62.0	59.1	56.4	59.6	57.2	54.9
	4	3.9	TC	24.90	19.84	15.15	21.55	17.04	12.90	18.16	14.41	10.79
			SHC	14.49	12.90	11.24	11.88	10.46	9.01	9.66	8.49	7.21
			LDB	67.3	64.3	61.3	64.3	61.8	59.3	61.4	59.3	57.4
			LWB	61.4	58.8	56.3	58.9	56.7	54.7	56.3	54.6	53.1
	6	7.7	TC	28.34	22.58	16.97	23.72	18.83	14.15	19.46	15.33	11.61
			SHC	15.67	13.88	11.91	12.65	11.12	9.48	10.14	8.83	7.53
			LDB	65.9	63.1	60.5	63.0	60.6	58.5	60.3	58.5	56.6
			LWB	59.9	57.5	55.4	57.4	55.5	53.8	55.1	53.7	52.3
8	12.7	TC	30.27	24.11	18.12	24.98	19.74	14.89	20.06	15.81	11.97	
		SHC	16.36	14.44	12.33	13.12	11.46	9.76	10.37	9.02	7.67	
		LDB	65.1	62.4	60.0	62.1	60.0	58.0	59.7	58.0	56.3	
		LWB	59.1	56.8	54.8	56.6	54.9	53.3	54.5	53.2	51.9	

LEGEND

- EDB — Entering Dry Bulb (F)
- EWB — Entering Wet Bulb (F)
- EWT — Entering Water Temperature (F)
- LDB — Leaving Dry Bulb (F)
- LWB — Leaving Wet Bulb (F)
- PD — Water Pressure Drop (ft)
- SHC — Sensible Capacity (1000 Btuh)
- TC — Total Capacity (1000 Btuh)

NOTE: Direct interpolation is permissible. Do not extrapolate.



40UV,UH COOLING CAPACITY — CHILLED WATER COILS (cont)

SIZE 075 — HIGH CAPACITY COIL

EWT (F)	GPM	PD (ft)		CFM								
				750			525			375		
				Entering Air Temperature — EDB/EWB (F)								
				85/71	80/67	75/63	85/71	80/67	75/63	85/71	80/67	75/63
42	2	1.2	TC	24.50	20.94	17.48	22.08	18.64	15.35	19.55	16.33	13.36
			SHC	15.29	14.17	12.92	12.60	11.57	10.44	10.48	9.52	8.52
			LDB	66.4	62.7	59.2	63.0	59.8	56.8	59.4	56.8	54.2
			LWB	61.6	58.3	55.1	58.5	55.6	52.9	55.0	52.6	50.5
	4	3.9	TC	34.23	28.59	23.21	29.29	24.37	19.71	24.31	20.11	16.25
			SHC	18.58	16.89	15.07	15.21	13.73	12.15	12.31	11.01	9.69
			LDB	62.3	59.4	56.6	58.5	56.1	53.8	55.0	53.1	51.4
			LWB	57.3	54.7	52.3	53.6	51.5	49.7	50.1	48.7	47.3
	6	7.7	TC	39.27	32.66	26.41	32.30	26.77	21.65	25.90	21.42	17.20
			SHC	20.44	18.46	16.34	16.38	14.70	12.95	12.96	11.57	10.10
			LDB	60.1	57.5	55.1	56.5	54.4	52.5	53.4	51.8	50.4
			LWB	54.9	52.7	50.6	51.4	49.7	48.2	48.4	47.2	46.2
8	12.7	TC	42.00	34.81	28.16	33.92	28.01	22.57	26.72	22.01	17.63	
		SHC	21.49	19.31	17.05	17.05	15.21	13.34	13.31	11.82	10.28	
		LDB	58.8	56.5	54.2	55.3	53.5	51.8	52.5	51.2	49.9	
		LWB	53.6	51.6	49.7	50.2	48.8	47.4	47.5	46.5	45.7	
45	2	1.2	TC	22.40	18.86	15.50	20.08	16.68	13.51	17.76	14.60	11.65
			SHC	14.63	13.47	12.21	11.93	10.88	9.76	9.84	8.87	7.86
			LDB	67.2	63.6	60.1	64.2	61.0	58.0	61.0	58.4	55.8
			LWB	62.5	59.2	56.1	59.8	56.9	54.2	56.7	54.4	52.2
	4	3.9	TC	31.06	25.45	20.20	26.67	21.70	17.09	22.14	18.01	14.14
			SHC	17.47	15.74	13.92	14.22	12.70	11.11	11.45	10.17	8.83
			LDB	63.7	60.8	58.0	60.2	57.9	55.7	57.1	55.2	53.5
			LWB	58.7	56.2	53.8	55.5	53.5	51.7	52.4	50.9	49.6
	6	7.7	TC	35.68	29.07	22.82	29.53	23.98	18.85	23.70	19.20	15.05
			SHC	19.10	17.08	14.92	15.29	13.58	11.80	12.06	10.64	9.20
			LDB	61.7	59.2	56.8	58.4	56.4	54.4	55.6	54.0	52.6
			LWB	56.6	54.4	52.5	53.5	51.8	50.3	50.8	49.6	48.6
8	12.7	TC	38.38	31.11	24.51	31.00	25.12	19.71	24.43	19.79	15.48	
		SHC	20.10	17.85	15.57	15.87	14.03	12.15	12.35	10.88	9.37	
		LDB	60.5	58.2	56.0	57.4	55.6	53.8	54.9	53.5	52.1	
		LWB	55.3	53.4	51.6	52.4	51.0	49.7	50.0	49.0	48.2	
48	2	1.2	TC	20.22	16.79	13.52	18.04	14.75	11.65	15.92	12.83	9.95
			SHC	13.96	12.79	11.53	11.27	10.22	9.09	9.21	8.24	7.22
			LDB	68.0	64.4	60.9	65.4	62.2	59.2	62.5	59.9	57.4
			LWB	63.4	60.1	57.0	61.0	58.2	55.5	58.4	56.1	53.9
	4	3.9	TC	27.69	22.25	17.22	23.89	18.97	14.46	19.99	15.81	11.92
			SHC	16.33	14.62	12.83	13.23	11.69	10.11	10.64	9.32	7.96
			LDB	65.1	62.2	59.4	62.0	59.6	57.4	59.1	57.3	55.6
			LWB	60.2	57.7	55.3	57.3	55.4	53.6	54.6	53.2	52.0
	6	7.7	TC	32.08	25.38	19.28	26.59	21.14	15.83	21.39	16.92	12.79
			SHC	17.82	15.72	13.58	14.19	12.49	10.62	11.16	9.74	8.29
			LDB	63.3	60.8	58.4	60.3	58.2	56.5	57.8	56.2	54.8
			LWB	58.3	56.2	54.3	55.5	53.9	52.6	53.2	52.0	51.1
8	12.7	TC	34.51	27.39	20.64	27.98	22.10	16.69	22.12	17.46	13.20	
		SHC	18.68	16.45	14.08	14.71	12.85	10.95	11.44	9.95	8.45	
		LDB	62.2	59.9	57.8	59.4	57.6	55.9	57.1	55.7	54.4	
		LWB	57.2	55.3	53.6	54.6	53.2	52.0	52.4	51.5	50.6	

LEGEND

- EDB — Entering Dry Bulb (F)
- EWB — Entering Wet Bulb (F)
- EWT — Entering Water Temperature (F)
- LDB — Leaving Dry Bulb (F)
- LWB — Leaving Wet Bulb (F)
- PD — Water Pressure Drop (ft)
- SHC — Sensible Capacity (1000 Btuh)
- TC — Total Capacity (1000 Btuh)

NOTE: Direct interpolation is permissible. Do not extrapolate.

Performance data (cont)



40UV,UH COOLING CAPACITY — CHILLED WATER COILS (cont)

SIZE 100 — 3 ROW

EWT (F)	GPM	PD (ft)		CFM								
				1000			700			500		
				Entering Air Temperature — EDB/EWB (F)								
				85/71	80/67	75/63	85/71	80/67	75/63	85/71	80/67	75/63
42	2	1.7	TC	22.86	19.46	16.22	20.97	17.67	14.56	19.07	15.98	13.00
			SHC	17.58	16.27	14.85	14.76	13.56	12.27	12.54	11.44	10.24
			LDB	68.9	65.1	61.4	65.7	62.3	59.0	62.1	59.1	56.3
			LWB	64.6	61.1	57.6	62.4	59.2	56.0	59.8	56.9	54.2
	4	5.4	TC	32.21	26.79	21.81	28.53	23.83	19.14	24.79	20.47	16.58
			SHC	21.22	19.29	17.27	17.88	16.23	14.33	15.03	13.47	11.91
			LDB	65.6	62.4	59.2	61.6	58.8	56.3	57.5	55.4	53.2
			LWB	61.7	58.7	55.7	59.0	56.2	53.7	55.9	53.6	51.4
	6	10.7	TC	37.20	30.94	25.03	31.95	26.57	21.50	26.99	22.28	18.03
			SHC	23.33	21.12	18.75	19.41	17.50	15.46	16.07	14.35	12.63
			LDB	63.7	60.7	57.9	59.6	57.1	54.8	55.6	53.8	51.9
			LWB	60.1	57.2	54.5	57.3	54.7	52.4	54.3	52.3	50.3
8	17.7	TC	40.10	33.28	26.92	33.87	28.07	22.67	28.11	23.21	18.77	
		SHC	24.62	22.19	19.64	20.31	18.22	16.03	16.62	14.81	13.00	
		LDB	62.5	59.7	57.0	58.5	56.2	54.1	54.6	52.9	51.2	
		LWB	59.2	56.4	53.8	56.3	54.0	51.7	53.5	51.6	49.7	
45	2	1.7	TC	20.77	17.52	14.38	18.96	15.79	12.77	17.25	14.18	11.33
			SHC	16.82	15.51	14.09	13.99	12.80	11.50	11.80	10.68	9.50
			LDB	69.6	65.8	62.1	66.7	63.3	60.0	63.4	60.5	57.6
			LWB	65.2	61.7	58.3	63.3	60.1	56.9	61.0	58.1	55.4
	4	5.4	TC	29.00	23.68	18.79	25.98	21.05	16.46	22.44	18.29	14.30
			SHC	19.93	17.98	15.94	16.78	14.99	13.11	13.97	12.46	10.83
			LDB	66.8	63.6	60.4	63.1	60.4	57.9	59.5	57.2	55.2
			LWB	62.7	59.7	56.7	60.2	57.5	55.1	57.6	55.2	53.2
	6	10.7	TC	33.87	27.55	21.54	29.10	23.67	18.57	24.55	19.89	15.69
			SHC	21.91	19.62	17.15	18.12	16.15	14.07	14.92	13.20	11.48
			LDB	65.0	62.1	59.3	61.3	58.9	56.6	57.7	55.9	54.0
			LWB	61.2	58.4	55.8	58.7	56.2	54.0	56.1	54.1	52.1
8	17.7	TC	36.52	29.81	23.31	30.84	25.09	19.69	25.60	20.81	16.34	
		SHC	23.04	20.61	17.95	18.90	16.80	14.59	15.41	13.64	11.80	
		LDB	63.9	61.2	58.6	60.3	58.1	55.9	56.8	55.1	53.4	
		LWB	60.4	57.6	55.1	57.8	55.5	53.4	55.3	53.4	51.6	
48	2	1.7	TC	18.81	15.60	12.47	17.01	13.89	11.05	15.39	12.41	9.63
			SHC	16.12	14.78	12.47	13.27	12.05	10.79	11.08	9.95	8.77
			LDB	70.3	66.5	63.6	67.7	64.3	60.9	64.7	61.8	59.0
			LWB	65.8	62.3	58.9	64.2	61.0	57.8	62.2	59.3	56.6
	4	5.4	TC	25.87	20.70	15.90	23.07	18.31	13.81	20.18	15.96	11.99
			SHC	18.71	16.76	14.71	15.59	13.83	11.95	12.99	11.43	9.79
			LDB	67.9	64.7	61.5	64.6	61.9	59.4	61.2	59.1	57.1
			LWB	63.7	60.7	57.8	61.5	58.9	56.4	59.1	56.9	54.9
	6	10.7	TC	30.23	23.74	17.90	26.13	20.77	15.53	22.16	17.52	13.22
			SHC	20.42	18.00	15.56	16.85	14.87	12.70	13.84	12.12	10.33
			LDB	66.3	63.5	60.8	63.0	60.6	58.4	59.7	57.8	56.1
			LWB	62.4	59.7	57.1	60.1	57.7	55.5	57.8	55.8	54.0
8	17.7	TC	32.64	25.97	19.40	27.75	22.02	16.61	23.09	18.34	13.83	
		SHC	21.40	18.94	16.21	17.54	15.41	13.17	14.26	12.49	10.61	
		LDB	65.4	62.7	60.2	62.1	59.9	57.8	58.9	57.2	55.6	
		LWB	61.6	59.0	56.5	59.3	57.1	55.0	57.1	55.2	53.5	

LEGEND

- EDB — Entering Dry Bulb (F)
- EWB — Entering Wet Bulb (F)
- EWT — Entering Water Temperature (F)
- LDB — Leaving Dry Bulb (F)
- LWB — Leaving Wet Bulb (F)
- PD — Water Pressure Drop (ft)
- SHC — Sensible Capacity (1000 Btuh)
- TC — Total Capacity (1000 Btuh)

NOTE: Direct interpolation is permissible. Do not extrapolate.



40UV,UH COOLING CAPACITY — CHILLED WATER COILS (cont)

SIZE 100 — 4 ROW

EWT (F)	GPM	PD (ft)		CFM								
				1000			700			500		
				Entering Air Temperature — EDB/EWB (F)								
				85/71	80/67	75/63	85/71	80/67	75/63	85/71	80/67	75/63
42	2	2.3	TC	25.65	22.01	18.43	23.43	19.84	16.44	21.22	17.81	14.57
			SHC	18.63	17.31	15.82	15.51	14.29	12.96	13.08	11.95	10.72
			LDB	68.0	64.2	60.5	64.7	61.3	58.1	61.1	58.1	55.4
			LWB	63.8	60.2	56.9	61.3	58.1	55.1	58.4	55.6	53.0
	4	7.3	TC	36.52	30.49	24.84	32.30	26.87	21.66	27.69	22.95	18.49
			SHC	22.62	20.60	18.45	18.97	17.16	15.19	15.76	14.16	12.46
			LDB	64.3	61.2	58.1	60.2	57.6	55.2	56.2	54.1	52.2
			LWB	60.4	57.4	54.6	57.1	54.6	52.3	53.8	51.8	49.9
	6	14.4	TC	42.75	35.56	28.60	36.31	30.15	24.30	30.14	24.89	20.09
			SHC	25.12	22.72	20.08	20.68	18.61	16.38	16.87	15.05	13.21
			LDB	62.0	59.2	56.6	58.0	55.7	53.6	54.2	52.5	50.8
			LWB	58.3	55.6	53.2	55.1	52.8	50.8	51.9	50.2	48.6
8	23.7	TC	46.15	38.25	30.94	38.34	31.77	25.60	31.36	25.90	20.87	
		SHC	26.55	23.89	21.13	21.59	19.35	16.99	17.44	15.53	13.58	
		LDB	60.7	58.1	55.7	56.8	54.7	52.8	53.1	51.6	50.2	
		LWB	57.1	54.6	52.3	54.0	52.0	50.1	51.0	49.4	48.0	
45	2	2.3	TC	23.44	19.82	16.34	21.29	17.80	14.46	19.26	15.89	12.73
			SHC	17.87	16.50	15.00	14.74	13.51	12.16	12.33	11.18	9.95
			LDB	68.7	64.9	61.3	65.7	62.4	59.1	62.4	59.6	56.8
			LWB	64.4	61.0	57.6	62.3	59.1	56.1	59.7	56.9	54.4
	4	7.3	TC	32.88	27.05	21.54	29.20	23.75	18.71	25.13	20.51	16.04
			SHC	21.23	19.23	17.08	17.71	15.85	13.91	14.66	13.08	11.36
			LDB	65.6	62.4	59.4	61.9	59.3	56.8	58.2	56.1	54.2
			LWB	61.5	58.6	55.8	58.6	56.2	53.9	55.7	53.6	51.9
	6	14.4	TC	38.77	31.43	24.58	32.93	26.89	21.02	27.45	22.25	17.52
			SHC	23.50	20.99	18.34	19.24	17.17	14.91	15.65	13.84	12.02
			LDB	63.5	60.8	58.2	59.9	57.6	55.5	56.4	54.7	53.0
			LWB	59.6	57.1	54.7	56.8	54.6	52.6	54.0	52.3	50.7
8	23.7	TC	41.88	34.18	26.73	34.91	28.40	22.37	28.64	23.21	18.16	
		SHC	24.76	22.13	19.26	20.08	17.83	15.50	16.18	14.27	12.31	
		LDB	62.4	59.8	57.4	58.8	56.7	54.7	55.4	53.9	52.5	
		LWB	58.6	56.1	53.9	55.8	53.8	51.9	53.1	51.6	50.2	
48	2	2.3	TC	21.23	17.65	14.11	19.14	15.73	12.53	17.24	13.94	10.89
			SHC	17.13	15.72	14.11	13.98	12.74	11.40	11.59	10.42	9.21
			LDB	69.3	65.6	62.1	66.7	63.4	60.1	63.8	60.9	58.2
			LWB	65.1	61.6	58.4	63.2	60.1	57.1	61.0	58.3	55.7
	4	7.3	TC	29.32	23.64	18.37	26.03	20.69	15.78	22.59	17.87	13.48
			SHC	19.93	17.92	15.80	16.49	14.62	12.69	13.62	11.97	10.26
			LDB	66.8	63.6	60.6	63.5	60.9	58.4	60.1	58.1	56.2
			LWB	62.6	59.7	56.9	60.1	57.7	55.4	57.4	55.5	53.8
	6	14.4	TC	34.49	27.30	20.67	29.73	23.51	17.67	24.77	19.59	14.72
			SHC	21.84	19.33	16.72	17.92	15.75	13.47	14.51	12.69	10.79
			LDB	65.0	62.3	59.7	61.6	59.4	57.4	58.5	56.8	55.3
			LWB	61.0	58.5	56.1	58.4	56.3	54.4	55.9	54.3	52.9
8	23.7	TC	37.65	29.78	22.29	31.50	25.01	18.80	25.85	20.37	15.42	
		SHC	23.06	20.31	17.38	18.64	16.38	13.95	14.96	13.02	11.09	
		LDB	63.9	61.4	59.1	60.6	58.6	56.8	57.6	56.2	54.7	
		LWB	60.0	57.6	55.5	57.5	55.5	53.8	55.1	53.7	52.3	

LEGEND

- EDB — Entering Dry Bulb (F)
- EWB — Entering Wet Bulb (F)
- EWT — Entering Water Temperature (F)
- LDB — Leaving Dry Bulb (F)
- LWB — Leaving Wet Bulb (F)
- PD — Water Pressure Drop (ft)
- SHC — Sensible Capacity (1000 Btuh)
- TC — Total Capacity (1000 Btuh)

NOTE: Direct interpolation is permissible. Do not extrapolate.

Performance data (cont)



40UV,UH COOLING CAPACITY — CHILLED WATER COILS (cont)

SIZE 100 — 5 ROW

EWT (F)	GPM	PD (ft)		CFM								
				1000			700			500		
				Entering Air Temperature — EDB/EWB (F)								
				85/71	80/67	75/63	85/71	80/67	75/63	85/71	80/67	75/63
42	2	1.6	TC	27.59	23.70	19.97	25.18	21.42	17.83	22.73	19.13	15.75
			SHC	18.73	17.41	15.97	15.45	14.27	12.98	12.91	11.82	10.64
			LDB	67.9	64.1	60.4	64.8	61.4	58.0	61.4	58.4	55.5
			LWB	63.2	59.7	56.3	60.5	57.4	54.3	57.3	54.6	52.1
	4	4.9	TC	39.66	33.28	27.22	34.96	29.10	23.63	29.93	24.79	20.02
			SHC	22.76	20.81	18.69	18.93	17.14	15.24	15.64	14.05	12.38
			LDB	64.2	61.0	57.9	60.3	57.6	55.1	56.4	54.3	52.4
			LWB	59.3	56.4	53.7	55.8	53.4	51.2	52.1	50.3	48.7
	6	9.8	TC	46.85	38.96	31.50	39.64	32.95	26.65	32.55	26.94	21.74
			SHC	25.39	22.98	20.38	20.75	18.69	16.49	16.73	14.95	13.12
			LDB	61.8	59.0	56.4	57.9	55.6	53.5	54.4	52.6	51.0
			LWB	56.9	54.4	52.1	53.3	51.3	49.5	50.0	48.6	47.2
8	16.1	TC	50.92	42.35	34.26	42.20	34.84	28.13	33.95	27.92	22.56	
		SHC	26.96	24.33	21.52	21.80	19.48	17.13	17.33	15.38	13.48	
		LDB	60.3	57.8	55.3	56.5	54.5	52.6	53.3	51.9	50.3	
		LWB	55.4	53.1	51.0	51.9	50.2	48.6	48.9	47.7	46.5	
45	2	1.6	TC	25.31	21.47	17.77	22.91	19.21	15.73	20.62	17.09	13.77
			SHC	18.02	16.66	15.18	14.70	13.49	12.20	12.17	11.07	9.88
			LDB	68.5	64.8	61.1	65.8	62.4	59.1	62.7	59.8	56.9
			LWB	63.9	60.4	57.1	61.6	58.4	55.4	58.8	56.1	53.6
	4	4.9	TC	35.90	29.59	23.77	31.68	25.89	20.43	27.20	22.08	17.33
			SHC	21.46	19.46	17.37	17.71	15.90	13.97	14.57	12.95	11.27
			LDB	65.4	62.2	59.1	61.9	59.2	56.7	58.4	56.3	54.4
			LWB	60.5	57.7	55.0	57.4	55.1	53.0	54.1	52.4	50.8
	6	9.8	TC	42.44	34.57	27.23	36.09	29.43	23.01	29.74	24.11	18.99
			SHC	23.76	21.29	18.69	19.36	17.27	14.99	15.57	13.77	11.95
			LDB	63.3	60.5	57.9	59.7	57.4	55.4	56.5	54.8	53.1
			LWB	58.4	56.0	53.7	55.2	53.2	51.5	52.2	50.8	49.5
8	16.1	TC	46.36	37.72	29.49	38.42	31.22	24.53	31.02	25.07	19.66	
		SHC	25.20	22.49	19.58	20.27	17.98	15.61	16.09	14.16	12.23	
		LDB	62.0	59.4	57.1	58.5	56.5	54.6	55.6	54.1	52.6	
		LWB	57.0	54.8	52.8	54.0	52.3	50.7	51.2	50.1	49.0	
48	2	1.6	TC	22.92	19.22	15.54	20.68	17.09	13.66	18.53	15.05	11.86
			SHC	17.28	15.92	15.54	13.98	12.77	11.45	11.47	10.34	9.17
			LDB	69.2	65.4	60.8	66.7	63.3	60.0	64.0	61.1	58.2
			LWB	64.6	61.1	57.9	62.6	59.4	56.5	60.2	57.5	55.0
	4	4.9	TC	32.12	25.97	20.35	28.25	22.64	17.33	24.39	19.32	14.61
			SHC	20.19	18.19	16.11	16.50	14.71	12.79	13.51	11.89	10.20
			LDB	66.5	63.4	60.3	63.5	60.8	58.3	60.3	58.3	56.3
			LWB	61.8	58.9	56.2	59.1	56.7	54.6	56.2	54.5	52.9
	6	9.8	TC	37.78	30.11	22.96	32.44	25.67	19.36	26.84	21.23	15.95
			SHC	22.11	19.65	17.07	17.99	15.82	13.56	14.43	12.62	10.72
			LDB	64.8	62.0	59.4	61.5	59.3	57.3	58.6	56.9	55.4
			LWB	59.9	57.5	55.3	57.0	55.2	53.5	54.4	53.1	51.9
8	16.1	TC	41.50	32.82	24.84	34.54	27.43	20.53	27.94	22.14	16.70	
		SHC	23.42	20.64	17.78	18.77	16.49	14.01	14.85	12.98	11.02	
		LDB	63.6	61.1	58.7	60.5	58.5	56.7	57.8	56.3	54.8	
		LWB	58.7	56.6	54.6	56.0	54.3	52.9	53.6	52.4	51.3	

LEGEND

- EDB — Entering Dry Bulb (F)
- EWB — Entering Wet Bulb (F)
- EWT — Entering Water Temperature (F)
- LDB — Leaving Dry Bulb (F)
- LWB — Leaving Wet Bulb (F)
- PD — Water Pressure Drop (ft)
- SHC — Sensible Capacity (1000 Btuh)
- TC — Total Capacity (1000 Btuh)

NOTE: Direct interpolation is permissible. Do not extrapolate.



40UV,UH COOLING CAPACITY — CHILLED WATER COILS (cont)

SIZE 100 — HIGH CAPACITY COIL

EWT (F)	GPM	PD (ft)		CFM								
				1000			700			500		
				Entering Air Temperature — EDB/EWB (F)								
				85/71	80/67	75/63	85/71	80/67	75/63	85/71	80/67	75/63
42	2	1.6	TC	29.85	25.82	21.87	27.19	23.27	19.47	24.48	20.71	17.13
			SHC	20.63	19.24	17.69	16.80	15.56	14.20	13.90	12.76	11.52
			LDB	66.1	62.4	58.8	63.1	59.7	56.5	59.6	56.7	53.9
			LWB	62.5	59.0	55.6	59.6	56.4	53.5	56.1	53.5	51.0
	4	4.9	TC	43.56	36.69	30.26	38.15	31.89	25.86	32.38	26.87	21.74
			SHC	25.18	23.07	20.83	20.68	18.78	16.69	16.90	15.20	13.41
			LDB	62.0	58.9	56.0	58.0	55.5	53.2	54.1	52.2	50.5
			LWB	58.0	55.2	52.5	54.1	51.9	49.9	50.2	48.6	47.2
	6	9.8	TC	51.87	43.23	35.09	43.65	36.25	29.22	35.29	29.24	23.57
			SHC	28.19	25.56	22.74	22.83	20.54	18.08	18.12	16.20	14.20
			LDB	59.2	56.6	54.2	55.2	53.2	51.4	51.9	50.4	49.0
			LWB	55.1	52.8	50.7	51.1	49.4	48.0	47.8	46.6	45.7
8	16.1	TC	56.99	47.35	38.22	46.42	38.44	30.90	36.73	30.18	24.29	
		SHC	30.16	27.20	24.02	23.97	21.46	18.80	18.74	16.61	14.52	
		LDB	57.4	55.1	53.0	53.7	52.0	50.4	50.7	49.6	48.5	
		LWB	53.2	51.2	49.4	49.5	48.1	47.0	46.6	45.8	45.0	
45	2	1.6	TC	27.46	23.42	19.56	24.85	20.97	17.24	22.28	18.56	15.02
			SHC	19.88	18.43	16.87	16.03	14.76	13.37	13.13	11.97	10.71
			LDB	66.8	63.1	59.6	64.1	60.7	57.5	61.0	58.1	55.4
			LWB	63.2	59.8	56.5	60.7	57.6	54.6	57.7	55.0	52.6
	4	4.9	TC	39.50	32.87	26.53	34.65	28.40	22.62	29.45	24.01	18.92
			SHC	23.78	21.69	19.40	19.39	17.44	15.40	15.75	14.04	12.24
			LDB	63.3	60.2	57.3	59.7	57.2	54.9	56.2	54.3	52.6
			LWB	59.4	56.6	53.9	55.9	53.8	51.8	52.4	50.9	49.6
	6	9.8	TC	46.99	38.41	30.54	39.75	32.29	25.41	32.29	26.10	20.51
			SHC	26.40	23.71	20.94	21.29	18.94	16.51	16.87	14.88	12.89
			LDB	60.9	58.3	55.9	57.2	55.3	53.4	54.1	52.8	51.4
			LWB	56.8	54.6	52.4	53.3	51.7	50.2	50.2	49.2	48.3
8	16.1	TC	51.76	42.09	33.12	42.37	34.41	26.91	33.50	27.11	21.23	
		SHC	28.15	25.12	21.95	22.32	19.79	17.12	17.36	15.30	13.19	
		LDB	59.3	57.0	54.9	55.8	54.1	52.6	53.2	52.0	50.9	
		LWB	55.1	53.2	51.4	51.8	50.5	49.3	49.3	48.4	47.7	
48	2	1.6	TC	25.05	21.09	17.67	22.51	18.68	15.05	20.07	16.41	12.97
			SHC	19.15	17.67	17.67	15.28	13.98	12.58	12.38	11.20	9.94
			LDB	67.5	63.8	58.8	65.0	61.7	58.6	62.4	59.5	56.8
			LWB	63.9	60.5	57.1	61.7	58.7	55.8	59.1	56.6	54.2
	4	4.9	TC	35.52	28.99	22.79	31.02	24.92	19.28	26.45	21.08	16.01
			SHC	22.45	20.32	18.02	18.10	16.16	14.13	14.61	12.90	11.09
			LDB	64.5	61.4	58.5	61.4	58.9	56.5	58.3	56.4	54.7
			LWB	60.7	57.9	55.3	57.7	55.6	53.6	54.7	53.2	51.9
	6	9.8	TC	42.02	33.71	25.94	35.64	28.31	21.48	29.10	23.02	17.39
			SHC	24.64	21.99	19.18	19.75	17.40	14.96	15.61	13.65	11.62
			LDB	62.5	59.9	57.5	59.2	57.3	55.5	56.5	55.0	53.7
			LWB	58.5	56.3	54.2	55.4	53.8	52.4	52.7	51.7	50.8
8	16.1	TC	46.29	36.81	27.97	38.23	30.20	22.75	30.34	24.00	18.10	
		SHC	26.15	23.12	19.95	20.71	18.12	15.45	16.09	14.03	11.91	
		LDB	61.1	58.9	56.8	57.9	56.3	54.8	55.6	54.3	53.2	
		LWB	57.1	55.2	53.4	54.1	52.8	51.7	51.8	50.9	50.2	

LEGEND

- EDB — Entering Dry Bulb (F)
- EWB — Entering Wet Bulb (F)
- EWT — Entering Water Temperature (F)
- LDB — Leaving Dry Bulb (F)
- LWB — Leaving Wet Bulb (F)
- PD — Water Pressure Drop (ft)
- SHC — Sensible Capacity (1000 Btuh)
- TC — Total Capacity (1000 Btuh)

NOTE: Direct interpolation is permissible. Do not extrapolate.

Performance data (cont)



40UV,UH COOLING CAPACITY — CHILLED WATER COILS (cont)

SIZE 125 — 3 ROW

EWT (F)	GPM	PD (ft)		CFM								
				1250			875			625		
				Entering Air Temperature — EDB/EWB (F)								
				85/71	80/67	75/63	85/71	80/67	75/63	85/71	80/67	75/63
42	6	7.2	TC	44.43	36.85	29.71	38.74	32.25	26.00	33.09	27.41	22.19
			SHC	27.83	25.21	22.41	23.25	21.02	18.58	19.34	17.35	15.31
			LDB	64.6	61.6	58.6	60.7	58.0	55.6	56.7	54.6	52.6
			LWB	60.7	57.8	55.0	57.8	55.1	52.8	54.7	52.5	50.5
	8	11.9	TC	48.74	40.48	32.75	41.72	34.57	27.97	34.87	28.90	23.21
			SHC	29.62	26.78	23.77	24.57	22.08	19.50	20.17	18.06	15.80
			LDB	63.3	60.4	57.6	59.3	56.9	54.6	55.5	53.6	51.9
			LWB	59.5	56.7	54.1	56.6	54.2	51.9	53.6	51.6	49.9
	10	17.6	TC	51.51	42.86	34.64	43.54	36.14	29.10	36.16	29.85	23.97
			SHC	30.81	27.84	24.64	25.39	22.81	20.04	20.78	18.52	16.17
			LDB	62.5	59.6	57.0	58.5	56.2	54.1	54.6	52.9	51.3
			LWB	58.8	56.1	53.5	55.8	53.5	51.4	52.9	51.0	49.4
12	24.5	TC	53.63	44.44	36.02	44.89	37.06	29.98	36.85	30.43	24.52	
		SHC	31.75	28.56	25.28	26.02	23.25	20.46	21.11	18.80	16.45	
		LDB	61.8	59.1	56.5	57.8	55.7	53.6	54.1	52.5	50.9	
		LWB	58.2	55.6	53.1	55.3	53.1	51.0	52.4	50.7	49.0	
45	6	7.2	TC	40.01	32.55	25.64	35.15	28.70	22.35	30.13	24.50	19.23
			SHC	26.06	23.42	20.64	21.73	19.47	16.94	18.01	16.02	13.93
			LDB	65.9	62.9	59.9	62.3	59.7	57.3	58.6	56.6	54.6
			LWB	61.8	58.9	56.1	59.2	56.6	54.3	56.4	54.3	52.4
	8	11.9	TC	44.22	35.97	28.02	37.88	30.81	24.25	31.87	25.83	20.27
			SHC	27.74	24.84	21.67	22.88	20.38	17.79	18.78	16.62	14.40
			LDB	64.7	61.8	59.1	61.1	58.7	56.4	57.5	55.7	53.9
			LWB	60.7	58.0	55.5	58.1	55.7	53.5	55.4	53.5	51.7
	10	17.6	TC	46.91	38.29	29.94	39.65	32.25	25.40	32.93	26.68	20.94
			SHC	28.85	25.82	22.51	23.65	21.02	18.31	19.26	17.01	14.71
			LDB	63.9	61.1	58.5	60.3	58.0	55.9	56.8	55.1	53.5
			LWB	60.0	57.4	54.9	57.4	55.1	53.0	54.8	53.0	51.3
12	24.5	TC	48.66	39.72	31.17	40.87	33.12	26.09	33.71	27.29	21.42	
		SHC	29.59	26.45	23.06	24.19	21.42	18.63	19.62	17.29	14.94	
		LDB	63.4	60.7	58.1	59.7	57.6	55.5	56.3	54.7	53.1	
		LWB	59.6	57.0	54.6	56.9	54.8	52.7	54.3	52.6	51.0	
48	6	7.2	TC	35.39	28.20	21.54	31.53	24.85	18.68	27.03	21.50	16.07
			SHC	24.29	21.67	18.93	20.26	17.86	15.36	16.69	14.71	12.52
			LDB	67.2	64.1	61.1	63.8	61.3	58.9	60.6	58.5	56.7
			LWB	63.0	60.1	57.3	60.5	58.1	55.8	58.1	56.0	54.3
	8	11.9	TC	39.49	31.01	23.39	34.05	27.04	20.17	28.65	22.75	17.09
			SHC	25.86	22.79	19.70	21.28	18.76	15.99	17.38	15.25	12.97
			LDB	66.1	63.3	60.6	62.8	60.4	58.3	59.6	57.7	56.0
			LWB	61.9	59.3	56.8	59.6	57.3	55.2	57.2	55.3	53.7
	10	17.6	TC	41.95	33.23	24.76	35.70	28.30	21.22	29.73	23.59	17.79
			SHC	26.83	23.70	20.27	21.96	19.30	16.45	17.84	15.62	13.28
			LDB	65.4	62.7	60.2	62.0	59.8	57.8	58.9	57.2	55.6
			LWB	61.3	58.7	56.4	58.9	56.8	54.8	56.6	54.8	53.2
12	24.5	TC	43.78	34.86	25.83	36.77	29.28	22.09	30.37	24.11	18.19	
		SHC	27.56	24.37	20.72	22.41	19.72	16.82	18.12	15.85	13.46	
		LDB	64.8	62.2	59.8	61.6	59.4	57.4	58.5	56.8	55.3	
		LWB	60.8	58.3	56.1	58.5	56.4	54.4	56.3	54.5	53.0	

LEGEND

- EDB — Entering Dry Bulb (F)
- EWB — Entering Wet Bulb (F)
- EWT — Entering Water Temperature (F)
- LDB — Leaving Dry Bulb (F)
- LWB — Leaving Wet Bulb (F)
- PD — Water Pressure Drop (ft)
- SHC — Sensible Capacity (1000 Btuh)
- TC — Total Capacity (1000 Btuh)

NOTE: Direct interpolation is permissible. Do not extrapolate.



40UV,UH COOLING CAPACITY — CHILLED WATER COILS (cont)

SIZE 125 — 4 ROW

EWT (F)	GPM	PD (ft)		CFM								
				1250			875			625		
				Entering Air Temperature — EDB/EWB (F)								
				85/71	80/67	75/63	85/71	80/67	75/63	85/71	80/67	75/63
42	6	5.8	TC	48.56	40.34	32.62	42.19	35.09	28.34	35.62	29.52	23.88
			SHC	28.81	26.12	23.25	23.97	21.65	19.15	19.73	17.71	15.60
			LDB	63.9	60.9	58.0	59.9	57.4	55.0	56.1	54.1	52.2
			LWB	59.6	56.8	54.1	56.4	54.0	51.7	53.2	51.2	49.4
	8	9.5	TC	53.63	44.68	36.02	45.47	37.69	30.48	37.68	31.11	25.12
			SHC	30.83	27.92	24.70	25.36	22.78	20.10	20.65	18.43	16.17
			LDB	62.4	59.6	56.9	58.5	56.2	54.0	54.8	53.0	51.3
			LWB	58.2	55.5	53.1	55.0	52.8	50.8	51.9	50.2	48.6
	10	14.1	TC	56.85	47.28	38.25	47.57	39.43	31.77	38.88	32.10	25.89
			SHC	32.16	29.02	25.68	26.28	23.56	20.69	21.20	18.89	16.54
			LDB	61.5	58.8	56.2	57.5	55.4	53.4	54.0	52.4	50.8
			LWB	57.3	54.8	52.4	54.2	52.1	50.2	51.2	49.6	48.1
12	19.6	TC	59.20	49.03	39.81	49.00	40.47	32.49	39.64	32.69	26.35	
		SHC	33.15	29.79	26.37	26.91	24.03	21.02	21.55	19.16	16.75	
		LDB	60.7	58.2	55.7	56.9	54.9	53.0	53.5	52.0	50.5	
		LWB	56.7	54.3	51.9	53.6	51.6	49.9	50.7	49.2	47.8	
45	6	5.8	TC	43.73	35.70	28.23	38.42	31.13	24.43	32.47	26.41	20.70
			SHC	26.97	24.27	21.43	22.44	19.99	17.46	18.39	16.34	14.19
			LDB	65.3	62.2	59.3	61.5	59.1	56.7	58.1	56.1	54.2
			LWB	60.9	58.1	55.4	57.9	55.6	53.4	55.0	53.1	51.4
	8	9.5	TC	48.66	39.57	30.94	41.33	33.61	26.38	34.31	27.91	21.90
			SHC	28.85	25.81	22.54	23.62	21.02	18.29	19.17	16.99	14.71
			LDB	63.9	61.1	58.5	60.3	58.0	55.9	57.0	55.1	53.5
			LWB	59.6	57.0	54.6	56.7	54.6	52.6	54.0	52.2	50.7
	10	14.1	TC	51.77	42.10	32.92	43.31	35.24	27.65	35.54	28.80	22.60
			SHC	30.08	26.84	23.37	24.44	21.71	18.84	19.70	17.38	15.02
			LDB	63.0	60.4	57.9	59.5	57.3	55.3	56.2	54.6	53.0
			LWB	58.7	56.3	54.0	55.9	53.9	52.0	53.2	51.7	50.2
12	19.6	TC	53.92	43.84	34.51	44.61	36.29	28.48	36.24	29.36	22.96	
		SHC	30.95	27.56	24.05	24.99	22.17	19.21	20.01	17.63	15.19	
		LDB	62.4	59.8	57.4	58.9	56.8	54.9	55.7	54.2	52.8	
		LWB	58.2	55.8	53.6	55.4	53.4	51.7	52.8	51.3	50.0	
48	6	5.8	TC	38.92	31.12	23.89	34.31	27.14	20.54	29.26	23.23	17.35
			SHC	25.20	22.52	19.70	20.85	18.40	15.87	17.08	15.02	12.77
			LDB	66.6	63.5	60.6	63.2	60.8	58.4	60.0	58.0	56.3
			LWB	62.1	59.3	56.6	59.5	57.2	55.1	56.9	55.0	53.5
	8	9.5	TC	43.46	34.37	25.92	37.16	29.49	22.09	30.96	24.58	18.47
			SHC	26.87	23.76	20.50	21.94	19.33	16.49	17.77	15.57	13.23
			LDB	65.3	62.6	60.0	62.1	59.8	57.8	59.0	57.2	55.6
			LWB	60.9	58.4	56.1	58.4	56.3	54.4	55.9	54.2	52.8
	10	14.1	TC	46.32	36.78	27.53	39.05	30.92	23.27	32.07	25.33	19.13
			SHC	27.95	24.69	21.15	22.69	19.91	16.98	18.22	15.89	13.51
			LDB	64.6	61.9	59.5	61.3	59.2	57.3	58.3	56.8	55.2
			LWB	60.2	57.8	55.6	57.6	55.7	53.9	55.3	53.8	52.4
12	19.6	TC	48.28	38.48	28.81	40.26	31.96	24.02	32.81	25.86	19.57	
		SHC	28.70	25.37	21.67	23.18	20.33	17.29	18.53	16.11	13.70	
		LDB	64.0	61.4	59.1	60.8	58.7	56.9	57.9	56.4	55.0	
		LWB	59.7	57.3	55.2	57.2	55.3	53.6	54.8	53.5	52.1	

LEGEND

- EDB — Entering Dry Bulb (F)
- EWB — Entering Wet Bulb (F)
- EWT — Entering Water Temperature (F)
- LDB — Leaving Dry Bulb (F)
- LWB — Leaving Wet Bulb (F)
- PD — Water Pressure Drop (ft)
- SHC — Sensible Capacity (1000 Btuh)
- TC — Total Capacity (1000 Btuh)

NOTE: Direct interpolation is permissible. Do not extrapolate.

Performance data (cont)



40UV,UH COOLING CAPACITY — CHILLED WATER COILS (cont)

SIZE 125 — 5 ROW

EWT (F)	GPM	PD (ft)		CFM								
				1250			875			625		
				Entering Air Temperature — EDB/EWB (F)								
				85/71	80/67	75/63	85/71	80/67	75/63	85/71	80/67	75/63
42	6	3.3	TC	51.43	42.86	34.77	44.71	37.19	29.98	37.68	31.17	25.18
			SHC	29.35	26.67	23.79	24.35	22.00	19.43	19.98	17.90	15.75
			LDB	63.5	60.5	57.6	59.5	57.0	54.7	55.8	53.8	52.0
			LWB	58.8	56.1	53.5	55.4	53.1	51.0	51.9	50.2	48.6
	8	5.5	TC	57.26	47.64	38.39	48.45	40.16	32.33	39.80	32.78	26.48
			SHC	31.57	28.56	25.27	25.87	23.24	20.43	20.89	18.60	16.33
			LDB	61.9	59.1	56.5	58.0	55.7	53.6	54.4	52.8	51.1
			LWB	57.2	54.7	52.4	53.8	51.8	49.9	50.6	49.1	47.7
	10	8.2	TC	61.05	50.78	41.08	50.75	41.94	33.81	40.98	33.84	27.27
			SHC	33.06	29.84	26.40	26.83	24.00	21.08	21.41	19.07	16.69
			LDB	60.8	58.2	55.7	57.0	54.9	53.0	53.7	52.1	50.6
			LWB	56.2	53.8	51.5	52.8	51.0	49.2	49.8	48.4	47.2
12	11.5	TC	63.80	52.94	42.81	52.29	43.24	34.84	41.84	34.60	27.72	
		SHC	34.18	30.75	27.14	27.49	24.56	21.54	21.79	19.41	16.89	
		LDB	60.0	57.5	55.1	56.3	54.3	52.5	53.1	51.6	50.3	
		LWB	55.4	53.1	51.0	52.1	50.4	48.8	49.3	47.9	46.9	
45	6	3.3	TC	46.39	38.01	30.18	40.66	33.00	25.90	34.31	27.91	21.82
			SHC	27.52	24.82	21.97	22.78	20.32	17.75	18.60	16.53	14.32
			LDB	64.9	61.8	58.9	61.2	58.8	56.4	57.8	55.8	54.0
			LWB	60.2	57.4	54.8	57.0	54.8	52.8	54.0	52.2	50.7
	8	5.5	TC	51.96	42.26	33.16	43.97	35.89	28.06	36.33	29.47	23.04
			SHC	29.55	26.44	23.14	24.06	21.47	18.63	19.42	17.18	14.83
			LDB	63.4	60.7	58.1	59.9	57.6	55.5	56.6	54.9	53.3
			LWB	58.7	56.2	54.0	55.7	53.6	51.9	52.8	51.3	50.0
	10	8.2	TC	55.49	45.29	35.41	46.21	37.49	29.53	37.55	30.43	23.86
			SHC	30.88	27.62	24.04	24.95	22.12	19.24	19.93	17.58	15.18
			LDB	62.4	59.8	57.4	58.9	56.9	54.9	55.8	54.3	52.8
			LWB	57.7	55.4	53.3	54.7	52.9	51.2	52.0	50.7	49.4
12	11.5	TC	57.95	47.14	37.08	47.69	38.64	30.39	38.35	31.01	24.25	
		SHC	31.84	28.36	24.73	25.56	22.60	19.61	20.27	17.83	15.35	
		LDB	61.7	59.3	56.9	58.3	56.4	54.5	55.3	53.9	52.5	
		LWB	57.0	54.8	52.8	54.1	52.4	50.8	51.5	50.3	49.2	
48	6	3.3	TC	41.43	33.23	25.62	36.25	28.79	21.86	30.91	24.49	18.33
			SHC	25.78	23.07	20.23	21.14	18.70	16.16	17.27	15.16	12.90
			LDB	66.1	63.1	60.2	62.9	60.5	58.1	59.7	57.8	56.1
			LWB	61.4	58.7	56.1	58.7	56.6	54.5	55.9	54.3	52.9
	8	5.5	TC	46.32	36.78	27.93	39.63	31.38	23.58	32.81	25.92	19.50
			SHC	27.49	24.36	21.10	22.39	19.69	16.83	18.00	15.73	13.37
			LDB	64.9	62.2	59.6	61.6	59.4	57.4	58.7	57.0	55.4
			LWB	60.2	57.8	55.5	57.4	55.5	53.8	54.8	53.4	52.2
	10	8.2	TC	49.86	39.41	29.65	41.63	33.03	24.74	33.93	26.74	20.24
			SHC	28.77	25.35	21.77	23.15	20.33	17.29	18.45	16.06	13.67
			LDB	64.0	61.5	59.1	60.8	58.8	56.9	58.0	56.5	55.0
			LWB	59.2	57.0	55.0	56.6	54.8	53.3	54.2	52.9	51.7
12	11.5	TC	52.06	41.40	30.94	43.02	34.15	25.63	34.56	27.34	20.67	
		SHC	29.58	26.10	22.27	23.69	20.77	17.64	18.70	16.30	13.85	
		LDB	63.4	60.9	58.7	60.2	58.3	56.6	57.6	56.2	54.7	
		LWB	58.7	56.5	54.6	56.0	54.3	52.9	53.8	52.6	51.5	

LEGEND

- EDB — Entering Dry Bulb (F)
- EWB — Entering Wet Bulb (F)
- EWT — Entering Water Temperature (F)
- LDB — Leaving Dry Bulb (F)
- LWB — Leaving Wet Bulb (F)
- PD — Water Pressure Drop (ft)
- SHC — Sensible Capacity (1000 Btuh)
- TC — Total Capacity (1000 Btuh)

NOTE: Direct interpolation is permissible. Do not extrapolate.



40UV,UH COOLING CAPACITY — CHILLED WATER COILS (cont)

SIZE 125 — HIGH CAPACITY COIL

EWT (F)	GPM	PD (ft)		CFM								
				1250			875			625		
				Entering Air Temperature — EDB/EWB (F)								
				85/71	80/67	75/63	85/71	80/67	75/63	85/71	80/67	75/63
42	6	3.3	TC	56.63	47.45	38.82	49.11	40.80	33.07	40.88	33.88	27.37
			SHC	32.63	29.76	26.70	26.82	24.21	21.47	21.69	19.46	17.13
			LDB	61.1	58.2	55.5	57.0	54.7	52.6	53.3	51.5	49.9
			LWB	57.4	54.7	52.2	53.5	51.5	49.6	49.9	48.4	47.1
	8	5.5	TC	63.65	52.94	42.90	53.45	44.18	35.64	43.22	35.83	28.77
			SHC	35.27	31.92	28.36	28.57	25.61	22.57	22.69	20.31	17.75
			LDB	59.2	56.6	54.3	55.1	53.2	51.4	51.8	50.3	49.0
			LWB	55.4	53.1	51.0	51.6	49.9	48.4	48.4	47.1	46.1
	10	8.2	TC	68.39	56.87	45.77	56.12	46.50	37.53	44.75	36.90	29.66
			SHC	37.13	33.52	29.56	29.69	26.61	23.39	23.36	20.78	18.15
			LDB	57.8	55.5	53.4	54.0	52.2	50.6	50.8	49.6	48.4
			LWB	54.0	51.9	50.1	50.4	48.9	47.5	47.4	46.4	45.5
12	11.5	TC	71.70	59.49	48.00	57.94	47.91	38.52	45.47	37.55	30.19	
		SHC	38.47	34.61	30.51	30.47	27.22	23.83	23.68	21.08	18.39	
		LDB	56.9	54.7	52.7	53.2	51.5	50.1	50.3	49.2	48.1	
		LWB	53.0	51.1	49.3	49.6	48.2	47.0	46.9	45.9	45.2	
45	6	3.3	TC	51.33	42.26	33.78	44.51	36.34	28.69	37.37	30.39	23.83
			SHC	30.71	27.80	24.71	25.04	22.42	19.67	20.25	17.99	15.61
			LDB	62.5	59.7	56.9	58.8	56.6	54.4	55.4	53.7	52.2
			LWB	58.8	56.2	53.8	55.4	53.4	51.6	52.1	50.7	49.5
	8	5.5	TC	57.69	47.07	37.22	48.68	39.57	31.07	39.60	32.15	25.17
			SHC	33.02	29.62	26.06	26.65	23.71	20.64	21.16	18.72	16.18
			LDB	60.8	58.3	55.9	57.2	55.2	53.4	54.0	52.6	51.3
			LWB	57.1	54.8	52.7	53.7	52.0	50.5	50.7	49.6	48.6
	10	8.2	TC	62.12	50.52	39.70	51.22	41.62	32.42	40.78	33.07	25.89
			SHC	34.68	30.96	27.05	27.66	24.54	21.20	21.65	19.11	16.49
			LDB	59.6	57.4	55.2	56.1	54.3	52.8	53.3	52.0	50.9
			LWB	55.9	53.8	52.0	52.6	51.1	49.9	50.0	49.0	48.1
12	11.5	TC	65.17	53.17	41.57	52.90	42.92	33.64	41.71	33.72	26.40	
		SHC	35.86	32.01	27.81	28.34	25.08	21.71	22.04	19.39	16.70	
		LDB	58.8	56.6	54.7	55.4	53.8	52.3	52.7	51.6	50.6	
		LWB	55.0	53.0	51.4	51.9	50.5	49.3	49.4	48.5	47.8	
48	6	3.3	TC	45.98	37.09	28.92	39.86	31.80	24.38	33.63	26.63	20.16
			SHC	28.85	25.91	22.86	23.32	20.69	17.97	18.79	16.49	14.12
			LDB	63.9	61.0	58.3	60.6	58.4	56.2	57.5	55.9	54.3
			LWB	60.3	57.7	55.2	57.3	55.3	53.5	54.4	53.0	51.8
	8	5.5	TC	51.48	41.17	31.55	43.71	34.67	26.24	35.73	28.30	21.29
			SHC	30.77	27.40	23.85	24.74	21.78	18.69	19.60	17.15	14.58
			LDB	62.5	60.0	57.5	59.1	57.2	55.5	56.3	54.9	53.7
			LWB	58.8	56.5	54.4	55.8	54.1	52.6	53.1	52.0	51.1
	10	8.2	TC	55.59	44.13	33.55	46.12	36.56	27.48	36.93	29.20	22.03
			SHC	32.24	28.50	24.62	25.65	22.51	19.18	20.07	17.51	14.87
			LDB	61.4	59.1	57.0	58.2	56.5	55.0	55.6	54.4	53.2
			LWB	57.7	55.7	53.8	54.8	53.3	52.1	52.4	51.4	50.6
12	11.5	TC	58.59	46.35	35.05	47.73	37.75	28.41	37.69	29.79	22.54	
		SHC	33.35	29.34	25.20	26.27	22.98	19.55	20.38	17.75	15.08	
		LDB	60.6	58.5	56.6	57.5	56.0	54.6	55.2	54.0	52.9	
		LWB	56.9	55.1	53.4	54.1	52.8	51.7	51.9	51.1	50.3	

LEGEND

- EDB** — Entering Dry Bulb (F)
- EWB** — Entering Wet Bulb (F)
- EWT** — Entering Water Temperature (F)
- LDB** — Leaving Dry Bulb (F)
- LWB** — Leaving Wet Bulb (F)
- PD** — Water Pressure Drop (ft)
- SHC** — Sensible Capacity (1000 Btuh)
- TC** — Total Capacity (1000 Btuh)

NOTE: Direct interpolation is permissible. Do not extrapolate.

Performance data (cont)



40UV,UH COOLING CAPACITY — CHILLED WATER COILS (cont)

SIZE 150 — 3 ROW

EWT (F)	GPM	PD (ft)		CFM								
				1500			1050			750		
				Entering Air Temperature — EDB/EWB (F)								
				85/71	80/67	75/63	85/71	80/67	75/63	85/71	80/67	75/63
42	8	8.3	TC	54.58	45.55	36.72	47.23	39.29	31.89	40.14	33.17	26.84
			SHC	33.45	30.39	26.97	27.88	25.17	22.32	23.13	20.70	18.24
			LDB	64.6	61.5	58.6	60.7	58.1	55.6	56.8	54.8	52.8
			LWB	60.4	57.4	54.7	57.5	54.9	52.5	54.5	52.4	50.4
	10	12.3	TC	58.49	48.58	39.44	49.73	41.33	33.44	41.70	34.43	27.74
			SHC	35.08	31.70	28.19	28.98	26.10	23.04	23.86	21.29	18.68
			LDB	63.6	60.7	57.8	59.8	57.3	54.9	55.9	54.0	52.2
			LWB	59.5	56.7	54.1	56.7	54.2	51.9	53.7	51.8	49.9
	12	17.1	TC	61.13	50.84	41.01	51.67	42.82	34.51	42.74	35.30	28.45
			SHC	36.21	32.70	28.90	29.85	26.79	23.55	24.35	21.71	19.02
			LDB	62.9	60.1	57.4	59.0	56.7	54.5	55.3	53.5	51.8
			LWB	59.0	56.2	53.7	56.0	53.7	51.6	53.2	51.3	49.5
	14	22.7	TC	63.16	52.36	42.36	52.87	43.82	35.31	43.55	35.95	28.94
			SHC	37.09	33.38	29.52	30.40	27.25	23.93	24.73	22.03	19.26
			LDB	62.4	59.6	57.0	58.5	56.3	54.2	54.8	53.1	51.5
			LWB	58.5	55.9	53.3	55.6	53.3	51.3	52.8	51.0	49.3
45	8	8.3	TC	49.50	40.13	31.49	43.12	35.11	27.34	36.54	29.62	23.33
			SHC	31.41	28.12	24.70	26.13	23.34	20.28	21.53	19.08	16.61
			LDB	65.9	62.9	59.9	62.2	59.7	57.3	58.8	56.7	54.7
			LWB	61.5	58.7	56.0	58.9	56.4	54.1	56.2	54.2	52.2
	10	12.3	TC	52.87	43.32	33.63	45.45	36.83	29.10	37.96	30.87	24.24
			SHC	32.76	29.45	25.62	27.11	24.08	21.06	22.15	19.65	17.03
			LDB	65.0	62.0	59.4	61.4	59.0	56.7	58.0	56.0	54.2
			LWB	60.8	58.0	55.5	58.1	55.8	53.5	55.5	53.6	51.8
	12	17.1	TC	55.44	45.27	35.40	46.95	38.12	30.03	38.96	31.69	24.84
			SHC	33.81	30.27	26.39	27.75	24.65	21.48	22.60	20.02	17.31
			LDB	64.4	61.5	58.9	60.8	58.5	56.3	57.4	55.6	53.9
			LWB	60.2	57.5	55.0	57.6	55.3	53.2	55.1	53.2	51.4
	14	22.7	TC	57.37	46.65	36.86	48.10	39.19	30.73	39.80	32.26	25.31
			SHC	34.61	30.87	27.03	28.26	25.13	21.79	22.98	20.28	17.52
			LDB	63.9	61.2	58.5	60.4	58.1	56.0	57.0	55.3	53.6
			LWB	59.8	57.2	54.7	57.2	55.0	52.9	54.6	52.9	51.2
48	8	8.3	TC	43.98	34.78	26.43	38.48	30.56	22.87	32.87	26.09	19.54
			SHC	29.28	25.98	22.60	24.25	21.43	18.36	19.96	17.55	14.94
			LDB	67.1	64.2	61.2	63.9	61.3	59.0	60.7	58.6	56.8
			LWB	62.6	59.9	57.2	60.3	57.9	55.7	57.9	55.9	54.1
	10	12.3	TC	47.39	37.49	28.07	40.72	32.45	24.20	34.26	27.20	20.44
			SHC	30.59	27.05	23.27	25.14	22.21	18.92	20.55	18.02	15.33
			LDB	66.4	63.5	60.8	63.1	60.7	58.5	59.9	58.0	56.3
			LWB	61.9	59.3	56.8	59.6	57.3	55.2	57.3	55.4	53.7
	12	17.1	TC	49.80	39.53	29.38	42.21	33.51	25.19	35.15	27.91	21.05
			SHC	31.53	27.88	23.82	25.75	22.66	19.34	20.93	18.33	15.60
			LDB	65.8	63.0	60.5	62.6	60.3	58.2	59.5	57.6	56.0
			LWB	61.4	58.8	56.5	59.1	56.9	54.9	56.9	55.0	53.4
	14	22.7	TC	51.35	40.95	30.52	43.40	34.46	25.99	35.92	28.41	21.43
			SHC	32.14	28.46	24.30	26.25	23.06	19.69	21.26	18.55	15.76
			LDB	65.4	62.6	60.2	62.1	59.9	57.9	59.1	57.4	55.8
			LWB	61.1	58.5	56.2	58.8	56.6	54.6	56.5	54.8	53.2

LEGEND

- EDB — Entering Dry Bulb (F)
- EWB — Entering Wet Bulb (F)
- EWT — Entering Water Temperature (F)
- LDB — Leaving Dry Bulb (F)
- LWB — Leaving Wet Bulb (F)
- PD — Water Pressure Drop (ft)
- SHC — Sensible Capacity (1000 Btuh)
- TC — Total Capacity (1000 Btuh)

NOTE: Direct interpolation is permissible. Do not extrapolate.



40UV,UH COOLING CAPACITY — CHILLED WATER COILS (cont)

SIZE 150 — 4 ROW

EWT (F)	GPM	PD (ft)		CFM								
				1500			1050			750		
				Entering Air Temperature — EDB/EWB (F)								
				85/71	80/67	75/63	85/71	80/67	75/63	85/71	80/67	75/63
42	8	7.4	TC	61.81	51.44	41.57	53.27	44.24	35.71	44.55	36.93	29.83
			SHC	36.49	33.10	29.43	30.18	27.21	24.05	24.65	22.11	19.45
			LDB	62.8	59.8	57.1	58.7	56.3	54.1	54.9	53.0	51.3
			LWB	58.8	56.1	53.5	55.5	53.2	51.1	52.3	50.4	48.8
	10	11.0	TC	66.41	55.28	44.73	56.20	46.62	37.71	46.32	38.33	30.93
			SHC	38.32	34.69	30.78	31.41	28.25	24.94	25.43	22.74	19.96
			LDB	61.6	58.8	56.2	57.6	55.4	53.3	54.0	52.3	50.7
			LWB	57.8	55.1	52.7	54.5	52.3	50.3	51.4	49.7	48.2
	12	15.2	TC	69.75	58.02	46.93	58.28	48.20	38.84	47.51	39.13	31.54
			SHC	39.69	35.85	31.74	32.31	28.95	25.45	25.97	23.11	20.25
			LDB	60.8	58.1	55.6	56.9	54.8	52.8	53.3	51.8	50.3
			LWB	57.0	54.5	52.2	53.7	51.8	49.9	50.7	49.3	47.8
	14	20.2	TC	72.32	59.92	48.56	59.68	49.42	39.83	48.40	39.95	32.13
			SHC	40.76	36.67	32.47	32.93	29.50	25.90	26.38	23.49	20.53
			LDB	60.2	57.6	55.2	56.3	54.3	52.4	52.8	51.4	50.0
			LWB	56.4	54.0	51.7	53.2	51.3	49.5	50.3	48.8	47.5
45	8	7.4	TC	55.87	45.61	35.93	48.39	39.39	30.84	40.57	33.00	25.96
			SHC	34.21	30.77	27.09	28.18	25.17	21.94	22.94	20.38	17.73
			LDB	64.1	61.2	58.5	60.5	58.1	55.9	57.0	55.1	53.4
			LWB	60.1	57.4	54.9	57.1	54.9	52.9	54.3	52.5	50.9
	10	11.0	TC	60.26	49.19	38.46	51.16	41.62	32.67	42.28	34.30	26.92
			SHC	35.89	32.19	28.13	29.30	26.10	22.72	23.66	20.94	18.15
			LDB	63.1	60.4	57.8	59.5	57.3	55.2	56.1	54.5	52.9
			LWB	59.2	56.6	54.3	56.2	54.1	52.2	53.4	51.8	50.3
	12	15.2	TC	63.51	51.66	40.40	52.95	43.07	33.93	43.41	35.19	27.55
			SHC	37.16	33.19	28.94	30.04	26.71	23.27	24.15	21.34	18.43
			LDB	62.3	59.8	57.4	58.8	56.7	54.7	55.6	54.0	52.5
			LWB	58.4	56.0	53.8	55.6	53.6	51.8	52.8	51.4	50.0
	14	20.2	TC	65.85	53.49	42.04	54.48	44.19	34.69	44.23	35.76	28.06
			SHC	38.10	33.95	29.63	30.68	27.19	23.60	24.51	21.58	18.66
			LDB	61.8	59.3	56.9	58.3	56.3	54.4	55.1	53.7	52.3
			LWB	57.9	55.6	53.4	55.1	53.2	51.5	52.4	51.1	49.7
48	8	7.4	TC	49.72	39.68	30.42	43.40	34.34	25.99	36.58	29.06	21.74
			SHC	31.94	28.49	24.89	26.24	23.14	19.95	21.31	18.74	15.94
			LDB	65.5	62.6	59.8	62.1	59.8	57.6	59.0	57.2	55.6
			LWB	61.4	58.8	56.2	58.8	56.6	54.6	56.2	54.4	53.0
	10	11.0	TC	53.87	42.60	32.31	46.01	36.52	27.45	38.19	30.22	22.70
			SHC	33.46	29.60	25.64	27.25	24.01	20.54	21.96	19.21	16.33
			LDB	64.6	62.0	59.4	61.3	59.1	57.1	58.2	56.6	55.1
			LWB	60.5	58.1	55.8	57.9	55.9	54.1	55.4	53.9	52.5
	12	15.2	TC	56.88	45.00	33.94	47.78	37.94	28.51	39.20	30.92	23.40
			SHC	34.59	30.53	26.29	27.94	24.58	20.97	22.37	19.50	16.63
			LDB	63.9	61.4	59.0	60.7	58.6	56.7	57.7	56.2	54.7
			LWB	59.9	57.6	55.4	57.3	55.4	53.7	54.9	53.5	52.2
	14	20.2	TC	58.96	46.86	35.09	49.04	38.94	29.25	39.97	31.50	23.84
			SHC	35.38	31.26	26.75	28.44	24.99	21.28	22.69	19.75	16.82
			LDB	63.4	60.9	58.7	60.2	58.2	56.5	57.3	55.9	54.5
			LWB	59.4	57.1	55.1	56.9	55.1	53.5	54.6	53.2	52.0

LEGEND

- EDB — Entering Dry Bulb (F)
- EWB — Entering Wet Bulb (F)
- EWT — Entering Water Temperature (F)
- LDB — Leaving Dry Bulb (F)
- LWB — Leaving Wet Bulb (F)
- PD — Water Pressure Drop (ft)
- SHC — Sensible Capacity (1000 Btuh)
- TC — Total Capacity (1000 Btuh)

NOTE: Direct interpolation is permissible. Do not extrapolate.

Performance data (cont)



40UV,UH COOLING CAPACITY — CHILLED WATER COILS (cont)

SIZE 150 — 5 ROW

EWT (F)	GPM	PD (ft)		CFM								
				1500			1050			750		
				Entering Air Temperature — EDB/EWB (F)								
				85/71	80/67	75/63	85/71	80/67	75/63	85/71	80/67	75/63
42	8	6.5	TC	66.07	55.04	44.57	56.65	47.07	37.99	47.04	38.90	31.42
			SHC	37.27	33.82	30.09	30.65	27.64	24.41	24.87	22.26	19.58
			LDB	62.3	59.4	56.7	58.3	55.9	53.7	54.7	52.9	51.1
			LWB	57.8	55.2	52.8	54.3	52.2	50.2	51.0	49.4	47.9
	10	9.6	TC	71.24	59.26	47.94	59.84	49.60	40.06	48.77	40.31	32.53
			SHC	39.24	35.50	31.48	31.95	28.70	25.30	25.61	22.87	20.07
			LDB	61.1	58.4	55.8	57.2	55.0	53.0	53.8	52.1	50.5
			LWB	56.6	54.2	51.9	53.2	51.2	49.4	50.1	48.6	47.3
	12	13.4	TC	74.90	62.13	50.45	61.98	51.31	41.45	49.98	41.30	33.16
			SHC	40.69	36.67	32.54	32.85	29.43	25.90	26.15	23.31	20.35
			LDB	60.2	57.6	55.2	56.4	54.4	52.4	53.1	51.6	50.2
			LWB	55.8	53.5	51.2	52.4	50.6	48.9	49.4	48.1	46.9
14	17.7	TC	77.69	64.35	52.06	63.54	52.55	42.34	50.92	41.89	33.75	
		SHC	41.81	37.59	33.22	33.51	29.97	26.30	26.56	23.57	20.62	
		LDB	59.5	57.1	54.7	55.8	53.9	52.1	52.6	51.3	49.9	
		LWB	55.1	52.9	50.8	51.8	50.1	48.6	48.9	47.7	46.6	
45	8	6.5	TC	59.69	48.83	38.69	51.49	41.91	32.89	42.91	34.84	27.34
			SHC	34.91	31.43	27.75	28.62	25.55	22.29	23.16	20.54	17.83
			LDB	63.7	60.8	58.1	60.1	57.7	55.6	56.8	55.0	53.3
			LWB	59.3	56.7	54.2	56.1	54.0	52.1	53.1	51.5	50.1
	10	9.6	TC	64.70	52.61	41.41	54.41	44.30	34.78	44.61	36.16	28.38
			SHC	36.75	32.87	28.82	29.76	26.51	23.07	23.86	21.09	18.26
			LDB	62.6	60.0	57.4	59.1	56.9	54.9	55.9	54.3	52.7
			LWB	58.1	55.8	53.6	55.1	53.2	51.4	52.2	50.8	49.6
	12	13.4	TC	68.13	55.48	43.49	56.54	45.85	36.11	45.72	37.07	28.98
			SHC	38.04	33.99	29.65	30.61	27.14	23.62	24.32	21.47	18.52
			LDB	61.8	59.3	56.9	58.3	56.4	54.4	55.3	53.8	52.4
			LWB	57.4	55.1	53.0	54.4	52.6	50.9	51.7	50.4	49.2
14	17.7	TC	70.57	57.41	45.16	58.00	47.05	36.93	46.53	37.61	29.49	
		SHC	38.99	34.76	30.33	31.20	27.63	23.96	24.66	21.70	18.74	
		LDB	61.2	58.8	56.5	57.8	55.9	54.1	54.9	53.5	52.2	
		LWB	56.8	54.6	52.6	53.8	52.2	50.6	51.2	50.1	49.0	
48	8	6.5	TC	53.27	42.70	32.87	46.18	36.61	27.75	38.71	30.67	23.05
			SHC	32.63	29.16	25.51	26.63	23.50	20.25	21.51	18.86	16.07
			LDB	65.1	62.2	59.4	61.8	59.5	57.4	58.8	57.0	55.4
			LWB	60.7	58.1	55.6	57.9	55.9	54.0	55.2	53.7	52.4
	10	9.6	TC	57.73	45.84	34.96	49.04	38.88	29.25	40.26	31.84	23.99
			SHC	34.20	30.31	26.30	27.69	24.37	20.84	22.11	19.33	16.45
			LDB	64.1	61.5	59.0	60.9	58.8	56.9	58.0	56.4	54.9
			LWB	59.7	57.4	55.1	56.9	55.1	53.5	54.4	53.1	51.9
	12	13.4	TC	61.11	48.44	36.59	50.85	40.46	30.33	41.27	32.60	24.68
			SHC	35.43	31.28	26.93	28.38	24.98	21.26	22.51	19.63	16.73
			LDB	63.4	60.9	58.6	60.3	58.2	56.5	57.6	56.1	54.6
			LWB	59.0	56.8	54.7	56.3	54.5	53.1	53.9	52.7	51.5
14	17.7	TC	63.44	50.38	37.86	52.33	41.45	31.14	42.01	33.17	25.08	
		SHC	36.28	32.02	27.42	28.95	25.37	21.59	22.80	19.86	16.89	
		LDB	62.9	60.5	58.3	59.8	57.9	56.2	57.2	55.8	54.4	
		LWB	58.4	56.3	54.4	55.8	54.2	52.8	53.5	52.4	51.3	

LEGEND

- EDB — Entering Dry Bulb (F)
- EWB — Entering Wet Bulb (F)
- EWT — Entering Water Temperature (F)
- LDB — Leaving Dry Bulb (F)
- LWB — Leaving Wet Bulb (F)
- PD — Water Pressure Drop (ft)
- SHC — Sensible Capacity (1000 Btuh)
- TC — Total Capacity (1000 Btuh)

NOTE: Direct interpolation is permissible. Do not extrapolate.



40UV,UH COOLING CAPACITY — CHILLED WATER COILS (cont)

SIZE 150 — HIGH CAPACITY COIL

EWT (F)	GPM	PD (ft)		CFM								
				1500			1050			750		
				Entering Air Temperature — EDB/EWB (F)								
				85/71	80/67	75/63	85/71	80/67	75/63	85/71	80/67	75/63
42	8	6.5	TC	73.01	61.08	49.83	62.30	51.76	41.91	51.22	42.40	34.17
			SHC	41.36	37.66	33.67	33.69	30.38	26.88	27.03	24.19	21.23
			LDB	59.8	57.0	54.5	55.7	53.5	51.6	52.0	50.5	49.1
			LWB	56.2	53.7	51.4	52.3	50.4	48.7	48.7	47.4	46.3
	10	9.6	TC	79.41	66.04	53.48	66.09	54.66	44.16	53.02	43.92	35.35
			SHC	43.81	39.63	35.17	35.24	31.59	27.85	27.81	24.86	21.76
			LDB	58.3	55.8	53.6	54.3	52.5	50.7	51.1	49.7	48.5
			LWB	54.7	52.5	50.4	50.9	49.3	47.8	47.7	46.6	45.7
	12	13.4	TC	83.90	69.70	56.31	68.44	56.65	45.81	54.26	44.71	36.09
			SHC	45.57	41.12	36.36	36.22	32.45	28.57	28.35	25.21	22.09
			LDB	57.2	54.9	52.8	53.5	51.7	50.1	50.4	49.3	48.1
			LWB	53.6	51.5	49.7	50.0	48.5	47.2	47.0	46.1	45.2
14	17.7	TC	87.20	72.40	58.20	70.21	58.13	46.92	55.18	45.38	36.46	
		SHC	46.91	42.24	37.16	36.98	33.09	29.06	28.76	25.51	22.26	
		LDB	56.4	54.2	52.3	52.8	51.2	49.7	49.9	48.9	47.9	
		LWB	52.7	50.8	49.2	49.3	47.9	46.7	46.5	45.7	45.0	
45	8	6.5	TC	66.17	54.45	43.38	56.55	46.12	36.39	46.71	37.85	29.67
			SHC	38.85	35.11	31.09	31.43	28.09	24.58	25.15	22.26	19.29
			LDB	61.3	58.6	56.0	57.6	55.5	53.6	54.3	52.9	51.5
			LWB	57.8	55.3	53.1	54.3	52.5	50.8	51.1	49.9	48.9
	10	9.6	TC	71.93	58.73	46.49	60.14	48.96	38.37	48.55	39.25	30.86
			SHC	40.96	36.74	32.32	32.83	29.23	25.40	25.90	22.84	19.79
			LDB	60.0	57.6	55.3	56.4	54.5	52.9	53.4	52.1	50.9
			LWB	56.5	54.3	52.3	53.1	51.5	50.1	50.2	49.2	48.2
	12	13.4	TC	76.21	61.99	48.82	62.53	50.81	39.87	49.76	40.11	31.54
			SHC	42.57	38.01	33.26	33.78	29.98	26.02	26.41	23.21	20.08
			LDB	59.0	56.8	54.7	55.6	53.9	52.3	52.8	51.7	50.5
			LWB	55.5	53.5	51.7	52.2	50.8	49.5	49.5	48.7	47.8
14	17.7	TC	79.31	64.67	50.69	64.20	52.11	40.72	50.39	40.91	31.90	
		SHC	43.77	39.07	34.02	34.46	30.52	26.38	26.68	23.55	20.24	
		LDB	58.3	56.2	54.3	55.0	53.4	52.0	52.5	51.3	50.3	
		LWB	54.7	52.8	51.2	51.6	50.3	49.2	49.2	48.3	47.6	
48	8	6.5	TC	59.24	47.76	37.09	50.77	40.46	30.92	42.14	33.33	25.20
			SHC	36.40	32.63	28.67	29.26	25.89	22.41	23.34	20.44	17.46
			LDB	62.8	60.1	57.5	59.5	57.4	55.5	56.5	55.1	53.7
			LWB	59.4	56.9	54.6	56.3	54.5	52.9	53.5	52.3	51.3
	10	9.6	TC	64.41	51.41	39.51	54.13	42.93	32.50	43.80	34.70	26.14
			SHC	38.22	33.97	29.59	30.51	26.84	23.02	23.98	20.98	17.84
			LDB	61.7	59.3	57.0	58.4	56.6	54.9	55.8	54.4	53.3
			LWB	58.2	56.1	54.0	55.2	53.7	52.3	52.6	51.6	50.8
	12	13.4	TC	68.26	54.26	41.37	56.36	44.64	33.67	44.89	35.50	26.81
			SHC	39.60	35.04	30.31	31.36	27.51	23.49	24.42	21.30	18.11
			LDB	60.9	58.6	56.5	57.7	56.0	54.5	55.2	54.0	52.9
			LWB	57.3	55.4	53.6	54.4	53.0	51.9	52.1	51.2	50.4
14	17.7	TC	71.36	56.52	42.85	57.99	45.86	34.55	45.68	36.09	27.27	
		SHC	40.75	35.89	30.89	31.98	27.99	23.84	24.73	21.54	18.30	
		LDB	60.2	58.1	56.2	57.1	55.6	54.2	54.8	53.7	52.7	
		LWB	56.6	54.8	53.2	53.8	52.6	51.5	51.7	50.9	50.2	

LEGEND

- EDB** — Entering Dry Bulb (F)
- EWB** — Entering Wet Bulb (F)
- EWT** — Entering Water Temperature (F)
- LDB** — Leaving Dry Bulb (F)
- LWB** — Leaving Wet Bulb (F)
- PD** — Water Pressure Drop (ft)
- SHC** — Sensible Capacity (1000 Btuh)
- TC** — Total Capacity (1000 Btuh)

NOTE: Direct interpolation is permissible. Do not extrapolate.

Performance data (cont)



40UH COOLING CAPACITY — CHILLED WATER COILS

SIZE 200 — 3 ROW

EWT (F)	GPM	PD (ft)		CFM								
				2000			1400			1000		
				Entering Air Temperature — EDB/EWB (F)								
				85/71	80/67	75/63	85/71	80/67	75/63	85/71	80/67	75/63
42	10	12.3	TC	69.81	58.28	47.35	60.62	50.43	40.80	51.67	42.74	34.58
			SHC	41.64	37.96	33.99	34.40	31.18	27.71	28.35	25.50	22.57
			LDB	66.0	62.6	59.5	62.5	59.6	56.9	59.1	56.7	54.4
			LWB	60.9	57.9	55.0	58.1	55.4	53.0	55.2	53.0	50.9
	12	17.1	TC	73.83	61.42	49.87	63.43	52.76	42.67	53.52	44.23	35.65
			SHC	43.12	39.17	35.00	35.49	32.11	28.49	29.11	26.12	23.03
			LDB	65.3	62.1	59.0	61.8	59.0	56.4	58.4	56.1	53.9
			LWB	60.2	57.3	54.6	57.4	54.8	52.5	54.5	52.4	50.4
	14	22.7	TC	77.14	64.16	52.01	65.59	54.34	43.92	54.77	45.33	36.45
			SHC	44.35	40.24	35.86	36.34	32.76	29.02	29.63	26.59	23.38
			LDB	64.7	61.6	58.6	61.3	58.6	56.0	57.9	55.7	53.6
			LWB	59.7	56.8	54.2	56.9	54.4	52.1	54.0	52.0	50.1
16	29.0	TC	79.61	66.05	53.44	67.24	55.73	44.91	55.80	46.07	36.99	
		SHC	45.29	40.99	36.45	37.00	33.33	29.44	30.06	26.91	23.61	
		LDB	64.3	61.3	58.3	60.8	58.2	55.8	57.5	55.4	53.4	
		LWB	59.3	56.5	53.9	56.5	54.1	51.9	53.6	51.7	49.9	
45	10	12.3	TC	63.21	51.87	41.32	55.11	44.98	35.36	47.05	38.23	30.03
			SHC	39.29	35.56	31.63	32.33	29.04	25.51	26.53	23.66	20.67
			LDB	67.0	63.7	60.5	63.9	61.0	58.3	60.7	58.4	56.1
			LWB	61.9	59.0	56.1	59.4	56.8	54.4	56.8	54.6	52.6
	12	17.1	TC	67.00	54.88	43.24	57.75	46.98	37.01	48.74	39.49	31.11
			SHC	40.63	36.68	32.37	33.31	29.82	26.17	27.19	24.17	21.11
			LDB	66.4	63.2	60.2	63.2	60.5	57.9	60.1	57.9	55.7
			LWB	61.3	58.4	55.7	58.8	56.3	54.0	56.2	54.2	52.2
	14	22.7	TC	69.96	57.12	45.00	59.72	48.56	38.26	50.00	40.57	31.84
			SHC	41.70	37.52	33.06	34.06	30.44	26.67	27.68	24.61	21.41
			LDB	65.9	62.8	59.9	62.8	60.1	57.6	59.7	57.5	55.4
			LWB	60.9	58.1	55.4	58.3	55.9	53.7	55.8	53.8	51.9
16	29.0	TC	72.49	58.97	46.44	61.22	49.80	39.08	50.99	41.33	32.43	
		SHC	42.62	38.23	33.63	34.63	30.93	27.01	28.08	24.92	21.66	
		LDB	65.5	62.5	59.6	62.4	59.8	57.4	59.3	57.2	55.2	
		LWB	60.4	57.7	55.2	57.9	55.6	53.4	55.4	53.5	51.7	
48	10	12.3	TC	56.39	45.44	35.37	49.34	39.33	30.10	42.29	33.59	25.48
			SHC	36.94	33.24	29.37	30.24	26.92	23.46	24.73	21.85	18.85
			LDB	68.1	64.8	61.6	65.2	62.4	59.7	62.4	60.0	57.8
			LWB	63.0	60.0	57.1	60.8	58.2	55.8	58.4	56.3	54.3
	12	17.1	TC	60.00	47.81	36.88	51.88	41.19	31.33	43.82	34.78	26.34
			SHC	38.17	34.09	29.93	31.15	27.61	23.93	25.30	22.31	19.18
			LDB	67.5	64.4	61.3	64.7	62.0	59.4	61.9	59.6	57.5
			LWB	62.4	59.6	56.9	60.2	57.8	55.5	57.9	55.9	54.0
	14	22.7	TC	62.74	49.99	38.23	53.68	42.61	32.27	45.00	35.73	27.02
			SHC	39.13	34.87	30.44	31.80	28.14	24.30	25.74	22.68	19.45
			LDB	67.1	64.1	61.1	64.2	61.6	59.1	61.5	59.3	57.2
			LWB	62.0	59.3	56.6	59.8	57.4	55.2	57.5	55.5	53.8
16	29.0	TC	64.80	51.54	39.31	55.09	43.74	33.21	46.01	36.40	27.45	
		SHC	39.85	35.44	30.86	32.32	28.57	24.67	26.13	22.94	19.63	
		LDB	66.8	63.8	60.9	63.9	61.3	58.9	61.1	59.0	57.1	
		LWB	61.7	59.0	56.4	59.4	57.1	55.0	57.2	55.3	53.6	

LEGEND

- EDB — Entering Dry Bulb (F)
- EWB — Entering Wet Bulb (F)
- EWT — Entering Water Temperature (F)
- LDB — Leaving Dry Bulb (F)
- LWB — Leaving Wet Bulb (F)
- PD — Water Pressure Drop (ft)
- SHC — Sensible Capacity (1000 Btuh)
- TC — Total Capacity (1000 Btuh)

NOTE: Direct interpolation is permissible. Do not extrapolate.



40UH COOLING CAPACITY — CHILLED WATER COILS (cont)

SIZE 200 — 4 ROW

EWT (F)	GPM	PD (ft)		CFM								
				2000			1400			1000		
				Entering Air Temperature — EDB/EWB (F)								
				85/71	80/67	75/63	85/71	80/67	75/63	85/71	80/67	75/63
42	10	11.0	TC	80.09	66.95	54.68	69.22	57.51	46.67	58.34	48.32	38.89
			SHC	47.67	43.49	39.04	39.04	35.34	31.45	31.81	28.61	25.20
			LDB	63.2	60.1	57.1	59.5	56.9	54.5	55.9	53.8	52.0
			LWB	59.2	56.4	53.7	55.9	53.6	51.4	52.7	50.8	49.1
	12	15.2	TC	85.17	71.09	57.78	72.74	60.30	48.88	60.50	49.99	40.28
			SHC	49.54	45.09	40.29	40.42	36.47	32.38	32.70	29.31	25.81
			LDB	62.3	59.4	56.6	58.6	56.2	53.9	55.1	53.2	51.4
			LWB	58.3	55.6	53.1	55.0	52.8	50.7	51.8	50.1	48.6
	14	20.2	TC	89.20	74.27	60.23	75.26	62.39	50.47	61.99	51.17	41.28
			SHC	51.06	46.34	41.29	41.43	37.33	33.05	33.32	29.82	26.24
			LDB	61.7	58.8	56.1	57.9	55.6	53.4	54.5	52.7	51.0
			LWB	57.6	55.0	52.6	54.4	52.3	50.3	51.3	49.7	48.2
	16	25.8	TC	92.62	76.78	62.26	77.25	64.03	51.54	63.13	51.99	41.94
			SHC	52.36	47.33	42.12	42.23	38.01	33.51	33.81	30.17	26.54
			LDB	61.1	58.4	55.7	57.4	55.2	53.1	54.1	52.4	50.7
			LWB	57.1	54.6	52.2	53.9	51.8	50.0	50.8	49.3	47.9
45	10	11.0	TC	72.49	59.68	47.89	62.95	51.34	40.64	53.13	43.21	34.00
			SHC	44.96	40.76	36.37	36.67	32.90	28.99	29.72	26.50	23.14
			LDB	64.4	61.4	58.4	61.0	58.5	56.1	57.8	55.8	53.8
			LWB	60.4	57.6	54.9	57.5	55.2	53.0	54.6	52.8	51.1
	12	15.2	TC	77.27	63.31	50.34	66.13	53.90	42.43	55.11	44.76	35.17
			SHC	46.66	42.11	37.32	37.86	33.90	29.71	30.50	27.13	23.63
			LDB	63.7	60.7	57.9	60.3	57.9	55.6	57.1	55.2	53.4
			LWB	59.7	57.0	54.5	56.7	54.5	52.5	53.9	52.2	50.6
	14	20.2	TC	81.11	66.22	52.29	68.49	55.70	43.85	56.58	45.84	36.03
			SHC	48.05	43.21	38.09	38.76	34.61	30.29	31.09	27.57	23.99
			LDB	63.0	60.2	57.6	59.7	57.4	55.2	56.6	54.8	53.1
			LWB	59.0	56.5	54.1	56.1	54.1	52.1	53.3	51.8	50.3
	16	25.8	TC	84.05	68.52	54.05	70.35	57.21	45.01	57.61	46.73	36.60
			SHC	49.13	44.09	38.79	39.48	35.21	30.76	31.51	27.94	24.23
			LDB	62.5	59.8	57.3	59.2	57.0	54.9	56.2	54.4	52.8
			LWB	58.5	56.1	53.8	55.7	53.7	51.8	52.9	51.4	50.1
48	10	11.0	TC	65.03	52.51	41.18	56.34	45.01	34.66	47.87	38.01	28.78
			SHC	42.38	38.16	33.82	34.26	30.51	26.65	27.71	24.46	21.04
			LDB	65.6	62.6	59.5	62.6	60.1	57.6	59.7	57.6	55.8
			LWB	61.6	58.8	56.1	59.1	56.8	54.6	56.5	54.7	53.1
	12	15.2	TC	69.25	55.55	43.08	59.42	47.19	36.12	49.72	39.47	29.78
			SHC	43.83	39.25	34.54	35.37	31.33	27.21	28.41	25.02	21.43
			LDB	65.0	62.1	59.2	61.9	59.5	57.2	59.0	57.1	55.4
			LWB	61.0	58.3	55.8	58.4	56.3	54.2	55.8	54.2	52.7
	14	20.2	TC	72.66	57.97	44.68	61.57	49.01	37.27	51.10	40.39	30.50
			SHC	45.02	40.13	35.14	36.16	32.01	27.66	28.94	25.38	21.72
			LDB	64.4	61.6	58.9	61.4	59.1	56.9	58.5	56.8	55.1
			LWB	60.4	57.9	55.5	57.9	55.8	53.9	55.4	53.8	52.5
	16	25.8	TC	75.30	60.00	45.92	63.40	50.32	38.15	52.07	41.08	31.07
			SHC	45.95	40.88	35.61	36.84	32.52	28.01	29.31	25.65	21.95
			LDB	64.0	61.3	58.7	60.9	58.8	56.7	58.2	56.5	54.9
			LWB	60.0	57.6	55.3	57.4	55.5	53.7	55.0	53.6	52.2

LEGEND

- EDB — Entering Dry Bulb (F)
- EWB — Entering Wet Bulb (F)
- EWT — Entering Water Temperature (F)
- LDB — Leaving Dry Bulb (F)
- LWB — Leaving Wet Bulb (F)
- PD — Water Pressure Drop (ft)
- SHC — Sensible Capacity (1000 Btuh)
- TC — Total Capacity (1000 Btuh)

NOTE: Direct interpolation is permissible. Do not extrapolate.

Performance data (cont)



40UH COOLING CAPACITY — CHILLED WATER COILS (cont)

SIZE 200 — HIGH CAPACITY

EWT (F)	GPM	PD (ft)		CFM								
				2000			1400			1000		
				Entering Air Temperature — EDB/EWB (F)								
				85/71	80/67	75/63	85/71	80/67	75/63	85/71	80/67	75/63
42	10	9.6	TC	87.89	73.71	60.44	75.57	62.86	51.03	63.20	52.18	42.16
			SHC	52.04	47.55	42.76	42.33	38.31	34.07	34.22	30.67	27.06
			LDB	61.2	58.3	55.4	57.4	55.0	52.7	53.7	52.0	50.3
			LWB	57.9	55.1	52.6	54.3	52.1	50.1	50.8	49.3	47.8
	12	13.4	TC	93.81	78.41	63.92	79.57	66.06	53.42	65.25	53.95	43.63
			SHC	54.23	49.38	44.17	43.91	39.62	35.08	35.08	31.43	27.71
			LDB	60.2	57.4	54.8	56.3	54.1	52.1	52.9	51.3	49.7
			LWB	56.8	54.3	51.9	53.2	51.2	49.4	50.0	48.5	47.2
	14	17.7	TC	98.65	82.06	66.68	82.44	68.33	55.26	66.86	55.36	44.61
			SHC	56.07	50.82	45.30	45.06	40.56	35.87	35.77	32.04	28.14
			LDB	59.4	56.8	54.3	55.6	53.5	51.6	52.3	50.7	49.3
			LWB	56.0	53.6	51.4	52.5	50.6	48.9	49.3	47.9	46.8
16	22.7	TC	102.32	85.01	68.89	84.59	69.98	56.46	68.13	56.27	45.31	
		SHC	57.48	52.00	46.22	45.95	41.26	36.39	36.32	32.44	28.45	
		LDB	58.7	56.2	53.9	55.0	53.0	51.2	51.8	50.3	49.0	
		LWB	55.3	53.0	50.9	51.9	50.1	48.6	48.8	47.6	46.5	
45	10	9.6	TC	79.93	65.98	53.00	68.65	56.18	44.57	57.54	46.81	36.74
			SHC	49.18	44.64	39.82	39.68	35.65	31.42	31.93	28.44	24.76
			LDB	62.5	59.6	56.8	59.1	56.7	54.5	55.8	54.0	52.4
			LWB	59.2	56.5	54.0	56.1	53.9	51.9	53.0	51.4	50.0
	12	13.4	TC	85.28	69.98	55.83	72.35	58.93	46.56	59.69	48.45	38.06
			SHC	51.10	46.14	40.93	41.08	36.73	32.23	32.79	29.11	25.31
			LDB	61.6	58.9	56.3	58.2	56.0	53.9	55.0	53.4	51.9
			LWB	58.3	55.8	53.4	55.1	53.2	51.4	52.1	50.7	49.5
	14	17.7	TC	89.53	73.16	58.12	75.02	61.06	48.09	61.14	49.62	38.78
			SHC	52.64	47.34	41.84	42.11	37.58	32.85	33.38	29.60	25.62
			LDB	60.9	58.4	55.9	57.5	55.4	53.5	54.5	52.9	51.6
			LWB	57.6	55.2	53.0	54.4	52.6	51.0	51.6	50.3	49.2
16	22.7	TC	93.05	75.79	59.99	77.15	62.66	49.24	62.29	50.35	39.48	
		SHC	53.95	48.36	42.58	42.94	38.23	33.33	33.85	29.90	25.91	
		LDB	60.3	57.9	55.5	56.9	55.0	53.2	54.0	52.7	51.3	
		LWB	57.0	54.8	52.6	53.9	52.2	50.6	51.1	50.0	48.9	
48	10	9.6	TC	71.74	58.20	45.64	61.72	49.43	38.11	51.88	41.19	31.28
			SHC	46.34	41.80	37.01	37.13	33.08	28.87	29.74	26.20	22.54
			LDB	63.8	60.9	58.1	60.7	58.4	56.1	57.8	56.0	54.4
			LWB	60.6	57.9	55.3	57.8	55.7	53.7	55.1	53.5	52.2
	12	13.4	TC	76.41	61.56	47.90	65.04	51.84	39.69	53.88	42.61	32.27
			SHC	47.95	43.01	37.86	38.34	33.99	29.49	30.50	26.76	22.94
			LDB	63.1	60.3	57.7	60.0	57.8	55.7	57.1	55.5	54.0
			LWB	59.8	57.3	54.9	57.0	55.1	53.3	54.3	53.0	51.8
	14	17.7	TC	80.30	64.31	49.69	67.53	53.69	40.82	55.22	43.63	33.04
			SHC	49.32	44.02	38.55	39.26	34.69	29.93	31.02	27.16	23.24
			LDB	62.5	59.9	57.4	59.4	57.3	55.5	56.6	55.2	53.7
			LWB	59.1	56.8	54.6	56.4	54.6	53.0	53.8	52.6	51.5
16	22.7	TC	83.39	66.59	51.17	69.53	55.19	41.79	56.19	44.44	33.60	
		SHC	50.42	44.86	39.12	40.01	35.27	30.31	31.40	27.48	23.47	
		LDB	61.9	59.5	57.1	58.9	57.0	55.2	56.3	54.9	53.5	
		LWB	58.6	56.4	54.3	55.9	54.2	52.7	53.5	52.3	51.3	

LEGEND

- EDB — Entering Dry Bulb (F)
- EWB — Entering Wet Bulb (F)
- EWT — Entering Water Temperature (F)
- LDB — Leaving Dry Bulb (F)
- LWB — Leaving Wet Bulb (F)
- PD — Water Pressure Drop (ft)
- SHC — Sensible Capacity (1000 Btuh)
- TC — Total Capacity (1000 Btuh)

NOTE: Direct interpolation is permissible. Do not extrapolate.



40UV HEATING CAPACITY — HOT WATER COILS

SIZE 050

NO. ROWS	EWT (F)	GPM	PD (ft)		CFM								
					500			350			250		
					Air Entering Temperature — EDB (F)								
					40	50	60	40	50	60	40	50	60
1	160	2	0.1	TC	13.18	12.08	10.99	11.05	10.14	9.21	9.27	8.50	7.72
				LDB	64.1	72.1	80.1	68.9	76.5	84.1	73.9	81.1	88.3
		4	0.5	TC	14.13	12.96	11.78	11.71	10.74	9.76	9.72	8.91	8.10
				LDB	65.9	73.7	81.5	70.6	78.1	85.5	75.6	82.6	89.6
		6	1.0	TC	14.51	13.30	12.09	11.97	10.97	9.97	9.90	9.07	8.25
				LDB	66.5	74.3	82.1	71.3	78.7	86.1	76.2	83.2	90.2
	180	2	0.1	TC	15.48	14.38	13.27	12.97	12.04	11.12	10.86	10.09	9.31
				LDB	68.3	76.3	84.3	73.9	81.5	89.0	79.7	86.9	94.1
		4	0.5	TC	16.56	15.38	14.19	13.71	12.73	11.75	11.38	10.56	9.75
				LDB	70.3	78.1	86.0	75.8	83.3	90.7	81.6	88.6	95.7
		6	1.0	TC	16.97	15.76	14.55	13.99	12.99	12.00	11.57	10.74	9.92
				LDB	71.0	78.8	86.6	76.6	84.0	91.3	82.3	89.3	96.3
2	160	4	0.9	TC	23.03	21.11	19.20	18.77	17.21	15.65	15.30	14.03	12.75
				LDB	82.1	88.6	95.1	89.1	95.0	100.9	96.0	101.3	106.7
		6	1.8	TC	23.68	21.71	19.74	19.19	17.59	15.99	15.57	14.28	12.98
				LDB	83.3	89.7	96.1	90.1	96.0	101.8	97.0	102.2	107.5
		8	3.0	TC	24.03	22.03	20.02	19.41	17.80	16.18	15.72	14.41	13.10
				LDB	83.9	90.3	96.6	90.7	96.5	102.3	97.5	102.7	107.9
	180	4	0.9	TC	26.96	25.03	23.11	21.96	20.39	18.82	17.89	16.62	15.34
				LDB	89.3	95.8	102.3	97.4	103.3	109.2	105.5	110.8	116.1
		6	1.8	TC	27.69	25.72	23.74	22.43	20.83	19.23	18.20	16.90	15.60
				LDB	90.7	97.0	103.4	98.6	104.4	110.2	106.6	111.8	117.1
		8	3.0	TC	28.09	26.08	24.08	22.69	21.07	19.45	18.36	17.05	15.74
				LDB	91.4	97.7	104.0	99.3	105.0	110.8	107.2	112.4	117.6
3	160	4	3.1	TC	26.09	23.92	21.75	21.02	19.27	17.52	16.95	15.54	14.12
				LDB	87.7	93.8	99.8	94.9	100.3	105.8	102.0	106.8	111.7
		6	6.2	TC	26.67	24.45	22.23	21.38	19.60	17.81	17.17	15.74	14.31
				LDB	88.8	94.7	100.7	95.9	101.2	106.5	102.8	107.6	112.3
		8	10.2	TC	26.97	24.73	22.48	21.56	19.77	17.97	17.29	15.85	14.41
				LDB	89.3	95.2	101.1	96.3	101.6	107.0	103.2	108.0	112.7
	180	4	3.1	TC	30.49	28.32	26.14	24.55	22.80	21.05	19.79	18.38	16.97
				LDB	95.8	101.8	107.8	104.2	109.6	115.0	112.4	117.2	122.1
		6	6.2	TC	31.15	28.93	26.71	24.96	23.18	21.40	20.05	18.62	17.18
				LDB	97.0	102.9	108.8	105.2	110.6	115.9	113.3	118.1	122.9
		8	10.2	TC	31.50	29.25	27.00	25.17	23.38	21.58	20.18	18.74	17.30
				LDB	97.6	103.5	109.4	105.8	111.1	116.4	113.8	118.5	123.3
4	160	4	4.2	TC	32.26	29.57	26.88	25.70	23.56	21.42	20.46	18.76	17.05
				LDB	99.0	104.1	109.2	107.1	111.5	116.0	114.9	118.6	122.4
		6	8.3	TC	33.04	30.29	27.53	26.16	23.98	21.80	20.74	19.01	17.28
				LDB	100.4	105.4	110.4	108.4	112.7	117.0	115.9	119.5	123.2
		8	13.6	TC	33.45	30.66	27.87	26.41	24.20	22.00	20.88	19.14	17.40
				LDB	101.2	106.1	111.0	109.0	113.2	117.5	116.4	120.0	123.7
	180	4	4.2	TC	37.69	35.00	32.30	30.01	27.87	25.73	23.90	22.19	20.48
				LDB	108.9	114.0	119.1	118.4	122.8	127.2	127.4	131.2	134.9
		6	8.3	TC	38.59	35.83	33.08	30.55	28.37	26.19	24.21	22.48	20.75
				LDB	110.6	115.5	120.5	119.8	124.1	128.4	128.6	132.2	135.9
		8	13.6	TC	39.05	36.26	33.48	30.83	28.62	26.42	24.37	22.63	20.89
				LDB	111.4	116.3	121.2	120.5	124.8	129.0	129.2	132.8	136.4
5	160	4	2.8	TC	35.95	32.96	29.96	28.43	26.06	23.69	22.45	20.58	18.71
				LDB	105.8	110.3	114.8	114.3	118.1	121.9	122.1	125.3	128.4
		6	5.6	TC	36.89	33.81	30.74	28.97	26.56	24.14	22.76	20.86	18.97
				LDB	107.5	111.8	116.2	115.7	119.4	123.1	123.3	126.3	129.4
		8	9.3	TC	37.37	34.25	31.14	29.24	26.81	24.37	22.92	21.01	19.10
				LDB	108.3	112.7	117.0	116.4	120.0	123.7	123.8	126.8	129.9
	180	4	2.8	TC	42.01	39.01	36.01	33.21	30.84	28.46	26.21	24.34	22.47
				LDB	116.8	121.3	125.9	126.8	130.6	134.4	135.9	139.0	142.2
		6	5.6	TC	43.08	40.00	36.93	33.83	31.41	28.99	26.57	24.67	22.77
				LDB	118.8	123.2	127.5	128.4	132.1	135.8	137.2	140.2	143.3
		8	9.3	TC	43.63	40.52	37.40	34.14	31.70	29.27	26.75	24.84	22.93
				LDB	119.8	124.1	128.4	129.2	132.8	136.5	137.9	140.9	143.9
5 (High Capacity)	160	4	2.8	TC	42.90	39.33	35.76	33.38	30.60	27.82	25.89	23.74	21.58
				LDB	118.5	121.9	125.4	127.2	129.9	132.7	134.7	136.8	138.9
		6	5.6	TC	44.04	40.37	36.70	33.99	31.16	28.33	26.22	24.03	21.85
				LDB	120.6	123.8	127.1	128.8	131.4	134.0	135.9	137.9	139.9
		8	9.3	TC	44.62	40.91	37.19	34.30	31.44	28.58	26.38	24.18	21.98
				LDB	121.6	124.8	128.0	129.6	132.1	134.7	136.5	138.5	140.4
	180	4	2.8	TC	50.12	46.54	42.96	38.98	36.19	33.41	30.23	28.07	25.91
				LDB	131.7	135.1	138.6	141.8	144.6	147.3	150.6	152.7	154.8
		6	5.6	TC	51.43	47.76	44.09	39.68	36.85	34.01	30.60	28.42	26.23
				LDB	134.1	137.4	140.6	143.7	146.3	148.9	151.9	153.9	155.9
		8	9.3	TC	52.10	48.38	44.66	40.04	37.18	34.32	30.79	28.59	26.39
				LDB	135.3	138.5	141.7	144.6	147.1	149.7	152.6	154.6	156.5

LEGEND

- EDB — Entering Dry Bulb (F)
- EWT — Entering Water Temperature (F)
- LDB — Leaving Dry Bulb (F)
- PD — Water Pressure Drop (ft)
- TC — Total Capacity (1000 Btuh)

NOTE: The maximum entering hot water temperature is 200 F. Customer must ensure that water vaporization does not occur, especially at higher elevations when entering hot water temperature is greater than 190 F.

Performance data (cont)



40UV,UH HEATING CAPACITY — HOT WATER COILS

SIZE 075

NO. ROWS	EWT (F)	GPM	PD (ft)		CFM								
					750			525			375		
					Air Entering Temperature — EDB (F)								
					40	50	60	40	50	60	40	50	60
1	160	2	0.2	TC	23.74	21.77	19.80	20.16	18.48	16.81	17.03	15.62	14.20
				LDB	68.9	76.5	84.1	75.1	82.2	89.3	81.5	88.1	94.6
		4	0.6	TC	26.38	24.19	21.99	22.00	20.17	18.34	18.32	16.79	15.27
				LDB	72.2	79.5	86.8	78.3	85.1	91.9	84.7	91.0	97.2
		6	1.3	TC	27.44	25.16	22.87	22.73	20.84	18.94	18.82	17.25	15.68
				LDB	73.5	80.7	87.9	79.6	86.3	93.0	85.9	92.1	98.2
	180	2	0.2	TC	27.91	25.93	23.94	23.67	21.99	20.30	19.98	18.56	17.13
				LDB	74.0	81.6	89.2	81.2	88.3	95.4	88.7	95.3	101.8
		4	0.6	TC	30.94	28.73	26.52	25.78	23.94	22.10	21.45	19.92	18.39
				LDB	77.7	85.0	92.3	84.9	91.7	98.5	92.3	98.6	104.8
		6	1.3	TC	32.14	29.84	27.55	26.60	24.70	22.80	22.01	20.44	18.87
				LDB	79.2	86.4	93.6	86.3	93.0	99.7	93.7	99.8	106.0
2	160	4	1.2	TC	41.42	37.98	34.53	33.89	31.06	28.24	27.59	25.29	22.99
				LDB	90.5	96.3	102.1	99.0	104.1	109.2	107.3	111.7	116.1
		6	2.4	TC	43.23	39.63	36.03	35.03	32.12	29.20	28.32	25.96	23.60
				LDB	92.7	98.3	103.9	101.0	105.9	110.9	109.1	113.3	117.5
		8	4.0	TC	44.20	40.52	36.84	35.65	32.68	29.71	28.70	26.31	23.92
				LDB	93.9	99.4	104.9	102.1	106.9	111.7	110.0	114.2	118.3
	180	4	1.2	TC	48.51	45.06	41.60	39.65	36.83	34.00	32.27	29.96	27.66
				LDB	99.2	104.9	110.7	109.1	114.1	119.2	118.7	123.1	127.5
		6	2.4	TC	50.59	46.98	43.37	40.97	38.05	35.12	33.10	30.73	28.37
				LDB	101.7	107.3	112.9	111.4	116.3	121.2	120.7	124.9	129.2
		8	4.0	TC	51.69	48.00	44.31	41.67	38.69	35.72	33.53	31.14	28.74
				LDB	103.0	108.5	114.0	112.6	117.4	122.2	121.8	125.9	130.1
3	160	4	4.3	TC	55.04	50.46	45.88	44.06	40.39	36.72	35.02	32.11	29.19
				LDB	107.1	111.5	115.9	116.7	120.4	124.0	125.4	128.3	131.2
		6	8.5	TC	57.27	52.51	47.73	45.35	41.57	37.79	35.75	32.78	29.80
				LDB	109.8	114.0	118.2	119.0	122.4	125.8	127.2	129.9	132.7
		8	14.0	TC	58.43	53.56	48.69	46.01	42.18	38.34	36.12	33.11	30.10
				LDB	111.2	115.3	119.4	120.1	123.5	126.8	128.1	130.8	133.4
	180	4	4.3	TC	64.34	59.76	55.17	51.48	47.81	44.14	40.91	37.99	35.07
				LDB	118.5	122.9	127.3	129.7	133.3	136.9	139.8	142.7	145.5
		6	8.5	TC	66.93	62.15	57.37	52.97	49.19	45.41	41.75	38.77	35.79
				LDB	121.6	125.8	130.0	132.3	135.7	139.1	141.8	144.5	147.3
		8	14.0	TC	68.26	63.38	58.51	53.73	49.89	46.06	42.18	39.16	36.15
				LDB	123.2	127.3	131.3	133.6	136.9	140.2	142.9	145.5	148.2
4	160	4	5.7	TC	57.65	52.85	48.05	45.83	42.01	38.19	36.19	33.18	30.16
				LDB	110.3	114.4	118.6	119.8	123.2	126.5	128.3	130.9	133.6
		6	11.3	TC	59.93	54.94	49.95	47.11	43.18	39.26	36.90	33.82	30.75
				LDB	113.1	117.0	120.9	122.1	125.2	128.4	130.0	132.5	135.0
		8	18.7	TC	61.09	56.00	50.91	47.76	43.78	39.80	37.26	34.15	31.05
				LDB	114.5	118.3	122.1	123.2	126.3	129.3	130.9	133.3	135.7
	180	4	5.7	TC	67.37	62.57	57.76	53.53	49.71	45.89	42.27	39.25	36.23
				LDB	122.1	126.3	130.4	133.2	136.6	139.9	143.1	145.7	148.4
		6	11.3	TC	70.00	65.01	60.01	55.01	51.08	47.15	43.08	40.00	36.93
				LDB	125.4	129.3	133.2	135.8	139.0	142.1	145.1	147.6	150.1
		8	18.7	TC	71.35	66.25	61.16	55.76	51.78	47.79	43.49	40.38	37.28
				LDB	127.0	130.8	134.6	137.1	140.2	143.3	146.1	148.5	150.9
5	160	4	3.9	TC	59.80	54.82	49.84	47.33	43.39	39.44	37.22	34.12	31.02
				LDB	112.9	116.8	120.8	122.4	125.6	128.7	130.8	133.2	135.6
		6	7.7	TC	62.19	57.01	51.83	48.65	44.60	40.54	37.93	34.77	31.61
				LDB	115.8	119.5	123.2	124.7	127.7	130.6	132.5	134.8	137.1
		8	12.7	TC	63.41	58.12	52.84	49.32	45.21	41.10	38.29	35.10	31.91
				LDB	117.3	120.9	124.4	125.9	128.7	131.6	133.4	135.6	137.8
	180	4	3.9	TC	69.88	64.89	59.91	55.28	51.34	47.39	43.46	40.36	37.26
				LDB	125.2	129.1	133.0	136.3	139.4	142.6	146.0	148.4	150.9
		6	7.7	TC	72.64	67.46	62.27	56.81	52.76	48.70	44.29	41.12	37.96
				LDB	128.6	132.2	135.9	139.0	141.9	144.8	148.0	150.3	152.6
		8	12.7	TC	74.05	68.76	63.47	57.58	53.47	49.36	44.70	41.51	38.32
				LDB	130.3	133.8	137.4	140.3	143.1	146.0	149.0	151.2	153.4
5 (High Capacity)	160	4	3.9	TC	69.65	63.86	58.06	54.18	49.67	45.16	41.79	38.31	34.83
				LDB	124.9	127.9	130.8	134.4	136.5	138.7	141.9	143.4	144.9
		6	7.7	TC	72.44	66.41	60.38	55.59	50.96	46.33	42.48	38.94	35.40
				LDB	128.3	131.0	133.6	136.8	138.8	140.7	143.6	145.0	146.3
		8	12.7	TC	73.83	67.68	61.53	56.28	51.59	46.90	42.81	39.24	35.67
				LDB	130.0	132.5	135.0	138.0	139.9	141.7	144.4	145.7	147.0
	180	4	3.9	TC	81.37	75.57	69.76	63.27	58.76	54.24	48.79	45.31	41.82
				LDB	139.2	142.1	145.1	150.2	152.4	154.5	159.0	160.5	162.0
		6	7.7	TC	84.60	78.56	72.52	64.90	60.27	55.63	49.58	46.04	42.50
				LDB	143.2	145.8	148.4	153.1	155.0	156.9	160.9	162.3	163.6
		8	12.7	TC	86.21	80.05	73.90	65.70	61.00	56.31	49.96	46.39	42.83
				LDB	145.1	147.6	150.1	154.4	156.3	158.1	161.8	163.1	164.4

LEGEND

- EDB — Entering Dry Bulb (F)
- EWT — Entering Water Temperature (F)
- LDB — Leaving Dry Bulb (F)
- PD — Water Pressure Drop (ft)
- TC — Total Capacity (1000 Btuh)

NOTE: The maximum entering hot water temperature is 200 F. Customer must ensure that water vaporization does not occur, especially at higher elevations when entering hot water temperature is greater than 190 F.



40UV,UH HEATING CAPACITY — HOT WATER COILS (cont)

SIZE 100

NO. ROWS	EWT (F)	GPM	PD (ft)		CFM								
					1000			700			500		
					Air Entering Temperature — EDB (F)								
					40	50	60	40	50	60	40	50	60
1	160	2	0.2	TC	30.53	28.00	25.46	26.07	23.91	21.74	22.15	20.31	18.47
				LDB	67.9	75.6	83.3	74.1	81.2	88.4	80.5	87.1	93.8
		4	0.8	TC	34.52	31.65	28.77	28.88	26.48	24.07	24.11	22.10	20.10
				LDB	71.6	78.9	86.3	77.7	84.6	91.5	84.1	90.4	96.8
		6	1.6	TC	36.12	33.11	30.10	29.99	27.49	24.99	24.87	22.80	20.73
				LDB	73.0	80.3	87.5	79.2	85.9	92.6	85.5	91.7	97.9
	180	2	0.2	TC	35.87	33.33	30.78	30.61	28.43	26.25	25.98	24.13	22.28
				LDB	72.8	80.5	88.2	80.0	87.1	94.3	87.5	94.1	100.7
		4	0.8	TC	40.47	37.59	34.70	33.84	31.43	29.01	28.23	26.21	24.20
				LDB	77.0	84.4	91.7	84.2	91.1	97.9	91.6	97.9	104.3
		6	1.6	TC	42.29	39.27	36.26	35.09	32.59	30.08	29.09	27.01	24.94
				LDB	78.7	85.9	93.2	85.8	92.6	99.3	93.2	99.4	105.6
2	160	4	1.5	TC	53.75	49.28	44.82	44.24	40.56	36.88	36.20	33.18	30.17
				LDB	89.2	95.1	101.0	97.8	103.0	108.2	106.2	110.7	115.2
		6	3.0	TC	56.62	51.90	47.19	46.07	42.23	38.40	37.36	34.24	31.13
				LDB	91.8	97.5	103.2	100.2	105.2	110.2	108.3	112.6	116.9
		8	4.9	TC	58.15	53.30	48.46	47.04	43.12	39.20	37.96	34.80	31.64
				LDB	93.2	98.7	104.3	101.5	106.3	111.2	109.4	113.7	117.9
	180	4	1.5	TC	62.94	58.46	53.97	51.77	48.08	44.39	42.33	39.31	36.29
				LDB	97.6	103.5	109.4	107.6	112.8	118.0	117.4	121.9	126.4
		6	3.0	TC	66.24	61.52	56.79	53.88	50.03	46.18	43.66	40.54	37.43
				LDB	100.6	106.3	111.9	110.4	115.4	120.3	119.9	124.2	128.5
		8	4.9	TC	68.01	63.15	58.29	54.98	51.06	47.13	44.36	41.19	38.02
				LDB	102.2	107.7	113.3	111.8	116.7	121.6	121.1	125.3	129.5
3	160	4	5.4	TC	65.76	60.29	54.82	53.25	48.82	44.39	42.83	39.26	35.70
				LDB	100.1	105.1	110.1	109.6	113.8	118.0	118.3	121.8	125.3
		6	10.7	TC	69.00	63.25	57.51	55.19	50.59	45.99	43.96	40.29	36.63
				LDB	103.1	107.8	112.6	112.1	116.1	120.1	120.4	123.7	127.0
		8	17.7	TC	70.68	64.79	58.90	56.17	51.49	46.81	44.53	40.82	37.11
				LDB	104.6	109.3	113.9	113.4	117.3	121.2	121.4	124.7	127.9
	180	4	5.4	TC	76.87	71.38	65.90	62.22	57.79	53.35	50.03	46.46	42.89
				LDB	110.3	115.3	120.3	121.3	125.5	129.7	131.5	135.0	138.4
		6	10.7	TC	80.61	74.86	69.11	64.46	59.86	55.25	51.33	47.67	44.00
				LDB	113.7	118.5	123.2	124.2	128.2	132.2	133.9	137.2	140.5
		8	17.7	TC	82.56	76.66	70.77	65.60	60.91	56.23	51.99	48.28	44.56
				LDB	115.5	120.1	124.7	125.7	129.6	133.5	135.1	138.3	141.5
4	160	4	7.3	TC	74.86	68.63	62.40	60.05	55.05	50.05	47.74	43.77	39.79
				LDB	108.5	112.8	117.1	118.5	121.9	125.4	127.3	130.1	132.8
		6	14.4	TC	78.73	72.17	65.62	62.25	57.07	51.88	48.96	44.88	40.80
				LDB	112.0	116.0	120.0	121.3	124.6	127.8	129.5	132.1	134.6
		8	23.7	TC	80.72	74.00	67.27	63.36	58.08	52.80	49.57	45.44	41.31
				LDB	113.8	117.7	121.5	122.8	125.9	129.0	130.7	133.1	135.6
	180	4	7.3	TC	87.48	81.24	75.00	70.15	65.14	60.14	55.75	51.77	47.79
				LDB	120.0	124.3	128.6	131.6	135.1	138.6	142.0	144.7	147.4
		6	14.4	TC	91.97	85.40	78.84	72.69	67.51	62.32	57.16	53.08	49.00
				LDB	124.1	128.1	132.1	135.0	138.2	141.4	144.5	147.1	149.6
		8	23.7	TC	94.26	87.54	80.81	73.98	68.70	63.41	57.86	53.73	49.60
				LDB	126.2	130.1	133.9	136.6	139.7	142.8	145.8	148.3	150.7
5	160	4	4.9	TC	83.65	76.69	69.73	66.50	60.96	55.43	52.25	47.90	43.55
				LDB	116.5	120.1	123.8	126.9	129.6	132.4	135.6	137.6	139.6
		6	9.8	TC	88.24	80.90	73.55	68.97	63.22	57.48	53.53	49.07	44.61
				LDB	120.7	124.0	127.3	130.1	132.6	135.1	137.9	139.8	141.6
		8	16.1	TC	90.57	83.03	75.48	70.19	64.34	58.49	54.15	49.64	45.13
				LDB	122.8	125.9	129.0	131.7	134.1	136.4	139.0	140.8	142.5
	180	4	4.9	TC	97.76	90.79	83.82	77.68	72.14	66.60	61.02	56.66	52.31
				LDB	129.4	133.0	136.7	141.5	144.2	147.0	151.6	153.6	155.7
		6	9.8	TC	103.08	95.73	88.37	80.54	74.79	69.04	62.49	58.03	53.57
				LDB	134.3	137.5	140.8	145.2	147.7	150.2	154.3	156.1	158.0
		8	16.1	TC	105.77	98.22	90.67	81.95	76.10	70.25	63.22	58.70	54.19
				LDB	136.7	139.8	142.9	147.1	149.4	151.8	155.6	157.4	159.1
5 (High Capacity)	160	4	4.9	TC	95.85	87.89	79.91	74.92	68.68	62.44	57.70	52.90	48.09
				LDB	127.7	130.4	133.1	137.9	139.7	141.6	145.5	146.8	148.0
		6	9.8	TC	101.10	92.69	84.27	77.44	70.99	64.54	58.85	53.95	49.05
				LDB	132.5	134.8	137.1	141.2	142.7	144.3	147.6	148.7	149.7
		8	16.1	TC	103.65	95.02	86.38	78.64	72.09	65.54	59.39	54.44	49.49
				LDB	134.8	136.9	139.0	142.7	144.2	145.6	148.6	149.6	150.5
	180	4	4.9	TC	111.99	104.00	96.02	87.49	81.25	75.01	67.37	62.56	57.75
				LDB	142.4	145.1	147.8	154.3	156.1	158.0	163.2	164.4	165.6
		6	9.8	TC	118.07	109.65	101.22	90.41	83.96	77.50	68.69	63.79	58.88
				LDB	148.0	150.3	152.6	158.1	159.7	161.2	165.6	166.7	167.7
		8	16.1	TC	121.02	112.38	103.74	91.80	85.24	78.68	69.31	64.36	59.41
				LDB	150.7	152.8	154.9	159.9	161.4	162.8	166.8	167.7	168.7

LEGEND

- EDB — Entering Dry Bulb (F)
- EWT — Entering Water Temperature (F)
- LDB — Leaving Dry Bulb (F)
- PD — Water Pressure Drop (ft)
- TC — Total Capacity (1000 Btuh)

NOTE: The maximum entering hot water temperature is 200 F. Customer must ensure that water vaporization does not occur, especially at higher elevations when entering hot water temperature is greater than 190 F.

Performance data (cont)



40UV,UH HEATING CAPACITY — HOT WATER COILS (cont)

SIZE 125

NO. ROWS	EWT (F)	GPM	PD (ft)		CFM								
					1250			875			625		
					Air Entering Temperature — EDB (F)								
					40	50	60	40	50	60	40	50	60
1	160	2	0.3	TC	36.78	33.74	30.70	31.60	28.98	26.36	26.98	24.74	22.50
				LDB	66.9	74.7	82.5	73.0	80.3	87.5	79.5	86.2	92.9
		4	0.9	TC	42.30	38.78	35.27	35.52	32.56	29.60	29.73	27.25	24.78
				LDB	70.9	78.4	85.8	77.1	84.0	90.9	83.5	89.9	96.3
		6	1.9	TC	44.53	40.82	37.11	37.05	33.97	30.88	30.79	28.23	25.66
				LDB	72.6	79.9	87.2	78.7	85.5	92.3	85.1	91.3	97.6
	180	2	0.3	TC	43.22	40.16	37.09	37.09	34.46	31.82	31.64	29.39	27.13
				LDB	71.6	79.4	87.1	78.8	86.0	93.3	86.3	93.0	99.7
		4	0.9	TC	49.58	46.06	42.52	41.60	38.63	35.67	34.81	32.32	29.84
				LDB	76.3	83.7	91.1	83.5	90.4	97.3	90.9	97.3	103.7
		6	1.9	TC	52.15	48.43	44.70	43.36	40.27	37.17	36.01	33.44	30.87
				LDB	78.2	85.4	92.7	85.3	92.1	98.8	92.7	98.9	105.2
2	160	4	1.8	TC	65.33	59.91	54.48	54.09	49.60	45.10	44.48	40.78	37.08
				LDB	87.8	93.8	99.9	96.5	101.8	107.1	105.1	109.7	114.3
		6	3.6	TC	69.44	63.66	57.88	56.75	52.02	47.30	46.16	42.32	38.47
				LDB	90.8	96.6	102.3	99.3	104.4	109.4	107.5	111.9	116.3
		8	5.9	TC	71.65	65.69	59.71	58.14	53.30	48.46	47.04	43.13	39.21
				LDB	92.4	98.1	103.7	100.8	105.7	110.6	108.8	113.1	117.4
	180	4	1.8	TC	76.50	71.05	65.60	63.30	58.79	54.28	52.02	48.31	44.60
				LDB	96.0	102.0	108.0	106.2	111.4	116.7	116.1	120.7	125.3
		6	3.6	TC	81.24	75.44	69.65	66.35	61.62	56.89	53.96	50.11	46.25
				LDB	99.4	105.2	111.0	109.3	114.4	119.5	119.0	123.3	127.7
		8	5.9	TC	83.78	77.80	71.83	67.97	63.11	58.26	54.97	51.04	47.12
				LDB	101.3	106.9	112.5	111.0	116.0	120.9	120.4	124.7	128.9
3	160	6	7.2	TC	87.16	79.90	72.65	70.06	64.23	58.39	55.96	51.29	46.63
				LDB	103.8	108.5	113.1	113.2	117.1	121.0	121.9	125.1	128.2
		8	11.9	TC	89.89	82.40	74.92	71.66	65.69	59.72	56.88	52.14	47.40
				LDB	105.8	110.3	114.8	114.9	118.7	122.4	123.2	126.3	129.4
		10	17.6	TC	91.57	83.95	76.31	72.64	66.58	60.53	57.43	52.65	47.86
				LDB	107.0	111.4	115.8	115.9	119.6	123.3	124.0	127.0	130.0
	180	6	7.2	TC	101.86	94.60	87.33	81.85	76.01	70.16	65.35	60.69	56.02
				LDB	114.5	119.2	123.9	125.5	129.4	133.3	135.6	138.8	142.0
		8	11.9	TC	105.02	97.52	90.03	83.70	77.72	71.75	66.42	61.67	56.93
				LDB	116.8	121.3	125.9	127.5	131.2	135.0	137.2	140.2	143.3
		10	17.6	TC	106.96	99.33	91.69	84.83	78.77	72.71	67.05	62.27	57.48
				LDB	118.3	122.7	127.1	128.7	132.3	136.0	138.1	141.1	144.1
4	160	8	9.5	TC	98.72	90.51	82.28	77.97	71.48	64.98	61.28	56.17	51.07
				LDB	112.2	116.2	120.2	121.5	124.7	127.9	129.7	132.2	134.7
		10	14.1	TC	100.63	92.25	83.87	79.04	72.45	65.87	61.86	56.70	51.55
				LDB	113.6	117.5	121.4	122.6	125.7	128.8	130.5	133.0	135.4
		12	19.6	TC	101.92	93.43	84.93	79.75	73.11	66.46	62.25	57.06	51.88
				LDB	114.6	118.3	122.1	123.3	126.4	129.5	131.1	133.5	135.9
	180	8	9.5	TC	115.34	107.10	98.87	91.06	84.56	78.06	71.55	66.44	61.33
				LDB	124.4	128.4	132.3	135.2	138.4	141.6	144.7	147.2	149.7
		10	14.1	TC	117.53	109.15	100.75	92.29	85.70	79.11	72.22	67.06	61.90
				LDB	126.0	129.9	133.7	136.5	139.6	142.7	145.7	148.1	150.6
		12	19.6	TC	119.02	110.52	102.03	93.11	86.46	79.81	72.67	67.48	62.29
				LDB	127.1	130.9	134.6	137.3	140.4	143.4	146.3	148.7	151.1
5	160	8	5.5	TC	106.55	97.68	88.81	83.47	76.51	69.56	65.02	59.60	54.18
				LDB	117.9	121.5	125.0	127.2	130.0	132.7	135.1	137.2	139.3
		10	8.2	TC	108.68	99.63	90.58	84.62	77.57	70.52	65.62	60.15	54.68
				LDB	119.5	122.9	126.3	128.4	131.1	133.7	136.0	138.0	140.0
		12	11.5	TC	110.12	100.95	91.77	85.38	78.27	71.15	66.02	60.52	55.02
				LDB	120.6	123.9	127.1	129.2	131.8	134.4	136.6	138.6	140.5
	180	8	5.5	TC	124.48	115.60	106.72	97.48	90.52	83.56	75.91	70.49	65.07
				LDB	131.1	134.6	138.1	141.9	144.6	147.3	151.1	153.1	155.2
		10	8.2	TC	126.95	117.89	108.83	98.81	91.75	84.70	76.61	71.13	65.66
				LDB	132.9	136.2	139.6	143.3	145.9	148.5	152.1	154.1	156.1
		12	11.5	TC	128.61	119.42	110.24	99.69	92.57	85.45	77.07	71.56	66.06
				LDB	134.1	137.4	140.7	144.2	146.8	149.3	152.8	154.7	156.7
5 (High Capacity)	160	8	5.5	TC	123.05	112.81	102.56	94.54	86.66	78.79	72.14	66.13	60.11
				LDB	130.0	132.5	135.0	138.8	140.6	142.3	145.5	146.8	148.0
		10	8.2	TC	125.44	115.00	104.55	95.70	87.73	79.75	72.68	66.62	60.57
				LDB	131.8	134.1	136.5	140.0	141.7	143.4	146.3	147.5	148.6
		12	11.5	TC	127.03	116.45	105.86	96.46	88.42	80.38	73.03	66.95	60.86
				LDB	132.9	135.2	137.5	140.8	142.4	144.0	146.9	148.0	149.1
	180	8	5.5	TC	143.72	133.47	123.21	110.38	102.50	94.62	84.21	78.19	72.18
				LDB	145.1	147.6	150.1	155.4	157.1	158.9	163.2	164.4	165.6
		10	8.2	TC	146.49	136.04	125.58	111.72	103.75	95.77	84.83	78.77	72.71
				LDB	147.2	149.5	151.9	156.8	158.4	160.1	164.1	165.3	166.4
		12	11.5	TC	148.32	137.73	127.14	112.60	104.56	96.52	85.24	79.15	73.06
				LDB	148.5	150.8	153.0	157.7	159.3	160.9	164.7	165.8	166.9

LEGEND

- EDB — Entering Dry Bulb (F)
- EWT — Entering Water Temperature (F)
- LDB — Leaving Dry Bulb (F)
- PD — Water Pressure Drop (ft)
- TC — Total Capacity (1000 Btuh)

NOTE: The maximum entering hot water temperature is 200 F. Customer must ensure that water vaporization does not occur, especially at higher elevations when entering hot water temperature is greater than 190 F.



40UV,UH HEATING CAPACITY — HOT WATER COILS (cont)

SIZE 150

NO. ROWS	EWT (F)	GPM	PD (ft)		CFM								
					1500			1050			750		
					Air Entering Temperature — EDB (F)								
					40	50	60	40	50	60	40	50	60
1	160	2	0.3	TC	43.12	39.55	35.98	37.25	34.17	31.08	31.95	29.30	26.65
				LDB	66.3	74.1	81.9	72.4	79.8	87.1	79.0	85.7	92.5
		4	1.1	TC	50.50	46.31	42.11	42.53	38.99	35.46	35.69	32.72	29.74
				LDB	70.8	78.2	85.7	77.0	84.0	90.9	83.5	89.9	96.3
		6	2.2	TC	53.55	49.09	44.63	44.63	40.91	37.20	37.13	34.04	30.95
				LDB	72.6	79.9	87.2	78.9	85.6	92.4	85.3	91.5	97.7
	180	2	0.3	TC	50.64	47.07	43.47	43.72	40.62	37.51	37.46	34.80	32.13
				LDB	70.9	78.7	86.5	78.1	85.4	92.7	85.7	92.4	99.2
		4	1.1	TC	59.20	54.98	50.77	49.82	46.26	42.72	41.77	38.79	35.81
				LDB	76.1	83.5	91.0	83.4	90.3	97.2	90.9	97.3	103.7
		6	2.2	TC	62.70	58.22	53.75	52.24	48.51	44.78	43.43	40.33	37.23
				LDB	78.2	85.5	92.8	85.5	92.2	99.0	93.0	99.2	105.4
2	160	4	2.1	TC	77.57	71.13	64.68	64.57	59.21	53.84	53.31	48.87	44.44
				LDB	87.3	93.4	99.4	96.2	101.6	106.9	105.0	109.6	114.2
		6	4.2	TC	83.29	76.36	69.43	68.29	62.60	56.92	55.67	51.04	46.40
				LDB	90.8	96.6	102.3	99.5	104.5	109.6	107.9	112.2	116.6
		8	6.9	TC	86.39	79.20	72.01	70.26	64.41	58.55	56.91	52.16	47.42
				LDB	92.7	98.3	103.9	101.2	106.1	111.0	109.4	113.6	117.8
	180	4	2.1	TC	90.82	84.36	77.89	75.56	70.18	64.79	62.34	57.90	53.45
				LDB	95.4	101.4	107.5	105.8	111.1	116.4	116.0	120.6	125.2
		6	4.2	TC	97.44	90.50	83.55	79.85	74.15	68.46	65.07	60.43	55.78
				LDB	99.4	105.2	110.9	109.5	114.6	119.6	119.3	123.7	128.0
		8	6.9	TC	101.02	93.81	86.61	82.12	76.26	70.40	66.49	61.74	57.00
				LDB	101.6	107.2	112.8	111.5	116.4	121.3	121.1	125.3	129.5
3	160	6	5.0	TC	101.07	92.67	84.26	81.85	75.04	68.22	65.77	60.29	54.82
				LDB	101.6	106.5	111.4	111.3	115.4	119.4	120.2	123.5	126.8
		8	8.3	TC	104.85	96.13	87.40	84.10	77.09	70.09	67.08	61.49	55.90
				LDB	103.9	108.6	113.3	113.2	117.1	121.0	121.8	125.0	128.2
		10	12.3	TC	107.19	98.27	89.34	85.47	78.35	71.23	67.87	62.21	56.56
				LDB	105.4	109.9	114.5	114.4	118.2	122.0	122.8	125.9	129.0
	180	6	5.0	TC	118.15	109.73	101.30	95.64	88.82	81.99	76.83	71.34	65.86
				LDB	112.0	116.9	121.8	123.3	127.4	131.4	133.7	137.0	140.3
		8	8.3	TC	122.53	113.79	105.04	98.24	91.23	84.21	78.34	72.74	67.15
				LDB	114.7	119.4	124.0	125.6	129.5	133.3	135.5	138.7	141.9
		10	12.3	TC	125.23	116.29	107.36	99.82	92.70	85.57	79.25	73.59	67.93
				LDB	116.3	120.9	125.5	126.9	130.7	134.5	136.6	139.7	142.8
4	160	8	7.4	TC	121.13	111.05	100.96	95.96	87.97	79.98	75.46	69.18	62.89
				LDB	113.8	117.7	121.6	123.6	126.6	129.7	132.0	134.3	136.7
		10	11.0	TC	124.00	113.68	103.35	97.56	89.43	81.31	76.32	69.96	63.60
				LDB	115.6	119.3	123.0	125.0	127.9	130.8	133.1	135.3	137.6
		12	15.2	TC	125.95	115.46	104.97	98.63	90.41	82.19	76.89	70.48	64.08
				LDB	116.8	120.4	124.0	125.9	128.7	131.6	133.8	135.9	138.1
	180	8	7.4	TC	141.53	131.44	121.34	112.09	104.09	96.09	88.12	81.83	75.53
				LDB	126.3	130.1	134.0	137.6	140.7	143.7	147.4	149.8	152.1
		10	11.0	TC	144.86	134.53	124.19	113.93	105.80	97.66	89.11	82.74	76.38
				LDB	128.3	132.0	135.7	139.2	142.1	145.1	148.7	150.9	153.1
		12	15.2	TC	147.11	136.61	126.11	115.16	106.94	98.72	89.76	83.35	76.94
				LDB	129.7	133.3	136.9	140.3	143.1	146.0	149.5	151.6	153.8
5	160	8	6.5	TC	129.85	119.05	108.24	102.04	93.54	85.04	79.53	72.90	66.28
				LDB	119.2	122.6	126.0	128.9	131.5	134.1	137.0	138.9	140.8
		10	9.6	TC	132.98	121.91	110.84	103.70	95.06	86.43	80.39	73.69	66.99
				LDB	121.1	124.3	127.6	130.3	132.8	135.3	138.0	139.9	141.7
		12	13.4	TC	135.08	123.83	112.58	104.81	96.08	87.34	80.95	74.21	67.46
				LDB	122.4	125.5	128.6	131.3	133.7	136.1	138.7	140.5	142.3
	180	8	6.5	TC	151.72	140.90	130.07	119.18	110.67	102.16	92.86	86.23	79.60
				LDB	132.5	135.9	139.3	143.8	146.4	149.0	153.2	155.1	157.1
		10	9.6	TC	155.33	144.25	133.17	121.10	112.45	103.81	93.85	87.15	80.44
				LDB	134.7	137.9	141.2	145.5	147.9	150.4	154.4	156.3	158.1
		12	13.4	TC	157.76	146.50	135.24	122.37	113.64	104.90	94.50	87.75	81.00
				LDB	136.2	139.3	142.5	146.6	149.0	151.4	155.2	157.0	158.8
5 (High Capacity)	160	8	6.5	TC	148.99	136.59	124.19	114.83	105.26	95.70	87.64	80.34	73.04
				LDB	130.8	133.3	135.7	140.0	141.7	143.3	146.9	148.0	149.1
		10	9.6	TC	152.49	139.79	127.09	116.49	106.78	97.08	88.39	81.03	73.66
				LDB	133.0	135.2	137.5	141.5	143.0	144.6	147.8	148.8	149.8
		12	13.4	TC	154.78	141.89	129.00	117.57	107.77	97.98	88.88	81.47	74.07
				LDB	134.4	136.5	138.6	142.4	143.9	145.3	148.4	149.3	150.3
	180	8	6.5	TC	174.03	161.61	149.20	134.07	124.50	114.93	102.30	95.00	87.69
				LDB	146.1	148.5	151.0	156.8	158.4	160.1	164.7	165.8	166.9
		10	9.6	TC	178.07	165.36	152.66	135.99	126.28	116.57	103.17	95.80	88.44
				LDB	148.6	150.8	153.1	158.4	160.0	161.5	165.8	166.8	167.8
		12	13.4	TC	180.73	167.83	154.92	137.24	127.44	117.64	103.73	96.33	88.92
				LDB	150.2	152.3	154.5	159.5	161.0	162.5	166.5	167.5	168.4

LEGEND

- EDB — Entering Dry Bulb (F)
- EWT — Entering Water Temperature (F)
- LDB — Leaving Dry Bulb (F)
- PD — Water Pressure Drop (ft)
- TC — Total Capacity (1000 Btuh)

NOTE: The maximum entering hot water temperature is 200 F. Customer must ensure that water vaporization does not occur, especially at higher elevations when entering hot water temperature is greater than 190 F.

Performance data (cont)



40UH HEATING CAPACITY — HOT WATER COILS

SIZE 200													
NO. ROWS	EWT (F)	GPM	PD (ft)		CFM								
					2000			1400			1000		
					Air Entering Temperature — EDB (F)								
					40	50	60	40	50	60	40	50	60
1	160	2	0.3	TC	58.20	53.41	48.60	51.11	46.90	42.66	44.41	40.73	37.05
				LDB	66.6	74.4	82.2	73.4	80.6	87.9	80.6	87.3	93.9
		4	1.1	TC	71.75	65.80	59.85	61.00	55.93	50.86	51.50	47.22	42.94
				LDB	72.8	80.1	87.4	79.8	86.5	93.2	87.1	93.2	99.3
		6	2.2	TC	77.62	71.17	64.72	65.10	59.68	54.27	54.35	49.83	45.30
				LDB	75.5	82.5	89.6	82.5	89.0	95.4	89.7	95.6	101.4
	180	2	0.3	TC	68.35	63.53	58.69	59.97	55.73	51.48	52.07	48.38	44.68
				LDB	71.3	79.0	86.8	79.2	86.4	93.6	87.6	94.2	100.9
		4	1.1	TC	84.12	78.14	72.16	71.45	66.36	61.28	60.29	56.00	51.70
				LDB	78.5	85.7	93.0	86.7	93.3	100.0	95.1	101.2	107.3
		6	2.2	TC	90.90	84.43	77.95	76.19	70.76	65.33	63.58	59.04	54.51
				LDB	81.6	88.6	95.6	89.8	96.2	102.7	98.1	104.0	109.8
2	160	4	2.1	TC	106.48	97.65	88.83	89.86	82.40	74.94	74.83	68.61	62.38
				LDB	88.7	94.7	100.6	98.7	103.8	108.9	108.4	112.7	117.0
		6	4.2	TC	117.40	107.64	97.89	96.99	88.93	80.86	79.36	72.76	66.15
				LDB	93.7	99.2	104.8	103.4	108.1	112.8	112.6	116.5	120.5
		8	6.9	TC	123.44	113.17	102.90	100.82	92.43	84.04	81.74	74.93	68.13
				LDB	96.4	101.7	107.0	105.9	110.4	114.9	114.7	118.5	122.3
	180	4	2.1	TC	124.67	115.81	106.95	105.15	97.67	90.19	87.51	81.28	75.04
				LDB	97.0	103.0	108.9	108.7	113.8	118.9	120.0	124.3	128.6
		6	4.2	TC	137.36	127.58	117.79	113.42	105.34	97.25	92.76	86.15	79.53
				LDB	102.8	108.3	113.9	114.1	118.8	123.5	124.8	128.8	132.7
		8	6.9	TC	144.35	134.06	123.77	117.86	109.45	101.04	95.51	88.69	81.87
				LDB	106.0	111.3	116.6	117.0	121.5	126.0	127.3	131.1	134.9
3	160	6	5.0	TC	139.03	127.47	115.91	113.55	104.11	94.66	91.59	83.97	76.34
				LDB	103.6	108.3	113.0	114.2	118.0	121.8	123.8	126.8	129.8
		8	8.3	TC	146.21	134.05	121.88	117.79	107.98	98.17	94.00	86.17	78.34
				LDB	106.9	111.3	115.7	116.9	120.5	124.1	126.0	128.8	131.6
		10	12.3	TC	150.67	138.13	125.58	120.36	110.34	100.31	95.45	87.50	79.54
				LDB	108.9	113.2	117.4	118.6	122.1	125.5	127.3	130.0	132.7
	180	6	5.0	TC	162.52	150.94	139.37	132.69	123.23	113.76	106.99	99.35	91.72
				LDB	114.3	119.0	123.7	126.7	130.5	134.3	137.8	140.9	143.9
		8	8.3	TC	170.86	158.68	146.49	137.59	127.78	117.96	109.78	101.94	94.10
				LDB	118.1	122.6	127.0	129.9	133.5	137.1	140.4	143.2	146.1
		10	12.3	TC	176.02	163.46	150.91	140.58	130.54	120.51	111.45	103.49	95.53
				LDB	120.5	124.7	129.0	131.8	135.3	138.7	141.9	144.6	147.4
4	160	8	7.4	TC	168.88	154.83	140.78	134.36	123.18	111.99	105.56	96.77	87.98
				LDB	117.2	120.8	124.4	127.8	130.5	133.2	136.5	138.5	140.5
		10	11.0	TC	174.38	159.86	145.35	137.32	125.88	114.45	107.09	98.17	89.25
				LDB	119.7	123.1	126.5	129.7	132.2	134.8	137.9	139.8	141.6
		12	15.2	TC	178.08	163.25	148.42	139.28	127.68	116.08	108.09	99.08	90.08
				LDB	121.4	124.6	127.9	131.0	133.4	135.8	138.8	140.6	142.4
	180	8	7.4	TC	197.33	183.27	169.20	156.94	145.74	134.54	123.26	114.46	105.66
				LDB	130.2	133.8	137.4	142.5	145.2	147.9	152.7	154.7	156.6
		10	11.0	TC	203.72	189.18	174.65	160.37	148.92	137.47	125.02	116.10	107.17
				LDB	133.1	136.5	139.9	144.8	147.3	149.8	154.3	156.2	158.0
		12	15.2	TC	208.00	193.15	178.31	162.63	151.02	139.41	126.18	117.17	108.16
				LDB	135.1	138.3	141.5	146.2	148.7	151.1	155.4	157.2	158.9
5 (High Capacity)	160	8	6.5	TC	185.94	170.47	155.00	146.24	134.06	121.89	113.31	103.88	94.44
				LDB	125.0	127.9	130.9	135.5	137.6	139.6	143.6	145.0	146.4
		10	9.6	TC	192.12	176.13	160.14	149.33	136.90	124.46	114.78	105.21	95.65
				LDB	127.8	130.5	133.2	137.5	139.4	141.3	145.0	146.2	147.5
		12	13.4	TC	196.22	179.89	163.55	151.34	138.74	126.13	115.71	106.08	96.43
				LDB	129.7	132.3	134.8	138.9	140.6	142.4	145.8	147.0	148.2
	180	8	6.5	TC	217.25	201.76	186.28	170.80	158.61	146.43	132.30	122.86	113.41
				LDB	139.3	142.3	145.2	151.6	153.6	155.6	161.0	162.4	163.7
		10	9.6	TC	224.44	208.43	192.42	174.38	161.93	149.49	133.99	124.42	114.86
				LDB	142.6	145.3	148.0	153.9	155.8	157.6	162.5	163.8	165.0
		12	13.4	TC	229.18	212.83	196.47	176.71	164.09	151.48	135.07	125.43	115.78
				LDB	144.8	147.3	149.8	155.4	157.2	158.9	163.5	164.7	165.9

LEGEND

- EDB — Entering Dry Bulb (F)
- EWT — Entering Water Temperature (F)
- LDB — Leaving Dry Bulb (F)
- PD — Water Pressure Drop (ft)
- TC — Total Capacity (1000 Btuh)

NOTE: The maximum entering hot water temperature is 200 F. Customer must ensure that water vaporization does not occur, especially at higher elevations when entering hot water temperature is greater than 190 F.



HEATING CAPACITY — STEAM COILS

UNIT 40UV,UH	COIL ROWS	NOM. AIRFLOW (cfm)	ENTERING-AIR TEMPERATURE (F db)									
			-20		-10		0		10		20	
			TTL MBH	LAT (F)	TTL MBH	LAT (F)	TTL MBH	LAT (F)	TTL MBH	LAT (F)	TTL MBH	LAT (F)
050*	1	500	49.5	71.0	47.4	77.0	45.3	83.0	43.3	89.0	41.2	96.0
	2	500	69.8	108.0	66.9	113.0	64.0	117.0	61.0	122.0	58.2	127.0
075	1	750	67.4	61.0	63.8	67.0	60.2	74.0	56.6	80.0	53.3	87.0
	2	750	107.5	110.0	102.2	114.0	97.0	119.0	91.7	123.0	86.6	128.0
100	1	1000	89.8	61.0	85.0	67.0	80.2	74.0	56.6	80.0	53.3	87.0
	2	1000	143.3	110.0	136.3	114.0	129.1	119.0	122.2	123.0	115.4	128.0
125	1	1250	112.3	61.0	106.3	67.0	100.3	74.0	94.6	80.0	88.8	87.0
	2	1250	179.0	110.0	170.4	114.0	161.5	119.0	152.6	123.0	144.2	128.0
150	1	1500	134.9	61.0	127.7	67.0	120.5	74.0	113.5	80.0	106.6	87.0
	2	1500	214.8	110.0	204.5	114.0	193.7	119.0	183.1	123.0	173.3	128.0
200†	1	2000	153.6	51.0	147.1	58.0	140.8	65.0	134.3	72.0	127.6	79.0
	2	2000	248.5	95.0	238.0	110.0	227.9	105.0	217.4	110.0	206.4	115.0

UNIT 40UV,UH	COIL ROWS	NOM. AIRFLOW (cfm)	ENTERING-AIR TEMPERATURE (F db)									
			30		40		50		60		70	
			TTL MBH	LAT (F)	TTL MBH	LAT (F)	TTL MBH	LAT (F)	TTL MBH	LAT (F)	TTL MBH	LAT (F)
050*	1	500	39.2	102.0	37.0	108.0	35.0	114.0	32.9	120.0	30.9	127.0
	2	500	55.2	132.0	52.3	136.0	49.4	141.0	46.5	145.0	43.6	150.0
075	1	750	50.2	94.0	46.8	100.0	43.7	107.0	40.8	113.0	37.7	120.0
	2	750	81.6	132.0	76.8	137.0	71.8	142.0	67.0	146.0	62.4	151.0
100	1	1000	66.7	94.0	62.4	100.0	58.3	107.0	54.2	113.0	50.2	120.0
	2	1000	108.7	132.0	102.2	137.0	95.8	142.0	89.3	146.0	83.0	151.0
125	1	1250	83.5	94.0	78.0	100.0	73.0	107.0	67.9	113.0	62.6	120.0
	2	1250	135.8	132.0	127.9	137.0	119.8	142.0	111.6	146.0	103.2	151.0
150	1	1500	100.3	94.0	93.6	100.0	87.6	107.0	81.6	113.0	75.1	120.0
	2	1500	162.7	132.0	153.6	137.0	143.8	142.0	133.9	146.0	124.8	151.0
200†	1	2000	121.5	86.0	115.0	93.0	108.3	100.0	102.0	107.0	95.7	114.0
	2	2000	196.4	121.0	186.0	126.0	175.1	131.0	164.9	136.0	154.7	141.0

LEGEND
db — Dry Bulb
LAT — Leaving-Air Temperature
TTL MBH — Total Heating, Btuh x 1000

*40UV only.
 †40UH only.
 NOTE: Ratings based on 2 psig steam pressure. See table below for steam pressure and temperature correction factors. Maximum steam pressure is 6 psig at coil inlet.

STEAM CAPACITY CORRECTION FACTORS

STEAM PRESSURE (psig)	SATURATED TEMP (F)	LATENT HEAT (Btuh/lb)	ENTERING-AIR TEMPERATURE (F)										
			-20	-10	0	10	20	30	40	50	60	70	
0	212.0	970.3	0.97	0.97	0.97	0.96	0.97	0.97	0.97	0.97	0.96	0.96	0.96
2	218.5	966.2	1.00	1.00	1.00	1.00	1.00	1.00	1.00	1.00	1.00	1.00	1.00
5	227.1	960.6	1.02	1.03	1.03	1.03	1.04	1.05	1.05	1.05	1.05	1.05	1.05

NOTE: Standard steam pressure and temperature is 2 psig and 0° F. For all other temperatures and pressures, multiply heating capacity (TTL MBH) as found in 0° F entering air temperature column in Heating Capacity-Steam Coils table by correction factor shown.

$$LAT = \frac{(TTL \text{ MBH}) \times 1000}{1.082 \times \text{Nominal Airflow}} + \text{EAT (Entering-Air Temperature)}$$

Performance data (cont)



UNIT VENTILATOR AIRFLOW PSC MOTOR — SIZE 050-150*

FACTORY SETTINGS — CHILLED WATER COIL APPLICATIONS								
Unit	Speed	Approximate Air Delivery (CFM)						
		1-row	2-row	3-row	4-row	5-row	6-row	7-row
40UV050	High	522	510	497	485	490	489	457
	Medium	503	490	476	464	473	476	444
	Low	458	449	440	425	452	455	430
40UV,UH075	High	806	778	750	747	766	732	697
	Medium	682	664	645	629	621	596	570
	Low	569	554	539	527	533	514	495
40UV,UH100	High	1064	1033	1001	1013	973	980	967
	Medium	662	659	655	642	763	740	717
	Low	530	519	507	503	498	501	504
40UV,UH125	High	1295	1285	1215	1218	1239	1250	1175
	Medium	899	930	876	865	852	846	846
	Low	568	616	597	570	568	558	573
40UV,UH150	High	1542	1480	1500	1484	1468	1482	1374
	Medium	1071	1068	1065	1034	1033	1031	1013
	Low	812	801	790	881	848	842	799

FACTORY SETTINGS — ELECTRIC HEAT/DX COIL APPLICATIONS								
Unit	Speed	Approximate Air Delivery (CFM)						
		1-row	2-row	3-row	4-row	5-row	6-row	7-row
40UV050	High	522	510	497	485	490	489	457
	Medium	503	490	476	464	452	455	430
	Low	458	449	440	425	410	414	406
40UV,UH075	High	806	778	750	747	766	732	697
	Medium	682	664	645	629	621	596	570
	Low	569	554	539	527	533	514	495
40UV,UH100	High	1064	1033	1001	1013	973	980	967
	Medium	794	788	782	773	857	834	810
	Low	662	659	655	642	628	620	611
40UV,UH125	High	1295	1285	1215	1218	1239	1250	1175
	Medium	1055	1040	1024	995	1099	1091	1052
	Low	738	767	732	719	987	986	964
40UV,UH150	High	1542	1480	1500	1484	1468	1482	1374
	Medium	1285	1257	1229	1248	1246	1239	1199
	Low	934	928	922	901	1033	1031	1013

LEGEND

- CX** — Chilled Water Applications
- DX** — Direct Expansion
- HW** — Hot Water

*Standard on sizes 050-150.

NOTE: Use the table below to determine the heating and cooling coil combinations available with PSC (Permanent Split Capacitor) Motor operation.

COOLING COIL	HEATING COIL		
	HW	Steam	Electric
5 Rows CW	1 or 2 rows	N/A	3 elements
4 Rows CW or DX†	3 rows	1 or 2 rows	4 elements
3 Rows CW	4 rows	1 or 2 rows	5 or 6 elements

†DX cooling applications are only available in 4-row cooling configuration.



UNIT VENTILATOR AIRFLOW (cont)
ECM — SIZE 050-200

UNIT SIZE	MOTOR HP	COIL TYPE	APPROXIMATE AIR DELIVERY (Cfm)											
			ESP Speed Board Position											
			Low Position (0.0 in. wg)			Med Position (0.10 in. wg)			High Position (0.25 in. wg)			Max Position (0.45 in. wg)		
			High	Medium	Low	High	Medium	Low	High	Medium	Low	High	Medium	Low
40UV050	1/3	CW	499	336	248	—	—	—	—	—	—	—	—	—
		3-4EH/DX	499	419	336	—	—	—	—	—	—	—	—	—
		5-6EH	491	380	324	—	—	—	—	—	—	—	—	—
40UV,UH075	1/3	CW	747	484	346	753	548	432	752	530	427	751	541	386
		3-4EH/DX	747	644	498	753	609	472	752	612	470	751	618	498
		5-6EH	755	645	583	746	598	539	755	585	554	765	610	542
40UV,UH100	1/3	CW	997	703	505	987	693	543	1012	663	483	994	692	480
		3-4EH/DX	997	853	615	987	850	639	1012	823	626	994	819	618
		5-6EH	1016	819	719	1002	851	709	1024	798	787	1024	820	734
40UV,UH125	1/2	CW	1266	880	657	1239	905	609	1235	898	676	1231	898	627
		3-4EH/DX	1266	1023	769	1239	1055	758	1235	1037	765	1231	1010	778
		5-6EH	1259	1049	897	1239	995	888	1226	995	888	1253	994	919
40UV,UH150	1/2	CW	1503	1033	775	1479	1046	712	1494	1020	770	1486	1075	737
		3-4EH/DX	1503	1246	956	1479	1216	965	1494	1209	927	1486	1222	917
		5-6EH	1517	1222	1068	1490	1206	1087	1498	1159	1120	1503	1188	1074
40UH200*	3/4	ALL	2014	1384	1023	1981	1386	971	1965	1385	997	1814	1354	993

LEGEND

* Standard on size 200.

- 3-4EH/DX** — Direct Expansion Coil Applications with 3 to 4 Elements of Electric Heat
5-6EH — 5 to 6 Elements of Electric Heat Applications
CW — Chilled Water Applications
ECM — Electronically Commutated Motor
ESP — External Static Pressure

NOTES:

1. Factory default is Low Position.
2. Med, High, and Max positions are field settings.

SOUND POWER DATA
SOUND DATA FREE DELIVERY (dB)

40UV,UH UNIT SIZE	SWITCH SETTING	ACTUAL CFM	OCTAVE BAND FREQUENCY (Hz)						
			125	250	500	1000	2000	4000	8000
050	High	497	68.0	55.0	52.2	53.0	50.5	44.9	36.9
	Medium	476	62.9	54.2	50.6	51.8	49.1	43.3	34.7
	Low	440	58.9	52.6	48.9	49.9	46.6	40.3	31.2
075	High	750	60.0	55.5	57.6	54.5	50.1	45.2	35.6
	Medium	645	55.3	51.1	51.1	50.0	44.9	38.0	26.9
	Low	539	53.8	47.2	46.5	45.4	39.1	30.2	18.7
100	High	1001	61.5	55.7	57.2	55.5	50.9	47.3	38.5
	Medium	655	53.6	46.5	47.2	44.8	37.5	30.4	21.4
	Low	507	48.8	41.5	41.0	37.4	27.7	18.3	16.9
125	High	1215	67.4	57.4	59.3	56.4	52.1	48.0	38.6
	Medium	876	61.7	49.1	49.3	47.5	41.4	34.4	23.9
	Low	597	51.8	42.7	37.3	32.6	21.7	11.1	16.3
150	High	1500	73.9	62.2	67.4	59.8	56.9	53.4	46.3
	Medium	1065	62.7	53.0	55.2	51.2	45.4	39.1	28.7
	Low	790	54.8	48.5	45.5	43.1	34.2	25.3	15.5
200	High	1961	78.8	73.4	71.6	68.3	65.9	62.5	55.7
	Medium	1340	71.3	66.3	65.0	60.6	56.8	51.4	43.7
	Low	928	64.2	60.6	60.7	53.0	46.9	39.9	34.8

NOTES:

1. These noise ratings are rated in accordance with AHRI Standard 350.
2. Sound power levels were recorded using ANSI S12.32 method.
3. All sound ratings are based on 3 row coil except size 200, which is based on 4 row coil. Sound power is in decibels re 10e-12 w.
4. Sound power not relevant for ducted units.

Electrical data



UNITS WITHOUT ELECTRIC HEAT MOTOR DATA

PSC MOTORS						
UNIT 40UV,UH SIZE	MOTOR Hp	VOLTAGE	FLA	MCA	MOP (Amps)	MAX FUSE SIZE (Amps)
050*	1/5	115	3.7	4.6	8.3	15
		208/230	2.0	2.5	4.5	15
		265	1.6	2.0	3.6	15
075	1/5	115	3.7	4.6	8.3	15
		208/230	2.0	2.5	4.5	15
		265	1.6	2.0	3.6	15
100	1/5	115	3.7	4.6	8.3	15
		208/230	2.0	2.5	4.5	15
		265	1.6	2.0	3.6	15
125	1/5	115	3.7	4.6	8.3	15
		208/230	2.0	2.5	4.5	15
		265	1.6	2.0	3.6	15
150	1/5	115	3.7	4.6	8.3	15
		208/230	2.0	2.5	4.5	15
		265	1.6	2.0	3.6	15

ECM						
UNIT 40UV,UH SIZE	MOTOR Hp	VOLTAGE	FLA	MCA	MOP (Amps)	MAX FUSE SIZE (Amps)
050*	1/3	115	1.4	1.8	3.1	15
		208/230	1.3	1.6	2.9	15
		265	1.1	1.4	2.6	15
075	1/3	115	3.7	4.6	8.3	15
		208/230	2.3	2.9	5.1	15
		265	2.0	2.5	4.5	15
100	1/3	115	4.0	5.0	9.1	15
		208/230	2.6	3.2	5.8	15
		265	2.3	2.9	5.1	15
125	1/2	115	4.7	5.9	10.6	15
		208/230	3.3	4.1	7.4	15
		265	2.9	3.6	6.6	15
150	1/2	115	4.7	5.9	10.6	15
		208/230	3.3	4.1	7.4	15
		265	2.9	3.6	6.6	15
200†	3/4	115	9.6	12.0	21.6	20
		208/230	6.8	8.5	15.3	15
		265	5.5	6.9	12.4	15

LEGEND

- ECM** — Electronically Commutated Motor
- FLA** — Full Load Amps
- MCA** — Minimum Circuit Amps
- MOP** — Maximum Overload Protection
- PSC** — Permanent Split Capacitor

*Available in vertical configuration only.

†Available in horizontal configuration only.



**UNITS WITH ELECTRIC HEAT
PSC MOTOR AND ELECTRIC HEATER DATA**

UNIT	HP	NOMINAL V/Ph/Hz	NUMBER OF ELEMENTS	FLA	LAT (F)	MCA	MOCPP	TOTAL CAPACITY (kW)
40UV050 (at 500 Cfm)	1/5	208/1/60	3	17.2	90	21.5	25	3.2
			4	22.2	97	27.8	30	4.2
			5	27.3	104	34.1	35	5.3
			6	32.3	110	40.4	45	6.3
		240/1/60	3	19.5	97	24.4	25	4.2
			4	25.3	106	31.7	35	5.6
			5	31.2	115	39.0	40	7.0
			6	37.0	124	46.3	50	8.4
		277/1/60	3	16.8	97	21.0	25	4.2
			4	21.8	106	27.3	30	5.6
			5	26.9	115	33.6	35	7.0
			6	31.9	124	39.9	40	8.4
		208/3/60	3	10.8	90	13.5	15	3.2
			4	15.8	97	19.8	20	4.2
			5	19.5	104	24.4	25	5.3
			6	19.5	110	24.4	25	6.3
		240/3/60	3	12.1	97	15.1	20	4.2
			4	17.9	106	22.4	25	5.6
			5	22.2	115	27.8	30	7.0
			6	22.2	124	27.8	30	8.4
		460/3/60	3	6.0	97	7.5	15	4.2
			4	8.9	106	11.1	15	5.6
			5	11.0	115	13.8	15	7.0
			6	11.0	124	13.8	15	8.4

UNIT	HP	NOMINAL V/Ph/Hz	NUMBER OF ELEMENTS	FLA	LAT (F)	MCA	MOCPP	TOTAL CAPACITY (kW)
40UV,UH075 (at 750 Cfm)	1/5	208/1/60	3	23.7	89	29.6	30	4.5
			4	30.9	96	38.6	40	6.0
			5	38.1	102	47.6	50	7.5
			6	45.3	108	56.7	60	9.0
		240/1/60	3	27.0	96	33.8	35	6.0
			4	35.3	104	44.2	45	8.0
			5	43.7	113	54.6	60	10.0
			6	52.0	121	65.0	70	12.0
		277/1/60	3	23.3	96	29.1	30	6.0
			4	30.5	104	38.1	40	8.0
			5	37.7	113	47.1	50	10.0
			6	44.9	121	56.2	60	12.0
		208/3/60	3	14.5	89	18.2	20	4.5
			4	21.7	96	27.2	30	6.0
			5	27.0	102	33.8	35	7.5
			6	27.0	108	33.8	35	9.0
		240/3/60	3	16.5	96	20.6	25	6.0
			4	24.8	104	31.0	35	8.0
			5	30.9	113	38.6	40	10.0
			6	30.9	121	38.6	40	12.0
		460/3/60	3	8.2	96	10.2	15	6.0
			4	12.3	104	15.4	20	8.0
			5	15.4	113	19.2	20	10.0
			6	15.4	121	19.2	20	12.0

LEGEND

- ECM — Electronically Commutated Motor
- FLA — Full Load Amps
- LAT — Leaving-Air Temperature at 70 F Entering-Air Temperature
- MCA — Unit Minimum Circuit Ampacity
- MOCPP — Maximum Overcurrent Protection (Maximum Fuse Size or Circuit Breaker Amps)
- PSC — Permanent Split Capacitor

*Cooling coil must be on left-hand coil connection only.

NOTES:

1. LAT (leaving air temperature) is at maximum fan speed with entering air temperature of 70 F.
2. Face and bypass units are available only with 3 elements. Cooling coil must be on left-hand coil connection only.
3. Electric heat is available in the reheat only.

Electrical data (cont)



UNITS WITH ELECTRIC HEAT (cont) PSC MOTOR AND ELECTRIC HEATER DATA (cont)

UNIT	HP	NOMINAL V/Ph/Hz	NUMBER OF ELEMENTS	FLA	LAT (F)	MCA	MOCP	TOTAL CAPACITY (kW)
40UV,UH100 (at 1000 Cfm)	1/5	208/1/60	3	30.9	89	38.6	40	6.0
			4	40.5	95	50.7	60	8.0
			5	50.2	102	62.7	70	10.0
			6	59.8	108	74.7	80	11.9
		240/1/60	3	35.3	96	44.2	45	8.0
			4	46.5	104	58.1	60	10.7
			5	57.6	112	72.0	80	13.3
			6	68.7	121	85.8	90	16.0
		277/1/60	3	30.5	96	38.1	40	8.0
			4	40.1	104	50.1	60	10.7
			5	49.7	112	62.2	70	13.3
			6	59.4	121	74.2	80	16.0
		208/3/60	3	18.7	89	23.4	25	6.0
			4	28.3	95	35.4	40	8.0
			5	35.4	102	44.3	45	10.0
			6	35.4	108	44.3	45	11.9
		240/3/60	3	21.3	96	26.6	30	8.0
			4	32.4	104	40.5	45	10.7
			5	40.5	112	50.7	60	13.3
			6	40.5	121	50.7	60	16.0
		460/3/60	3	10.6	96	13.2	15	8.0
			4	16.1	104	20.1	25	10.7
			5	20.2	112	25.2	30	13.3
			6	20.2	121	25.2	30	16.0

UNIT	HP	NOMINAL V/Ph/Hz	NUMBER OF ELEMENTS	FLA	LAT (F)	MCA	MOCP	TOTAL CAPACITY (kW)
40UV,UH125 (at 1250 Cfm)	1/5	208/1/60	3	38.1	89	47.6	50	7.5
			4	50.1	96	62.7	70	10.0
			5	62.2	102	77.7	80	12.5
			6*	74.2	108	92.8	100	15.0
		240/1/60	3	43.7	96	54.6	60	10.0
			4	57.6	104	71.9	80	13.3
			5	71.4	113	89.3	90	16.7
			6*	85.3	121	106.7	110	20.0
		277/1/60	3	37.7	96	47.1	50	10.0
			4	49.7	104	62.2	70	13.3
			5	61.8	113	77.2	80	16.7
			6*	73.8	121	92.2	100	20.0
		208/3/60	3	22.9	89	28.6	30	7.5
			4	34.9	96	43.6	45	10.0
			5	43.7	102	54.7	60	12.5
			6*	43.7	108	54.7	60	15.0
		240/3/60	3	26.1	96	32.6	35	10.0
			4	40.0	104	50.0	50	13.3
			5	50.2	113	62.7	70	16.7
			6*	50.2	121	62.7	70	20.0
		460/3/60	3	13.0	96	16.2	20	10.0
			4	19.9	104	24.9	25	13.3
			5	25.0	113	31.3	35	16.7
			6*	25.0	121	31.3	35	20.0

LEGEND

ECM	—	Electronically Commutated Motor
FLA	—	Full Load Amps
LAT	—	Leaving-Air Temperature at 70 F Entering-Air Temperature
MCA	—	Unit Minimum Circuit Ampacity
MOCP	—	Maximum Overcurrent Protection (Maximum Fuse Size or Circuit Breaker Amps)
PSC	—	Permanent Split Capacitor

*Cooling coil must be on left-hand coil connection only.

NOTES:

- LAT (leaving air temperature) is at maximum fan speed with entering air temperature of 70 F.
- Face and bypass units are available only with 3 elements. Cooling coil must be on left-hand coil connection only.
- Electric heat is available in the reheat only.



UNITS WITH ELECTRIC HEAT (cont)
PSC MOTOR AND ELECTRIC HEATER DATA (cont)

UNIT	HP	NOMINAL V/Ph/Hz	NUMBER OF ELEMENTS	FLA	LAT (F)	MCA	MOCP	TOTAL CAPACITY (kW)
40UV.UH150 (at 1500 Cfm)	1/5	208/1/60	3	45.3	89	56.7	60	9.0
			4	59.8	96	74.7	80	12.0
			5	74.2	102	92.8	100	15.0
			6*	88.7	108	110.8	125	18.0
		240/1/60	3	52.0	96	65.0	70	12.0
			4	68.7	104	85.8	90	16.0
			5	85.3	113	106.7	110	20.0
			6	—	—	—	—	—
		277/1/60	3	44.9	96	56.2	60	12.0
			4	59.4	104	74.2	80	16.0
			5	73.8	113	92.3	100	20.0
			6	—	—	—	—	—
		208/3/60	3	27.0	89	33.8	35	9.0
			4	41.5	96	51.9	60	12.0
			5	52.1	102	65.1	70	15.0
			6*	52.1	108	65.1	70	18.0
		240/3/60	3	30.9	96	38.6	40	12.0
			4	47.6	104	59.5	60	16.0
			5	59.8	113	74.8	80	20.0
			6*	59.8	121	74.8	80	24.0
		460/3/60	3	15.4	96	19.2	20	12.0
			4	23.7	104	29.6	30	16.0
			5	29.8	113	37.3	40	20.0
			6*	29.8	121	37.3	40	24.0

LEGEND

- FLA** — Full Load Amps
- LAT** — Leaving-Air Temperature at 70 F Entering-Air Temperature
- MCA** — Unit Minimum Circuit Ampacity
- MOCP** — Maximum Overcurrent Protection (Maximum Fuse Size or Circuit Breaker Amps)
- PSC** — Permanent Split Capacitor

*Cooling coil must be on left-hand coil connection only.

NOTES:

1. LAT (leaving air temperature) is at maximum fan speed with entering air temperature of 70 F.
2. Face and bypass units are available only with 3 elements. Cooling coil must be on left-hand coil connection only.
3. Electric heat is available in the reheat only.

Electrical data (cont)



UNITS WITH ELECTRIC HEAT (cont) ECM AND ELECTRIC HEATER DATA

UNIT	HP	NOMINAL V/Ph/Hz	NUMBER OF ELEMENTS	FLA	LAT (F)	MCA	MOCP	TOTAL CAPACITY (kW)
40UV050 (at 500 Cfm)	1/3	208/1/60	3	16.5	90	20.6	25	3.2
			4	21.5	97	26.9	30	4.2
			5	26.6	104	33.2	35	5.3
			6	31.6	110	39.5	40	6.3
		240/1/60	3	18.8	97	23.5	25	4.2
			4	24.6	106	30.8	35	5.6
			5	30.5	115	38.1	40	7.0
			6	36.3	124	45.4	50	8.4
		277/1/60	3	16.3	97	20.3	25	4.2
			4	21.3	106	26.6	30	5.6
			5	26.4	115	33.0	35	7.0
			6	31.4	124	39.3	40	8.4
		208/3/60	3	10.1	90	12.6	15	3.2
			4	15.1	97	18.9	20	4.2
			5	18.8	104	23.5	25	5.3
			6	18.8	110	23.5	25	6.3
		240/3/60	3	11.4	97	14.3	15	4.2
			4	17.2	106	21.6	25	5.6
			5	21.5	115	26.9	30	7.0
			6	21.5	124	26.9	30	8.4
		460/3/60	3	5.4	97	6.8	15	4.2
			4	8.3	106	10.4	15	5.6
			5	10.5	115	13.1	15	7.0
			6	10.5	124	13.1	15	8.4

UNIT	HP	NOMINAL V/Ph/Hz	NUMBER OF ELEMENTS	FLA	LAT (F)	MCA	MOCP	TOTAL CAPACITY (kW)
40UV,UH075 (at 750 Cfm)	1/3	208/1/60	3	24.0	89	30.0	30	4.5
			4	31.2	96	39.0	40	6.0
			5	38.4	102	48.0	50	7.5
			6	45.6	108	57.0	60	9.0
		240/1/60	3	27.3	96	34.1	35	6.0
			4	35.6	104	44.5	45	8.0
			5	44.0	113	55.0	60	10.0
			6	52.3	121	65.4	70	12.0
		277/1/60	3	23.7	96	29.6	30	6.0
			4	30.9	104	38.6	40	8.0
			5	38.1	113	47.6	50	10.0
			6	45.3	121	56.7	60	12.0
		208/3/60	3	14.8	89	18.5	20	4.5
			4	22.0	96	27.6	30	6.0
			5	27.3	102	34.2	35	7.5
			6	27.3	108	34.2	35	9.0
		240/3/60	3	16.8	96	20.9	25	6.0
			4	25.1	104	31.4	35	8.0
			5	31.2	113	39.0	40	10.0
			6	31.2	121	39.0	40	12.0
		460/3/60	3	8.2	96	10.2	15	6.0
			4	12.3	104	15.4	20	8.0
			5	15.4	113	19.2	20	10.0
			6	15.4	121	19.2	20	12.0

LEGEND

- ECM — Electronically Commutated Motor
- FLA — Full Load Amps
- LAT — Leaving-Air Temperature at 70 F Entering-Air Temperature
- MCA — Unit Minimum Circuit Ampacity
- MOCP — Maximum Overcurrent Protection (Maximum Fuse Size or Circuit Breaker Amps)

*Cooling coil must be on left-hand coil connection only.

NOTES:

1. LAT (leaving air temperature) is at maximum fan speed with entering air temperature of 70 F.
2. Face and bypass units are available only with 3 elements. Cooling coil must be on left-hand coil connection only.
3. Electric heat is available in the reheat only.



UNITS WITH ELECTRIC HEAT (cont)
ECM AND ELECTRIC HEATER DATA (cont)

UNIT	HP	NOMINAL V/Ph/Hz	NUMBER OF ELEMENTS	FLA	LAT (F)	MCA	MOCP	TOTAL CAPACITY (kW)
40UV,UH100 (at 1000 Cfm)	$\frac{1}{3}$	208/1/60	3	31.5	89	39.4	40	6.0
			4	41.1	95	51.4	60	8.0
			5	50.8	102	63.4	70	10.0
			6	60.4	108	75.5	80	11.9
		240/1/60	3	35.9	96	44.9	45	8.0
			4	47.1	104	58.8	60	10.7
			5	58.2	112	72.7	80	13.3
			6	69.3	121	86.6	90	16.0
		277/1/60	3	31.2	96	39.0	40	8.0
			4	40.8	104	51.0	60	10.7
			5	50.4	112	63.1	70	13.3
			6	60.1	121	75.1	80	16.0
		208/3/60	3	19.3	89	24.1	25	6.0
			4	28.9	95	36.2	40	8.0
			5	36.0	102	45.0	50	10.0
			6	36.0	108	45.0	50	11.9
		240/3/60	3	21.9	96	27.3	30	8.0
			4	33.0	104	41.2	45	10.7
			5	41.1	112	51.4	60	13.3
			6	41.1	121	51.4	60	16.0
		460/3/60	3	10.6	96	13.3	15	8.0
			4	16.2	104	20.2	25	10.7
			5	20.3	112	25.3	30	13.3
			6	20.3	121	25.3	30	16.0

UNIT	HP	NOMINAL V/Ph/Hz	NUMBER OF ELEMENTS	FLA	LAT (F)	MCA	MOCP	TOTAL CAPACITY (kW)
40UV,UH125 (at 1250 Cfm)	$\frac{1}{2}$	208/1/60	3	39.4	89	49.3	50	7.5
			4	51.5	96	64.3	70	10.0
			5	63.5	102	79.4	80	12.5
			6*	75.5	108	94.4	100	15.0
		240/1/60	3	45.0	96	56.2	60	10.0
			4	58.9	104	73.6	80	13.3
			5	72.7	113	90.9	100	16.7
			6*	86.6	121	108.3	110	20.0
		277/1/60	3	39.0	96	48.7	50	10.0
			4	51.0	104	63.8	70	13.3
			5	63.1	113	78.8	80	16.7
			6*	75.1	121	93.9	100	20.0
		208/3/60	3	24.2	89	30.2	35	7.5
			4	36.2	96	45.3	50	10.0
			5	45.0	102	56.3	60	12.5
			6*	45.0	108	56.3	60	15.0
		240/3/60	3	27.4	96	34.2	35	10.0
			4	41.3	104	51.6	60	13.3
			5	51.5	113	64.3	70	16.7
			6*	51.5	121	64.3	70	20.0
		460/3/60	3	13.2	96	16.5	20	10.0
			4	20.2	104	25.2	30	13.3
			5	25.3	113	31.6	35	16.7
			6*	25.3	121	31.6	35	20.0

LEGEND

- ECM — Electronically Commutated Motor
- FLA — Full Load Amps
- LAT — Leaving-Air Temperature at 70 F Entering-Air Temperature
- MCA — Unit Minimum Circuit Ampacity
- MOCP — Maximum Overcurrent Protection (Maximum Fuse Size or Circuit Breaker Amps)

*Cooling coil must be on left-hand coil connection only.

NOTES:

1. LAT (leaving air temperature) is at max fan speed with entering air temperature of 70 F.
2. Face and bypass units are available only with 3 elements. Cooling coil must be on left-hand coil connection only.
3. Electric heat is available in the reheat only.

Electrical data (cont)



UNITS WITH ELECTRIC HEAT (cont) ECM AND ELECTRIC HEATER DATA (cont)

UNIT	HP	NOMINAL V/Ph/Hz	NUMBER OF ELEMENTS	FLA	LAT (F)	MCA	MOCP	TOTAL CAPACITY (kW)
40UV,UH150 (at 1500 Cfm)	1/2	208/1/60	3	46.7	89	58.3	60	9.0
			4	61.1	96	76.4	80	12.0
			5	75.6	102	94.4	100	15.0
			6*	90.0	108	112.5	125	18.0
		240/1/60	3	53.3	96	66.6	70	12.0
			4	70.0	104	87.5	90	16.0
			5	86.6	113	108.3	110	20.0
			6	—	—	—	—	—
		277/1/60	3	46.2	96	57.8	60	12.0
			4	60.7	104	75.8	80	16.0
			5	75.1	113	93.9	100	20.0
			6	—	—	—	—	—
		208/3/60	3	28.3	89	35.4	40	9.0
			4	42.8	96	53.5	60	12.0
			5	53.4	102	66.7	70	15.0
			6*	53.4	108	66.7	70	18.0
		240/3/60	3	32.2	96	40.3	45	12.0
			4	48.9	104	61.1	70	16.0
			5	61.1	113	76.4	80	20.0
			6*	61.1	121	76.4	80	24.0
		460/3/60	3	15.6	96	19.5	20	12.0
			4	24.0	104	30.0	30	16.0
			5	30.1	113	37.6	40	20.0
			6*	30.1	121	37.6	40	24.0

UNIT	HP	NOMINAL V/Ph/Hz	NUMBER OF ELEMENTS	FLA	LAT (F)	MCA	MOCP	TOTAL CAPACITY (kW)
40UH200 (at 2000 Cfm)	3/4	208/1/60	3	50.1	84	62.7	70	9.0
			4	64.6	89	80.7	90	12.0
			5	79.0	94	98.8	100	15.0
			6*	93.5	99	116.8	125	18.0
		240/1/60	3	56.8	89	71.0	80	12.0
			4	73.5	96	91.8	100	16.0
			5	90.1	102	112.7	125	20.0
			6	—	—	—	—	—
		277/1/60	3	48.8	89	61.0	70	12.0
			4	63.3	96	79.1	80	16.0
			5	77.7	102	97.1	100	20.0
			6	—	—	—	—	—
		208/3/60	3	31.8	84	39.8	40	9.0
			4	46.3	89	57.9	60	12.0
			5	56.9	94	71.1	80	15.0
			6*	56.9	99	71.1	80	18.0
		240/3/60	3	35.7	89	44.6	45	12.0
			4	52.4	96	65.5	70	16.0
			5	64.6	102	80.8	90	20.0
			6*	64.6	108	80.8	90	24.0
		460/3/60	3	16.9	89	21.1	25	12.0
			4	25.2	96	31.5	35	16.0
			5	31.3	102	39.1	40	20.0
			6*	31.3	108	39.1	40	24.0

LEGEND

ECM — Electronically Commutated Motor
FLA — Full Load Amps
LAT — Leaving-Air Temperature at 70 F Entering-Air Temperature
MCA — Unit Minimum Circuit Ampacity
MOCP — Maximum Overcurrent Protection (Maximum Fuse Size or Circuit Breaker Amps)

*Cooling coil must be on left-hand coil connection only.

NOTES:

- LAT (leaving air temperature) is at max fan speed with entering air temperature of 70 F.
- Face and bypass units are available only with 3 elements. Cooling coil must be on left-hand coil connection only.
- Electric heat is available in the reheat only.

Application data



General

A unit ventilator provides either heating, cooling, ventilating, mechanical cooling or economizer (natural) cooling by introducing outdoor air up to 100% of a unit's rated capacity.

Unit ventilators are used in schools, institutions, offices, meeting rooms, cafeterias, and other applications where the density of occupation requires controlled ventilation to meet local codes. Normally, the fan operates continuously in the occupied mode while the temperature of the unit discharge air varies in accordance with room requirements.

Control methods

Whether the unit configuration is a 2-pipe or 4-pipe system, the space temperature is maintained by controlling discharge air temperature by using one of two methods:

Face and bypass damper — The face and bypass damper controls room air and outdoor air mixtures by diverting the mixed air through or around the coil. The face and bypass damper aids in directing humid outdoor air through the cold coil to remove moisture. The air first passes through the cooling coil, where it is dehumidified because the coil surface is always below the dew point. After air passes through the cooling coil, it flows through the fan, where it is mixed with any bypass air.

Face and bypass damper control provides protection against coil freeze-up due to constant flow through the coil, which provides good dehumidification during the summer and minimizes freeze potential during the winter.

Valve control — Valve control uses a 2-way or 3-way modulating control valve to vary the water flow through the coil, thereby controlling temperature. The room air and outdoor air mixture always passes through the coil.

Both control methods simultaneously control a valve and damper or step controller to regulate the heat supply and an outdoor/return air damper. A sensor in the discharge air prevents the air temperature from falling below a desired minimum temperature (usually 53 to 55 F). Unit controls provide the proper sequences for the following stages:

Warm-up stage — Rapid warm-up allows the unit to generate full heat with the outdoor-air damper closed. Thus, 100% of room air is recirculated and heated until the room temperature approaches 3 degrees of the desired heating set point.

Heating and ventilating stage — As the room temperature rises into the operating range of the set point, the outdoor-air damper opens to provide minimum ventilation. As the room temperature continues to rise, the unit ventilator's heat supply is throttled (face and bypass or valve control).

Cooling and ventilating stage — When the room temperature rises above the desired level, the room thermostat throttles the heat supply so that cool air flows into the room. The control gradually shuts off the heat and opens the outdoor-air damper. The discharge air sensor can take control during this stage to keep the discharge temperature from falling below a set level.

The ASHRAE handbook describes three control cycles commonly used with unit ventilators. These apply only to heating, heating and ventilating, and natural cooling operations.

Cycle I — Outdoor-air damper is closed during warm-up. As the control system approaches set point, the outdoor-air damper is opened to admit 100% outdoor air.

Cycle II — Again, the outdoor-air damper is closed during warm-up. As the control system approaches set point, a minimum amount of outdoor air (normally 20% to 40%) is admitted during the heating and ventilating stage. This percentage is gradually increased to 100%, if needed, during the ventilation cooling stage. During the natural cooling stage, the heat source will be shut off to limit any radiant heat off the coil. This is accomplished with the modulating valve on a valve control unit or an end of cycle two-position valve and damper in a face and bypass controlled unit.

Cycle III — During warm-up, the outdoor-air damper is closed. As the control system approaches set point, a variable amount of outdoor air is admitted, as needed, to maintain a fixed air coil temperature entering the heating element (typically 55 to 60 F).

Unit ventilators typically include any of the three cycles described above in addition to a mechanical cooling stage (chilled water or DX), during which a fixed amount of outdoor air is introduced.

Indoor air quality (IAQ)

Indoor air quality awareness has raised concerns about health hazards in homes, offices, and schools. Better building construction, less infiltration, and more air recirculation — all steps that have been taken to reduce energy costs — have led to "sick building syndrome." Also of concern are fumes and vapors from plastic and synthetic materials used in construction today. In some areas of the country, radon levels present a problem.

A unit ventilator that provides controlled amounts of ventilation air as well as comfort air conditioning will significantly reduce the impact of the IAQ issues mentioned above.

Draft elimination (draft stop enclosure)

Cold window downdrafts are a common cause of discomfort for occupants of classrooms. Downdrafts occur in applications in which there are relatively large areas of glass and prolonged periods of cold outdoor temperatures.

Carrier's draft elimination system is the best system available to handle the downdraft problem. The draft elimination system intercepts the falling cold air at the window-sill level and re-circulates it back to the unit ventilator via the room air damper. The draft air then becomes part of the normal air circulation pattern. This method of draft elimination is accomplished by closing off the return-air grille on the front of the unit ventilator, which causes the air to be drawn in through the ends of the unit.

Application data (cont)



Window draft protection should be employed in areas where the following conditions exist:

- Window area exceeds 40% of the outside wall area
- Windows are single pane glass
- Outside temperatures are expected to be below 35 F for a significant portion of the occupied period.

The need for window draft protection is not always clear. To determine if the need exists, calculate the window heat loss at an outdoor temperature of 35 F. If the window heat loss exceeds 250 Btu per ft, draft protection is suggested.

Duct design

Typically, horizontal units (40UH) may have ducted supply arrangements. When the added resistance of the ductwork exceeds 0.09 in. wg, a high-static motor is required. The ECM motor used is adjustable for static ranges of 0.10 to 0.45 in. wg by using a jumper setting on the printed circuit board inside the unit control box.

Good duct system design is required to obtain satisfactory fan system performance. The impact of poor duct design results in lower airflow (cfm), noise, and vibration problems that cannot be overcome without major unit modifications. The connection between the unit fan inlet and outlet should provide a straight flow design or be as near to it as possible.

Use the following suggestions when designing ductwork. The ASHRAE handbook and AMCA publications also offer guidelines for duct design.

- The discharge duct must be the size of the unit discharge and opening. Insulation on the inside of the duct will require a larger duct size. Duct collars must not infringe on the discharge opening.

- The minimum straight length of the discharge duct must not be less than that shown in the table below. In order to reduce sound levels in the space, a minimum of 5 ft of straight duct should be used in both the discharge and return ducts.

When designing for sound considerations, some additional suggestions include:

- Make two ninety-degree turns in both the supply and return duct.
- Keep duct velocity low.
- Support the ductwork independent of the unit.
- Line the return air duct for 5 ft (from the unit).
- Locate the return away from the unit discharge.
- Provide multiple discharge grilles.
- Size the return air and outdoor air ducts to handle 100% of the total airflow (cfm) to accommodate both morning warm-up and economizer operation. This will avoid low entering-air volumes and the associated performance issues.

MINIMUM DUCT LENGTH

NOMINAL UNIT AIRFLOW (cfm)	STRAIGHT DUCT DISCHARGE (in.)
750	45
1000	52
1250	58
1500	63
2000	75

CEILING UNIT VENTILATOR RECOMMENDED DUCT DESIGN FOR SOUND ATTENUATION

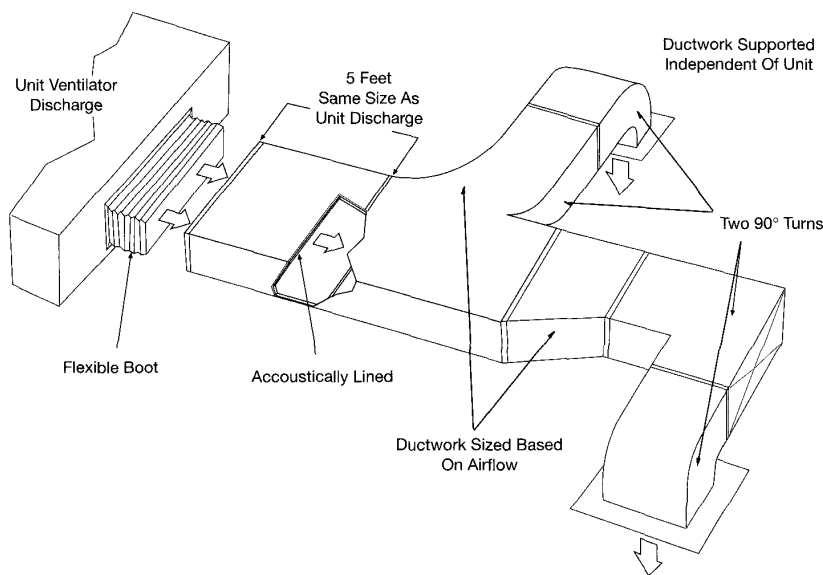

VERTICAL UNIT VENTILATOR TYPICAL APPLICATION WITH OUTDOOR AIR

16 5/8" Deep unit with open pipe tunnel and standard intake louver application.

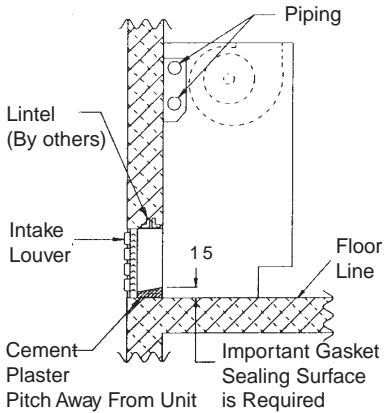

16 5/8" Deep unit with open pipe tunnel and high intake louver application with chased wall.

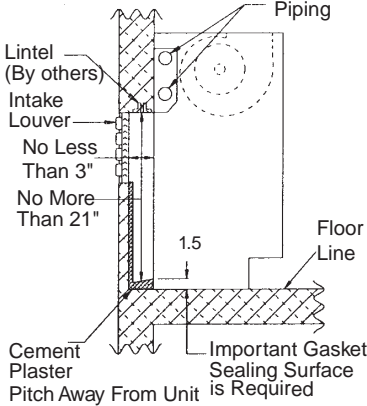

16 5/8" Deep unit with closed pipe tunnel and high intake louver application with chased wall.

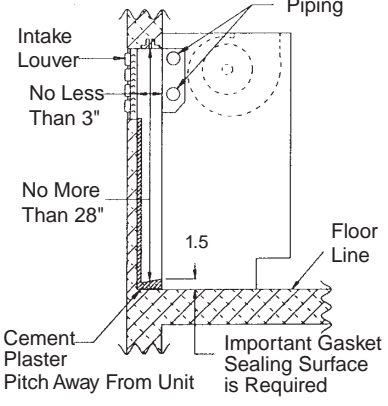

16 5/8" Deep unit with open pipe tunnel and floor outdoor air intake application.

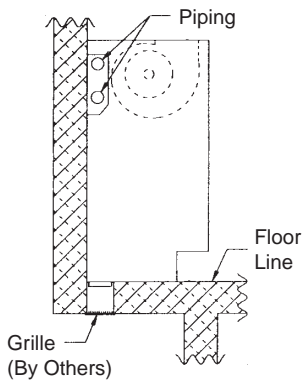

21 7/8" Deep adapter back unit with standard intake louver application.

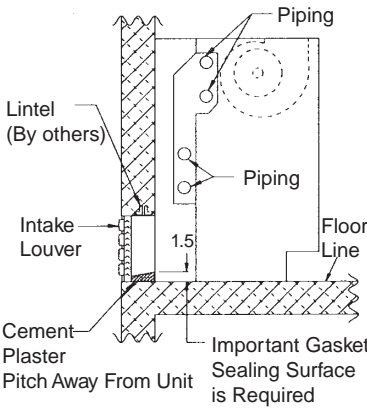

21 7/8" Deep adapter back unit with high intake louver application.

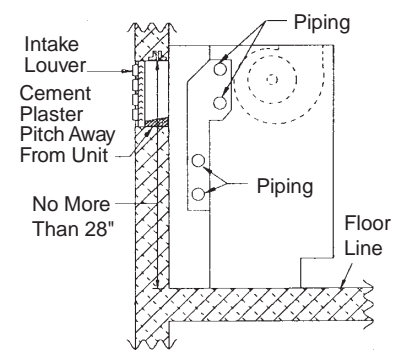

21 7/8" Deep pipe passage unit with standard intake louver application.

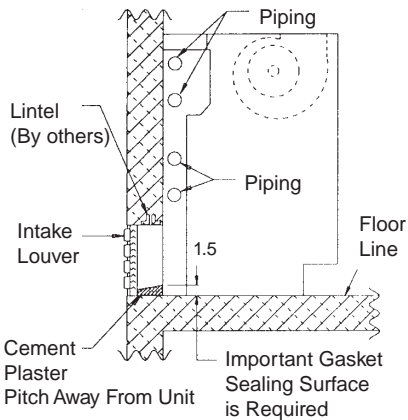

21 7/8" Deep window intake unit with window intake louver application.

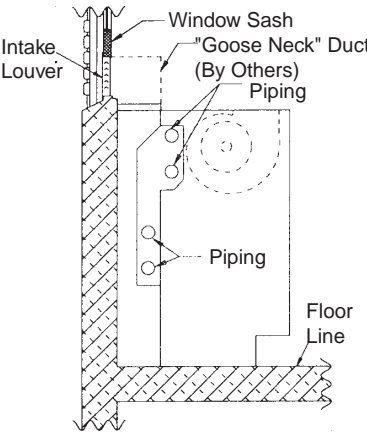

21 7/8" Deep adapter back unit with floor outdoor air intake application.

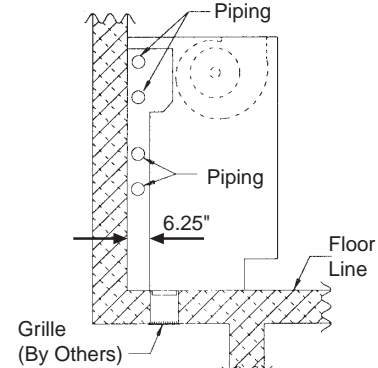

HORIZONTAL UNIT VENTILATOR TYPICAL APPLICATION WITH OUTDOOR AIR EXPOSED UNIT — BAR GRILLE

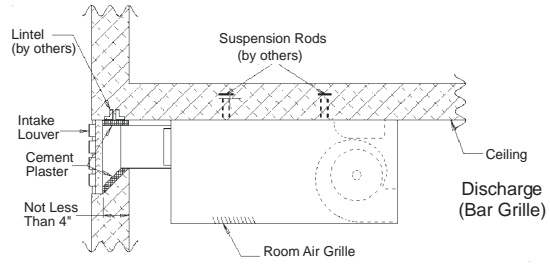
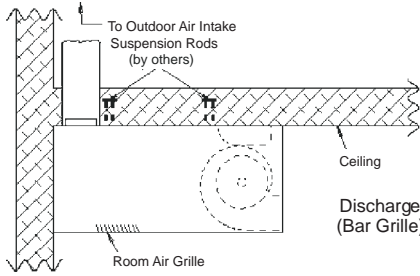

CONCEALED UNIT

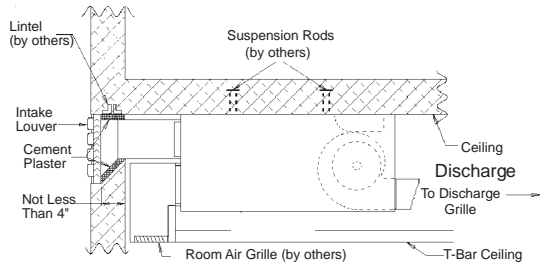
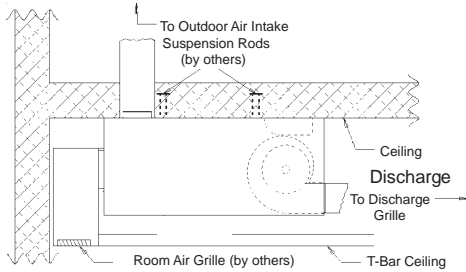

EXPOSED UNIT — DOUBLE DEFLECTION GRILLE

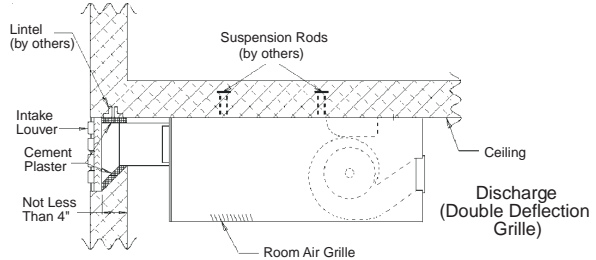
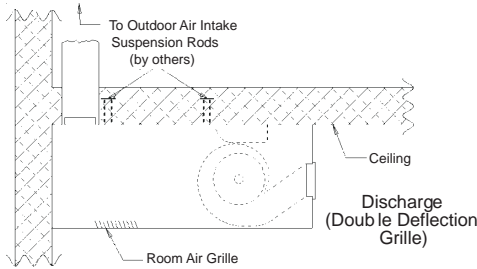

FULLY RECESSED UNIT — DOUBLE DEFLECTION GRILLE

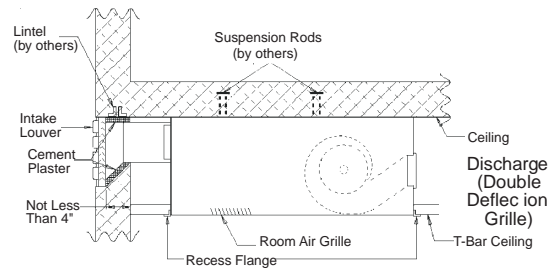
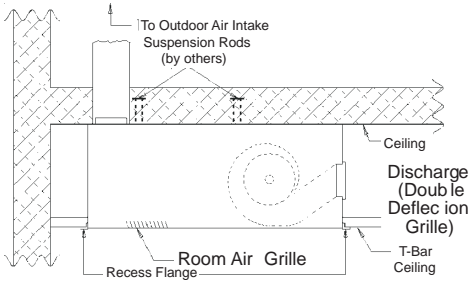

FULLY RECESSED UNIT — CURVED BLADE DISCHARGE GRILLE

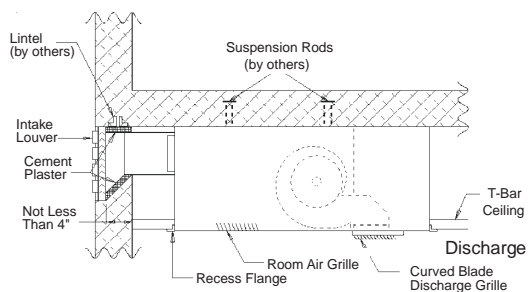
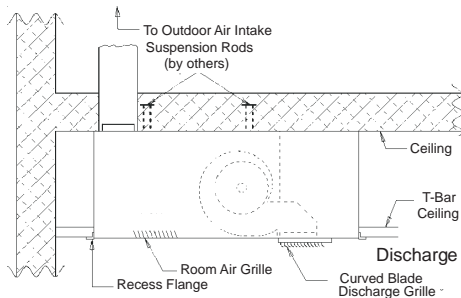

Water valves

Water valves can be either 2-way or 3-way. Hot water valves are piped normally open to the coil. Chilled water valves are piped normally closed to the coil.

On 2-pipe heat/cool applications, the valves are piped as though heating valves (normally open).

Piping packages are installed and tested in the Carrier factory to ensure proper operation and leak tightness. They are disconnected at the unions and shipped in the end compartments.

All water coils contain vent and drain plugs as standard. Control valve and all components by Carrier, unless otherwise indicated. **Valve packages must be field insulated if required by specification.**

TYPICAL VALVE PIPING FOR FACTORY-ASSEMBLED AND FIELD-INSTALLED

STEAM VALVE PACKAGE COMPONENTS

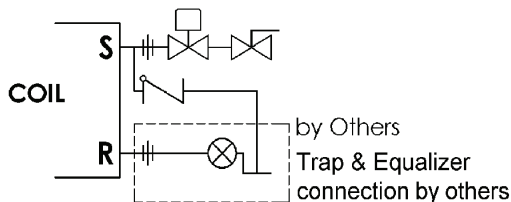

TWO-WAY VALVE PACKAGE COMPONENTS

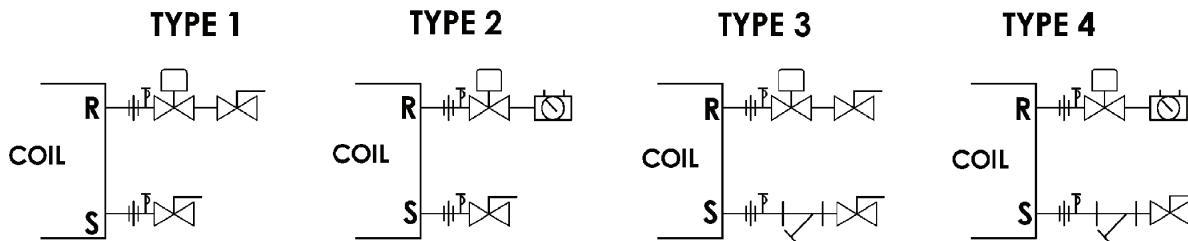

THREE-WAY VALVE PACKAGE COMPONENTS

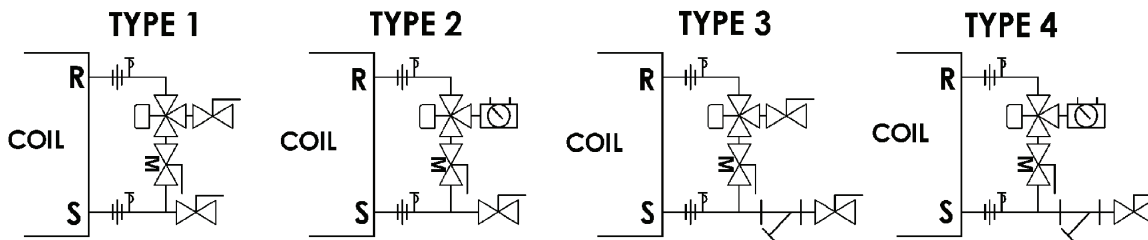

LEGEND

- | | | | |
|--|-----------------------------|--|---------------------|
| | BALL VALVE | | STEAM TRAP |
| | BALL VALVE
w/MEMORY STOP | | PT PORT |
| | CHECK VALVE | | UNION |
| | CIRCUIT SETTER | | 3-WAY CONTROL VALVE |
| | WYE STRAINER | | 2-WAY CONTROL VALVE |

Guide specifications



Unit Ventilator

HVAC Guide Specifications

Size Range: **500 to 1500 Rated Cfm Floor Units (Vertical)**
750 to 2000 Rated Cfm Ceiling (Horizontal)

Carrier Model Numbers:

40UV (Vertical)
40UH (Horizontal)

Part 1 — General

1.01 SYSTEM DESCRIPTION

Carrier unit ventilators are designed for floor (vertical) or ceiling (horizontal) mounting. Units shall incorporate chilled water or direct expansion cooling and hot water, steam or electric heat as specified. Units are available with Direct Digital Controls (DDC) that provide stand-alone operation or can be incorporated into Carrier's i-Vu® Open control system or a BACnet building automation system utilizing the factory-installed Carrier Unit Vent Open Controller. Indoor air quality is assured with dehumidification and ventilation options.

1.02 QUALITY ASSURANCE

- A. Units shall be tested and certified in accordance with AHRI Standard 840, latest edition.
- B. Unit shall be constructed and listed in accordance with ETL and ETL, Canada standards (ANSI/UL 1995-1999, second edition) (CAN/CSA C22.2 NO 236-95).
- C. Unit insulation and adhesive shall meet the requirements for flame spread rating of lower than 25 per ASTM E84 and smoke generation rating of lower than 50 per ASTM E84. Only closed cell insulation shall be used. The use of fiberglass insulation is not acceptable.
- D. Each coil shall be factory tested for leakage at 350 psig air pressure with coil submerged in water.

1.03 DELIVERY, STORAGE AND HANDLING

Units are secured to a heavy-duty wooden pallet, boxed, banded and labeled for shipment. Units must be stored and handled per manufacturer's recommendations.

Part 2 — Equipment

2.01 UNIT DESCRIPTION

A. General:

The unit shall be a factory-assembled bolt-together unit ventilator. Contained within the unit enclosure shall be factory-installed motor, wiring, blowers, coil(s), bearing, outdoor/return air damper, optional face/bypass damper and optional controls. Unit shall have a draw-thru design for uniform air distribution across the coil and even discharge temperatures.

B. Unit Construction:

1. Unit frame shall be constructed of heavy gage galvanized steel components that form a rigid foundation and resist corrosion.
2. Unit composed of three main sub-assembled modules: Blower Module, Coil Module and Damper Module. Modules shall be removable without disassembling the unit.
3. Modules shall be externally insulated using closed cell insulation.
4. Unit back shall be insulated using closed cell insulation.
5. Exterior access panels shall be constructed of heavy gage galvanized steel that has been cleaned and pretreated before painting to maximize corrosion resistance. Exterior service access panels shall be retained by tamper-resistant fasteners. Panels are electrostatically coated with polyester powder baked on textured paint.

C. 40UV (Vertical unit):

1. Unit standard depth of 16⁵/₈ in. (21⁷/₈ in. depth optional), 30-in. tall cabinet with three 16-gage exposed front panels, service access panels with tamper-resistant hex socket head threaded fasteners and retainer chains for safety and ease of service.
2. Cabinet models shall have standard textured baked powder finished panels. Cabinet tops shall be charcoal bronze with a steel bar-stock discharge grille. Cabinet top shall have textured charcoal finish.
3. External access panels shall be easily removed from outside of the unit for easy access to filters and routine maintenance. Unit top shall be easily removed for routine maintenance.
4. Unit shall include leveling legs to compensate for floor irregularities.

D. 40UH (Horizontal units):

1. Unit standard depth of 34 in. (39¹/₂ in. and 43¹/₂ in. depth optional; 200 size unit has standard depth of 43¹/₂ in. with an optional depth of 47¹/₂ in.), 16⁵/₈ in. tall cabinet with two exposed service access bottom panels, with tamper-resistant hex socket head threaded fasteners and retainer chains for safety and ease of service.
2. Rated 750 to 1500 cfm units shall have standard bar-stock steel linear discharge grille and optional screens with spaces no larger than 1/4 in. wide, anodized aluminum double deflection discharge grille or discharge duct collar only.
3. Rated 2000 cfm units shall have an anodized aluminum double deflection discharge grille or optional discharge duct collar.



4. Unit shall have two hinged bottom access panels for easy access to filters and routine maintenance.
5. Retaining chains shall be furnished for both panels to ensure maximum safety.

E. Coils:

1. Chilled water and combination chilled/hot water coils shall be constructed of mechanically expanded copper tubing, minimum wall 0.016 in. inside, aluminum fins, with a minimum thickness of 0.025 in. The fin surface shall be enhanced to the maximum degree by incorporated a raised lance design.
2. Hot water coils shall be constructed of mechanically expanded copper tubing with a minimum wall of 0.016 in., inside aluminum fins shall have a minimum thickness of 0.045 in. Coils shall have a factory-mounted low limit device mounted on the leaving side of the heating coil. The device shall be single-pole, double-throw and shall activate at 38 F if the capillary device senses a temperature change along any 6 in. of the device.
3. Direct expansion (DX) coils shall be furnished with a thermal expansion valve sized to accommodate the condensing unit selected to meet the load.
4. Steam coils shall be the freeze resistant double tube, distribution type utilizing a tube-in-tube design with a long life copper header. Non-distributing type coils are not acceptable. Ferrous materials in the header are also not acceptable.
5. All coils shall be pressure tested at no less than 350 psig at the factory to ensure that they are leak tight.
6. Electric heat elements shall be the open wire type. They shall be mounted in individual heavy gage galvanized steel frames and suspended in ceramic insulators.
7. Dual capillary type thermal sensing elements, one automatic reset and one manual reset, shall be employed to protect the unit from overheating in the event of abnormal operation.
8. Each circuit above 48 amps shall be protected by its own fuses rated for the duty and voltage to which they are applied
9. The unit must be constructed such that troubleshooting or adjustment of the controls can be done while the unit is operating normally.

F. Pipe Tunnel:

Rated 500 to 1500 cfm vertical units and rated 750 to 1500 cfm horizontal units shall have an integral pipe tunnel that can be used for piping across the unit. This tunnel shall be insulated, with closed cell insulation, from the unit and accessible from each end compartments to allow maximum flexibility of crossover piping installation.

G. Drain Pans:

1. Unit drain pan shall be double sloped welded galvanized steel to prevent standing water.
2. Drain pan will be coated to prevent external condensation during cooling.
3. Drain connections (7/8 in. OD) shall be supplied on both ends of pan for field conversion of slope and drain hand connection if required.
4. Drain pan slope shall be field convertible without removing the coil module.
5. Heating only units shall come equipped with a double sloped drain pan for future cooling needs.
6. Horizontal units shall have drain pan connection centerline located 5 in. above the bottom to provide easy piping to condensate disposal system.

H. Fans and Motor:

1. Fan and motor assembly shall be direct driven. One end of drive shaft shall be mounted in a sleeve-type or ball bearing, with other end of shaft supported by motor bearings.
2. Fan wheels shall be double-width, double-inlet with forward-curved blades, and shall operate at low speed. Fan wheels shall be mounted on a hollow one piece steel shaft.
3. Fan wheels shall be statically and dynamically balanced.
4. Fan (blower) housings shall be constructed from heavy-gage steel and mounted to a heavy-gage galvanized steel fan deck.
5. To prevent vibration transmission to the unit frame, motor and shaft bearing shall be resiliently mounted. The drive shaft shall be connected to motor with a flexible coupling.
6. Fan motors shall be mounted outside of the airstream on a heavy-gage steel partition and removable without removing the blower module.
7. Units with factory-supplied controls (UV Open controller option) and units without factory-supplied controls that are used in high-static applications shall be supplied with 3-speed, 120, 240 or 277 volt, single-phase, 60 Hz, electronically commutated motors (ECM). Units without controls shall be supplied with permanently split capacitor (PSC) multi-tap transformer motors as standard. Option of ECM motor without unit controls is also available. All motors shall have integral high temperature reset and shall be protected with cartridge-type fuse(s).

I. Filters:

1. Unit shall be supplied with 1-in. throwaway filter. The unit shall be capable of incorporating a 2 in. filter. For even loading, filter shall be positioned to filter mixed outdoor and return air.

Guide specifications (cont)



2. Filter track shall be field adjustable to accept 1-in. or 2-in. permanent or renewable media replacement filters.

J. Dampers:

1. Unit shall contain a single outdoor-air/return-air damper with multiple sealing points. Damper shall be constructed of extruded aluminum with external closed cell insulation. The damper assembly shall include an anti-draft plate to prohibit outdoor air from penetrating the classrooms through the damper assembly.
2. A single face/bypass damper with multiple sealing points constructed of extruded aluminum shall be available.

K. Controls and Safeties:

1. The manufacturer shall furnish, install, wire and factory test a complete control package suitable for the unit type(s) selected. The control package shall be capable of stand-alone operation or networked through Carrier's i-Vu® Open control system or a BACnet building automation system; and shall have all of the necessary sensors and accessories to monitor, control and ensure complete and safe operation of the unit.
2. The minimum position of the outdoor-air/return-air actuator shall be adjustable by the installing contractor and/or the owner/operator.
3. ASHRAE Cycles I, II and III shall be available.
4. Non-fused disconnect switch shall be provided.

NOTE: Factory-installed controls by another option must be quoted on a job-by-job basis. Factory may wire controls and actuator based on request. However, setting the actuator (switch settings, tightening clamp to damper shaft, torque pre-loading, etc.) is the responsibility of the customer.

L. Special Features:

The following optional features are available. See your local Carrier Sales Office for amended specifications.

1. Storage Cabinet:

- a. Open cabinet shall be fabricated from furniture-quality cold rolled steel. Cabinet shall be shipped fully assembled less the top section. Top section shall be field-installed following the installation guide. Bottom and back of cabinet shall be fabricated from 18-gage steel and shall be gusseted for extra support. Side panels shall be fabricated from 18-gage steel and will be fabricated such that it will have additional vertical rigidity. Fully adjustable shelf shall be fabricated from 18-gage steel and may be gusseted (depending on length) for additional support. Cabinet base shall be fabricated from 18-gage steel and will have two horizontal 16-gage angles welded between the base supports to give cabinet additional vertical support. Base shall

have four vertical leveling legs which will allow up to 1 in. of vertical adjustment. Cabinet will be cleaned and phosphatized prior to the application of a powder coat finish. Color to be selected by the architect.

b. Tops are steel or Formica finish as follows:

- 1) Steel tops shall be shipped separately from cabinet. Tops shall be fabricated from 18-gage furniture-quality cold rolled steel. Angle gussets will be welded the full length of top for extra vertical rigidity. Tops shall be sanded to remove all spot weld blemishes prior to the phosphatizing wash process. Tops will then have powder finish applied and baked at 400 F for 10 minutes. Color to be selected by the architect.
- 2) Formica finish tops shall be shipped separately from cabinets. Tops shall be fabricated from 1-in. solid furniture grade particleboard. Tops greater than 5 ft-0 inches in length shall have an angle gusset support extending the full length of the cabinet for additional vertical support. Tops to be fastened to cabinets with four-20 x 1 in. bolts into threaded inserts mounted in the Formica tops. The architect shall choose Formica color and style from the Formica selector.

c. Cabinet backs are as follows:

- 1) False back cabinet shall have an open space behind the back of cabinet for piping and electrical conduits. Cabinet will be properly gusseted to support the top of unit over the false back area.
- 2) Draft stop back — aluminum bar-grille cabinet to have a back extension to draw air from the wall or window behind the unit. Inlet to be pencil-proof aluminum bar-grille. Grille shall be a minimum of 0.070 in. thick with a minimum free area of 62%. Grille to be clear anodized with an R-204 finish. Inlet air to be controlled by a variable slide type damper. Damper to be set at proper adjustment with a security screw.
- 3) Louvered outlet cabinet shall have back extension to enclose finned-tube radiation. Outlet to be pencil-proof, punched louvered grille. A louvered toe plate, powder-coated to match cabinet color, shall be supplied.
- 4) Bar-grille outlet cabinet shall have back extension to enclose finned-tube radiation. Outlet to be pencil-proof aluminum bar-grille. Grille to be a minimum of 0.070 in. thick and shall have an R-204 clear anodized finish. A louvered toe

plate, powder-coated to match cabinet color, shall be supplied.

- d. Sliding door shall be fabricated from 18-gage furniture-quality, cold rolled steel. Doors shall be gusseted where required for extra rigidity. Doors shall be easily removable without tools. Doors sliding mechanism shall be of a durable polyethylene material no less than 0.060 in. thick. Optional key lock available. Doors shall be powder coated to match the cabinet's color.
2. Filler Sections:
 - a. Filler sections (top panels) shall be fabricated from 18-gage furniture-quality cold rolled steel. Filler sections shall be properly gusseted for extra rigidity. Filler section to be powder coated to match cabinet color.
 - b. End panels to be fabricated from 18-gage furniture-quality cold rolled steel. End panels to be powder coated to match the cabinet's color.
 - c. Corner sections shall be fabricated from 18-gage cold rolled steel and shall be properly gusseted for extra rigidity. Corner section shall be powder coated to match cabinet color.
 - d. Wall support angles and adjustable floor angles shall be included for installation.
 - e. Subbase shall be available on vertical units and require field installation. The standard recessed base on a vertical unit shall be 3 in. tall and have a return-air toe space grille, which will require a separate shipped sub-base to be installed under the standard unit.
 3. Draft Stop Enclosures:

Draft stop enclosures (draft elimination) shall be fabricated from 18-gage galvanized steel (optional 16-gage galvanized steel) and powder-coated to match cabinet color.

 - a. Louvered — Inlet shall be pencil-proof, punched louvered grille. Inlet air to be controlled by an 18-gage blade damper. Damper assembly will be fabricated from galvanized steel and powder coated to match the cabinet's finish. Damper operator will be a $\frac{1}{2}$ in. Acme threaded screw for variable adjustment. Damper to be adjusted by a $\frac{3}{16}$ in. Allen wrench.
 - b. Aluminum Bar-Grille — Inlet shall be pencil-proof aluminum bar-grille. Grille to be a minimum of 0.070 in. thick with a minimum free area of 62%. Grille to be clear anodized with an R-204 finish. Inlet air to be controlled by a variable slide type damper. Damper to be set at proper adjustment with a security screw.

4. Pipe Enclosures:

Pipe enclosures shall be fabricated from 18-gage galvanized steel (optional 16-gage galvanized steel and shall be powder-coated to match cabinet color.

5. Vertical units exterior access panel shall be available in 14-gage steel and non-standard paint colors.
6. Sink and Bubbler Units:
 - a. Cabinet shall be fabricated from furniture-quality cold rolled steel. Cabinet shall be shipped fully assembled less the top section. Top section shall be field-installed following the installation guide. Bottom and back of cabinet shall be fabricated from 18-gage steel and shall be gusseted for extra support. Side panels shall be fabricated from 18-gage steel and will be fabricated such that they will have additional vertical rigidity. Cabinet base shall be fabricated from 18-gage steel and will have a horizontal 16-gage angle welded between the base supports to give cabinet additional vertical support. Base shall have four vertical leveling legs which will allow up to 1 in. of vertical adjustment. Cabinet will be cleaned and phosphatized prior to the application of a powder coat finish. Color to be selected by the architect.
 - b. Tops are stainless steel or Formica finish (compatible with storage cabinet top specifications). Bowls are stainless steel Type 304, 18-8 polished and sound-deadened. On double-bowl units, sink bowl is 16 in. x $11\frac{1}{2}$ in. x $7\frac{1}{2}$ in. deep, bubbler bowl is $12\frac{1}{2}$ in. x $9\frac{1}{2}$ x $13\frac{3}{4}$ in. deep. On single-bowl units, sink bowl is 16 in. x $11\frac{1}{2}$ in. x $7\frac{1}{2}$ in. deep and accommodates both faucet and bubbler. Chrome faucet, bubbler, and drain fittings shall be supplied.
 - c. Sliding door shall be fabricated from 18-gage furniture-quality, cold rolled steel. Doors shall be gusseted where required for extra rigidity. Doors shall be easily removable without tools. Doors sliding mechanism shall be of a durable polyethylene material no less than 0.060 in. thick. Key lock included. Doors shall be powder coated to match the cabinet's color.
7. Valve package options shall include all valves required for both 2-way and 3-way cooling and heating applications. Valve package options shall include wye strainers, flow setters, P/T (pressure/temperature) ports, ball valve and unions. The valve package shall include all valves required to match to the ASHRAE control cycles.

Guide specifications (cont)



8. Wall-mounted temperature sensor shall be available for the unit and capable of wall mounting.
9. Wall-mounted air quality CO₂ sensor shall be available.
10. Architectural accessories shall be available to install along side of the vertical units. Two-ft to 5-ft cabinets are available.
11. Trim flanges shall be available for horizontal units.
12. Subbases shall be available for vertical units.
13. Touch-up paint shall be available to match cabinet color.

