

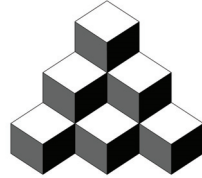

Product Data

OMNIZONE™ 50BRN,BZN006-024 Water-Cooled and Remote Air-Cooled Indoor Self-Contained Systems

5 to 20 Nominal Tons



OMNIZONE™

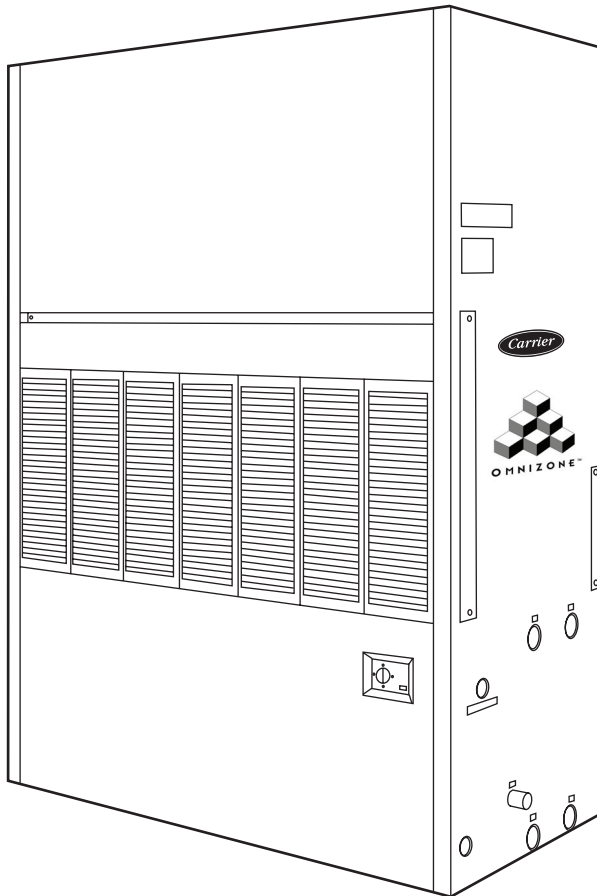

The 50BRN,BZN water-cooled and remote air-cooled indoor, self-contained units offer:

- Water-cooled models available in nominal 5 to 20-ton capacities, remote air-cooled models available in nominal 5 to 15-ton capacities
- Compact, durable, and attractive cabinet fits any working environment
- Ducted or free-blow applications
- High-efficiency cooling for commercial and industrial projects
- Ideal solution for spot cooling applications

Features/Benefits

The OmniZone 50BRN,BZN units are efficient and self-contained for today's cooling needs.

Application versatility

The 50BRN (water-cooled) and 50BZN (condenserless) systems are available in 6 convenient sizes, ranging from 60,000 to 240,000 Btuh (50BRN), to ideally meet the needs for cooling restaurants, retail stores, warehouses, offices, and building additions.

These units can be installed in an equipment room or the conditioned space and specified for either ducted applications or free-blow applications with an accessory plenum.

Features/Benefits (cont)



Easy installation and maintenance

The units are completely prepped and wired at the factory to assure time and money-saving installation and service. Interior access panels are easily removed to provide speedy inspection and service of internal components and controls, and all service work may be done from the front of the unit. Precision engineered parts translate to a quality built, reliable design that will operate efficiently, minimize service calls, and provide years of reliable operation.

Designed for customer satisfaction

Where space and styling are important considerations, 50BRN and 50BZN units are designed to exceed expectations. The stylish grilles and painted finish will fit any environment attractively. These packaged systems provide the user with economy and product satisfaction in cooling, heating (with accessory heating coil added), dehumidification, filtering, and air circulation.

Special features for outstanding performance

- Attractive, high-impact polystyrene air inlet grilles (sizes 006-014 only) enhance unit appearance, while also covering the filter opening.
- High-efficiency scroll compressors deliver quiet, reliable cooling capacity. Compressor motor protection is assured by quick-acting, internal sensing elements that prevent trouble before it starts.
- High-efficiency, brazed-plate condensers provide maximum exposed heat transfer surface for greater heat rejection with less water, and can operate at up to 400 psig working pressure.
- Space-saver slab-type evaporator coils use advanced heat transfer technology and provide peak heat transfer efficiency with large coil face area. Fins are mechanically bonded to nonferrous seamless tubing for efficient leak-free operation.
- Quiet fan performance moves large volumes of indoor air. Compact housing and specially designed discharge air section provide superior air handling capability.

NOTE: All units have the capability to cycle fan with compressor operation for improved operating efficiency.

- Convenient electrical control center contains all factory pre-wired control devices. Extra 24-v power is factory-provided to operate condenser fans (50BZN unit) and keep installation costs low.
- Using a specially designed, sloped condensate pan prevents water accumulation in the basepan, meeting the ASHRAE 62 (American Society of Heating, Refrigeration, and Air Conditioning Engineers) indoor-air quality standards to provide a comfortable and safe occupied space. As a result of this design, the coil is easily accessed from the front of the unit for cleaning.
- The weather-resistant cabinets are constructed of galvanized steel, bonderized, and coated on all external surfaces with a pre-painted baked enamel finish. The paint finish is nonchalking and is capable of withstanding ASTM (American Society for Testing and Materials) Standard No. B117 500-hour salt spray test.
- A choice of controls provides the most flexibility to meet any application. Choose from any of Carrier's full line of programmable or non-programmable, communicating or non-communicating thermostats.
- Full compressor protection is assured by several devices, including Cycle-LOC™ current-sensing lockout relay, Time Guard II time delay control, and high and low-pressurestats. These devices lock out the compressor(s) under abnormal operating conditions to prevent compressor damage and ensure long life.
- The 50BRN,BZN units are fully warrantied as shipped from the factory, including 1 year on all parts and 5 years on the compressor motor.
- Easy-to-operate controls provide a virtually mistake-proof control panel.
- Two-stage capacity control in unit sizes 012-024 provides back-up protection, additional operating efficiency, and energy savings.
- All motors are protected against single-phasing conditions. Units are built in an ISO 9001 (International Standards Organization) certified manufacturing facility, and are fully run-tested. In addition, all units have as standard the capability to indicate a need for service.
- Dual condensate drain locations provide a choice when installing the unit. For drain trapping, the drain location best suited to a particular application can be used, saving both installation time and expense. A built-in secondary drain provides protection against a plugged primary drain, and may eliminate the need to provide an additional drain pan at the jobsite.

Table of contents

	Page
Features/Benefits	1-3
Model Number Nomenclature	3
ARI Capacity Ratings	4
Physical Data	5,6
Field-Installed Accessories	6
Base Unit Dimensions	7-10
Accessory Dimensions	11,12
Selection Procedure	13
Performance Data	14-28
Electrical Data	29,30
Typical Wiring Schematics	31-34
Controls	35
Typical Piping and Wiring	36
Application Data	37-39
Guide Specifications	40-43

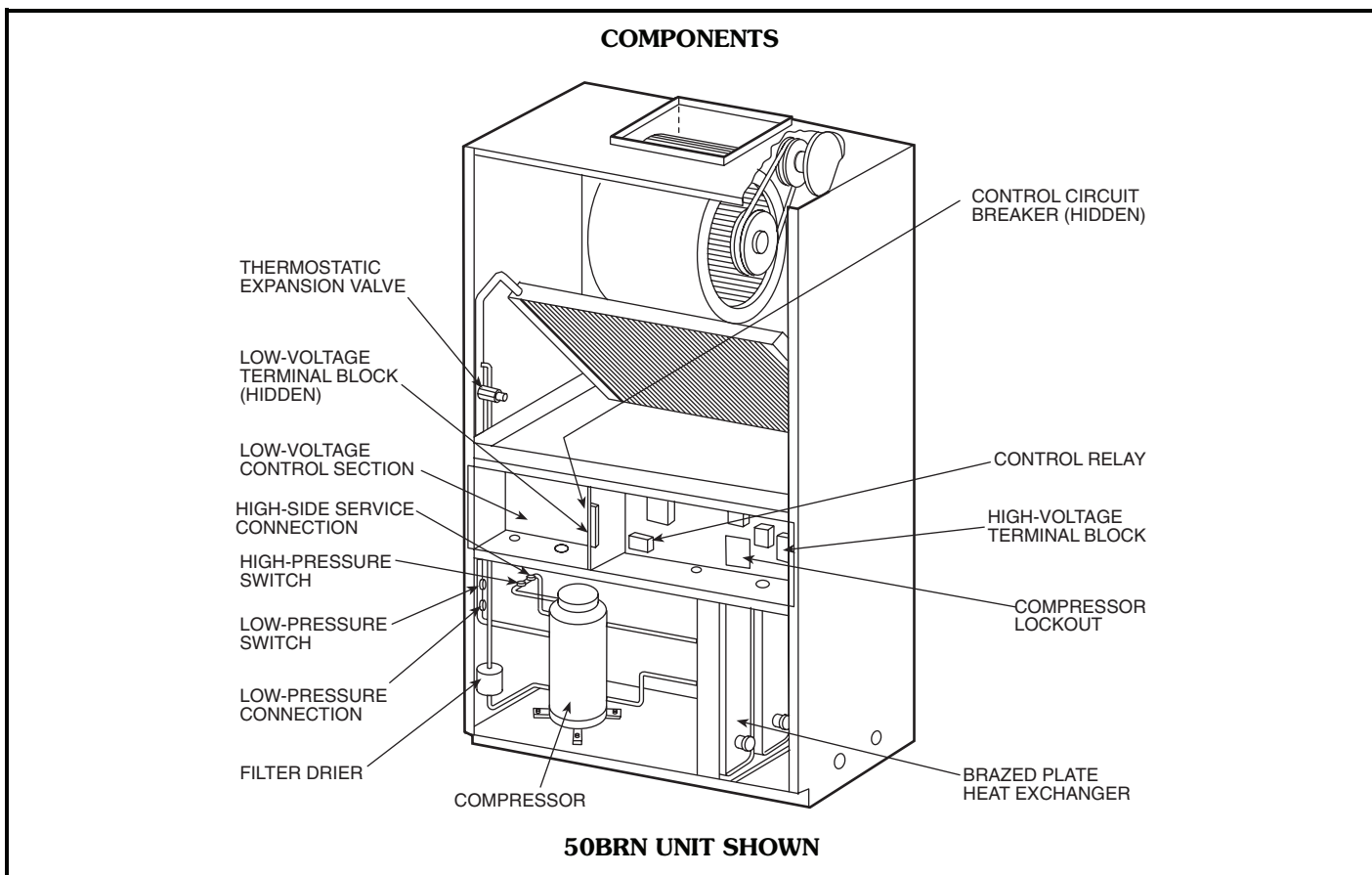

Model number nomenclature

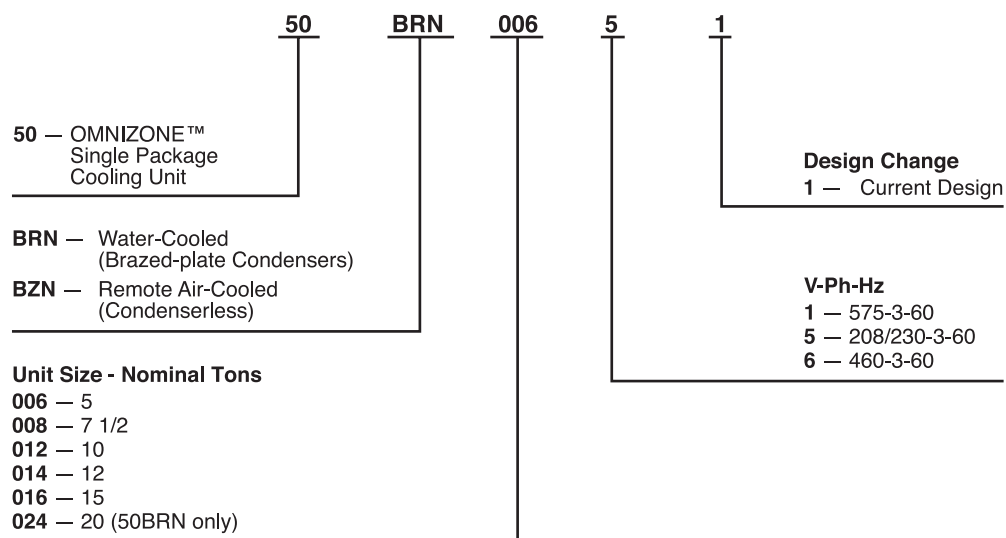

ARI* capacity ratings



UNIT	CAPACITY (Btuh)	EER	ASHRAE 90.1 COMPLIANT
50BRN006	58,000	12.2	Yes
50BRN008	78,000	12.5	Yes
50BRN012	115,000	12.5	Yes
50BRN014	133,000	11.6	Yes
50BRN016	145,000	10.7	No
50BRN024	224,000	12.0	Yes
50BZN006/09BY006	59,000	9.1	No
50BZN008/09BY008	83,700	9.4	No
50BZN012/09BY012	123,000	9.0	No
50BZN014/09BY014	131,000	9.3	No
50BZN016/09DE016	161,000	9.4	No

LEGEND

EER — Energy Efficiency Ratio

*Air Conditioning and Refrigeration Institute.

NOTE: Rated in accordance with ARI Standard 360-2001. Ratings are net values, reflecting the effects of circulating fan heat. Ratings are based on:

Cooling Standard: 80 F dry bulb, 67 F wet bulb indoor entering air temperature and 95 F dry bulb air entering outdoor unit.



Physical data



50BRN

UNIT SIZE 50BRN	006	008	012	014	016	024
NOMINAL CAPACITY (TONS)	5	7½	10	12	15	20
OPERATING WEIGHT (lb)						
Base Unit	560	620	880	950	980	1422
Plenum	40	44	60	66	73	120
COMPRESSOR						
Model	SR58	SR75	SR58	SR58/SR75	SR75	SR75
Quantity	1	1	2	1/1*	2	3
Rpm				3500		
Oil Charge (oz)	44	50	44/44	44/50	50/50	50/50/50
Steps of Control	1	1	2	2	2	2
OPERATING CHARGE†						
No. of Circuits...Charge per ckt	1...5.2**	1...5.5**	2...4.35/4.45**	2...4.95**	2...6.55/7.3**	3...6.0
HOLDING CHARGE**						
Nitrogen	No	No	No	No	No	No
CONDENSER — WATER TYPE						
Quantity	1	1	2	2	2	3
Nominal Gpm	15	22	30	36	45	60
Gpm Range	10-20	15-30	20-40	24-48	30-60	40-80
Max Working Pressure (psig)	450	450	450	450	450	450
Min Entering Water (F)	45	45	45	45	45	45
Max Entering Water (F)	105	105	105	105	105	105
Water Volume (Gal)	0.61	0.61	1.22	1.22	1.22	1.83
INDOOR FAN						
Nominal Cfm	2000	3000	4000	4800	6000	8000
Cfm Range	1500-2500	2250-3750	3000-5000	3750-6000	4500-7400	6,000-10,000
Fan Size (in.)	12 x 12	12 x 12	12 x 15	15 x 15	15 x 15	12 x 12
Number of Fans	1	1	1	1	2	2
Standard Speed Range (Rpm)	1100-1505	1005-1380	955-1205	845-1065	1045-1305	1090-1360
Max Allowable Rpm	1680	1500	1350	1350	1530	1475
Motor Rpm	1750	1750	1750	1750	1750	1750
Belt Quantity...Type	1...A26	1...A27	1...B34	1...B39	2...A36	2...B44
Fan Pulley (in.)	4.3	4.7	7.7	8.7	6.7	7.7
Motor Pulley (in.)	2.7-3.7	2.7-3.7	4.2-5.3	4.2-5.3	4.0-5.0	4.8-6.0
Nominal Hp...Frame Size	1.5...145T	2...145T	3...182T	5...184T	5...184T	7.5...213T
Fan Shaft Size (mm)	20	20	20	20	25	25
Motor Shaft Size (in.)	7/8	7/8	1 1/8	1 1/8	1 1/8	1 3/8
Center Distance (in.)	18	18	18	16	14	14
INDOOR COIL						
Number of Rows...Fin/in.	3...15	4...14	4...15	4...15	4...15	4...15
Face Area (sq ft)	5.2	7.0	9.5	10.9	13.5	18.3
RETURN AIR FILTERS						
Quantity...Size (in.)	2...20 x 25	3...16 x 25	2...20 x 25 1...16 x 25	4...16 x 25	2...25 x 25 1...20 x 25	10...16 x 16
CONTROLS						
High Pressure Cutout (psig) ± 10				24 V Provided in Unit		
Cut-in (psig) ± 20				395		
Low Pressure Cutout (psig) ± 4				298		
Cut-in (psig) ± 7				27		
Fusible Plug				67		
Time Guard II Device				203 F		
Time Guard II Device				5 Minutes on Each Circuit		
CONNECTIONS						
Water Connections						
Inlet (in.) — Qty...Type	1...1¼ MPT	1...1¼ MPT	2...1¼ MPT	2...1¼ MPT	2...1¼ MPT	3...1¼ MPT
Outlet (in.) — Qty...Type	1...1¼ MPT	1...1¼ MPT	2...1¼ MPT	2...1¼ MPT	2...1¼ MPT	3...1¼ MPT
Condensate Drain Line — Qty...Type						

*Circuit 1/Circuit 2.

†Based on 25 ft of interconnecting tubing (standard liquid-line size, 50BRN only).

**Factory charged.

NOTE: Fan shaft bore size is in metric units. Contact your local representative for correct replacement parts.

Physical data (cont)



50BZN

UNIT SIZE 50BZN	006	008	012	014	016
NOMINAL CAPACITY (TONS)	5	7½	10	12	15
OPERATING WEIGHT (lb)					
Base Unit	530	580	820	870	910
Plenum	40	44	60	66	73
COMPRESSOR			Carrier Scroll		
Model	SR58	SR75	SR58	SR58/SR75	SR75
Quantity	1	1	2	1/1*	2
Rpm			3500		
Oil Charge (oz)	44	50	44/44	44/50	50/50
Steps of Control	1	1	2	2	2
OPERATING CHARGE†					
No. of Circuits...Charge per ckt	1...5.2**	1...5.5**	2...4.35/4.45**	2...4.95**	2...6.55/7.3**
HOLDING CHARGE**					
Nitrogen	Yes	Yes	Yes	Yes	Yes
INDOOR FAN	Adjustable, Belt-Driven, Centrifugal				
Nominal Cfm	2000	3000	4000	4800	6000
Cfm Range	1500-2500	2250-3750	3000-5000	3750-6000	4500-7400
Fan Size (in.)	12 x 12	12 x 12	12 x 15	15 x 15	15 x 15
Number of Fans	1	1	1	1	2
Standard Speed Range (Rpm)	1100-1505	1005-1380	955-1205	845-1065	1045-1305
Max Allowable Rpm	1680	1500	1350	1350	1530
Motor Rpm	1750	1750	1750	1750	1750
Belt Quantity...Type	1...A26	1...A27	1...B34	1...B39	2...A36
Fan Pulley (in.)	4.3	4.7	7.7	8.7	6.7
Motor Pulley (in.)	2.7-3.7	2.7-3.7	4.2-5.3	4.2-5.3	4.0-5.0
Nominal Hp...Frame Size	1.5...145T	2...145T	3...182T	5...184T	5...184T
Fan Shaft Size (mm)	20	20	20	20	25
Motor Shaft Size (in.)	7/8	7/8	1 1/8	1 1/8	1 1/8
Center Distance (in.)	18	18	18	16	14
INDOOR COIL	3/8 in. OD, Enhanced Copper Tube, Aluminum Fins				
Number of Rows...Fin/in.	3...15	4...14	4...15	4...15	4...15
Face Area (sq ft)	5.2	7.0	9.5	10.9	13.5
RETURN AIR FILTERS	1 in. Disposable Type				
Quantity...Size (in.)	2...20 x 25	3...16 x 25	2...20 x 25 1...16 x 25	4...16 x 25	2...25 x 25 1...20 x 25
CONTROLS	24 V Provided in Unit				
High Pressure Cutout (psig) ± 10	395				
Cut-in (psig) ± 20	298				
Low Pressure Cutout (psig) ± 4	27				
Cut-in (psig) ± 7	67				
Fusible Plug	203 F				
Time Guard II Device	5 Minutes on Each Circuit				
CONNECTIONS	Sweat Connection				
Refrigerant Connection Type	Sweat Connection				
Hot Gas Connection (in.) Qty...Size	1...5/8 OD	1...5/8 OD	2...5/8 OD	2...5/8 OD	2...5/8 OD
Liquid Connection (in.) Qty...Size	1...5/8 OD	1...5/8 OD	2...5/8 OD	2...5/8 OD	2...5/8 OD
Condensate Drain Line — Qty...Type	1...3/4-in. Standard PVC Stub				

*Circuit 1/Circuit 2.

†Based on 25 ft of interconnecting tubing (standard liquid-line size, 50BZN only).

**Factory charged.

NOTE: Fan shaft bore size is in metric units. Contact your local representative for correct replacement parts.

Field-installed accessories

Supply-air discharge plenum — The plenum is adjustable horizontal and vertical louvers for controlled free-blow into the conditioned space. The plenum mounts easily on top of base unit and matches unit styling.

Heating coils — Coils are for hot water (2-row coil) or steam (one-row coil) with convenient field piping connections on side of unit. Rear return not possible with hot water coils. Coils mount internally to unit.

Evaporator defrost thermostat — For winter start control on 50BZN units, this package provides coil freeze-up protection under low ambient temperature start-up conditions.

Thermostats — A complete line of thermostats is available to meet any control requirements, including Carrier

TEMP System thermostats for diagnostics and communicating capability.

Liquid line solenoid — Use a liquid line solenoid on 50BZN units when long refrigerant lines are used. The solenoid has an electrically operated shutoff valve to be installed at the unit, and stops and starts refrigerant flow in response to compressor operation. The valve maintains a column of refrigerant in the liquid line between compressor operation cycles.

Rear return filter box — Available for unit sizes 006 to 014, the rear return filter box provides side access filter rack when air is through rear return connection. (See bulletin 111-04-54.)

Base unit dimensions



50BRN006-014 UNIT DIMENSIONS

DIM	MM	006 FT. IN.	MM	008 FT. IN.	MM	012 FT. IN.	MM	014 FT. IN.
A	1970	6'-5 9/16"	1970	6'-5 9/16"	1984	6'-6 7/64"	1984	6'-6 7/64"
B	1040	3'-4 15/16"	1231	4'-0 15/32"	1422	4'-7 31/32"	1613	5'-3 1/2"
C	580	1'-10 27/32"	580	1'-10 27/32"	700	2'-3 9/16"	700	2'-3 9/16"
D	295	0'-11 5/8"	295	0'-11 5/8"	335	1'-1 3/16"	335	1'-1 3/16"
E	584	1'-11"	584	1'-11"	704	2'-3 11/16"	704	2'-3 11/16"
F	225	0'-8 7/8"	225	0'-8 7/8"	121	0'-4 3/4"	121	0'-4 3/4"
G	585	1'-11"	585	1'-11"	585	1'-11"	585	1'-11"
H	306	1'-0"	348	1'-1 45/64"	376	1'-2 13/16"	424	1'-4 45/64"
J	254	0'-10"	375	1'-2 3/4"	523	1'-8 5/8"	595	1'-11 7/16"
K	60	0'-2 3/8"	29	0'-1 1/8"	33	0'-1 5/16"	33	0'-1 5/16"
L	317	1'- 1/2"	357	1'-2"	402	1'-3 13/16"	452	1'-5 13/16"
M	60	0'-2 3/8"	60	0'-2 3/8"	150	0'-5 29/32"	150	0'-5 29/32"
N	124	0'-4 7/8"	124	0'-4 7/8"	124	0'-4 7/8"	124	0'-4 7/8"
P	290	0'-11 13/32"	290	0'-11 13/32"	249	0'-9 13/16"	249	0'-9 13/16"
Q	467	1'-6 3/8"	467	1'-6 3/8"	467	1'-6 3/8"	467	1'-6 3/8"
R	81	0'-3 3/16"	81	0'-3 3/16"	81	0'-3 3/16"	81	0'-3 3/16"
S	-	-	-	-	180	0'-7"	180	0'-7"
T	200	0'-7 7/8"	200	0'-7 7/8"	171	0'-6 3/4"	171	0'-6 3/4"
U	25	0'-1"	25	0'-1"	25	0'-1"	25	0'-1"
X	193	0'-7 19/32"	193	0'-7 19/32"	196	0'-7 23/32"	196	0'-7 23/32"
Z	655	2'-1 3/4"	655	2'-1 3/4"	655	2'-1 3/4"	655	2'-1 3/4"
A1	41	0'-1 5/8"	41	0'-1 5/8"	41	0'-1 5/8"	41	0'-1 5/8"
B1	53	0'-2 1/16"	53	0'-2 1/16"	53	0'-2 1/16"	53	0'-2 1/16"
C1	638	2'-1 1/8"	638	2'-1 1/8"	638	2'-1 1/8"	638	2'-1 1/8"
E1	15	0'- 5/8"	15	0'- 5/8"	15	0'- 5/8"	15	0'- 5/8"
F1	260	0'-10 1/4"	260	0'-10 1/4"	260	0'-10 1/4"	260	0'-10 1/4"
G1	640	2'-1 3/16"	640	2'-1 3/16"	642	2'-1 1/4"	642	2'-1 1/4"
H1	260	0'-10 1/4"	260	0'-10 1/4"	260	0'-10 1/4"	260	0'-10 1/4"
J1	640	2'-1 3/16"	640	2'-1 3/16"	642	2'-1 1/4"	642	2'-1 1/4"
K1	914	3"	1105	3'-7 1/2"	1296	4'-3 1/16"	1487	4'-10 9/16"
L1	537	1'-9 1/8"	537	1'-9 1/8"	537	1'-9 1/8"	537	1'-9 1/8"
M1	511	1'-8 1/8"	511	1'-8 1/8"	493	1'-7 3/8"	493	1'-7 3/8"
N1	60	0'-2 3/8"	60	0'-2 3/8"	60	0'-2 3/8"	60	0'-2 3/8"

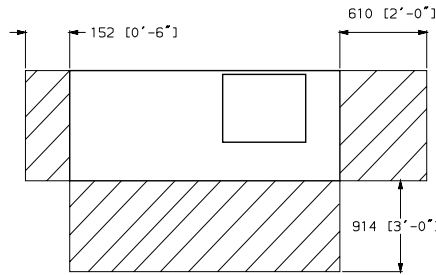

OPERATION CLEARANCE

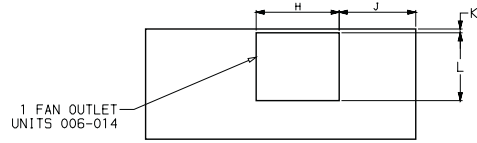

TOP VIEW
(WITH PLENUM REMOVED)

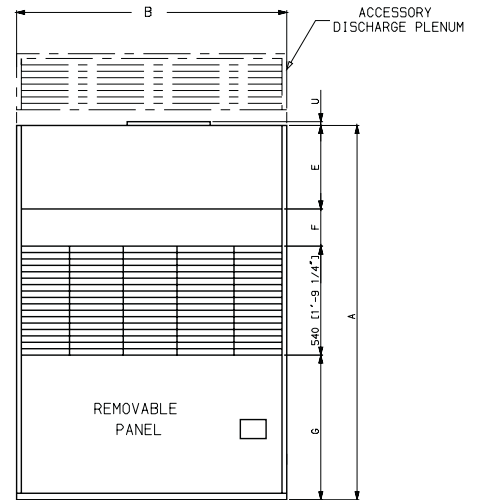
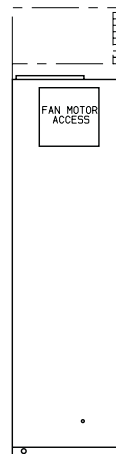

FRONT VIEW

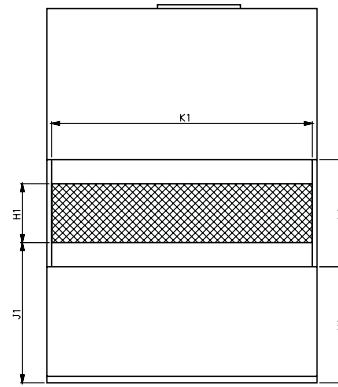
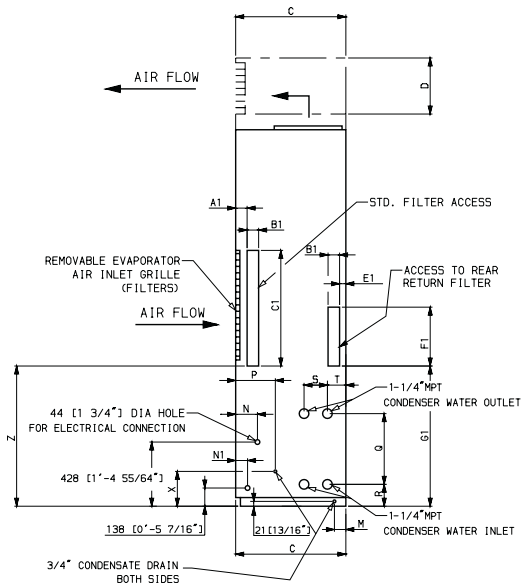

BACK VIEW

L1-REAR RETURN OPTION*
H1-FRESH AIR INTAKE

*Not available with hot water coil.

Base unit dimensions (cont)



50BRN016,024 UNIT DIMENSIONS

DIM	016		024		M	016		024		B1	016		024	
	MM	FT. IN.	MM	FT. IN.		MM	FT. IN.	MM	FT. IN.		MM	FT. IN.	MM	FT. IN.
A	1992	6'-6 7/16"	2260	7'-4 31/32"		150	0'-5 29/32"	180	0'-7 3/32"		1921	6'-3 5/8"	2124	6'-11 5/8"
B	1905	6'-3"	2108	6'-11"	N	21	0'-27/32"	59	0'-2 5/16"	C1	666	2'-4 7/32"	786	2'-6 15/16"
C	650	2'-1 19/32"	770	2'-6 5/16"	P	291	0'-11 15/32"	330	1'-1"	E1	214	0'-8 7/16"	241	0'-9 1/2"
D	406	1'-4"	-	-	Q	118	0'-4 21/32"	157	0'-6 3/16"	F1	238	0'-9 3/8"	456	1'-5 31/32"
E	280	0'-11 1/32"	315	1'-13/32"	R	71	0'-2 13/16"	110	0'-4 11/32"	G1	602	1'-11 23/32"	780	2'-6 23/32"
F	640	2'-1 3/16"	828	2'-8 19/32"	S	20	0'-25/32"	35	0'-1 3/8"	H1	1730	5'-8 1/8"	1974	6'-5 23/32"
G	632	2'-7/8"	632	2'-7/8"	T	20	0'-25/32"	15	0'-19/32"	J1	20	0'-25/32"	20	0'-25/32"
H	348	1'-1 11/16"	372	1'-2 21/32"	U	1778	5'-10"	2022	6'-7 5/8"					
J	408	1'-4 1/16"	479	1'-6 55/64"	X	18	0'-23/32"	16	0'-5/8"					
K	95	0'-3 3/4"	142	0'-5 19/32"	Z	188	0'-7 13/32"	127	0'-5"					
L	357	1'-2 1/16"	403	1'-3 7/8"	A1	2000	6'-6 3/4"	2268	7'-5 9/32"					

1. DIMENSIONS IN [] ARE IN MILLIMETERS.
2. DIRECTION OF AIR FLOW.
3. SERVICE CLEARANCE 0" BACK AND LEFT SIDE, 30" FRONT AND CONTROL BOX ACCESS.
4. UNIT MAY BE USED FOR REAR RETURN, COMPRESSORS AND CONDENSERS ARE ACCESSED THROUGH REAR PANEL.

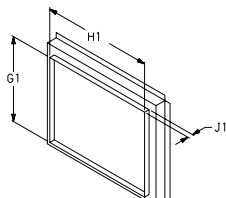

INLET DUCT OPENING DETAIL

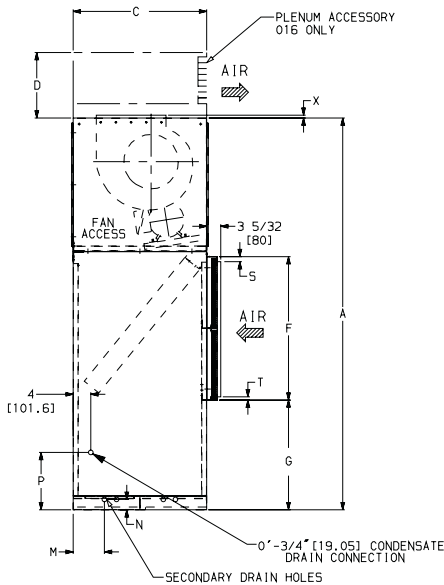

LEFT SIDE

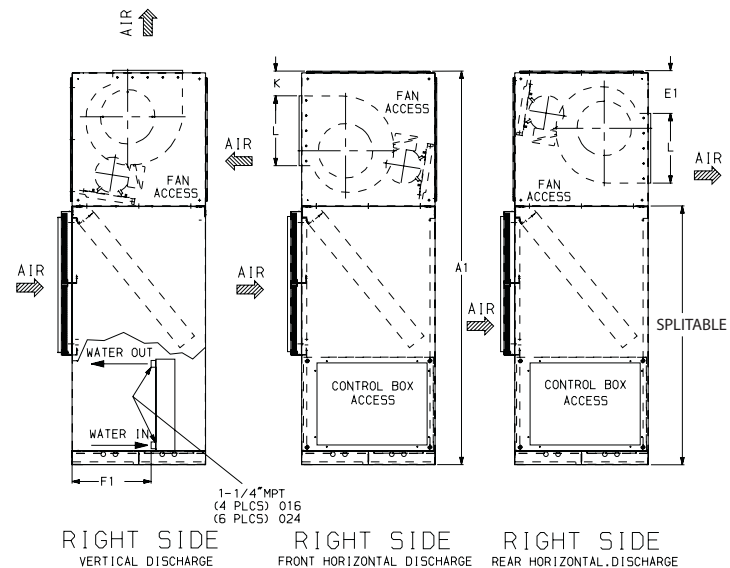

RIGHT SIDE
VERTICAL DISCHARGE

RIGHT SIDE
FRONT HORIZONTAL DISCHARGE

RIGHT SIDE
REAR HORIZONTAL DISCHARGE

SPLITTABLE

NOTES:

1. Unit sizes 016 and 024 do not include return grilles.
2. Only size 024 units are splittable. Fan section can be rotated in the field per diagram.

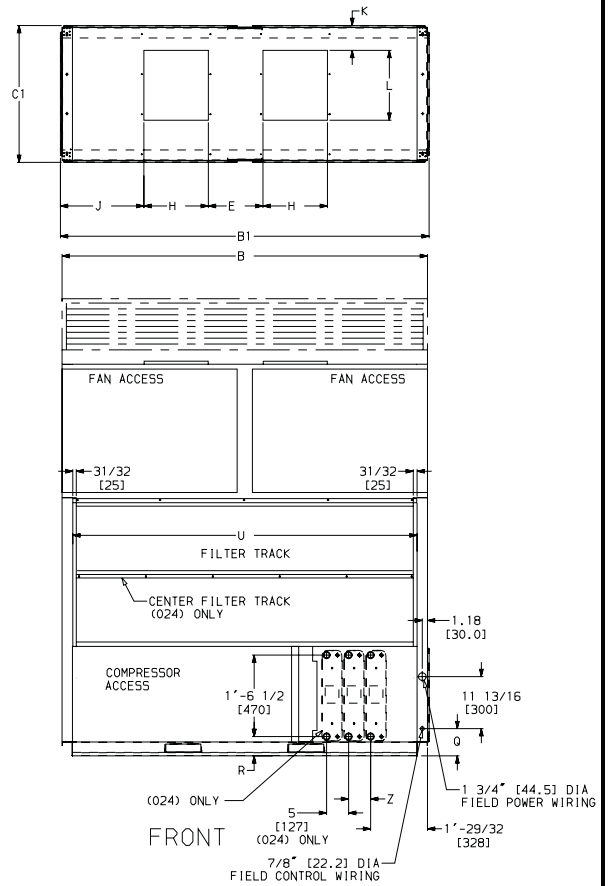

FRONT

50BZN006-014 UNIT DIMENSIONS

DIM	006		008		012		014	
	MM	FT. IN.	MM	FT. IN.	MM	FT. IN.	MM	FT. IN.
A	1970	6'-5 9/16"	1970	6'-5 9/16"	1984	6'-6 7/64"	1984	6'-6 7/64"
B	1040	3'-4 15/16"	1231	4'-0 15/32"	1422	4'-7 31/32"	1613	5'-3 1/2"
C	580	1'-10 27/32"	580	1'-10 27/32"	700	2'-3 9/16"	700	2'-3 9/16"
D	295	0'-11 5/8"	295	0'-11 5/8"	335	1'-1 3/16"	335	1'-1 3/16"
E	584	1'-11"	584	1'-11"	704	2'-3 11/16"	704	2'-3 11/16"
F	225	0'-8 7/8"	225	0'-8 7/8"	121	0'-4 3/4"	121	0'-4 3/4"
G	585	1'-11"	585	1'-11"	585	1'-11"	585	1'-11"
H	306	1'-0"	348	1'-1 45/64"	376	1'-2 13/16"	424	1'-4 45/64"
J	254	0'-10"	375	1'-2 3/4"	523	1'-8 5/8"	595	1'-11 7/16"
K	60	0'-2 3/8"	29	0'-1 1/8"	33	0'-1 5/16"	33	0'-1 5/16"
L	317	1'-1 1/2"	357	1'-2"	402	1'-3 13/16"	452	1'-5 13/16"
M	60	0'-2 3/8"	60	0'-2 3/8"	150	0'-5 29/32"	150	0'-5 29/32"
N	124	0'-4 7/8"	124	0'-4 7/8"	124	0'-4 7/8"	124	0'-4 7/8"
P	290	0'-11 13/32"	290	0'-11 13/32"	249	0'-9 13/16"	249	0'-9 13/16"
Q	107	0'-4 1/4"	107	0'-4 1/4"	150	0'-0 15/16"	150	0'-0 15/16"
R	84	0'-3 5/16"	84	0'-3 5/16"	84	0'-3 5/16"	84	0'-3 5/16"
S	-	-	-	-	180	0'-7 1/16"	180	0'-7 1/16"
T	40	0'-1 9/16"	40	0'-1 9/16"	108	0'-4 1/4"	108	0'-4 1/4"
U	25	0'-1"	25	0'-1"	25	0'-1"	25	0'-1"
X	193	0'-7 19/32"	193	0'-7 19/32"	196	0'-7 23/32"	196	0'-7 23/32"
Z	655	2'-1 3/4"	655	2'-1 3/4"	655	2'-1 3/4"	655	2'-1 3/4"
A1	41	0'-1 5/8"	41	0'-1 5/8"	41	0'-1 5/8"	41	0'-1 5/8"
B1	53	0'-2 1/16"	53	0'-2 1/16"	53	0'-2 1/16"	53	0'-2 1/16"
C1	638	2'-1 1/8"	638	2'-1 1/8"	638	2'-1 1/8"	638	2'-1 1/8"
E1	15	0'- 5/8"	15	0'- 5/8"	15	0'- 5/8"	15	0'- 5/8"
F1	260	0'-10 1/4"	260	0'-10 1/4"	260	0'-10 1/4"	260	0'-10 1/4"
G1	640	2'-1 3/16"	640	2'-1 3/16"	642	2'-1 1/4"	642	2'-1 1/4"
H1	260	0'-10 1/4"	260	0'-10 1/4"	260	0'-10 1/4"	260	0'-10 1/4"
J1	640	2'-1 3/16"	640	2'-1 3/16"	642	2'-1 1/4"	642	2'-1 1/4"
K1	914	3'	1105	3'-7 1/2"	1296	4'-3 1/16"	1487	4'-10 9/16"
L1	537	1'-9 1/8"	537	1'-9 1/8"	537	1'-9 1/8"	537	1'-9 1/8"
M1	511	1'-8 1/8"	511	1'-8 1/8"	493	1'-7 3/8"	493	1'-7 3/8"
N1	60	0'-2 3/8"	60	0'-2 3/8"	60	0'-2 3/8"	60	0'-2 3/8"

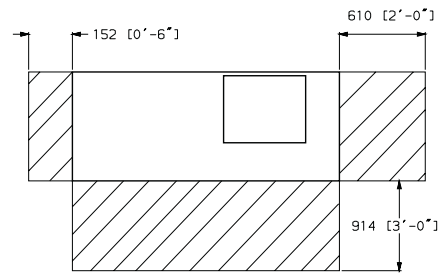

OPERATION CLEARANCE

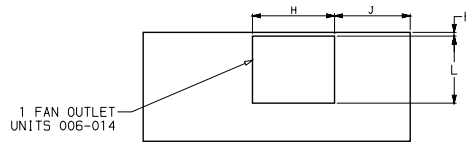

TOP VIEW
(WITH PLENUM REMOVED)

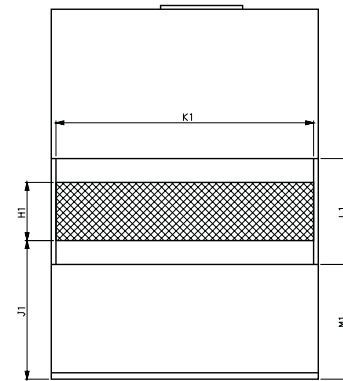
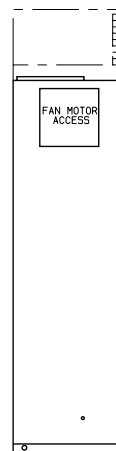

BACK VIEW
L1-REAR RETURN OPTION
H1-FRESH AIR INTAKE

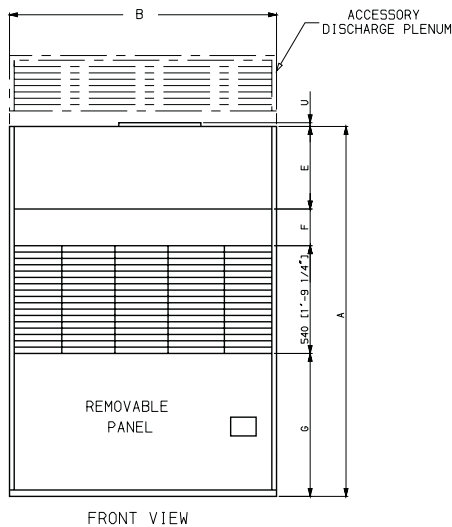

FRONT VIEW

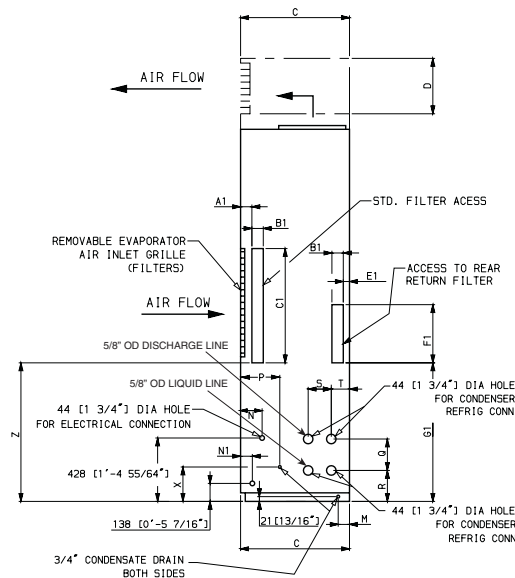

Base unit dimensions (cont)



50BRN016 UNIT DIMENSIONS

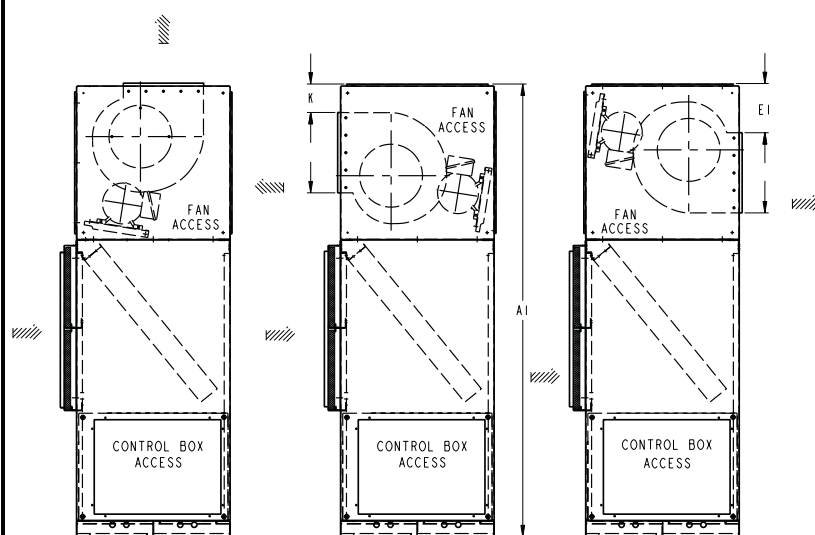
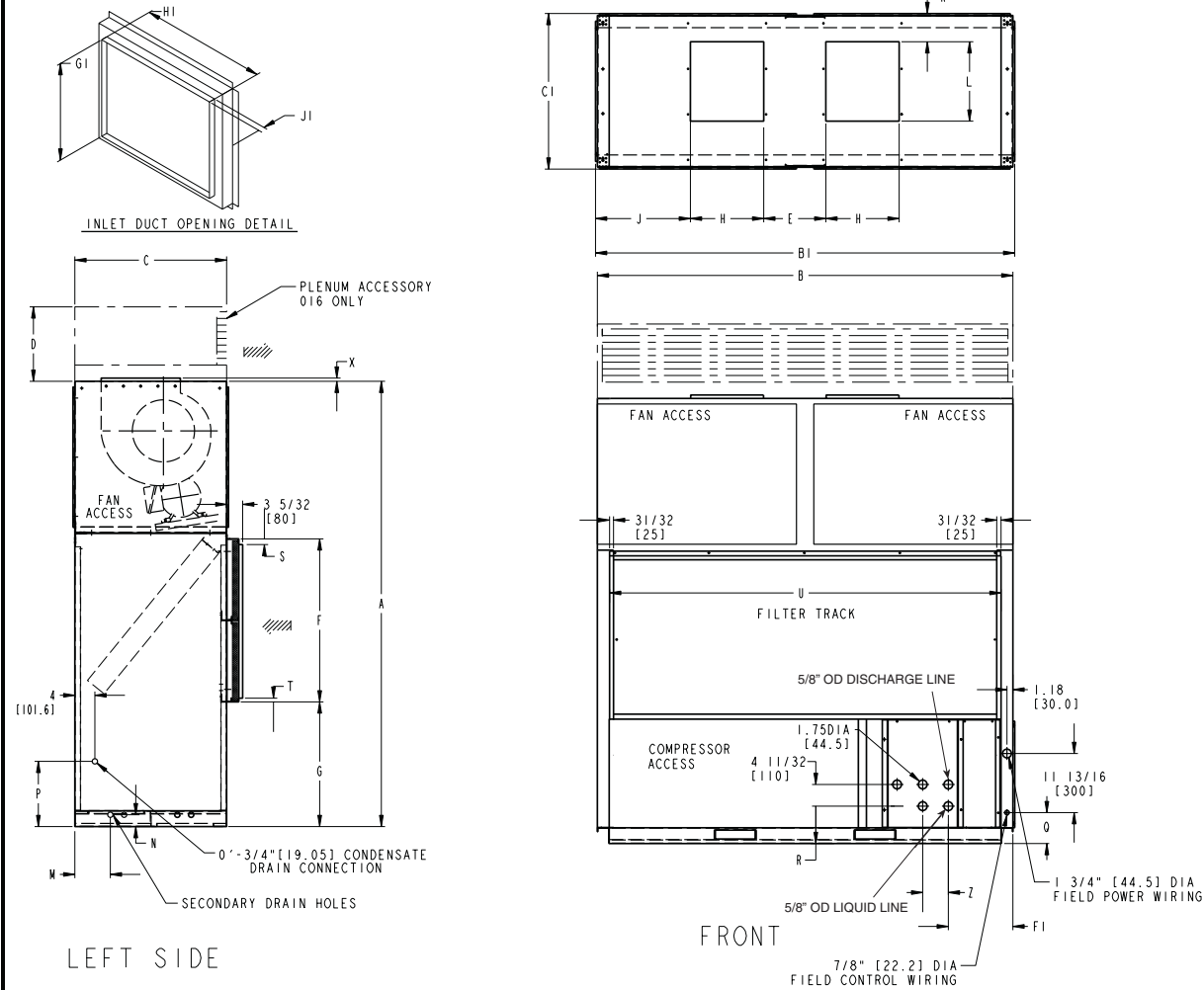

DIM	50BZN016	
	mm	ft-in.
A	1992	6- 6 ⁷ / ₁₆
B	1905	6- 3
C	650	2- 1 ¹⁹ / ₃₂
D	406	1- 4
E	280	0-11 ¹ / ₃₂
F	640	2- 1 ³ / ₁₆
G	632	2- 7 ⁷ / ₈
H	348	1- 11 ¹ / ₁₆
J	408	1- 4 ¹ / ₁₆
K	95	0- 3 ³ / ₄
L	357	1- 2 ¹ / ₁₆
M	150	0- 5 ²⁹ / ₃₂
N	21	0- 2 ⁷ / ₃₂
P	291	0-11 ¹⁵ / ₃₂
Q	118	0- 4 ²¹ / ₃₂

DIM	50BZN016	
	mm	ft-in.
R	151	0- 5 ¹⁵ / ₁₆
S	20	0- 2 ⁵ / ₃₂
T	20	0- 2 ⁵ / ₃₂
U	1778	5-10
X	18	0- 2 ³ / ₃₂
Z	130	0- 5 ¹ / ₈
A1	2000	6- 6 ³ / ₄
B1	1921	6- 3 ⁵ / ₈
C1	666	2- 4 ⁷ / ₃₂
E1	214	0- 8 ⁷ / ₁₆
F1	359	1- 2 ¹ / ₈
G1	602	1-11 ²³ / ₃₂
H1	1730	5- 8 ¹ / ₈
J1	20	0- 2 ⁵ / ₃₂

- NOTES:**
1. Dimensions in [] are in millimeters.
 2. Direction of airflow.
 3. Service clearance 0 in. back and left side, 30 in. front and control box access.
 4. Unit may be used for rear return, compressors and condensers are accessed through rear panel.
 5. Unit size 016 does not include return grille.

Accessory dimensions



HOT WATER COIL

50BRN,BZN006,008

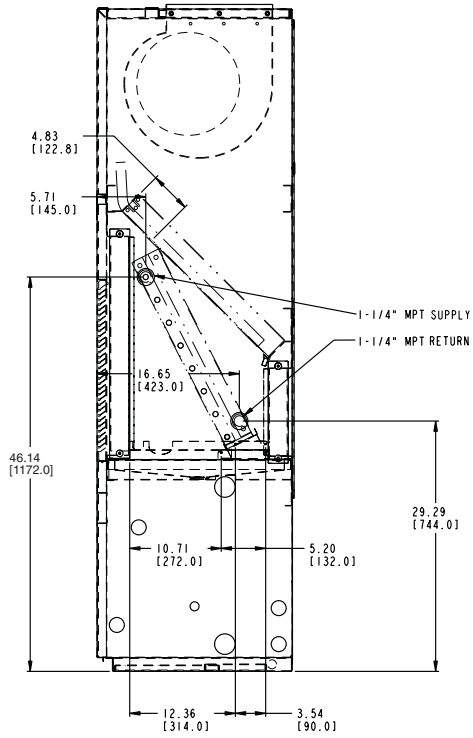

50BRN,BZN012,014

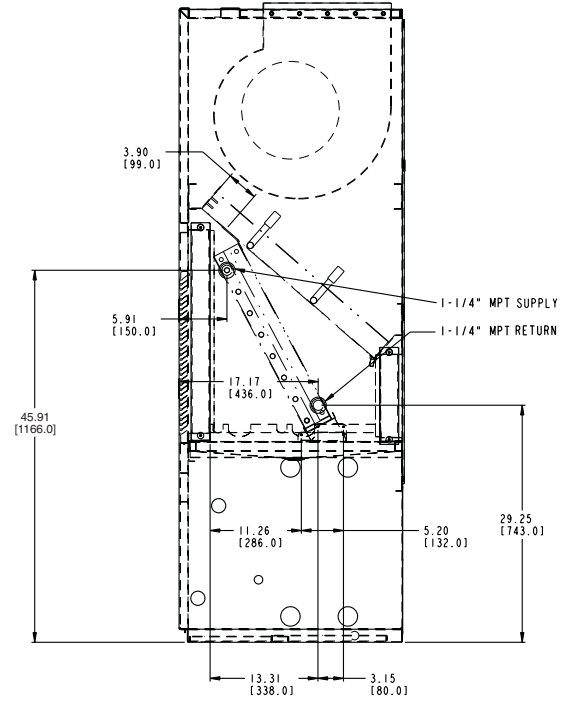

50BRN,BZN016

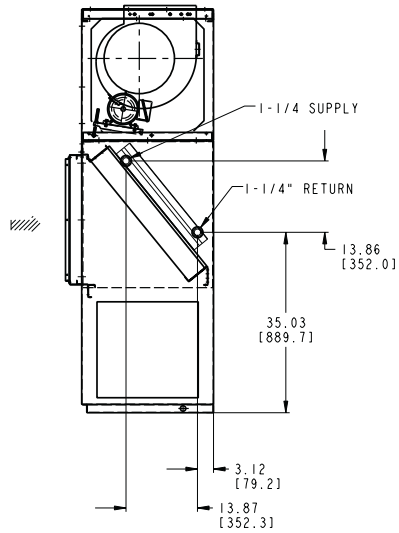

RIGHT SIDE

50BRN024

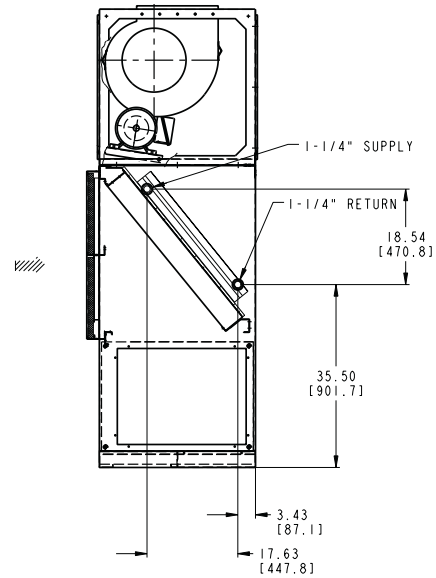

RIGHT SIDE

NOTE: Dimensions in [] are in millimeters.

Accessory dimensions (cont)



STEAM COIL

50BRN,BZN006,008

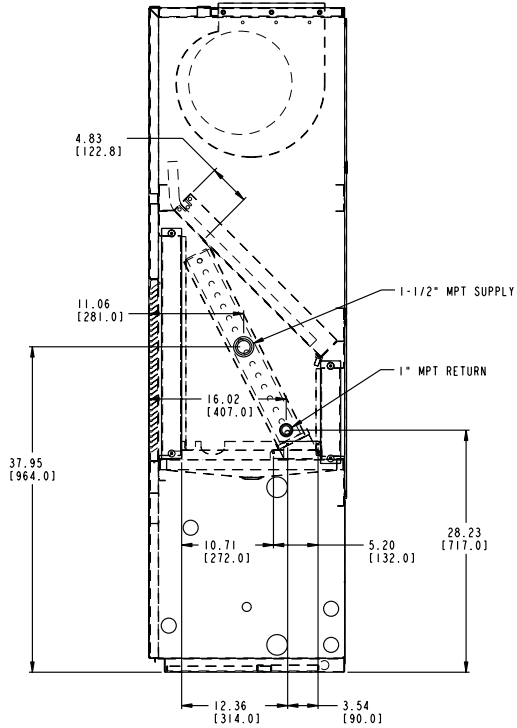

50BRN,BZN012,014

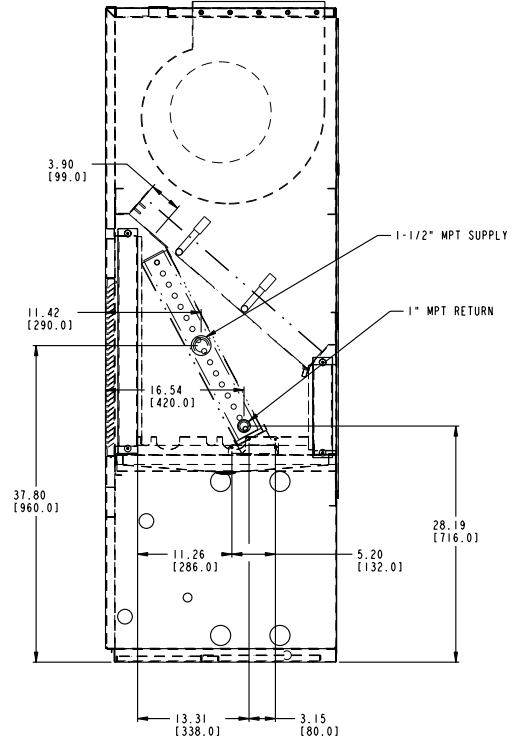

50BRN,BZN016

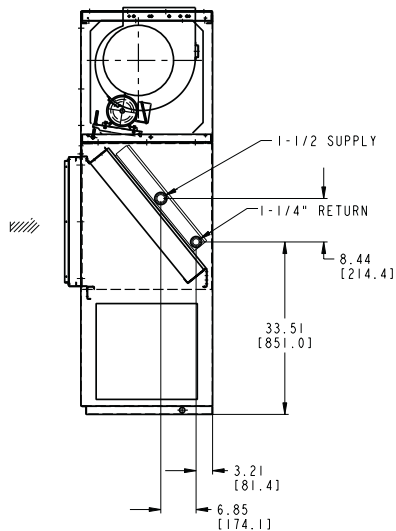

RIGHT SIDE

50BRN024

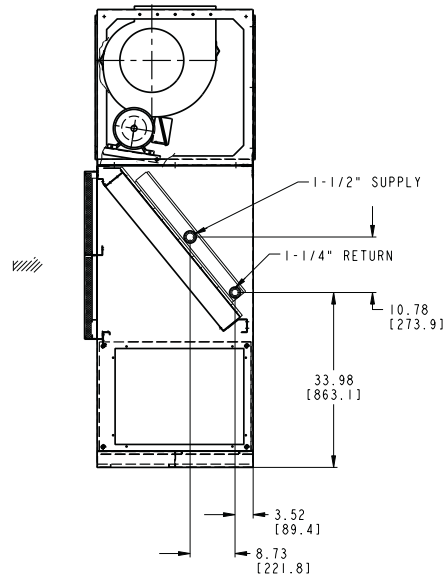

RIGHT SIDE

NOTE: Dimensions in [] are in millimeters.

Selection procedure (with example)



I Determine design conditions.

Given (50BRN012 Water-Cooled/50BZN012 Air-Cooled):

Cooling Requirements

Total Cooling Capacity (TC).....	20,000/111,000 Btuh
Sensible Cooling Capacity.....	84,000/84,000 Btuh
Evaporator Air Quantity.....	4,000/4,000 cfm
Summer Entering-Air Conditions:	
Entering dry bulb (edb).....	82/82 F
Entering wet bulb (ewb).....	67/67 F
Entering Condenser Water Temperature (Water-Cooled Selection)	
Entering Water Temperature (ewt)	85 F/—
Entering Condenser Air Temperature (Air-Cooled Selection) (EAT)	—/95 F
Flow Rate	20 gpm/—
Unit Voltage	460/460-v

Heating Requirements

Total Heating Load (TC) ...	236,000/236,000 Btuh
Winter Entering-Air Temperature (edb).....	60/60 F
Entering Hot Water Temperature (ewt)	200/200 F
or	
Steam Pressure Available	5/5 psig

Fan Requirements

External Static Pressure Required (ESP).....	0.6 /0.6 in. wg
--	-----------------

II Select unit(s) based on cooling requirements.

A. Water-Cooled Selection Method — 50BRN

Enter the Gross Cooling Capacity table on page 16 for unit at 4000 cfm and required wet bulb of 67 F, and read down to the section displaying capacities with 85 F ewt. Find capacity closest to design requirements and read over to find required gpm. For example (50BRN012 unit):

Airflow.....	4000 cfm
Entering Air Temperature	82 F/67 F
TC.....	120,200 Btuh
Corrected SHC (See Correction Factor table below Gross Cooling Capacity table.).....	96,796 Btuh

Compressor Motor Power Input	8.85 kW
Condenser:	
Pressure Drop.....	5.7 ft wg/2.4 psig
ewt	85 F
gpm.....	20.0

B. Air-Cooled Selection Method — 50BZN

Enter the cooling capacity table on page 22 for units at 4000 cfm, and read down to the section displaying capacities at 95 F EAT.

For example (50BZN012 unit with 09BY012 remote air-cooled condenser):

Airflow.....	4000 cfm
Entering Air Temperature	82 F/67 F
Ambient Temperature.....	95 F
TC.....	123,000 Btuh
Corrected SHC (See Correction Factor table below Gross Cooling Capacity table.).....	102,296 Btuh
Compressor Motor Power Input	12.4 kW

III Determine heating capacity.

Enter Accessory Heating Coil Ratings tables, page 26, with selected unit size and air cfm. Read data and correct as indicated.

For example (200 F hot water selection):

Airflow.....	4000 cfm
Entering Air Temperature	60 F
TC.....	247,000 Btuh

IV Fan requirements

External static pressure (ESP) required (without plenum)	0.60 (in. wg)
Static pressure loss through heating coil	0.14 (in. wg)
Total external static required	0.74 (in. wg)

Enter Evaporator Fan Performance curve, page 27 for selected unit size, cfm, and static pressure required to obtain the following data:

For 50BRN/BZN012 at 4000 cfm and 0.74 ESP, by interpolation the fan operates at 988 rpm and requires 1.52 brake horsepower.

Since unit 50BRN/BZN012 standard motor horsepower is 3.0, it will produce the necessary cfm and ESP for this job.

If plenum is to be used, use ESP drop for plenum rather than the ESP described above.

Performance data



GROSS COOLING CAPACITIES 50BRN006 UNIT

EWT (F)	GPM	PRESSURE DROP		AIR ENTERING EVAPORATOR — CFM/BF												
				1500 / 0.13				2000 / 0.16				2500 / 0.19				
		Ft	Psig	Air Entering Evaporator — Ewb (F)												
				72	67	62	57	72	67	62	57	72	67	62	57	
65	10	5.7	2.4	TC	68.0	62.3	56.9	53.5	70.8	65.0	59.8	58.3	72.4	66.5	61.9	61.6
				SHC	32.9	40.9	48.7	53.5	36.1	46.4	55.9	58.3	38.9	51.3	61.3	61.6
				kW	3.55	3.49	3.43	3.39	3.59	3.53	3.47	3.45	3.62	3.55	3.50	3.50
	12.5	9.1	3.8	TC	68.2	62.5	57.1	53.6	71.1	65.2	59.9	58.4	72.6	66.7	62.1	61.7
				SHC	32.9	41.0	48.8	53.6	36.2	46.5	56.0	58.4	39.0	51.4	61.5	61.7
				kW	3.46	3.40	3.35	3.32	3.50	3.44	3.38	3.37	3.52	3.46	3.41	3.41
	15	12.2	5.1	TC	68.4	62.7	57.3	53.7	71.2	65.3	60.0	58.5	72.8	66.8	62.2	61.8
				SHC	33.0	40.7	49.2	53.7	36.2	46.5	56.1	58.5	39.0	51.4	61.5	61.8
				kW	3.40	3.35	3.39	3.31	3.43	3.37	3.33	3.32	3.45	3.40	3.35	3.35
75	10	5.7	2.4	TC	66.1	60.4	55.2	52.2	68.7	63.0	58.0	56.8	70.1	64.4	60.1	59.9
				SHC	32.1	40.1	47.9	52.2	35.3	45.6	54.9	56.8	38.1	50.5	59.9	59.9
				kW	3.92	3.85	3.79	3.75	3.96	3.89	3.82	3.82	3.98	3.91	3.86	3.85
	12.5	9.1	3.8	TC	66.3	60.6	55.4	52.3	68.9	63.2	58.1	56.9	70.4	64.6	60.2	60.1
				SHC	32.2	40.2	48.0	52.3	35.4	45.7	55.0	56.9	38.2	50.6	60.1	60.1
				kW	3.81	3.75	3.70	3.67	3.85	3.79	3.73	3.72	3.87	3.81	3.76	3.76
	15	12.2	5.1	TC	66.4	60.7	55.4	52.4	69.1	63.3	58.2	57.0	70.5	64.7	60.4	60.2
				SHC	32.3	40.3	48.0	52.4	35.4	45.7	55.1	57.0	38.3	50.6	60.2	60.2
				kW	3.75	3.69	3.65	3.62	3.78	3.72	3.67	3.67	3.80	3.74	3.70	3.70
	17.5	16.3	6.8	TC	66.5	60.8	55.5	52.4	69.2	63.4	58.3	57.1	70.7	64.8	60.5	60.3
				SHC	32.3	40.3	48.0	52.4	35.5	45.7	55.1	57.1	38.3	50.7	60.2	60.3
				kW	3.70	3.65	3.61	3.58	3.73	3.68	3.63	3.62	3.75	3.70	3.66	3.66
85	10	5.7	2.4	TC	64.0	58.5	53.4	50.8	66.4	60.9	56.1	55.2	67.8	62.2	58.2	58.2
				SHC	31.4	39.3	47.0	50.8	34.5	44.7	53.9	55.2	37.3	49.6	58.2	58.2
				kW	4.32	4.25	4.19	4.16	4.36	4.30	4.23	4.13	4.38	4.31	4.26	4.26
	12.5	9.1	3.8	TC	64.2	58.7	53.6	50.9	66.7	61.1	56.2	55.3	68.1	62.4	58.4	58.4
				SHC	31.4	39.4	47.1	50.9	34.6	44.8	53.9	55.3	37.4	49.7	58.4	58.4
				kW	4.21	4.15	4.10	4.07	4.24	4.18	4.13	4.12	4.26	4.20	4.16	4.16
	15	12.2	5.1	TC	64.3	58.8	53.6	51.0	66.8	61.2	56.3	55.4	68.2	62.6	58.5	58.5
				SHC	31.5	39.4	47.1	51.0	34.6	44.9	54.0	55.4	37.6	49.8	58.5	58.5
				kW	4.14	4.08	4.04	4.01	4.17	4.11	4.06	4.06	4.19	4.13	4.09	4.09
	17.5	16.3	6.8	TC	64.4	58.9	53.7	51.0	66.9	61.3	56.4	55.5	68.3	62.6	58.6	58.6
				SHC	31.5	39.5	47.1	51.0	34.7	44.9	54.0	55.5	37.5	49.8	58.6	58.6
				kW	4.09	4.04	3.99	3.97	4.11	4.06	4.02	4.01	4.13	4.08	4.04	4.04
95	12.5	9.1	3.8	TC	62.0	56.6	51.7	49.4	64.3	58.9	54.2	53.6	65.6	60.1	56.5	56.5
				SHC	30.6	38.5	46.1	49.4	33.7	43.9	52.8	53.6	36.5	48.8	56.5	56.5
				kW	4.65	4.59	4.54	4.51	4.68	4.62	4.57	4.56	4.71	4.64	4.60	4.60
	15	12.2	5.1	TC	62.2	56.7	51.8	49.5	64.5	59.0	54.3	53.7	65.7	60.2	56.6	56.6
				SHC	30.7	38.6	46.2	49.5	33.8	44.0	52.8	53.7	36.6	48.8	56.6	56.6
				kW	4.57	4.52	4.47	4.45	4.60	4.55	4.50	4.49	4.62	4.57	4.53	4.53
	17.5	16.3	6.8	TC	62.2	56.8	51.9	49.5	64.6	59.0	54.4	53.8	65.8	60.3	56.7	56.7
				SHC	30.7	38.6	46.2	49.5	33.8	44.0	52.9	53.8	36.6	48.8	56.7	56.7
				kW	4.52	4.45	4.42	4.40	4.54	4.49	4.45	4.45	4.56	4.51	4.48	4.48

Shaded area in table indicates nominal cfm values.

LEGEND

- BF — Bypass Factor
- Ewb — Entering Wet Bulb
- EWT — Entering-Water Temperature (F)
- GPM — Gallons per minute
- kW — Compressor Motor Power Input (kilowatts)
- SHC — Sensible Heating Capacity (1000 Btuh)
- TC — Total Capacity (1000 Btuh), Gross

NOTES:

1. Water gpm values are calculated using a 0.0005 fouling factor.
2. Direct interpolation is permissible. Do not extrapolate.
3. Gross capacities do *not* include deduction for indoor-fan motor heat.
4. Ratings for 50BRN units are based on 15 F of subcooling. For 0° F subcooling, reduce capacity by 7.5%.
5. All combinations use R-22. Unless otherwise designated, ratings are at optimum charge.
6. SHC is based on 80 F db temperature of air entering the coil. Below 80 F db, subtract (corr factor x cfm) from SHC. Above 80 F db, add (corr factor x cfm) to SHC.

The following formulas may be used:

$$ldb = edb - \frac{\text{sensible capacity (Btuh)}}{1.10 \times \text{cfm}}$$

$$lwb = \text{Wet-bulb temperature corresponding to enthalpy of air leaving evaporator coil (} h_{lwb} \text{)}$$

$$h_{lwb} = h_{ewb} - \frac{\text{total capacity (Btuh)}}{4.5 \times \text{cfm}}$$

Where:

$$h_{ewb} = \text{Enthalpy of air entering evaporator coil.}$$

BYPASS FACTOR (BF)	ENTERING-AIR DRY-BULB TEMPERATURE (F)					
	79	78	77	76	75	under 75
	81	82	83	84	85	over 85
	Correction Factor					
.05	1.045	2.09	3.14	4.18	5.23	Use formula shown below.
.10	.99	1.98	2.97	3.96	4.95	
.20	.88	1.76	2.64	3.52	4.40	
.30	.77	1.54	2.31	3.08	3.85	
.35	.72	1.43	2.15	2.86	3.58	

$$\text{Correction Factor} = 1.10 \times (1 - \text{BF}) \times (\text{db} - 80).$$



GROSS COOLING CAPACITIES (cont)

50BRN008 UNIT

EWT (F)	GPM	PRESSURE DROP		AIR ENTERING EVAPORATOR — CFM/BF												
				2250 / 0.08				3000 / 0.11				3750 / 0.13				
		Ft	Psig	Air Entering Evaporator — Ewb (F)												
				72	67	62	57	72	67	62	57	72	67	62	57	
65	15	8.4	3.5	TC	92.3	84.5	77.3	73.7	95.7	87.8	81.1	79.9	97.6	89.6	84.1	84.1
				SHC	45.4	57.2	68.4	73.7	50.0	65.1	78.3	79.9	54.0	72.0	84.1	84.1
				kW	4.28	4.23	4.18	4.15	4.30	4.25	4.21	4.20	4.31	4.26	4.24	4.24
	18.8	12.4	5.2	TC	92.6	84.7	77.5	73.9	96.1	88.1	81.3	80.1	98.0	89.9	84.3	84.3
				SHC	45.5	57.2	68.5	73.9	50.1	65.2	78.4	80.1	54.2	72.1	84.3	84.3
				kW	4.13	4.09	4.06	4.04	4.14	4.11	4.08	4.08	4.15	4.12	4.10	4.10
	22.5	16.8	7.0	TC	92.8	84.9	77.6	74.0	96.3	88.4	81.5	80.3	98.2	90.2	84.5	84.5
				SHC	45.6	57.3	68.6	74.0	50.2	65.2	78.5	80.3	54.3	72.2	84.5	84.5
				kW	4.03	4.01	3.98	3.97	4.04	4.02	4.00	4.00	4.05	4.03	4.01	4.01
75	15	8.4	3.5	TC	89.5	81.9	75.0	71.9	92.8	85.1	78.6	77.8	94.4	86.7	81.8	81.8
				SHC	44.3	56.1	67.3	71.9	49.0	63.9	76.8	77.8	52.9	70.8	81.8	81.8
				kW	4.85	4.79	4.73	4.70	4.87	4.82	4.76	4.76	4.89	4.84	4.80	4.80
	18.8	12.4	5.2	TC	89.8	82.1	75.2	72.0	93.1	85.4	78.9	78.0	94.8	87.0	82.0	82.0
				SHC	44.4	56.1	67.4	72.0	49.0	64.3	76.9	78.0	53.0	70.9	82.0	82.0
				kW	4.69	4.64	4.60	4.58	4.71	4.67	4.63	4.62	4.72	4.68	4.65	4.65
	22.5	16.8	7.0	TC	90.0	82.3	75.3	72.1	93.3	85.6	79.0	78.1	95.0	87.2	82.2	82.1
				SHC	44.5	56.2	67.4	72.1	49.1	64.1	76.9	78.1	53.1	71.0	82.2	82.1
				kW	4.59	4.55	4.52	4.50	4.60	4.57	4.54	4.54	4.61	4.58	4.56	4.56
26.3	22.0	9.2	TC	90.1	82.4	75.4	72.2	93.5	85.7	79.1	78.3	95.2	87.3	82.3	82.3	
			SHC	44.6	56.3	67.5	72.2	49.2	64.1	77.0	78.3	53.2	71.0	82.3	82.3	
			kW	4.52	4.49	4.46	4.44	4.53	4.50	4.48	4.47	4.54	4.51	4.50	4.50	
85	15	8.4	3.5	TC	86.7	79.3	72.7	70.1	89.7	82.2	76.2	75.7	91.2	83.7	79.4	79.4
				SHC	43.3	55.0	66.1	70.1	47.9	62.8	75.2	75.7	51.8	69.6	79.4	79.4
				kW	5.46	5.39	5.32	5.29	5.50	5.42	5.36	5.35	5.52	5.45	5.40	5.40
	18.8	12.4	5.2	TC	86.9	79.5	72.9	70.2	90.0	82.5	76.4	75.9	91.5	84.0	79.6	79.6
				SHC	43.4	55.0	66.2	70.2	48.0	62.9	75.3	75.9	51.9	69.7	79.6	79.6
				kW	5.30	5.24	5.18	5.15	5.32	5.27	5.22	5.21	5.34	5.29	5.25	5.25
	22.5	16.8	7.0	TC	87.1	79.6	72.9	70.3	90.2	82.6	76.5	75.6	91.7	84.1	79.7	79.7
				SHC	43.4	55.1	66.2	70.3	48.1	62.9	75.4	75.6	52.0	69.7	79.7	79.7
				kW	5.19	5.14	5.09	5.07	5.22	5.17	5.13	5.12	5.23	5.18	5.15	5.15
26.3	22.0	9.2	TC	87.2	79.7	73.0	70.3	90.3	82.8	76.6	76.1	91.9	84.3	79.8	79.8	
			SHC	43.5	55.1	66.3	70.3	48.1	63.0	75.4	76.1	52.1	69.8	79.8	79.8	
			kW	5.12	5.07	5.03	5.01	5.13	5.09	5.06	5.05	5.15	5.11	5.08	5.08	
95	18.8	12.4	5.2	TC	83.9	76.8	70.4	68.3	86.8	79.5	73.9	73.7	88.1	80.9	77.2	77.2
				SHC	42.3	53.9	64.9	68.3	46.8	61.7	73.5	73.7	50.8	68.4	77.2	77.2
				kW	5.95	5.88	5.81	5.78	6.00	5.92	5.86	5.85	6.01	5.94	5.90	5.90
	22.5	16.8	7.0	TC	84.1	77.0	70.5	68.3	86.9	79.7	74.1	73.8	88.4	81.7	77.4	77.4
				SHC	42.3	54.0	65.0	68.3	46.9	61.7	73.6	73.8	50.8	68.4	77.4	77.4
				kW	5.84	5.78	5.72	5.69	5.87	5.81	5.76	5.76	5.89	5.83	5.80	5.80
	26.3	22.0	9.2	TC	84.2	77.1	70.6	68.4	87.1	79.8	74.1	73.9	88.5	81.2	77.4	77.4
				SHC	42.4	54.0	65.0	68.4	46.9	61.8	73.7	73.9	50.9	68.5	77.4	77.4
				kW	5.76	5.71	5.65	5.63	5.79	5.73	5.69	5.69	5.80	5.75	5.72	5.72

Shaded area in table indicates nominal cfm values.

LEGEND

- BF** — Bypass Factor
- Ewb** — Entering Wet Bulb
- EWT** — Entering-Water Temperature (F)
- GPM** — Gallons per minute
- kW** — Compressor Motor Power Input (kilowatts)
- SHC** — Sensible Heating Capacity (1000 Btuh)
- TC** — Total Capacity (1000 Btuh), Gross

NOTES:

1. Water gpm values are calculated using a 0.0005 fouling factor.
2. Direct interpolation is permissible. Do not extrapolate.
3. Gross capacities do *not* include deduction for indoor-fan motor heat.
4. Ratings for 50BRN units are based on 15 F of subcooling. For 0° F subcooling, reduce capacity by 7.5%.
5. All combinations use R-22. Unless otherwise designated, ratings are at optimum charge.
6. SHC is based on 80 F db temperature of air entering the coil. Below 80 F db, subtract (corr factor x cfm) from SHC. Above 80 F db, add (corr factor x cfm) to SHC.

The following formulas may be used:

$$ldb = edb - \frac{\text{sensible capacity (Btuh)}}{1.10 \times \text{cfm}}$$

$$lwb = \text{Wet-bulb temperature corresponding to enthalpy of air leaving evaporator coil (} h_{lwb} \text{)}$$

$$h_{lwb} = h_{ewb} - \frac{\text{total capacity (Btuh)}}{4.5 \times \text{cfm}}$$

Where:

$$h_{ewb} = \text{Enthalpy of air entering evaporator coil.}$$

BYPASS FACTOR (BF)	ENTERING-AIR DRY-BULB TEMPERATURE (F)					
	79	78	77	76	75	under 75
	81	82	83	84	85	over 85
	Correction Factor					
.05	1.045	2.09	3.14	4.18	5.23	Use formula shown below.
.10	.99	1.98	2.97	3.96	4.95	
.20	.88	1.76	2.64	3.52	4.40	
.30	.77	1.54	2.31	3.08	3.85	
.35	.72	1.43	2.15	2.86	3.58	

$$\text{Correction Factor} = 1.10 \times (1 - \text{BF}) \times (\text{db} - 80).$$

Performance data (cont)



GROSS COOLING CAPACITIES (cont)

50BRN012 UNIT

EWT (F)	GPM	PRESSURE DROP		AIR ENTERING EVAPORATOR — CFM/BF												
				3000 / 0.06				4000 / 0.08				5000 / 0.10				
		Ft	Psig	TC	Air Entering Evaporator — Ewb (F)											
					72	67	62	57	72	67	62	57	72	67	62	57
65	20	5.7	2.4	TC	134.4	123.1	112.6	106.1	139.7	128.3	118.3	115.5	142.6	131.2	122.4	121.9
				SHC	65.1	81.2	96.7	106.1	71.4	91.9	110.9	115.5	77.0	101.7	121.4	121.9
				kW	7.23	7.13	7.03	6.97	7.29	7.18	7.09	7.06	7.33	7.22	7.13	7.13
	25	9.1	3.8	TC	134.9	123.6	113.0	106.4	140.3	128.8	118.6	115.8	143.3	131.8	122.8	122.3
				SHC	65.3	81.3	96.9	106.4	71.6	92.1	111.1	115.8	77.2	101.9	121.7	122.3
				kW	7.01	6.92	6.84	6.79	7.06	6.97	6.89	6.87	7.09	7.00	6.93	6.92
	30	12.2	5.1	TC	135.3	123.8	113.2	106.6	140.7	129.1	118.9	115.9	143.7	132.1	123.1	122.5
				SHC	65.4	81.5	97.0	106.6	71.7	92.3	111.3	115.9	77.3	102.1	122.0	122.5
				kW	6.87	6.79	6.72	6.67	6.91	6.83	6.76	6.74	6.94	6.86	6.79	6.79
75	20	5.7	2.4	TC	130.6	119.5	109.2	103.4	135.6	124.4	114.6	112.4	138.3	127.1	118.8	118.6
				SHC	63.6	79.6	95.0	103.4	69.9	90.3	108.9	112.4	75.5	100.1	118.6	118.6
				kW	8.02	7.91	7.81	7.75	8.08	7.96	7.87	7.85	8.12	8.00	7.92	7.92
	25	9.1	3.8	TC	131.0	119.9	109.6	103.7	136.1	124.9	115.0	112.8	139.0	127.7	119.2	119.0
				SHC	63.8	79.8	95.2	103.7	70.1	90.5	109.1	112.8	75.6	100.2	118.9	119.0
				kW	7.77	7.68	7.60	7.55	7.82	7.73	7.65	7.63	7.85	7.76	7.69	7.69
	30	12.2	5.1	TC	131.3	120.1	109.9	103.9	136.5	125.2	115.2	113.0	139.3	128.0	119.5	119.5
				SHC	63.9	79.9	95.3	103.9	70.2	90.7	109.3	113.0	75.8	100.4	119.5	119.5
				kW	7.62	7.54	7.47	7.42	7.66	7.58	7.52	7.50	7.69	7.61	7.55	7.55
	35	16.3	6.8	TC	131.6	120.4	110.0	104.0	136.8	125.4	115.4	113.1	139.7	128.2	119.6	119.6
				SHC	64.0	80.0	95.4	104.0	70.3	90.8	109.4	113.1	75.9	100.5	119.4	119.6
				kW	7.51	7.43	7.37	7.33	7.54	7.47	7.41	7.39	7.57	7.49	7.44	7.44
85	20	5.7	2.4	TC	126.4	115.6	105.6	100.6	131.1	120.2	110.8	109.2	133.7	122.7	115.1	115.1
				SHC	62.1	77.9	93.2	100.6	68.3	88.7	106.7	109.2	73.8	98.3	115.1	115.1
				kW	8.90	8.79	8.68	8.63	8.96	8.85	8.75	8.74	9.01	8.88	8.81	8.81
	25	9.1	3.8	TC	126.9	116.1	106.0	100.8	131.7	120.7	111.2	109.6	134.3	123.2	115.5	115.5
				SHC	62.2	78.1	93.4	100.8	68.5	88.9	107.0	109.6	74.1	98.5	115.5	115.5
				kW	8.64	8.54	8.46	8.41	8.69	8.59	8.51	8.50	8.72	8.62	8.55	8.55
	30	12.2	5.1	TC	127.2	116.4	106.3	101.1	132.1	121.0	111.4	109.7	134.7	123.6	115.7	115.7
				SHC	62.4	78.2	93.5	101.1	68.6	88.9	107.1	109.7	74.2	98.6	115.7	115.7
				kW	8.47	8.39	8.31	8.27	8.51	8.43	8.36	8.34	8.53	8.45	8.40	8.40
	35	16.3	6.8	TC	127.5	116.5	106.4	101.1	132.4	121.3	111.6	109.9	135.0	123.9	115.9	115.9
				SHC	62.4	78.3	93.6	101.1	68.7	89.1	107.2	109.9	74.2	98.7	115.9	115.9
				kW	8.34	8.27	8.21	8.17	8.38	8.31	8.25	8.23	8.41	8.34	8.28	8.28
95	25	9.1	3.8	TC	122.5	111.9	102.1	97.8	126.9	116.2	107.1	106.0	129.4	118.6	111.8	111.8
				SHC	60.6	76.4	91.5	97.8	66.8	87.1	104.6	106.0	72.3	96.6	111.8	111.8
				kW	9.60	9.51	9.41	9.37	9.66	9.55	9.46	9.45	9.69	9.59	9.51	9.51
	30	12.2	5.1	TC	122.8	112.1	102.4	98.0	127.3	116.5	107.4	106.3	129.8	118.9	112.0	112.0
				SHC	60.7	76.5	91.6	98.0	66.9	87.2	104.7	106.3	72.4	96.7	112.0	112.0
				kW	9.42	9.33	9.26	9.22	9.46	9.37	9.30	9.29	9.49	9.40	9.35	9.35
	35	16.3	6.8	TC	123.0	112.4	102.6	98.1	127.6	116.8	107.6	106.5	130.0	119.1	112.2	112.2
				SHC	60.8	76.6	91.7	98.1	67.0	87.3	104.9	106.5	72.6	96.9	112.2	112.2
				kW	9.29	9.21	9.14	9.11	9.32	9.24	9.18	9.18	9.35	9.27	9.22	9.22

Shaded area in table indicates nominal cfm values.

LEGEND

- BF — Bypass Factor
- Ewb — Entering Wet Bulb
- EWT — Entering-Water Temperature (F)
- GPM — Gallons per minute
- kW — Compressor Motor Power Input (kilowatts)
- SHC — Sensible Heating Capacity (1000 Btuh)
- TC — Total Capacity (1000 Btuh), Gross

NOTES:

1. Water gpm values are calculated using a 0.0005 fouling factor.
2. Direct interpolation is permissible. Do not extrapolate.
3. Gross capacities do *not* include deduction for indoor-fan motor heat.
4. Ratings for 50BRN units are based on 15 F of subcooling. For 0° F subcooling, reduce capacity by 7.5%.
5. All combinations use R-22. Unless otherwise designated, ratings are at optimum charge.
6. SHC is based on 80 F db temperature of air entering the coil. Below 80 F db, subtract (corr factor x cfm) from SHC. Above 80 F db, add (corr factor x cfm) to SHC.

The following formulas may be used:

$$ldb = edb - \frac{\text{sensible capacity (Btuh)}}{1.10 \times \text{cfm}}$$

$$lwb = \text{Wet-bulb temperature corresponding to enthalpy of air leaving evaporator coil (} h_{lwb} \text{)}$$

$$h_{lwb} = h_{ewb} - \frac{\text{total capacity (Btuh)}}{4.5 \times \text{cfm}}$$

Where:

$$h_{ewb} = \text{Enthalpy of air entering evaporator coil.}$$

BYPASS FACTOR (BF)	ENTERING-AIR DRY-BULB TEMPERATURE (F)					
	79	78	77	76	75	under 75
	81	82	83	84	85	over 85
	Correction Factor					
.05	1.045	2.09	3.14	4.18	5.23	Use formula shown below.
.10	.99	1.98	2.97	3.96	4.95	
.20	.88	1.76	2.64	3.52	4.40	
.30	.77	1.54	2.31	3.08	3.85	
.35	.72	1.43	2.15	2.86	3.58	

$$\text{Correction Factor} = 1.10 \times (1 - \text{BF}) \times (\text{db} - 80).$$



GROSS COOLING CAPACITIES (cont)

50BRN014 UNIT

EWT (F)	GPM	PRESSURE DROP		AIR ENTERING EVAPORATOR — CFM/BF												
				3750 / 0.08				5000 / 0.10				6250 / 0.12				
		Ft	Psig	Air Entering Evaporator — Ewb (F)												
				72	67	62	57	72	67	62	57	72	67	62	57	
65	25	6.0	2.5	TC	158.9	145.4	132.9	126.1	165.1	151.3	139.2	136.7	168.5	154.6	144.3	144.1
				SHC	77.7	97.2	116.2	126.1	85.2	110.3	132.8	136.7	92.0	122.1	144.0	144.1
				kW	7.81	7.71	7.61	7.56	7.86	7.76	7.67	7.65	7.89	7.80	7.72	7.72
	31	9.1	3.8	TC	159.3	145.7	133.2	126.3	165.6	151.7	139.5	137.0	169.0	155.1	144.6	144.4
				SHC	77.8	97.4	116.3	126.3	85.4	110.4	132.9	137.0	92.2	122.1	144.3	144.4
				kW	7.57	7.49	7.41	7.37	7.61	7.53	7.46	7.45	7.64	7.56	7.50	7.50
	37.5	12.5	5.2	TC	159.6	146.0	133.4	126.4	165.9	151.9	139.7	137.1	169.3	155.3	144.8	144.8
				SHC	77.9	97.5	116.4	126.4	85.5	110.5	133.0	137.1	92.3	122.3	144.8	144.8
				kW	7.40	7.34	7.27	7.24	7.43	7.37	7.31	7.30	7.46	7.39	7.34	7.34
75	25	6.0	2.5	TC	154.2	141.1	129.1	123.0	160.0	146.5	135.2	133.2	163.1	149.7	140.2	140.2
				SHC	75.9	95.4	114.3	123.0	83.4	108.3	130.4	133.2	90.2	120.0	140.2	140.2
				kW	8.76	8.64	8.53	8.47	8.81	8.70	8.60	8.60	8.85	8.74	8.66	8.66
	31	9.1	3.8	TC	154.5	141.4	129.3	123.2	160.4	146.9	135.4	133.5	163.6	149.9	140.5	140.5
				SHC	76.0	95.5	114.4	123.2	83.5	108.5	130.6	133.5	90.3	120.2	140.5	140.5
				kW	8.50	8.41	8.31	8.27	8.55	8.46	8.38	8.36	8.58	8.49	8.42	8.42
	37.5	12.5	5.2	TC	154.9	141.6	129.5	123.4	160.7	147.2	135.6	133.7	164.0	150.2	140.7	140.7
				SHC	76.1	95.6	114.5	123.4	83.7	108.6	130.7	133.7	90.4	120.3	140.7	140.7
				kW	8.32	8.25	8.17	8.13	8.36	8.29	8.21	8.20	8.39	8.31	8.25	8.25
	44	16.3	6.8	TC	155.0	141.8	129.7	123.5	161.0	147.4	135.8	133.8	164.2	150.5	140.9	140.8
				SHC	76.2	95.7	114.5	123.5	83.7	108.6	130.8	133.8	90.5	120.4	140.9	140.8
				kW	8.19	8.11	8.06	8.02	8.23	8.16	8.10	8.10	8.25	8.18	8.14	8.14
85	25	6.0	2.5	TC	149.4	136.7	125.0	119.8	154.6	141.7	130.9	129.6	157.5	144.4	136.3	136.3
				SHC	74.1	93.6	112.2	119.8	81.5	106.3	127.8	129.6	88.2	117.9	136.3	136.3
				kW	9.81	9.66	9.54	9.48	9.87	9.73	9.62	9.61	9.91	9.79	9.69	9.69
	31	9.1	3.8	TC	149.8	137.0	125.3	120.0	155.0	142.0	131.2	129.8	157.9	144.8	136.6	136.6
				SHC	74.2	93.7	112.3	120.0	81.6	106.5	127.9	129.8	88.4	118.0	136.6	136.6
				kW	9.53	9.42	9.31	9.26	9.58	9.48	9.38	9.37	9.61	9.51	9.44	9.44
	37.5	12.5	5.2	TC	150.0	137.3	125.5	120.2	155.4	142.3	131.4	130.0	158.2	145.1	136.7	136.7
				SHC	74.3	93.8	112.4	120.2	81.7	106.6	128.1	130.0	88.5	118.1	136.7	136.7
				kW	9.33	9.24	9.15	9.11	9.38	9.29	9.21	9.20	9.41	9.32	9.26	9.26
	44	16.3	6.8	TC	150.2	137.4	125.6	120.2	155.6	142.5	131.6	130.1	158.5	145.3	136.9	136.9
				SHC	74.3	93.8	112.5	120.2	81.8	106.7	128.2	130.1	88.6	118.2	136.9	136.9
				kW	9.20	9.12	9.04	9.00	9.24	9.16	9.09	9.09	9.26	9.18	9.13	9.13
95	31	9.1	3.8	TC	144.8	132.4	121.1	116.6	149.6	137.0	126.8	126.0	152.2	139.6	132.4	132.4
				SHC	72.3	91.7	110.2	116.6	79.7	104.5	125.1	126.0	86.3	115.9	132.4	132.4
				kW	10.65	10.53	10.40	10.36	10.71	10.59	10.48	10.47	10.75	10.63	10.55	10.55
	37.5	12.5	5.2	TC	145.1	132.6	121.3	116.8	149.9	137.3	127.0	126.2	152.5	139.8	132.6	132.6
				SHC	72.4	91.8	110.3	116.8	79.8	104.6	125.3	126.2	86.5	116.0	132.6	132.6
				kW	10.44	10.34	10.23	10.19	10.50	10.39	10.30	10.30	10.52	10.42	10.36	10.36
	44	16.3	6.8	TC	145.3	132.8	121.4	116.9	150.1	137.5	127.1	126.3	152.8	140.0	132.7	132.7
				SHC	72.5	91.9	110.3	116.9	79.8	104.6	125.3	126.3	86.6	116.1	132.7	132.7
				kW	10.30	10.20	10.11	10.07	10.35	10.25	10.16	10.16	10.37	10.28	10.23	10.23

Shaded area in table indicates nominal cfm values.

LEGEND

- BF** — Bypass Factor
- Ewb** — Entering Wet Bulb
- EWT** — Entering-Water Temperature (F)
- GPM** — Gallons per minute
- kW** — Compressor Motor Power Input (kilowatts)
- SHC** — Sensible Heating Capacity (1000 Btuh)
- TC** — Total Capacity (1000 Btuh), Gross

NOTES:

1. Water gpm values are calculated using a 0.0005 fouling factor.
2. Direct interpolation is permissible. Do not extrapolate.
3. Gross capacities do *not* include deduction for indoor-fan motor heat.
4. Ratings for 50BRN units are based on 15 F of subcooling. For 0° F subcooling, reduce capacity by 7.5%.
5. All combinations use R-22. Unless otherwise designated, ratings are at optimum charge.
6. SHC is based on 80 F db temperature of air entering the coil. Below 80 F db, subtract (corr factor x cfm) from SHC. Above 80 F db, add (corr factor x cfm) to SHC.

The following formulas may be used:

$$ldb = edb - \frac{\text{sensible capacity (Btuh)}}{1.10 \times \text{cfm}}$$

$$lwb = \text{Wet-bulb temperature corresponding to enthalpy of air leaving evaporator coil } (h_{lwb})$$

$$h_{lwb} = h_{ewb} - \frac{\text{total capacity (Btuh)}}{4.5 \times \text{cfm}}$$

Where:

$$h_{ewb} = \text{Enthalpy of air entering evaporator coil.}$$

BYPASS FACTOR (BF)	ENTERING-AIR DRY-BULB TEMPERATURE (F)					
	79	78	77	76	75	under 75
	81	82	83	84	85	over 85
	Correction Factor					
.05	1.045	2.09	3.14	4.18	5.23	Use formula shown below.
.10	.99	1.98	2.97	3.96	4.95	
.20	.88	1.76	2.64	3.52	4.40	
.30	.77	1.54	2.31	3.08	3.85	
.35	.72	1.43	2.15	2.86	3.58	

$$\text{Correction Factor} = 1.10 \times (1 - \text{BF}) \times (\text{db} - 80).$$

Performance data (cont)



GROSS COOLING CAPACITIES (cont)

50BRN016 UNIT

EWT (F)	GPM	PRESSURE DROP		AIR ENTERING EVAPORATOR — CFM/BF												
				4500 / 0.09				6000 / 0.12				7500 / 0.14				
		Ft	Psig	Air Entering Evaporator — Ewb (F)												
				72	67	62	57	72	67	62	57	72	67	62	57	
65	30	8.4	3.5	TC	184.3	168.7	154.3	147.4	190.9	175.0	161.6	159.5	194.5	178.5	167.8	167.8
				SHC	90.8	114.3	137.0	147.4	99.8	129.9	156.3	159.5	107.9	143.9	167.8	167.8
				kW	8.73	8.63	8.53	8.48	8.79	8.69	8.59	8.58	8.82	8.72	8.65	8.65
	37.5	12.4	5.2	TC	184.8	169.1	154.7	147.7	191.5	175.6	161.9	159.8	195.2	179.0	168.2	168.2
				SHC	91.0	114.5	137.1	147.7	100.0	130.1	156.5	159.8	108.1	144.1	168.2	168.2
				kW	8.45	8.37	8.30	8.25	8.48	8.41	8.34	8.33	8.50	8.43	8.38	8.38
	45	16.8	7.0	TC	185.1	169.3	154.8	147.9	192.0	175.9	162.2	160.0	195.7	179.5	168.5	168.5
				SHC	91.1	114.6	137.3	147.9	100.2	130.3	156.7	160.0	108.3	144.3	168.5	168.5
				kW	8.25	8.19	8.13	8.10	8.28	8.23	8.17	8.16	8.29	8.24	8.20	8.20
75	30	8.4	3.5	TC	178.6	163.5	149.8	143.8	184.8	169.4	156.7	155.3	188.2	172.6	163.2	163.2
				SHC	88.6	112.2	134.7	143.8	97.6	127.7	153.3	155.3	105.8	141.5	163.2	163.2
				kW	9.89	9.76	9.63	9.57	9.95	9.82	9.71	9.70	9.99	9.86	9.79	9.79
	37.5	12.4	5.2	TC	179.2	163.9	150.1	144.0	185.5	170.0	157.1	155.6	188.8	173.1	163.5	163.5
				SHC	88.8	112.3	134.8	144.0	97.8	127.9	153.5	155.6	105.9	141.8	163.5	163.5
				kW	9.58	9.48	9.39	9.34	9.63	9.54	9.45	9.43	9.66	9.57	9.50	9.50
	45	16.8	7.0	TC	179.5	164.2	150.3	144.2	185.9	170.2	157.3	155.8	189.3	173.6	163.8	163.8
				SHC	88.9	112.4	134.9	144.2	98.0	128.0	153.7	155.8	106.1	141.8	163.8	163.8
				kW	9.38	9.30	9.22	9.18	9.42	9.34	9.27	9.26	9.44	9.37	9.31	9.31
	52	22.0	9.2	TC	179.8	164.4	150.5	144.3	186.2	170.5	157.5	156.0	189.6	173.9	164.0	164.0
				SHC	89.1	112.5	135.0	144.3	98.1	128.1	153.7	156.0	106.2	141.9	164.0	164.0
				kW	9.24	9.17	9.10	9.07	9.27	9.20	9.14	9.14	9.29	9.23	9.18	9.18
85	30	8.4	3.7	TC	172.9	158.4	145.1	140.0	178.6	163.7	151.9	151.0	181.7	166.7	158.5	158.5
				SHC	86.5	110.0	132.3	140.0	95.5	125.4	150.1	151.0	103.5	139.0	158.5	158.5
				kW	11.15	10.98	10.83	10.76	11.22	11.06	10.92	10.91	11.26	11.11	11.02	11.02
	37.5	12.4	5.2	TC	173.5	158.8	145.4	140.3	179.2	164.2	152.3	151.4	182.3	167.1	158.9	158.9
				SHC	86.7	110.2	132.5	140.3	95.7	125.5	150.4	151.4	103.7	139.2	158.9	158.9
				kW	10.82	10.69	10.57	10.51	10.88	10.75	10.65	10.64	10.91	10.79	10.72	10.72
	45	16.8	7.0	TC	173.7	159.0	145.7	140.5	179.5	164.5	152.5	151.6	182.7	167.4	159.1	159.1
				SHC	86.8	110.3	132.6	140.5	95.8	125.7	150.5	151.6	103.9	139.4	159.1	159.1
				kW	10.60	10.50	10.39	10.34	10.65	10.55	10.46	10.45	10.68	10.58	10.52	10.52
	52	22.0	9.2	TC	173.9	159.2	145.8	140.6	179.8	164.7	152.7	151.7	183.0	167.7	159.3	159.3
				SHC	86.9	110.3	132.6	140.6	95.9	125.8	150.6	151.7	103.9	139.5	159.3	159.3
				kW	10.45	10.36	10.26	10.22	10.49	10.41	10.32	10.32	10.52	10.43	10.38	10.38
95	37.5	12.4	5.2	TC	167.7	153.4	140.6	136.4	172.8	158.4	147.3	146.9	175.5	161.1	154.0	154.0
				SHC	84.6	108.0	130.0	136.4	93.4	123.2	146.7	146.9	101.4	136.7	154.0	154.0
				kW	12.16	12.00	11.83	11.79	12.23	12.07	11.95	11.94	12.27	12.12	12.04	12.04
	45	16.8	7.0	TC	167.9	153.7	140.8	136.6	173.1	158.6	147.5	147.1	175.9	161.4	154.3	154.3
				SHC	84.7	108.1	130.1	136.6	93.4	123.3	146.9	147.1	101.6	136.8	154.3	154.3
				kW	11.93	11.79	11.66	11.61	11.99	11.86	11.75	11.74	12.04	11.90	11.83	11.83
	52	22.0	9.2	TC	168.2	153.9	140.9	136.7	173.4	158.9	147.7	147.3	176.2	161.7	154.4	154.4
				SHC	84.7	108.1	130.2	136.7	93.6	123.4	147.7	147.3	101.6	136.9	154.4	154.4
				kW	11.77	11.65	11.53	11.48	11.83	11.71	11.61	11.61	11.86	11.74	11.69	11.69

Shaded area in table indicates nominal cfm values.

LEGEND

- BF — Bypass Factor
- Ewb — Entering Wet Bulb
- EWT — Entering-Water Temperature (F)
- GPM — Gallons per minute
- kW — Compressor Motor Power Input (kilowatts)
- SHC — Sensible Heating Capacity (1000 Btuh)
- TC — Total Capacity (1000 Btuh), Gross

NOTES:

1. Water gpm values are calculated using a 0.0005 fouling factor.
2. Direct interpolation is permissible. Do not extrapolate.
3. Gross capacities do *not* include deduction for indoor-fan motor heat.
4. Ratings for 50BRN units are based on 15 F of subcooling. For 0° F subcooling, reduce capacity by 7.5%.
5. All combinations use R-22. Unless otherwise designated, ratings are at optimum charge.
6. SHC is based on 80 F db temperature of air entering the coil. Below 80 F db, subtract (corr factor x cfm) from SHC. Above 80 F db, add (corr factor x cfm) to SHC.

The following formulas may be used:

$$ldb = edb - \frac{\text{sensible capacity (Btuh)}}{1.10 \times \text{cfm}}$$

$$lwb = \text{Wet-bulb temperature corresponding to enthalpy of air leaving evaporator coil (} h_{lwb} \text{)}$$

$$h_{lwb} = h_{ewb} - \frac{\text{total capacity (Btuh)}}{4.5 \times \text{cfm}}$$

Where:

h_{ewb} = Enthalpy of air entering evaporator coil.

BYPASS FACTOR (BF)	ENTERING-AIR DRY-BULB TEMPERATURE (F)					
	79	78	77	76	75	under 75
	81	82	83	84	85	over 85
	Correction Factor					
.05	1.045	2.09	3.14	4.18	5.23	Use formula shown below.
.10	.99	1.98	2.97	3.96	4.95	
.20	.88	1.76	2.64	3.52	4.40	
.30	.77	1.54	2.31	3.08	3.85	
.35	.72	1.43	2.15	2.86	3.58	

Correction Factor = 1.10 x (1 - BF) x (db - 80).



GROSS COOLING CAPACITIES (cont)

50BRN024 UNIT

EWT (F)	GPM	PRESSURE DROP		Air Entering Evaporator — CFM / BF												
				6000 / 0.06				8000 / 0.08				10000 / 0.10				
				Air Entering Evaporator — Wet Bulb Temperature — Ewb (F)												
				72	67	62	57	72	67	62	57	72	67	62	57	
65	40	3.9	1.69	TC	260.0	239.3	219.9	205.7	272.6	250.7	230.3	223.7	281.2	258.7	238.7	237.3
				SHC	135.2	162.8	190.7	205.7	148.5	183.5	217.4	223.7	160.6	202.5	238.7	237.3
				kW	16.0	15.8	15.6	15.3	17.3	17.1	16.8	16.6	18.7	18.5	18.1	18.0
	50	6.2	2.69	TC	261.4	240.5	221.0	206.4	274.2	252.1	231.4	213.2	282.8	260.2	239.8	238.3
				SHC	135.8	163.4	191.2	206.4	149.1	184.1	218.0	213.2	161.2	203.1	239.8	238.3
				kW	15.7	15.5	15.3	15.1	17.0	16.7	16.5	16.3	18.4	18.2	17.9	17.7
	60	8.8	3.81	TC	262.2	241.7	221.6	206.8	275.2	252.9	232.2	225.2	283.9	261.1	240.5	238.9
				SHC	136.2	163.7	191.5	206.8	149.6	184.5	218.4	225.2	161.6	203.5	240.5	238.9
				kW	15.5	15.3	15.2	14.9	16.8	16.6	16.4	16.2	18.2	18.0	17.7	17.5
	70	11.9	5.16	TC	262.8	241.7	222.0	207.1	275.8	253.5	232.7	225.6	284.7	261.7	241.0	239.3
				SHC	136.4	163.9	191.8	207.1	149.6	184.8	218.6	225.6	161.9	203.8	241.0	239.3
				kW	15.4	15.2	15.0	14.8	16.6	16.5	16.2	16.1	18.1	17.9	17.6	17.4
75	40	3.9	1.69	TC	252.0	231.8	213.2	200.6	263.8	242.6	223.2	217.9	271.9	250.0	232.2	230.8
				SHC	131.9	159.4	187.3	200.6	145.1	180.0	213.5	217.9	157.0	198.8	232.2	230.8
				kW	17.9	17.6	17.4	17.1	19.2	18.9	18.6	18.4	20.7	20.4	20.0	19.9
	50	6.2	2.69	TC	253.4	232.9	214.2	201.4	265.4	249.0	224.4	218.8	273.7	251.5	233.2	231.9
				SHC	132.5	159.9	187.8	201.4	145.7	180.6	214.1	218.8	157.7	199.5	232.9	231.9
				kW	17.5	17.3	17.1	16.8	18.8	18.6	18.3	18.1	20.3	20.1	19.7	19.5
	60	8.8	3.81	TC	254.3	233.7	214.9	201.8	266.4	243.4	224.9	219.4	274.7	252.5	233.9	232.6
				SHC	132.9	160.3	188.1	201.8	146.1	179.9	214.4	219.4	158.1	199.9	233.9	232.6
				kW	17.2	17.1	16.9	16.7	18.6	18.4	18.1	17.9	20.1	19.8	19.4	19.3
	70	11.9	5.16	TC	254.9	234.3	215.3	203.6	267.1	244.0	225.3	219.8	275.5	253.2	234.4	233.0
				SHC	133.1	160.5	188.4	203.6	146.4	180.2	214.6	219.8	158.4	200.2	232.2	233.0
				kW	17.2	17.0	16.8	16.6	18.5	18.2	18.0	17.8	19.9	19.7	19.3	19.2
85	40	3.9	1.69	TC	243.5	224.3	206.2	195.5	254.7	234.5	216.0	212.0	262.1	241.0	225.4	224.1
				SHC	128.4	156.0	183.7	195.4	141.5	176.5	209.3	211.9	153.3	195.1	225.4	224.1
				kW	20.0	19.7	19.3	19.1	21.3	21.0	20.6	20.5	22.8	22.5	22.0	21.9
	50	6.2	2.69	TC	245.0	225.5	207.3	196.2	256.4	235.9	217.2	212.9	263.9	242.5	226.5	225.2
				SHC	129.0	156.5	184.2	196.2	142.1	177.1	210.0	212.9	154.0	195.7	226.5	225.2
				kW	19.6	19.3	19.0	18.8	20.9	20.6	20.3	20.1	22.4	22.1	21.6	21.5
	60	8.8	3.81	TC	245.9	226.3	208.0	196.7	257.4	236.7	217.9	213.5	265.1	243.4	227.2	225.9
				SHC	129.4	156.9	184.6	196.7	142.6	177.5	210.5	213.5	154.4	196.9	227.2	226.4
				kW	19.4	19.1	18.9	18.6	20.7	20.4	20.1	19.9	22.2	21.9	21.5	21.4
	70	11.9	5.16	TC	246.6	226.8	208.4	197.0	258.1	237.3	218.4	213.9	265.8	244.1	227.7	226.4
				SHC	129.6	157.1	184.8	197.0	142.8	177.7	210.7	213.9	154.8	196.4	227.5	226.4
				kW	19.2	19.0	18.7	18.5	20.5	20.3	20.0	19.8	22.0	21.7	21.3	21.2
95	40	3.9	1.69	TC	235.0	216.6	199.1	189.9	245.4	226.1	206.8	205.8	251.9	232.0	218.2	217.3
				SHC	124.9	152.6	180.1	189.9	137.9	172.9	206.7	205.7	149.5	191.4	217.8	217.3
				kW	19.2	19.0	18.7	18.5	23.6	23.2	22.7	22.6	25.0	24.7	24.1	24.0
	50	6.2	2.69	TC	236.4	217.8	200.2	190.7	247.1	227.6	211.0	206.8	253.8	233.5	219.4	218.4
				SHC	125.5	153.1	180.6	190.6	138.5	173.6	206.9	206.8	150.2	192.0	219.0	218.4
				kW	21.8	21.5	21.1	20.9	23.2	22.8	22.4	22.2	24.6	24.3	23.8	23.7
	60	8.8	3.81	TC	273.3	218.6	200.9	191.3	248.1	228.5	209.8	207.4	254.1	234.5	220.2	219.1
				SHC	125.9	153.5	180.8	191.3	138.9	173.9	206.6	207.3	150.6	192.4	220.0	219.1
				kW	21.5	21.2	20.9	20.7	22.9	22.6	22.2	22.1	24.4	24.1	23.5	23.6
	70	11.9	5.16	TC	237.9	219.1	201.4	191.6	248.8	229.1	210.6	207.9	255.8	235.2	220.6	219.5
				SHC	126.1	153.7	181.2	191.4	139.2	174.2	206.7	207.9	150.9	192.7	220.4	219.5
				kW	21.4	21.1	20.8	20.5	22.7	22.4	22.1	21.9	24.2	23.9	23.4	23.3

Shaded area in table indicates nominal cfm values.

LEGEND

- BF — Bypass Factor
- Ewb — Entering Wet Bulb
- EWT — Entering-Water Temperature (F)
- GPM — Gallons per minute
- kW — Compressor Motor Power Input (kilowatts)
- SHC — Sensible Heating Capacity (1000 Btuh)
- TC — Total Capacity (1000 Btuh), Gross

NOTES:

1. Water gpm values are calculated using a 0.0005 fouling factor.
2. Direct interpolation is permissible. Do not extrapolate.
3. Gross capacities do *not* include deduction for indoor-fan motor heat.
4. Ratings for 50BRN units are based on 15 F of subcooling. For 0° F subcooling, reduce capacity by 7.5%.
5. All combinations use R-22. Unless otherwise designated, ratings are at optimum charge.
6. SHC is based on 80 F db temperature of air entering the coil. Below 80 F db, subtract (corr factor x cfm) from SHC. Above 80 F db, add (corr factor x cfm) to SHC.

The following formulas may be used:

$$ldb = edb - \frac{\text{sensible capacity (Btuh)}}{1.10 \times \text{cfm}}$$

$$lwb = \text{Wet-bulb temperature corresponding to enthalpy of air leaving evaporator coil } (h_{lwb})$$

$$h_{lwb} = h_{ewb} - \frac{\text{total capacity (Btuh)}}{4.5 \times \text{cfm}}$$

Where:

$$h_{ewb} = \text{Enthalpy of air entering evaporator coil.}$$

BYPASS FACTOR (BF)	ENTERING-AIR DRY-BULB TEMPERATURE (F)					
	79	78	77	76	75	under 75
	81	82	83	84	85	over 85
	Correction Factor					
.05	1.045	2.09	3.14	4.18	5.23	Use formula shown below.
.10	.99	1.98	2.97	3.96	4.95	
.20	.88	1.76	2.64	3.52	4.40	
.30	.77	1.54	2.31	3.08	3.85	
.40	.66	1.32	2.09	2.86	3.63	
.50	.55	1.10	1.87	2.64	3.41	

$$\text{Correction Factor} = 1.10 \times (1 - \text{BF}) \times (\text{db} - 80).$$

Performance data (cont)



GROSS COOLING CAPACITIES (cont) 50BZN006 UNIT WITH 09BY006 CONDENSER

TEMP (F) AIR ENTERING CONDENSER (Edb)		AIR ENTERING EVAPORATOR — CFM/BF											
		1500 / 0.08				2000 / 0.10				2500 / 0.13			
		Air Entering Evaporator — Ewb (F)											
		72	67	62	57	72	67	62	57	72	67	62	57
65	TC	69.2	63.3	57.8	54.5	71.1	65.0	59.8	58.7	73.4	67.3	62.8	62.8
	SHC	34.4	42.3	50.0	54.5	37.6	47.8	56.9	58.7	41.2	53.4	62.6	62.8
	kW	6.80	6.67	6.55	6.44	8.16	7.99	7.83	7.72	8.27	8.10	7.95	7.86
75	TC	66.7	61.0	55.6	52.8	69.2	63.4	58.4	57.5	71.4	65.5	61.4	61.4
	SHC	33.4	41.4	49.0	52.8	37.0	47.1	56.1	57.5	40.5	52.7	61.3	61.4
	kW	7.37	7.22	7.07	6.96	8.10	7.93	7.77	7.67	8.21	8.04	7.90	7.80
85	TC	64.2	58.7	53.5	51.2	67.4	61.8	57.0	56.3	69.4	63.8	60.0	60.1
	SHC	32.5	40.4	47.9	51.2	36.3	46.5	55.3	56.3	39.8	52.0	60.0	60.1
	kW	7.94	7.76	7.59	7.47	8.04	7.87	7.71	7.61	8.16	7.98	7.84	7.75
95	TC	61.5	56.1	51.3	49.4	64.5	59.0	54.6	54.3	66.7	61.3	57.7	57.7
	SHC	31.5	39.3	46.8	49.4	35.3	45.4	53.8	54.3	38.9	51.0	57.7	57.7
	kW	8.56	8.35	8.16	8.03	8.67	8.47	8.28	8.18	8.46	8.27	8.43	8.43
105	TC	58.6	53.5	48.9	47.6	61.3	56.2	52.2	52.2	63.1	58.0	55.4	55.9
	SHC	30.4	38.3	45.6	47.6	34.1	44.2	52.1	52.2	37.6	49.6	55.4	55.9
	kW	9.22	8.98	8.75	8.62	9.34	9.10	8.90	8.90	9.47	9.23	9.06	8.65
115	TC	55.6	50.8	46.4	45.6	58.1	53.2	49.8	50.0	59.7	54.9	52.9	53.1
	SHC	29.3	37.1	44.2	45.6	33.1	43.0	49.8	50.0	36.5	48.3	52.9	53.1
	kW	9.93	9.64	9.37	9.24	10.1	9.78	9.55	9.45	10.2	9.91	9.74	9.63
125	TC	52.4	47.8	43.9	43.5	54.6	50.1	47.4	47.6	56.1	51.7	50.3	50.5
	SHC	28.2	35.9	42.8	43.5	31.8	41.8	47.4	47.6	35.3	46.9	50.3	50.5
	kW	10.7	10.3	10.0	9.87	10.8	10.5	10.2	10.1	10.9	10.6	10.4	10.3

Shaded area in table indicates nominal cfm values.

LEGEND

- BF** — Bypass Factor
- Edb** — Entering Dry Bulb
- Ewb** — Entering Wet Bulb
- kW** — Compressor Motor Power Input (kilowatts)
- SHC** — Sensible Heating Capacity (1000 Btuh)
- TC** — Total Capacity (1000 Btuh), Gross

NOTES:

1. Water gpm values are calculated using a 0.0005 fouling factor.
2. Direct interpolation is permissible. Do not extrapolate.
3. Gross capacities do *not* include deduction for indoor-fan motor heat.
4. Ratings for 50BZN units are based on 15 F of subcooling. For 0° F subcooling, reduce capacity by 7.5%.
5. All combinations use R-22. Unless otherwise designated, ratings are at optimum charge.
6. SHC is based on 80 F db temperature of air entering the coil. Below 80 F db, subtract (corr factor x cfm) from SHC. Above 80 F db, add (corr factor x cfm) to SHC.

The following formulas may be used:

$$ldb = edb - \frac{\text{sensible capacity (Btuh)}}{1.10 \times \text{cfm}}$$

$$lwb = \text{Wet-bulb temperature corresponding to enthalpy of air leaving evaporator coil } (h_{lwb})$$

$$h_{lwb} = h_{ewb} - \frac{\text{total capacity (Btuh)}}{4.5 \times \text{cfm}}$$

Where:

h_{ewb} = Enthalpy of air entering evaporator coil.

BYPASS FACTOR (BF)	ENTERING-AIR DRY-BULB TEMPERATURE (F)					
	79	78	77	76	75	under 75
	81	82	83	84	85	over 85
	Correction Factor					
.05	1.045	2.09	3.14	4.18	5.23	Use formula shown below.
.10	.99	1.98	2.97	3.96	4.95	
.20	.88	1.76	2.64	3.52	4.40	
.30	.77	1.54	2.31	3.08	3.85	
.35	.72	1.43	2.15	2.86	3.58	

$$\text{Correction Factor} = 1.10 \times (1 - \text{BF}) \times (\text{db} - 80).$$



GROSS COOLING CAPACITIES (cont)
50BZN008 UNIT WITH 09BY008 CONDENSER

TEMP (F) AIR ENTERING CONDENSER (Edb)		AIR ENTERING EVAPORATOR — CFM/BF											
		2250 / 0.08				3000 / 0.11				3750 / 0.13			
		Air Entering Evaporator — Ewb (F)											
		72	67	62	57	72	67	62	57	72	67	62	57
65	TC	93.6	86.5	79.7	76.6	97.4	90.2	83.9	83.1	99.8	92.6	87.8	87.8
	SHC	47.7	59.8	71.4	76.6	53.1	68.6	81.8	83.1	58.1	76.5	87.8	87.8
	kW	6.35	6.23	6.07	6.02	6.67	6.55	6.40	6.39	6.96	6.83	6.71	6.71
75	TC	90.5	83.4	77.1	74.4	94.0	86.9	81.2	80.8	96.3	89.1	85.2	85.2
	SHC	46.5	58.6	70.1	74.4	51.9	67.3	80.1	80.8	56.9	75.1	85.2	85.2
	kW	7.04	6.85	6.72	6.62	7.37	7.18	7.06	7.06	7.67	7.47	7.39	7.39
85	TC	87.3	80.6	74.6	72.3	90.6	83.7	78.6	78.2	92.6	85.9	82.6	82.4
	SHC	45.3	57.4	68.8	72.3	50.7	66.0	78.2	78.2	55.6	73.7	82.6	82.4
	kW	7.79	7.57	7.42	7.32	8.13	7.90	7.78	7.72	8.42	8.21	8.14	8.09
95	TC	83.8	77.6	71.7	70.1	86.7	80.5	75.7	75.7	88.6	82.5	79.6	79.6
	SHC	44.0	56.2	67.3	70.1	49.4	64.7	75.7	75.7	54.3	72.3	79.6	79.6
	kW	8.53	8.33	8.10	8.07	8.88	8.68	8.48	8.48	9.18	8.99	8.86	8.86
105	TC	80.2	74.3	68.8	67.8	82.9	76.9	72.9	72.9	84.6	78.8	76.6	76.6
	SHC	42.8	54.8	65.7	67.8	48.1	63.2	72.9	72.9	53.0	70.6	76.6	76.6
	kW	9.37	9.13	8.90	8.89	9.72	9.48	9.31	9.31	10.0	9.80	9.70	9.69
115	TC	76.5	70.8	65.8	65.1	79.0	73.3	70.0	70.0	80.6	75.0	73.4	73.4
	SHC	41.5	53.4	64.1	65.1	46.7	61.7	70.0	70.0	51.6	68.9	73.4	73.4
	kW	10.2	9.94	9.72	9.68	10.6	10.3	10.2	10.1	10.9	10.6	10.6	10.6
125	TC	72.8	67.3	62.8	62.2	75.0	69.5	67.1	67.1	76.4	71.2	70.3	70.1
	SHC	40.1	52.0	62.3	62.2	45.4	60.2	67.1	67.1	50.2	67.2	70.3	70.1
	kW	11.1	10.8	10.6	10.4	11.5	11.2	11.1	11.1	11.8	11.5	11.5	11.4

Shaded area in table indicates nominal cfm values.

LEGEND

- BF** — Bypass Factor
- Edb** — Entering Dry Bulb
- Ewb** — Entering Wet Bulb
- kW** — Compressor Motor Power Input (kilowatts)
- SHC** — Sensible Heating Capacity (1000 Btuh)
- TC** — Total Capacity (1000 Btuh), Gross

NOTES:

1. Water gpm values are calculated using a 0.0005 fouling factor.
2. Direct interpolation is permissible. Do not extrapolate.
3. Gross capacities do *not* include deduction for indoor-fan motor heat.
4. Ratings for 50BZN units are based on 15 F of subcooling. For 0° F subcooling, reduce capacity by 7.5%.
5. All combinations use R-22. Unless otherwise designated, ratings are at optimum charge.
6. SHC is based on 80 F db temperature of air entering the coil. Below 80 F db, subtract (corr factor x cfm) from SHC. Above 80 F db, add (corr factor x cfm) to SHC.

The following formulas may be used:

$$l_{db} = e_{db} - \frac{\text{sensible capacity (Btuh)}}{1.10 \times \text{cfm}}$$

$$l_{wb} = \text{Wet-bulb temperature corresponding to enthalpy of air leaving evaporator coil } (h_{lwb})$$

$$h_{lwb} = h_{ewb} - \frac{\text{total capacity (Btuh)}}{4.5 \times \text{cfm}}$$

Where:

$$h_{ewb} = \text{Enthalpy of air entering evaporator coil.}$$

BYPASS FACTOR (BF)	ENTERING-AIR DRY-BULB TEMPERATURE (F)					
	79	78	77	76	75	under 75
	81	82	83	84	85	over 85
	Correction Factor					
.05	1.045	2.09	3.14	4.18	5.23	Use formula shown below.
.10	.99	1.98	2.97	3.96	4.95	
.20	.88	1.76	2.64	3.52	4.40	
.30	.77	1.54	2.31	3.08	3.85	
.35	.72	1.43	2.15	2.86	3.58	

$$\text{Correction Factor} = 1.10 \times (1 - \text{BF}) \times (\text{db} - 80).$$

Performance data (cont)



GROSS COOLING CAPACITIES (cont) 50BZN012 UNIT WITH 09BY012 CONDENSER

TEMP (F) AIR ENTERING CONDENSER (Edb)		AIR ENTERING EVAPORATOR — CFM/BF											
		3000 / 0.06				4000 / 0.08				5000 / 0.10			
		Air Entering Evaporator — Ewb (F)											
		72	67	62	57	72	67	62	57	72	67	62	57
65	TC	142.0	131.0	120.0	113.0	148.0	137.0	127.0	124.0	152.0	141.0	132.0	132.0
	SHC	70.4	87.1	103.0	113.0	77.9	99.6	120.0	124.0	85.1	111.0	132.0	132.0
	kW	9.03	8.85	8.69	8.58	9.48	9.28	9.12	9.07	9.88	9.69	9.54	9.54
75	TC	137.0	127.0	117.0	111.0	143.0	133.0	123.0	121.0	147.0	136.0	128.0	128.0
	SHC	68.7	85.4	102.0	111.0	76.3	97.8	117.0	121.0	83.5	109.0	128.0	128.0
	kW	9.93	9.74	9.57	9.46	10.4	10.2	10.0	9.96	10.8	10.6	10.4	10.4
85	TC	133.0	123.0	113.0	108.0	139.0	128.0	119.0	118.0	142.0	132.0	125.0	125.0
	SHC	67.1	83.7	99.7	108.0	74.8	96.1	115.0	118.0	81.9	107.0	125.0	125.0
	kW	10.8	10.6	10.4	10.3	11.3	11.1	10.9	10.9	11.7	11.5	11.3	11.3
95	TC	129.0	118.0	109.0	104.0	134.0	123.0	115.0	114.0	137.0	127.0	121.0	121.0
	SHC	65.4	81.9	97.7	104.0	72.9	94.2	113.0	114.0	79.9	105.0	121.0	121.0
	kW	11.8	11.6	11.4	11.3	12.3	12.4	11.8	11.8	12.6	12.4	12.3	12.3
105	TC	123.0	114.0	104.0	101.0	128.0	118.0	110.0	110.0	131.0	121.0	116.0	116.0
	SHC	63.4	79.9	95.5	101.0	71.1	92.1	110.0	110.0	78.0	103.0	116.0	116.0
	kW	12.8	12.6	12.4	12.3	13.3	13.1	12.9	12.9	13.7	13.5	13.3	13.3
115	TC	118.0	108.0	100.0	97.3	122.0	113.0	106.0	106.0	125.0	116.0	112.0	112.0
	SHC	61.5	77.8	93.3	97.3	68.9	89.9	106.0	106.0	76.1	101.0	112.0	112.0
	kW	14.0	13.7	13.5	13.4	14.5	14.2	14.0	14.0	14.9	14.6	14.5	14.5
125	TC	113.0	103.0	95.2	93.2	116.0	107.0	101.0	101.0	119.0	110.0	107.0	107.0
	SHC	59.5	75.6	90.7	93.2	66.9	87.5	101.0	101.0	73.9	98.3	107.0	107.0
	kW	15.3	14.9	14.7	14.6	15.7	15.4	15.3	15.3	16.1	15.8	15.8	15.8

Shaded area in table indicates nominal cfm values.

LEGEND

- BF — Bypass Factor
- Edb — Entering Dry Bulb
- Ewb — Entering Wet Bulb
- kW — Compressor Motor Power Input (kilowatts)
- SHC — Sensible Heating Capacity (1000 Btuh)
- TC — Total Capacity (1000 Btuh), Gross

NOTES:

1. Water gpm values are calculated using a 0.0005 fouling factor.
2. Direct interpolation is permissible. Do not extrapolate.
3. Gross capacities do *not* include deduction for indoor-fan motor heat.
4. Ratings for 50BZN units are based on 15 F of subcooling. For 0° F subcooling, reduce capacity by 7.5%.
5. All combinations use R-22. Unless otherwise designated, ratings are at optimum charge.
6. SHC is based on 80 F db temperature of air entering the coil. Below 80 F db, subtract (corr factor x cfm) from SHC. Above 80 F db, add (corr factor x cfm) to SHC.

The following formulas may be used:

$$ldb = edb - \frac{\text{sensible capacity (Btuh)}}{1.10 \times \text{cfm}}$$

$$lwb = \text{Wet-bulb temperature corresponding to enthalpy of air leaving evaporator coil } (h_{lwb})$$

$$h_{lwb} = h_{ewb} - \frac{\text{total capacity (Btuh)}}{4.5 \times \text{cfm}}$$

Where:

$$h_{ewb} = \text{Enthalpy of air entering evaporator coil.}$$

BYPASS FACTOR (BF)	ENTERING-AIR DRY-BULB TEMPERATURE (F)					
	79	78	77	76	75	under 75
	81	82	83	84	85	over 85
	Correction Factor					
.05	1.045	2.09	3.14	4.18	5.23	Use formula shown below.
.10	.99	1.98	2.97	3.96	4.95	
.20	.88	1.76	2.64	3.52	4.40	
.30	.77	1.54	2.31	3.08	3.85	
.35	.72	1.43	2.15	2.86	3.58	

$$\text{Correction Factor} = 1.10 \times (1 - \text{BF}) \times (\text{db} - 80).$$



GROSS COOLING CAPACITIES (cont)
50BZN014 UNIT WITH 09BY014 CONDENSER

TEMP (F) AIR ENTERING CONDENSER (Edb)		AIR ENTERING EVAPORATOR — CFM/BF											
		3750 / 0.08				5000 / 0.10				6250 / 0.12			
		Air Entering Evaporator — Ewb (F)											
		72	67	62	57	72	67	62	57	72	67	62	57
65	TC	153.0	143.0	132.0	127.0	160.0	150.0	139.0	138.0	163.0	153.0	146.0	145.0
	SHC	78.4	99.5	119.0	127.0	88.1	115.0	137.0	138.0	96.1	128.0	146.0	145.0
	KW	10.2	10.0	9.85	9.77	10.7	10.5	10.4	10.3	11.1	11.0	10.9	10.9
75	TC	148.0	137.0	128.0	123.0	154.0	143.0	134.0	134.0	157.0	147.0	141.0	140.0
	SHC	76.6	97.3	117.0	123.0	85.8	112.0	133.0	134.0	94.0	125.0	141.0	140.0
	KW	11.3	11.1	10.9	10.8	11.8	11.6	11.4	11.4	12.2	12.1	12.0	11.9
85	TC	143.0	132.0	123.0	120.0	148.0	137.0	129.0	129.0	150.0	140.0	136.0	135.0
	SHC	74.8	95.0	114.0	120.0	83.6	109.0	129.0	129.0	91.9	122.0	136.0	135.0
	KW	12.4	12.1	11.9	11.9	12.9	12.6	12.5	12.5	13.3	13.1	13.0	13.0
95	TC	137.0	126.0	118.0	115.0	141.0	131.0	124.0	124.0	144.0	134.0	130.0	130.0
	SHC	72.6	92.7	112.0	115.0	81.4	107.0	124.0	124.0	89.6	120.0	130.0	130.0
	KW	13.5	13.3	13.1	13.0	14.0	13.8	13.6	13.6	14.5	14.3	14.2	14.2
105	TC	130.0	120.0	113.0	111.0	134.0	124.0	119.0	119.0	136.0	127.0	125.0	125.0
	SHC	70.3	90.3	109.0	111.0	79.0	104.0	119.0	119.0	87.2	117.0	125.0	125.0
	KW	14.8	14.5	14.3	14.2	15.3	15.0	14.9	14.9	15.8	15.5	15.5	15.4
115	TC	123.0	114.0	107.0	106.0	127.0	118.0	114.0	113.0	129.0	120.0	119.0	119.0
	SHC	67.8	87.8	106.0	106.0	76.5	102.0	114.0	113.0	84.7	113.0	119.0	119.0
	KW	16.1	15.8	15.6	15.6	16.6	16.3	16.2	16.2	17.1	16.8	16.8	16.8
125	TC	116.0	108.0	101.0	101.0	119.0	111.0	108.0	108.0	121.0	114.0	113.0	113.0
	SHC	65.3	85.2	101.0	101.0	74.0	98.6	108.0	108.0	82.1	110.0	113.0	113.0
	KW	17.5	17.2	16.9	16.9	18.1	17.7	17.6	17.6	18.5	18.2	18.2	18.2

Shaded area in table indicates nominal cfm values.

LEGEND

- BF** — Bypass Factor
- Edb** — Entering Dry Bulb
- Ewb** — Entering Wet Bulb
- kW** — Compressor Motor Power Input (kilowatts)
- SHC** — Sensible Heating Capacity (1000 Btuh)
- TC** — Total Capacity (1000 Btuh), Gross

NOTES:

1. Water gpm values are calculated using a 0.0005 fouling factor.
2. Direct interpolation is permissible. Do not extrapolate.
3. Gross capacities do *not* include deduction for indoor-fan motor heat.
4. Ratings for 50BZN units are based on 15 F of subcooling. For 0° F subcooling, reduce capacity by 7.5%.
5. All combinations use R-22. Unless otherwise designated, ratings are at optimum charge.
6. SHC is based on 80 F db temperature of air entering the coil. Below 80 F db, subtract (corr factor x cfm) from SHC. Above 80 F db, add (corr factor x cfm) to SHC.

The following formulas may be used:

$$ldb = edb - \frac{\text{sensible capacity (Btuh)}}{1.10 \times \text{cfm}}$$

$$lwb = \text{Wet-bulb temperature corresponding to enthalpy of air leaving evaporator coil } (h_{lwb})$$

$$h_{lwb} = h_{ewb} - \frac{\text{total capacity (Btuh)}}{4.5 \times \text{cfm}}$$

Where:

$$h_{ewb} = \text{Enthalpy of air entering evaporator coil.}$$

BYPASS FACTOR (BF)	ENTERING-AIR DRY-BULB TEMPERATURE (F)					
	79	78	77	76	75	under 75
	81	82	83	84	85	over 85
	Correction Factor					
.05	1.045	2.09	3.14	4.18	5.23	Use formula shown below.
.10	.99	1.98	2.97	3.96	4.95	
.20	.88	1.76	2.64	3.52	4.40	
.30	.77	1.54	2.31	3.08	3.85	
.35	.72	1.43	2.15	2.86	3.58	

$$\text{Correction Factor} = 1.10 \times (1 - \text{BF}) \times (\text{db} - 80).$$

Performance data (cont)



GROSS COOLING CAPACITIES (cont) 50BZN016 UNIT WITH 09BY016 CONDENSER

TEMP (F) AIR ENTERING CONDENSER (Edb)		AIR ENTERING EVAPORATOR — CFM/BF											
		4500 / 0.09				6000 / 0.12				7500 / 0.14			
		Air Entering Evaporator — Ewb (F)											
		72	67	62	57	72	67	62	57	72	67	62	57
65	TC	185.0	171.0	158.0	152.0	193.0	178.0	166.0	164.0	197.0	183.0	174.0	174.0
	SHC	94.4	118.0	141.0	152.0	105.0	136.0	162.0	164.0	115.0	151.0	174.0	174.0
	kW	11.6	11.3	11.1	11.0	12.2	11.9	11.7	11.6	12.8	12.4	12.3	12.3
75	TC	179.0	166.0	153.0	148.0	186.0	172.0	161.0	160.0	191.0	177.0	169.0	169.0
	SHC	92.3	116.0	139.0	148.0	103.0	133.0	159.0	160.0	113.0	149.0	169.0	169.0
	kW	12.8	12.5	12.2	12.1	13.4	13.1	12.9	12.8	14.0	13.7	13.5	13.5
85	TC	174.0	160.0	148.0	144.0	180.0	167.0	156.0	156.0	184.0	171.0	164.0	164.0
	SHC	90.1	114.0	136.0	144.0	101.0	131.0	155.0	156.0	110.0	146.0	164.0	164.0
	kW	14.1	13.7	13.4	13.3	14.7	14.3	14.0	14.0	15.3	14.9	14.7	14.7
95	TC	168.0	155.0	143.0	140.0	174.0	161.0	151.0	151.0	177.0	165.0	159.0	159.0
	SHC	87.9	112.0	134.0	140.0	98.4	129.0	151.0	151.0	108.0	144.0	159.0	159.0
	kW	15.4	15.0	14.6	14.5	16.0	15.6	15.3	15.3	16.6	16.2	16.0	16.0
105	TC	161.0	149.0	138.0	135.0	167.0	154.0	146.0	146.0	170.0	158.0	153.0	153.0
	SHC	85.5	109.0	131.0	135.0	96.0	126.0	146.0	146.0	106.0	141.0	153.0	153.0
	kW	16.8	16.4	16.0	15.9	17.4	17.0	16.7	16.7	18.0	17.5	17.4	17.4
115	TC	154.0	142.0	132.0	131.0	159.0	147.0	141.0	141.0	162.0	151.0	148.0	147.0
	SHC	83.0	107.0	128.0	131.0	93.4	123.0	141.0	141.0	103.0	137.0	148.0	147.0
	kW	18.2	17.8	17.4	17.3	18.9	18.4	18.2	18.2	19.5	19.0	18.9	18.9
125	TC	147.0	136.0	127.0	126.0	151.0	140.0	134.0	134.0	154.0	144.0	141.0	141.0
	SHC	80.4	104.0	125.0	126.0	90.7	120.0	134.0	134.0	100.0	134.0	141.0	141.0
	kW	19.8	19.3	19.0	18.9	20.4	20.0	19.7	19.7	21.0	20.6	20.4	20.4

Shaded area in table indicates nominal cfm values.

LEGEND

- BF — Bypass Factor
- Edb — Entering Dry Bulb
- Ewb — Entering Wet Bulb
- kW — Compressor Motor Power Input (kilowatts)
- SHC — Sensible Heating Capacity (1000 Btuh)
- TC — Total Capacity (1000 Btuh), Gross

NOTES:

1. Water gpm values are calculated using a 0.0005 fouling factor.
2. Direct interpolation is permissible. Do not extrapolate.
3. Gross capacities do *not* include deduction for indoor-fan motor heat.
4. Ratings for 50BZN units are based on 15 F of subcooling. For 0° F subcooling, reduce capacity by 7.5%.
5. All combinations use R-22. Unless otherwise designated, ratings are at optimum charge.
6. SHC is based on 80 F db temperature of air entering the coil. Below 80 F db, subtract (corr factor x cfm) from SHC. Above 80 F db, add (corr factor x cfm) to SHC.

The following formulas may be used:

$$ldb = edb - \frac{\text{sensible capacity (Btuh)}}{1.10 \times \text{cfm}}$$

$$lwb = \text{Wet-bulb temperature corresponding to enthalpy of air leaving evaporator coil } (h_{lwb})$$

$$h_{lwb} = h_{ewb} - \frac{\text{total capacity (Btuh)}}{4.5 \times \text{cfm}}$$

Where:

$$h_{ewb} = \text{Enthalpy of air entering evaporator coil.}$$

BYPASS FACTOR (BF)	ENTERING-AIR DRY-BULB TEMPERATURE (F)					
	79	78	77	76	75	under 75
	81	82	83	84	85	over 85
	Correction Factor					
.05	1.045	2.09	3.14	4.18	5.23	Use formula shown below.
.10	.99	1.98	2.97	3.96	4.95	
.20	.88	1.76	2.64	3.52	4.40	
.30	.77	1.54	2.31	3.08	3.85	
.35	.72	1.43	2.15	2.86	3.58	

$$\text{Correction Factor} = 1.10 \times (1 - \text{BF}) \times (\text{db} - 80).$$



GROSS COOLING CAPACITIES (cont)
50BZN016 UNIT WITH 09DE016 CONDENSER

TEMP (F) AIR ENTERING CONDENSER (Edb)		AIR ENTERING EVAPORATOR — CFM/BF											
		4500 / 0.09				6000 / 0.12				7500 / 0.14			
		Air Entering Evaporator — Ewb (F)											
		72	67	62	57	72	67	62	57	72	67	62	57
65	TC	185.0	171.0	157.0	151.0	192.0	177.0	165.0	164.0	196.0	182.0	173.0	173.0
	SHC	94.1	118.0	141.0	151.0	105.0	135.0	162.0	164.0	114.0	151.0	173.0	173.0
	KW	12.2	11.9	11.6	11.4	12.8	12.5	12.2	12.2	13.4	13.1	12.8	12.8
75	TC	179.0	165.0	152.0	147.0	185.0	171.0	160.0	159.0	189.0	176.0	168.0	168.0
	SHC	91.9	116.0	139.0	147.0	102.0	133.0	158.0	159.0	112.0	148.0	168.0	168.0
	KW	13.5	13.1	12.8	12.6	14.1	13.7	13.4	13.4	14.6	14.3	14.1	14.1
85	TC	172.0	159.0	147.0	143.0	178.0	165.0	155.0	155.0	182.0	169.0	162.0	163.0
	SHC	89.7	114.0	136.0	143.0	100.0	130.0	154.0	155.0	110.0	146.0	162.0	163.0
	KW	14.7	14.3	13.9	13.8	15.3	14.9	14.6	14.6	15.9	15.5	15.3	15.3
95	TC	166.0	153.0	142.0	139.0	172.0	159.0	150.0	150.0	175.0	163.0	157.0	158.0
	SHC	87.3	111.0	133.0	139.0	97.7	128.0	150.0	150.0	107.0	143.0	157.0	158.0
	KW	16.0	15.6	15.2	15.1	16.7	16.2	15.9	15.9	17.2	16.8	16.6	16.6
105	TC	159.0	147.0	136.0	134.0	165.0	152.0	144.0	144.0	168.0	156.0	151.0	152.0
	SHC	84.9	109.0	130.0	134.0	95.2	125.0	144.0	144.0	105.0	140.0	151.0	152.0
	KW	17.4	16.9	16.5	16.4	18.1	17.6	17.3	17.3	18.6	18.2	18.0	18.0
115	TC	153.0	141.0	131.0	129.0	157.0	146.0	139.0	139.0	160.0	149.0	145.0	146.0
	SHC	82.5	106.0	127.0	129.0	92.7	122.0	139.0	139.0	102.0	137.0	145.0	146.0
	KW	18.9	18.4	17.9	17.9	19.6	19.0	18.7	18.8	20.1	19.6	19.5	19.5
125	TC	145.0	134.0	125.0	124.0	149.0	138.0	133.0	133.0	151.0	142.0	139.0	139.0
	SHC	79.8	103.0	123.0	124.0	90.1	119.0	133.0	133.0	99.2	133.0	139.0	139.0
	KW	20.5	19.9	19.5	19.4	21.1	20.6	20.3	20.3	21.7	21.2	21.1	21.1

Shaded area in table indicates nominal cfm values.

LEGEND

- BF** — Bypass Factor
- Edb** — Entering Dry Bulb
- Ewb** — Entering Wet Bulb
- kW** — Compressor Motor Power Input (kilowatts)
- SHC** — Sensible Heating Capacity (1000 Btuh)
- TC** — Total Capacity (1000 Btuh), Gross

NOTES:

1. Water gpm values are calculated using a 0.0005 fouling factor.
2. Direct interpolation is permissible. Do not extrapolate.
3. Gross capacities do *not* include deduction for indoor-fan motor heat.
4. Ratings for 50BZN units are based on 15 F of subcooling. For 0° F subcooling, reduce capacity by 7.5%.
5. All combinations use R-22. Unless otherwise designated, ratings are at optimum charge.
6. SHC is based on 80 F db temperature of air entering the coil. Below 80 F db, subtract (corr factor x cfm) from SHC. Above 80 F db, add (corr factor x cfm) to SHC.

The following formulas may be used:

$$ldb = edb - \frac{\text{sensible capacity (Btuh)}}{1.10 \times \text{cfm}}$$

$$lwb = \text{Wet-bulb temperature corresponding to enthalpy of air leaving evaporator coil (} h_{lwb} \text{)}$$

$$h_{lwb} = h_{ewb} - \frac{\text{total capacity (Btuh)}}{4.5 \times \text{cfm}}$$

Where:

h_{ewb} = Enthalpy of air entering evaporator coil.

BYPASS FACTOR (BF)	ENTERING-AIR DRY-BULB TEMPERATURE (F)					
	79	78	77	76	75	under 75
	81	82	83	84	85	over 85
	Correction Factor					
.05	1.045	2.09	3.14	4.18	5.23	Use formula shown below.
.10	.99	1.98	2.97	3.96	4.95	
.20	.88	1.76	2.64	3.52	4.40	
.30	.77	1.54	2.31	3.08	3.85	
.35	.72	1.43	2.15	2.86	3.58	

$$\text{Correction Factor} = 1.10 \times (1 - \text{BF}) \times (\text{db} - 80).$$

Performance data (cont)



ACCESSORY HEATING COIL RATINGS

UNIT 50BRN,BZN	AIR CFM	NONFREEZE STEAM*		HOT WATER†			
		TC	LAT	TC	LAT	Gpm	PD
006	1,500	116	130	101	120	10	3.7
	2,000	134	120	117	112	12	4.6
	2,500	147	115	131	107	13	5.8
008	2,250	97	100	172	131	17	3.5
	3,000	118	96	211	125	21	4.6
	3,750	132	93	239	119	24	5.5
012	3,000	118	96	211	125	21	4.6
	4,000	137	92	247	117	25	5.8
	5,000	153	88	276	111	28	6.8
014	3,750	164	99	243	120	24	5.0
	5,000	177	92	292	114	29	6.0
	6,250	231	91	323	107	32	7.1
016	4,500	209	102	307	122	30	5.1
	6,000	234	95	363	115	36	6.2
	7,500	256	91	396	108	39	7.4
024*	6,000	209	92	410	126	41	2.4
	8,000	246	88	500	118	50	3.5
	10,000	272	85	580	114	58	3.9

LEGEND

- LAT** — Leaving-Air Temperature (F)
PD — Pressure Drop (ft of water)
TC — Total Capacity (1000 Btuh)

*Nonfreeze steam coil — 1-row — available on all 50BRN,BZN sizes. Nonfreeze coil ratings based on 2 psig steam, 60 F entering air.

†Hot water coil — All hot water coils are 2-row. The 2-row hot water coil ratings based on 200 F entering water temperature, 20 F water temperature drop, 60 F entering air.

**50BRN only.

NOTES:

- Maximum allowable leaving air temperature 140 F.
- Maximum operating limit for heating coils is 200 psig or 400 F.**
- To obtain capacities other than those given above, multiply the Btuh value from the Accessory Heating Coil Ratings table by the proper value from the Heating Capacity Factors table.
- Formulas:

$$\text{Final temp (F)} = \text{edb (entering dry bulb) (F)} + \frac{\text{Btuh}}{1.10 \times \text{cfm}}$$

$$\text{Gpm} = \frac{\text{Btuh}}{500 \times \text{water temp drop (F)}}$$

- Reduced airflow (dirty filters, loose or broken fan belt, etc.) over coil during cooling cycle may result in freeze-up of nearby heating coil. Since units normally require a low-pressure switch cutout setting at about 5 F, use of a freeze-up thermostat is recommended if heating coil is not drained or filled with an antifreeze solution.
- Field-supplied thermostat and control valve are required when using accessory heating coils.

STATIC PRESSURE LOSS OF ACCESSORIES (in. wg)

UNIT 50BRN,BZN	AIR QTY (Cfm)	HEATING COILS		ACCESSORIES
		Nonfreeze Steam	Hot Water	Discharge Plenum
006	1,500	.04	.04	.05
	2,000	.05	.05	.10
	2,500	.08	.08	.15
008	2,250	.02	.04	.13
	3,000	.04	.08	.21
	3,750	.06	.12	.26
012	3,000	.04	.08	.21
	4,000	.07	.14	.29
	5,000	.10	.21	.35
014	3,750	.04	.08	.22
	5,000	.06	.14	.30
	6,250	.08	.21	.36
016	4,500	.05	.10	.23
	6,000	.07	.16	.31
	7,500	.09	.23	.35
024*	6,000	.01	.05	.25
	8,000	.02	.08	.33
	10,000	.03	.11	.37

*50BRN only.

HEATING CAPACITY FACTORS

STEAM COIL

Steam Pressure (Psig)	Entering Air Temperature (F)				
	40	50	60	70	80
0	1.11	1.03	.96	.89	.82
2	1.14	1.07	1.00	.93	.86
5	1.19	1.11	1.05	.98	.91
10	1.25	1.18	1.11	1.04	.97

HOT WATER COIL

Water Temp (F) Drop	Entering Water Temp (F)	Entering Air Temperature (F)				
		40	50	60	70	80
10	180	1.06	.98	.90	.83	.75
	200	1.22	1.15	1.07	1.00	.92
	220	1.39	1.32	1.24	1.17	1.09
20	180	.98	.91	.83	.75	.68
	200	1.15	1.08	1.00	.93	.85
	220	1.32	1.25	1.17	1.10	1.02
30	180	.91	.83	.76	.68	.60
	200	1.08	1.00	.93	.85	.78
	220	1.25	1.18	1.10	1.03	.95



FAN PERFORMANCE

50BRN,BZN006 UNIT

AIRFLOW (cfm)	Available External Static Pressure (in. wg)													
	0.2		0.4		0.6		0.8		1.0		1.2		1.4	
	Rpm	Bhp	Rpm	Bhp	Rpm	Bhp	Rpm	Bhp	Rpm	Bhp	Rpm	Bhp	Rpm	Bhp
1500	<i>760</i>	<i>0.21</i>	<i>899</i>	<i>0.28</i>	<i>1038</i>	<i>0.37</i>	<i>1173</i>	<i>0.46</i>	<i>1297</i>	<i>0.54</i>	<i>1412</i>	<i>0.66</i>	<i>1504</i>	<i>0.79</i>
1750	<i>833</i>	<i>0.31</i>	<i>950</i>	<i>0.38</i>	<i>1072</i>	<i>0.47</i>	<i>1191</i>	<i>0.57</i>	<i>1310</i>	<i>0.67</i>	<i>1422</i>	<i>0.77</i>	<i>1526</i>	<i>0.88</i>
2000	<i>912</i>	<i>0.43</i>	<i>1018</i>	<i>0.50</i>	<i>1123</i>	<i>0.59</i>	<i>1224</i>	<i>0.70</i>	<i>1328</i>	<i>0.81</i>	<i>1434</i>	<i>0.93</i>	<i>1536</i>	<i>1.05</i>
2250	<i>994</i>	<i>0.58</i>	<i>1085</i>	<i>0.67</i>	<i>1180</i>	<i>0.76</i>	<i>1275</i>	<i>0.86</i>	<i>1364</i>	<i>0.98</i>	<i>1455</i>	<i>1.10</i>	<i>1550</i>	<i>1.24</i>
2500	<i>1078</i>	<i>0.76</i>	<i>1159</i>	<i>0.87</i>	<i>1244</i>	<i>0.95</i>	<i>1326</i>	<i>1.06</i>	<i>1414</i>	<i>1.17</i>	<i>1495</i>	<i>1.30</i>	<i>1575</i>	<i>1.44</i>

LEGEND

Bhp — Brake Horsepower to Supply Fan

NOTE: *Italics* indicates field-supplied drive is required.

50BRN,BZN008 UNIT

AIRFLOW (cfm)	Available External Static Pressure (in. wg)													
	0.2		0.4		0.6		0.8		1.0		1.2		1.4	
	Rpm	Bhp	Rpm	Bhp	Rpm	Bhp	Rpm	Bhp	Rpm	Bhp	Rpm	Bhp	Rpm	Bhp
2250	<i>720</i>	<i>0.37</i>	<i>823</i>	<i>0.46</i>	<i>916</i>	<i>0.56</i>	<i>1018</i>	<i>0.68</i>	—	—	—	—	—	—
2500	<i>775</i>	<i>0.48</i>	<i>866</i>	<i>0.58</i>	<i>955</i>	<i>0.69</i>	<i>1038</i>	<i>0.80</i>	<i>1132</i>	<i>0.93</i>	—	—	—	—
2750	<i>831</i>	<i>0.62</i>	<i>912</i>	<i>0.73</i>	<i>995</i>	<i>0.83</i>	<i>1073</i>	<i>0.96</i>	<i>1151</i>	<i>1.08</i>	<i>1236</i>	<i>1.22</i>	<i>1329</i>	<i>1.38</i>
3000	<i>888</i>	<i>0.78</i>	<i>961</i>	<i>0.89</i>	<i>1039</i>	<i>1.00</i>	<i>1117</i>	<i>1.14</i>	<i>1183</i>	<i>1.26</i>	<i>1254</i>	<i>1.40</i>	<i>1332</i>	<i>1.56</i>
3250	<i>945</i>	<i>0.96</i>	<i>1014</i>	<i>1.08</i>	<i>1083</i>	<i>1.21</i>	<i>1151</i>	<i>1.33</i>	<i>1225</i>	<i>1.48</i>	<i>1286</i>	<i>1.62</i>	<i>1352</i>	<i>1.77</i>
3500	<i>1003</i>	<i>1.17</i>	<i>1068</i>	<i>1.29</i>	<i>1130</i>	<i>1.43</i>	<i>1197</i>	<i>1.57</i>	<i>1260</i>	<i>1.70</i>	<i>1327</i>	<i>1.87</i>	—	—
3750	<i>1061</i>	<i>1.41</i>	<i>1123</i>	<i>1.54</i>	<i>1181</i>	<i>1.68</i>	<i>1241</i>	<i>1.84</i>	<i>1303</i>	<i>1.97</i>	—	—	—	—

LEGEND

Bhp — Brake Horsepower to Supply Fan

NOTES:

1. *Italics* indicates field-supplied drive is required.
2. Do not operate in area.

50BRN,BZN012 UNIT

AIRFLOW (cfm)	Available External Static Pressure (in. wg)													
	0.2		0.4		0.6		0.8		1.0		1.2		1.4	
	Rpm	Bhp	Rpm	Bhp	Rpm	Bhp	Rpm	Bhp	Rpm	Bhp	Rpm	Bhp	Rpm	Bhp
3000	<i>659</i>	<i>0.52</i>	<i>744</i>	<i>0.64</i>	<i>835</i>	<i>0.78</i>	<i>930</i>	<i>0.95</i>	<i>1026</i>	<i>1.16</i>	—	—	—	—
3250	<i>697</i>	<i>0.64</i>	<i>775</i>	<i>0.77</i>	<i>857</i>	<i>0.91</i>	<i>943</i>	<i>1.07</i>	<i>1031</i>	<i>1.27</i>	<i>1120</i>	<i>1.49</i>	—	—
3500	<i>735</i>	<i>0.78</i>	<i>808</i>	<i>0.91</i>	<i>883</i>	<i>1.05</i>	<i>961</i>	<i>1.21</i>	<i>1041</i>	<i>1.40</i>	<i>1123</i>	<i>1.62</i>	<i>1207</i>	<i>1.86</i>
3750	<i>776</i>	<i>0.93</i>	<i>843</i>	<i>1.07</i>	<i>911</i>	<i>1.22</i>	<i>983</i>	<i>1.38</i>	<i>1056</i>	<i>1.56</i>	<i>1132</i>	<i>1.77</i>	<i>1209</i>	<i>2.01</i>
4000	<i>817</i>	<i>1.10</i>	<i>879</i>	<i>1.24</i>	<i>942</i>	<i>1.41</i>	<i>1008</i>	<i>1.57</i>	<i>1076</i>	<i>1.75</i>	<i>1146</i>	<i>1.95</i>	<i>1217</i>	<i>2.18</i>
4250	<i>858</i>	<i>1.30</i>	<i>915</i>	<i>1.45</i>	<i>975</i>	<i>1.61</i>	<i>1036</i>	<i>1.78</i>	<i>1098</i>	<i>1.96</i>	<i>1163</i>	<i>2.16</i>	<i>1229</i>	<i>2.38</i>
4500	<i>898</i>	<i>1.51</i>	<i>953</i>	<i>1.67</i>	<i>1010</i>	<i>1.83</i>	<i>1066</i>	<i>2.02</i>	<i>1124</i>	<i>2.20</i>	<i>1184</i>	<i>2.39</i>	<i>1245</i>	<i>2.61</i>
4750	<i>939</i>	<i>1.76</i>	<i>991</i>	<i>1.92</i>	<i>1045</i>	<i>2.09</i>	<i>1098</i>	<i>2.28</i>	<i>1152</i>	<i>2.47</i>	<i>1208</i>	<i>2.66</i>	<i>1265</i>	<i>2.87</i>
5000	<i>980</i>	<i>2.02</i>	<i>1030</i>	<i>2.19</i>	<i>1080</i>	<i>2.37</i>	<i>1131</i>	<i>2.56</i>	<i>1182</i>	<i>2.76</i>	<i>1234</i>	<i>2.96</i>	—	—

LEGEND

Bhp — Brake Horsepower to Supply Fan

NOTES:

1. *Italics* indicates field-supplied drive is required.
2. Do not operate in area.

Performance data (cont)



FAN PERFORMANCE (cont)

50BRN,BZN014 UNIT

AIRFLOW (cfm)	Available External Static Pressure (in. wg)													
	0.2		0.4		0.6		0.8		1.0		1.2		1.4	
	Rpm	Bhp	Rpm	Bhp	Rpm	Bhp	Rpm	Bhp	Rpm	Bhp	Rpm	Bhp	Rpm	Bhp
3750	581	0.66	658	0.82	733	0.98	806	1.16	882	1.37	—	—	—	—
4000	608	0.78	679	0.94	749	1.11	819	1.29	889	1.50	961	1.73	—	—
4250	635	0.91	701	1.07	769	1.25	835	1.44	899	1.64	966	1.87	1034	2.12
4500	663	1.05	724	1.22	789	1.41	851	1.60	912	1.81	974	2.03	1038	2.28
4800	696	1.24	753	1.42	814	1.62	873	1.82	932	2.03	988	2.25	1046	2.50
5250	746	1.57	799	1.77	852	1.97	908	2.19	962	2.41	1016	2.64	1067	2.88
5500	775	1.78	825	1.98	875	2.19	929	2.42	981	2.65	1031	2.88	1082	3.13
5750	804	2.01	852	2.22	899	2.43	949	2.66	1000	2.90	1049	3.15	1098	3.40
6000	833	2.26	878	2.47	924	2.69	971	2.92	1020	3.17	1068	3.43	1114	3.68

LEGEND

Bhp — Brake Horsepower to Supply Fan

NOTES:

1. *Italics* indicates field-supplied drive is required.
2. Do not operate in area.

50BRN,BZN016 UNIT

AIRFLOW (cfm)	Available External Static Pressure (in. wg)													
	0.2		0.4		0.6		0.8		1.0		1.2		1.4	
	Rpm	Bhp	Rpm	Bhp	Rpm	Bhp	Rpm	Bhp	Rpm	Bhp	Rpm	Bhp	Rpm	Bhp
4500	867	1.02	962	1.23	1072	1.48	1184	1.75	1286	2.04	1381	2.35	1464	2.66
5000	937	1.33	1018	1.55	1109	1.80	1211	2.08	1311	2.38	1404	2.70	1492	3.04
5500	1000	1.68	1077	1.93	1155	2.18	1241	2.46	1334	2.78	1426	3.11	—	—
6000	1062	2.10	1140	2.36	1207	2.62	1281	2.91	1361	3.22	1446	3.57	—	—
6500	1129	2.57	1202	2.86	1264	3.14	1328	3.43	1397	3.74	1471	4.09	—	—
7000	1193	3.13	1257	3.39	1324	3.72	1381	4.02	1441	4.34	—	—	—	—
7500	1257	3.76	1315	4.04	1382	4.36	1437	4.69	—	—	—	—	—	—

LEGEND

Bhp — Brake Horsepower to Supply Fan

NOTES:

1. *Italics* indicates field-supplied drive is required.
2. Do not operate in area.

50BRN024 UNIT

AIRFLOW (cfm)	Available External Static Pressure (in. wg)													
	0.2		0.4		0.6		0.8		1.0		1.2		1.4	
	Rpm	Bhp	Rpm	Bhp	Rpm	Bhp	Rpm	Bhp	Rpm	Bhp	Rpm	Bhp	Rpm	Bhp
6,000	749	1.30	840	1.58	935	1.92	1032	2.33	1133	2.77	—	—	—	—
6,500	791	1.59	874	1.87	960	2.21	1048	2.62	1139	3.07	—	—	—	—
7,000	833	1.92	909	2.20	988	2.54	1069	2.94	1151	3.40	1236	3.89	—	—
7,500	875	2.28	945	2.58	1017	2.92	1092	3.31	1168	3.76	1244	4.26	1325	4.79
8,000	917	2.68	981	3.00	1048	3.34	1117	3.73	1188	4.17	1259	4.65	1331	5.20
8,500	959	3.12	1018	3.47	1080	3.81	1145	4.20	1210	4.63	1277	5.11	1344	5.63
9,000	1000	3.61	1056	3.98	1114	4.34	1174	4.72	1235	5.15	1297	5.62	1360	6.13
9,500	1042	4.15	1094	4.53	1149	4.91	1204	5.29	1261	5.72	1320	6.19	1379	6.69
10,000	1082	4.75	1133	5.13	1184	5.54	1236	5.94	1290	6.35	1344	6.82	1400	7.31

LEGEND

Bhp — Brake Horsepower to Supply Fan

NOTES:

1. *Italics* indicates field-supplied drive is required.
2. Do not operate in area.

Electrical data



50BRN UNIT ELECTRICAL DATA

50BRN UNIT SIZE	V-Ph-Hz	COMPRESSOR NO. 1		COMPRESSOR NO. 2		COMPRESSOR NO. 3		OUTDOOR FAN MOTOR		INDOOR FAN MOTOR		POWER SUPPLY*	
		RLA	LRA	RLA	LRA	RLA	LRA	Hp	FLA	Hp	FLA	MCA	MOCP†
006	208/230-3-60	16.0	125.0	—	—	—	—	—	—	1.5	4.4	24.4	30
	460-3-60	7.2	56.5	—	—	—	—	—	—	1.5	2.0	11.0	15
	575-3-60	5.8	45.2	—	—	—	—	—	—	1.5	1.6	8.8	10
008	208/230-3-60	18.9	146.0	—	—	—	—	—	—	2.0	5.8	29.4	35
	460-3-60	8.5	66.0	—	—	—	—	—	—	2.0	2.6	13.3	20
	575-3-60	6.8	52.8	—	—	—	—	—	—	2.0	2.1	10.6	15
012	208/230-3-60	16.0	125.0	16.0	125.0	—	—	—	—	3.0	8.6	44.6	50
	460-3-60	7.2	56.5	7.2	56.5	—	—	—	—	3.0	3.9	20.2	25
	575-3-60	5.8	45.2	5.8	45.2	—	—	—	—	3.0	3.1	16.1	20
014	208/230-3-60	16.0	125.0	18.9	146	—	—	—	—	5.0	14.2	53.8	60
	460-3-60	7.2	56.5	8.5	66.0	—	—	—	—	5.0	6.4	24.3	30
	575-3-60	5.8	45.2	6.8	52.8	—	—	—	—	5.0	5.1	19.4	25
016	208/230-3-60	18.9	146.0	18.9	146.0	—	—	—	—	5.0	14.2	56.7	70
	460-3-60	8.5	66.0	8.5	66.0	—	—	—	—	5.0	6.4	25.6	30
	575-3-60	6.8	52.8	6.8	52.8	—	—	—	—	5.0	5.1	20.5	25
024	208/230-3-60	18.9	146.0	18.9	146.0	18.9	146.0	—	—	7.5	20.5	82.3	100
	460-3-60	8.5	66.0	8.5	66.0	8.5	66.0	—	—	7.5	9.3	37.3	45
	575-3-60	6.8	52.8	6.8	52.8	6.8	52.8	—	—	7.5	7.4	29.8	35

50BZN UNIT ELECTRICAL DATA

50BZN UNIT SIZE	V-Ph-Hz	COMPRESSOR NO. 1		COMPRESSOR NO. 2		COMPRESSOR NO. 3		OUTDOOR FAN MOTOR		INDOOR FAN MOTOR		POWER SUPPLY*	
		RLA	LRA	RLA	LRA	RLA	LRA	Hp	FLA	Hp	FLA	MCA	MOCP†
006	208/230-3-60	16.0	125.0	—	—	—	—	2.0	5.8	1.5	4.4	30.2	40
	460-3-60	7.2	56.5	—	—	—	—	2.0	2.6	1.5	2.0	13.6	20
	575-3-60	5.8	45.2	—	—	—	—	2.0	2.1	1.5	1.6	10.9	15
008	208/230-3-60	18.9	146.0	—	—	—	—	3.0	8.6	2.0	5.8	38.0	45
	460-3-60	8.5	66.0	—	—	—	—	3.0	3.9	2.0	2.6	17.2	25
	575-3-60	6.8	52.8	—	—	—	—	3.0	3.1	2.0	2.1	13.7	20
012	208/230-3-60	16.0	125.0	16.0	125.0	—	—	5.0	14.2	3.0	8.6	58.8	70
	460-3-60	7.2	56.5	7.2	56.5	—	—	5.0	6.4	3.0	3.9	26.6	35
	575-3-60	5.8	45.2	5.8	45.2	—	—	5.0	5.1	3.0	3.1	21.2	25
014	208/230-3-60	16.0	125.0	18.9	146.0	—	—	5.0	14.2	5.0	14.2	68.0	80
	460-3-60	7.2	56.5	8.5	66.0	—	—	5.0	6.4	5.0	6.4	30.7	40
	575-3-60	5.8	45.2	6.8	52.8	—	—	5.0	5.1	5.0	5.1	24.5	30
016	208/230-3-60	18.9	146.0	18.9	146.0	—	—	5.0	14.2	5.0	14.2	70.9	80
	460-3-60	8.5	66.0	8.5	66.0	—	—	5.0	6.4	5.0	6.4	32.0	40
	575-3-60	6.8	52.8	6.8	52.8	—	—	5.0	5.1	5.0	5.1	25.6	30

LEGEND

FLA	— Full Load Amps
LRA	— Locked Rotor Amps
MCA	— Minimum Circuit Amps
MOCP	— Maximum Overcurrent Protective Device (see Note 1)
NEC	— National Electrical Code
RLA	— Rated Load Amps

*Minimum circuit amps and MOCP amps values per NEC (see Note 1).
 †Maximum overcurrent protective device for 208/230-v units and 460-v units is fuse only; 575-v units may be fuse or circuit breaker (see Note 1).

NOTES:

1. In compliance with NEC requirements for multimotor and combination load equipment (NEC Articles 430 and 440), the overcurrent protective device for the unit shall be either circuit breaker (where available) or fuse.
2. Wire sizing amps are a sum of 125% of the largest RLA plus 100% of all other loads.
3. Motors are protected against primary single phasing condition.
4. Indoor fan motors are 3-phase motors of same voltage as unit.
5. Three-phase voltage imbalance must not exceed 2%.

Electrical data (cont)



09BY CONDENSER ELECTRICAL DATA

09BY UNIT SIZE	V-Ph-Hz	OUTDOOR FAN MOTOR		INDOOR FAN MOTOR		POWER SUPPLY*	
		Hp	FLA	Hp	FLA	MCA	MOCP†
006	208/230-3-60	2.0	5.8	—	—	7.3	10
	460-3-60		2.6	—	—	3.3	10
	575-3-60		2.1	—	—	2.6	10
008	208/230-3-60	3.0	8.6	—	—	10.8	15
	460-3-60		3.9	—	—	4.9	10
	575-3-60		3.1	—	—	3.9	10
012	208/230-3-60	5.0	14.2	—	—	17.8	25
	460-3-60		6.4	—	—	8.0	10
	575-3-60		5.1	—	—	6.4	10
014	208/230-3-60	5.0	14.2	—	—	17.8	25
	460-3-60		6.4	—	—	8.0	10
	575-3-60		5.1	—	—	6.4	10
016	208/230-3-60	5.0	14.2	—	—	17.8	25
	460-3-60		6.4	—	—	8.0	10
	575-3-60		5.1	—	—	6.4	10

LEGEND

FLA — Full Load Amps
MCA — Minimum Circuit Amps
MOCP — Maximum Overcurrent Protective Device (see Note)

*Minimum circuit amps and MOCP amps values per NEC (see Note).
 †Maximum overcurrent protective device for 208/230-v units and 460-v units is fuse only; 575-v units may be fuse or circuit breaker.

NOTE: In compliance with NEC requirements for multimotor and combination load equipment (NEC Articles 430 and 440), the overcurrent protective device for the unit shall be either circuit breaker (where available) or fuse.

Typical wiring schematics



50BRN,BZN006,008 UNITS

3~208/230/460/575V

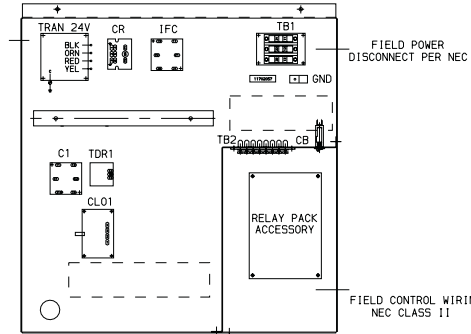
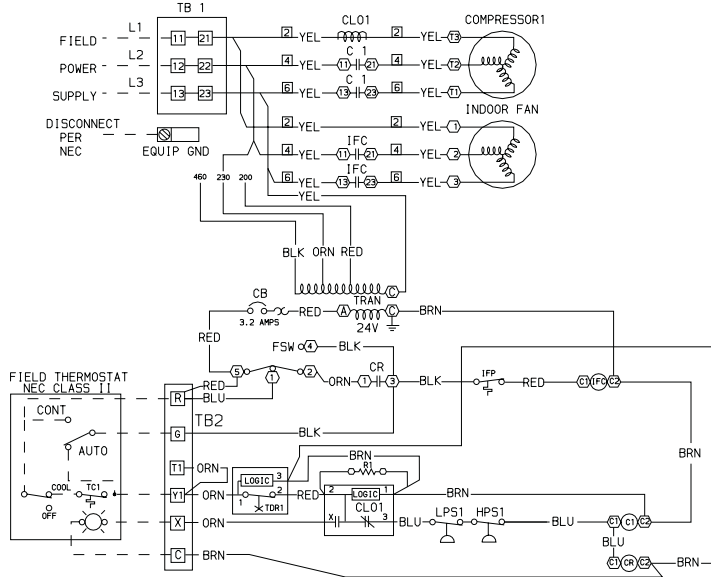

LEGEND

- C** — Compressor Contactor
- CB** — Circuit Breaker
- CLO** — Compressor Lockout
- CR** — Control Relay
- EQUIP** — Equipment
- FSW** — Fan Switch
- GND** — Ground
- HPS** — High-Pressure Switch
- IFC** — Indoor-Fan Contactor
- IFM** — Indoor-Fan Motor
- IFP** — Indoor-Fan Protector
- LPS** — Low-Pressure Switch
- NEC** — National Electrical Code
- TB** — Terminal Block
- TDR** — Time Delay Relay
- TRAN** — Transformer
- Terminal Box Connection
- Marked Terminal
- Unmarked Terminal
- Splice
- Factory Wiring
- Field Wiring

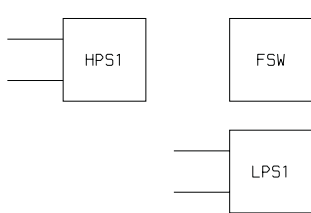

FSW
4 POSITION ROTARY SWITCH SCHEMATIC

POS	ANG*	1-2	1-4	1-5
1	0	-	-	-
2	90	-	X	X
3	180	X	-	X
4	270	-	X	X

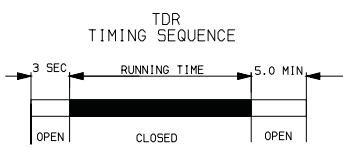
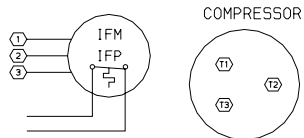

NOTES:

1. Fan motors are inherently thermally protected.
2. Three-phase motors are protected under primary single-phase conditions.
3. Use conductors suitable for at least 90 C (194 F) when replacing factory wiring.
4. Wiring for field power supply must be rated at 75 C (167 F) minimum.

Typical wiring schematics (cont)



50BRN,BZN12,014 UNITS

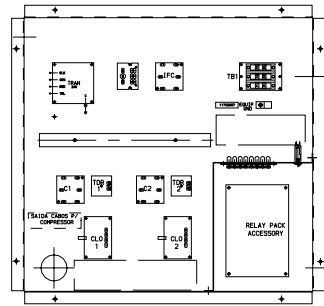
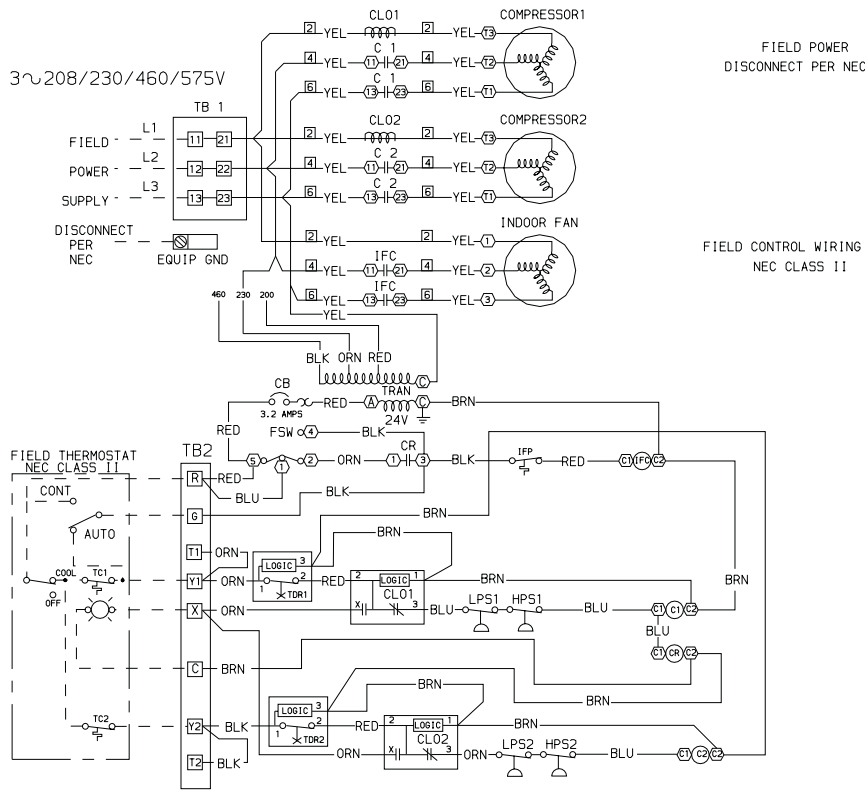

FIELD CONTROL WIRING
NEC CLASS II

LEGEND

- C** — Compressor Contactor
 - CB** — Circuit Breaker
 - CLO** — Compressor Lockout
 - CR** — Control Relay
 - EQUIP** — Equipment
 - FSW** — Fan Switch
 - GND** — Ground
 - HPS** — High-Pressure Switch
 - IFC** — Indoor-Fan Contactor
 - IFM** — Indoor-Fan Motor
 - IFP** — Indoor-Fan Protector
 - LPS** — Low-Pressure Switch
 - NEC** — National Electrical Code
 - TB** — Terminal Block
 - TDR** — Time Delay Relay
 - TRAN** — Transformer
-
- Terminal Box Connection
 - Marked Terminal
 - Unmarked Terminal
 - Splice
 - Factory Wiring
 - Field Wiring

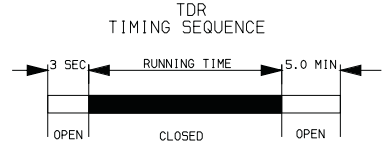
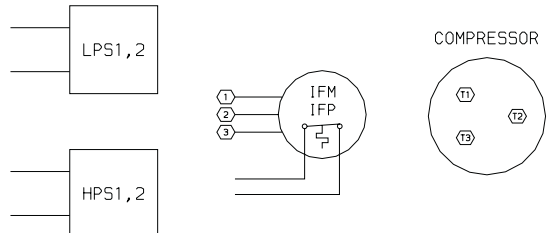

- NOTES:**
1. Fan motors are inherently thermally protected.
 2. Three-phase motors are protected under primary single-phase conditions.
 3. Use conductors suitable for at least 90 C (194 F) when replacing factory wiring.
 4. Use copper conductors only.
 5. Wiring for field power supply must be rated at 75 C (167 F) minimum.

50BRN,BZN016 UNITS

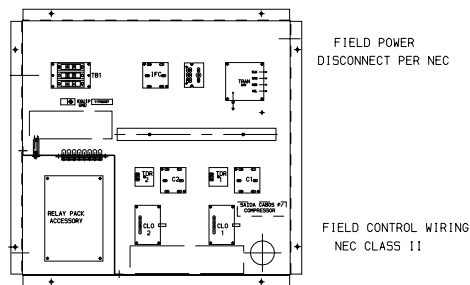
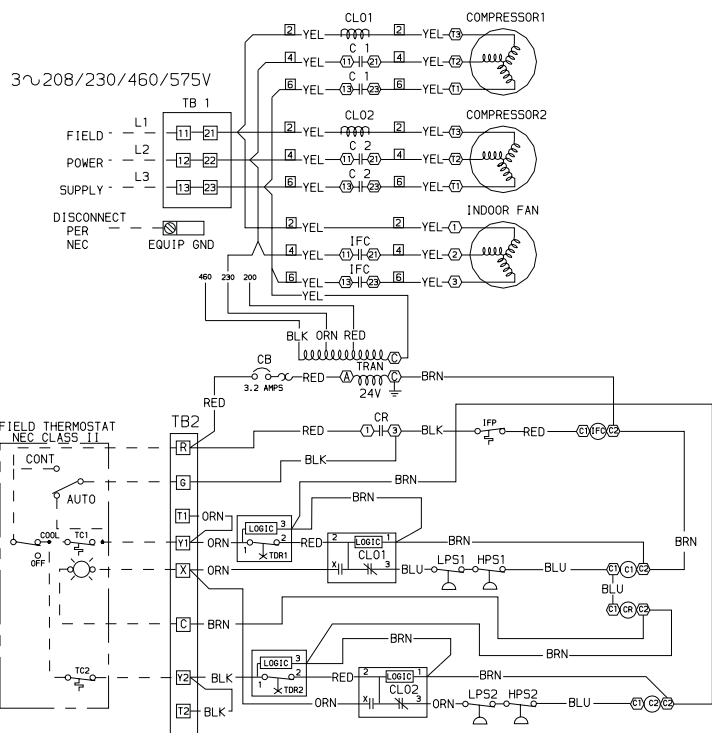

LEGEND

- C** — Compressor Contactor
- CB** — Circuit Breaker
- CLO** — Compressor Lockout
- CR** — Control Relay
- EQUIP** — Equipment
- GND** — Ground
- HPS** — High-Pressure Switch
- IFC** — Indoor-Fan Contactor
- IFM** — Indoor-Fan Motor
- IFP** — Indoor-Fan Protector
- LPS** — Low-Pressure Switch
- NEC** — National Electrical Code
- TB** — Terminal Block
- TDR** — Time Delay Relay
- TRAN** — Transformer
- Terminal Box Connection
- Marked Terminal
- Unmarked Terminal
- Splice
- Factory Wiring
- Field Wiring

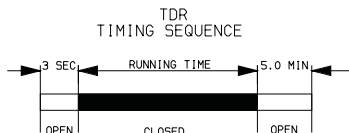
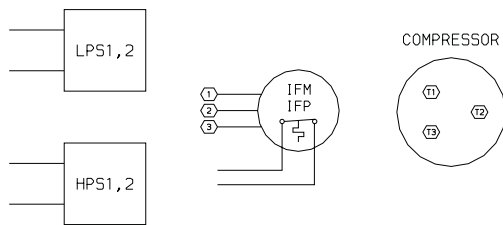

NOTES:

1. Fan motors are inherently thermally protected.
2. Three-phase motors are protected under primary single-phase conditions.
3. Use conductors suitable for at least 90 C (194 F) when replacing factory wiring.
4. Use copper conductors only.
5. Wiring for field power supply must be rated at 75 C (167 F) minimum.

Typical wiring schematics (cont)



50BRN024 UNITS

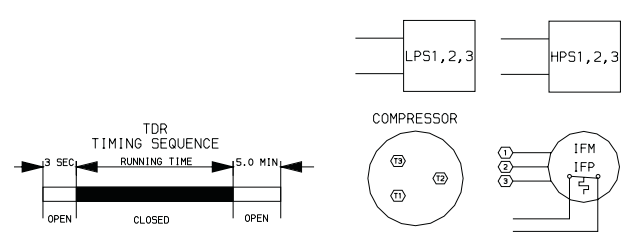
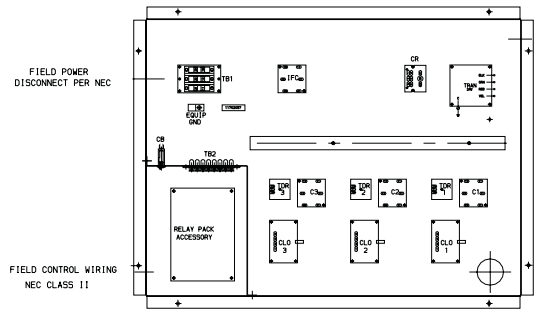
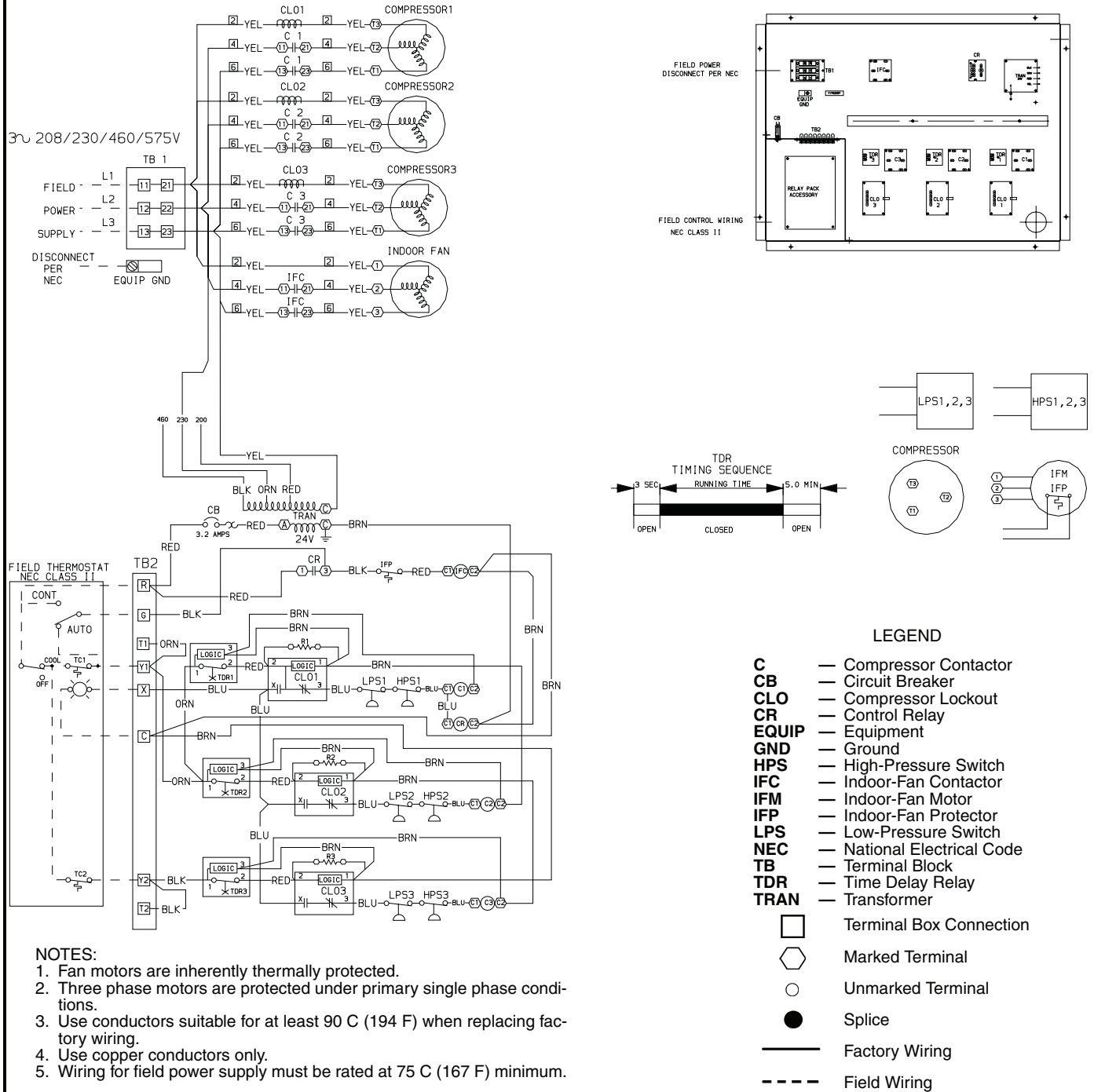

LEGEND

- C** — Compressor Contactor
- CB** — Circuit Breaker
- CLO** — Compressor Lockout
- CR** — Control Relay
- EQUIP** — Equipment
- GND** — Ground
- HPS** — High-Pressure Switch
- IFC** — Indoor-Fan Contactor
- IFM** — Indoor-Fan Motor
- IFP** — Indoor-Fan Protector
- LPS** — Low-Pressure Switch
- NEC** — National Electrical Code
- TB** — Terminal Block
- TDR** — Time Delay Relay
- TRAN** — Transformer
- Terminal Box Connection
- Marked Terminal
- Unmarked Terminal
- Splice
- Factory Wiring
- Field Wiring

- NOTES:**
1. Fan motors are inherently thermally protected.
 2. Three phase motors are protected under primary single phase conditions.
 3. Use conductors suitable for at least 90 C (194 F) when replacing factory wiring.
 4. Use copper conductors only.
 5. Wiring for field power supply must be rated at 75 C (167 F) minimum.

Controls



Operating sequence

All units require the addition of a thermostat accessory package to complete the control circuit. The sequence of operation may vary depending upon the package selected.

Room-mounted thermostat — The unit uses an electronic or mechanical thermostat mounted in the conditioned space.

Fan circulation — When the thermostat selector switch is set to the FAN position, the indoor-fan motor will operate to provide ventilation.

Cooling — The indoor fan will operate continuously or when the compressor runs, depending on the setting of the thermostat fan selector switch. When the thermostat closes (on a call for cooling), the control relay closes. This will immediately close the first stage compressors' contactors. The 50BRN024 unit is factory wired with 2 compressors on the first stage, and one on the second stage. This may be changed in the field (refer to the Application Data section of this book). A second stage will close if additional demand is required and will start the second stage compressor. When the thermostat is satisfied, the second stage compressor will stop, and then the first stage compressors will stop. A 5-minute timer will prevent the compressor(s) from restarting within 5 minutes from when the compressor(s) have stopped.

Heating — The indoor fan will operate continuously or when the compressor runs, depending on the setting of the

thermostat fan selector switch. When the thermostat closes (on a call for heating), the thermostat activates the water or steam control valve to meet the heating requirements.

Carrier TEMP System thermostat — The Carrier TEMP System thermostat works like a room thermostat, but provides for communicating control and interface to VVT® (variable air volume and temperature) systems. Both the control and the interface require an accessory relay pack, which may be mounted in the low-voltage control compartment. System operation with the Carrier TEMP System thermostat is the same as for the room-mounted thermostat.

Lockout relay — The unit's control circuit incorporates a current-sensing lockout relay (Cycle-LOC™) that locks off the compressor(s) when any safety device is activated. These devices include low or high-pressure switches or compressor internal overload. If any compressor safety device opens, the compressor(s) will stop and a 24-v signal will be sent to the X connection of the low-voltage terminal strip. The signal may be used to light an indicator on the thermostat to show that service is required. Since the unit is protected by the Cycle-LOC device, the compressor(s) will not restart following a safety interruption unless the thermostat is satisfied without cooling operation. To reset the Cycle-LOC control device, manually turn the control power to OFF and then back to the ON position.

Typical piping and wiring

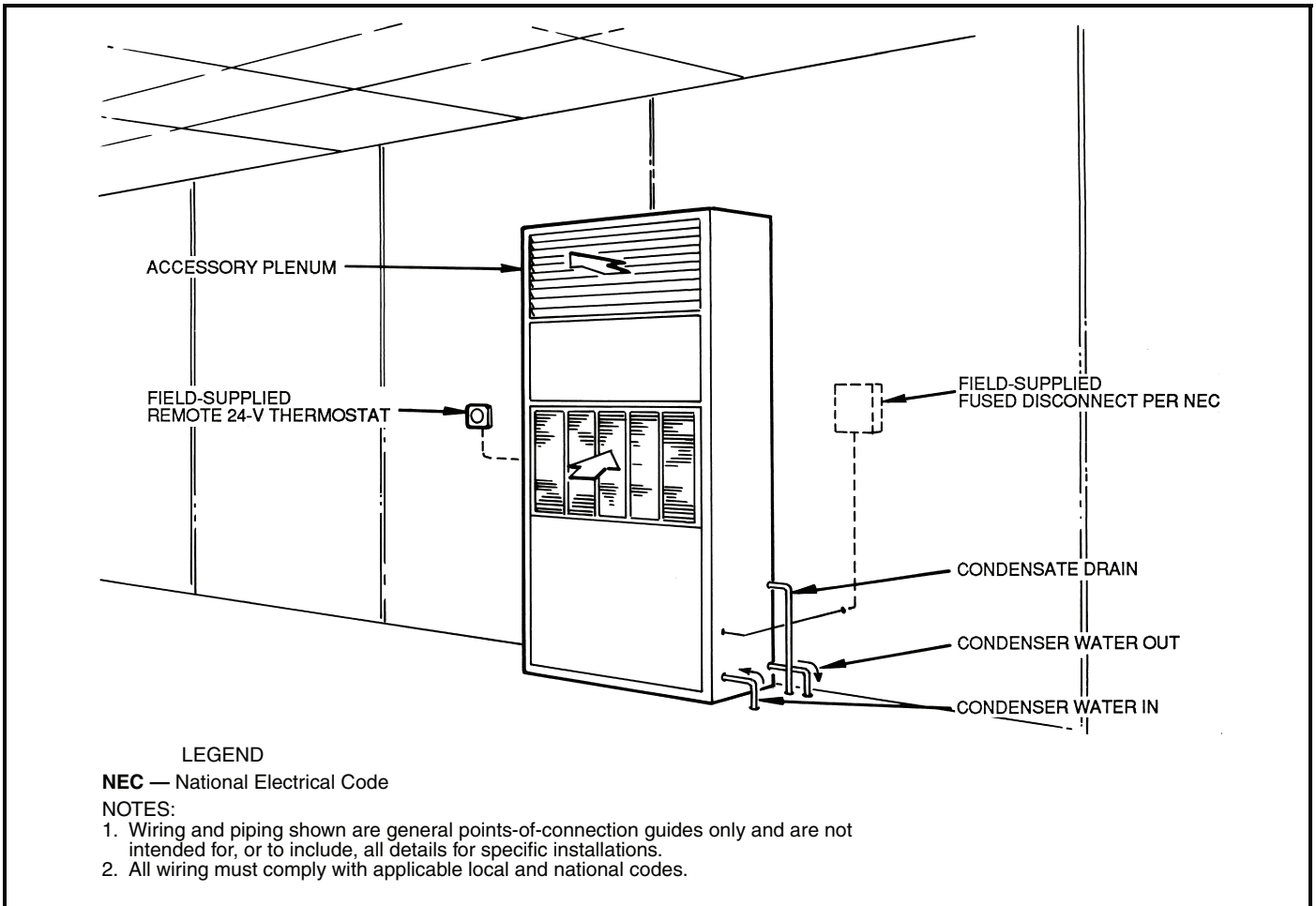

Application data



Location

For best results, the unit must be properly located and installed. Selected location should not be adjacent to an acoustically sensitive location such as a conference room or executive office. The best location is a mechanical room, next to elevators, restrooms or stairways. The mechanical room should be constructed to help isolate the transmission of acoustical energy.

Unit isolation

Unit compressors are internally isolated and the compressor compartment is lined with acoustical insulation. If additional vibration isolation is desired, rubber shear pads are recommended under the 4 corners of the unit. Spring isolation is not recommended.

Ductwork

The supply duct should be properly supported and the aspect ratio as close to square as possible. The duct should be sized for a maximum of 2000 ft/min. velocity in areas outside the equipment room. The duct should be lined with acoustical insulation for a minimum of 10 ft beyond the equipment room. A flexible duct connection should be used on the connection to the unit to prevent transmission of any unit vibrations into the duct.

A return duct may be attached to the unit, but is not necessary. The return to the unit should prevent line of sight visibility to the space. Insulation on the return duct is also recommended. The maximum velocity should not exceed 1000 ft/min. over occupied spaces. An adequate return area is essential for proper unit operation.

Piping

Recommended system piping configuration includes a reverse return system to minimize balancing. A strainer is recommended at the inlet to each unit to prevent sediments from plugging the condensers. Pressure gages are also recommended before the strainer and at the unit outlet to check any potential condenser fouling. Gate type isolation valves are also recommended at each unit to allow service without the need to drain the entire system.

Condenser head pressure control

When tower bypass control is not used and the unit will be required to operate with entering water temperatures below 55 F, a water regulating valve is required. The valve should be located on the water leaving side of the unit condenser. The valve is controlled by the refrigerant pressure of compressor number 1, using the refrigerant service gage port connection.

Operational limits

Air Flow: 200 to 500 cfm/ton
Air Temperature Cooling: Max 90 F, Min 70 F
Water Flow: 1.5 to 4.0 gpm/ton
Water Temperature: Max 105 F, Min 55 F

Water quality

A good water quality program will ensure years of trouble free unit operation. To establish the best program, a water treatment specialist should be consulted. As a guideline, the following recommendations are made.

Suspended solids over 25 microns (max.):	200 ppm
Chlorides (max.):	200 ppm
Carbon Dioxide (max.):	20 ppm
PH:	5.5
Sulfides:	< 0.1
Oxygen (max.):	1.0 ppm

Three independent circuit operation

Units have 3 compressors, each fully independent. Three-stage control is possible with a thermostat that will allow 3 stages of cooling. More likely, the third stage can be controlled by outdoor-air temperature to provide an additional stage with higher outdoor-air temperature. When staging the compressors, always stage the circuits such that the first compressor operating is the bottom circuit of the evaporator coil. After that, proceed up the coil in sequence.

Operation with dry cooler

The unit may be operated on a system that uses a dry cooler rather than a cooling tower. In this case, the saturated condensing temperature must be kept below 130 F for proper unit operation. If ethylene glycol is used in the system, the capacity must be adjusted for the solution concentration.

Operation on ethylene glycol

When the unit will be operated in a system that will use ethylene glycol to prevent freezing, the following table can be used to estimate system performance. Solution concentrations above 40% are not recommended. Capacity and pressure drop from the selection tables are multiplied by the percent factors in the table below.

% EG	% Capacity	% Pressure
0	100	100
10	98.8	104
20	97.2	108
30	95.6	114
40	95.6	124

LEGEND

EG — Ethylene Glycol

NOTE: Pressure drop is based on 85 F entering water with 10 F water temperature rise.

Application data (cont)



Refrigerant piping

For applications with condensers located above the cooling unit, hot gas loops above the condenser prevent liquid in condenser from draining at shutdown. Loops and check valves in the discharge line prevent oil and condenser refrigerant from draining to compressor at shutdown. If condenser is below the cooling unit, a loop at the condenser may be omitted. If piping runs prevent drainback, loops may be omitted.

Regardless of remote condenser location, a check valve must be installed in the discharge line in each refrigerant circuit, downstream from the hot-gas muffler, as close to compressor as possible. The check valve prevents migration of refrigerant back to the compressor.

Refrigerant piping OD should not be smaller than unit connection size.

Liquid lift

The amount of liquid lift available before refrigerant flashing occurs depends on the amount of liquid subcooling in the system.

All 09BY and 09DE condensers have positive subcooling when applied with optimum charge. With subcooling, it is possible to overcome an appreciable friction drop and/or static head (due to elevation of the liquid metering device above the condenser).

When 09BY and 09DE condensers are applied with minimum charge, no positive subcooling in condenser is realized; therefore, if subcooling is required it must be obtained by external means.

The average amount of liquid lift available from 09BY and 09DE condensers is shown in the accompanying table.

Winter start modifications

When starting 50BZN air-cooled units under low-ambient temperature conditions, the compressor may pull suction

pressure down below low-pressure switch cutout setting, causing the compressor to shut off. At extremely low ambient temperatures, the low-pressure switch may be open during the off cycle, preventing the compressor from starting. In these cases, winter start control is required.

AVAILABLE LIQUID LIFT (ft)* (R-22)

UNIT	TEMP DIFF (F)†	
	20	30
09BY006	65	61
09BY008	62	59
09BY012	65	61
09BY014	68	65
09BY016	70	66
09DE016	75	71

*Allows 7 psig drop for liquid line accessories and 2 F liquid line loss, with optimum charge.

†Condensing Temperature — Entering-Air Temperature (dry bulb).

NOTE: Data is based on 15 F subcooling.

CONDENSER USAGE

50BZN UNIT SIZE	CONDENSER QUANTITY REQUIRED					
	09BY					09DE
	006	008	012	014	016	016
006	1					
008		1				
012			1			
014*				1		1
016*					1	1

*Either the 09BY or the 09DE condenser can be used. Only one condenser is needed.

NOTE: Where there are no quantities of condensers listed, the combination is not recommended. See Application Data literature for more information on condenser combinations.

RECOMMENDED LINE SIZES (in.)

50BZN UNIT SIZE	CIRCUIT	UNIT CONNECT SIZE		LENGTH OF RUN (ft)											
				0 to 25		26 to 50		51 to 75		76 to 100		101 to 125		126 to 150	
		HG	LIQ	HG	LIQ	HG	LIQ	HG	LIQ	HG	LIQ	HG	LIQ	HG	LIQ
006	1	1/2	1/2	5/8	1/2	7/8	1/2	7/8	1/2	7/8	1/2	7/8	1/2	7/8	5/8
008	1	1/2	1/2	7/8	1/2	7/8	1/2	7/8	1/2	1 1/8	5/8	1 1/8	5/8	1 1/8	5/8
012	1	1/2	1/2	5/8	1/2	7/8	1/2	7/8	1/2	7/8	1/2	7/8	1/2	7/8	5/8
	2	1/2	1/2	5/8	1/2	7/8	1/2	7/8	1/2	7/8	1/2	7/8	1/2	7/8	5/8
014	1	1/2	1/2	7/8	1/2	7/8	1/2	7/8	1/2	1 1/8	5/8	1 1/8	5/8	1 1/8	5/8
	2	1/2	1/2	5/8	1/2	7/8	1/2	7/8	1/2	7/8	1/2	7/8	1/2	7/8	5/8
016	1	1/2	1/2	7/8	1/2	7/8	1/2	7/8	1/2	1 1/8	5/8	1 1/8	5/8	1 1/8	5/8
	2	1/2	1/2	7/8	1/2	7/8	1/2	7/8	1/2	1 1/8	5/8	1 1/8	5/8	1 1/8	5/8

LEGEND

HG — Hot Gas
LIQ — Liquid

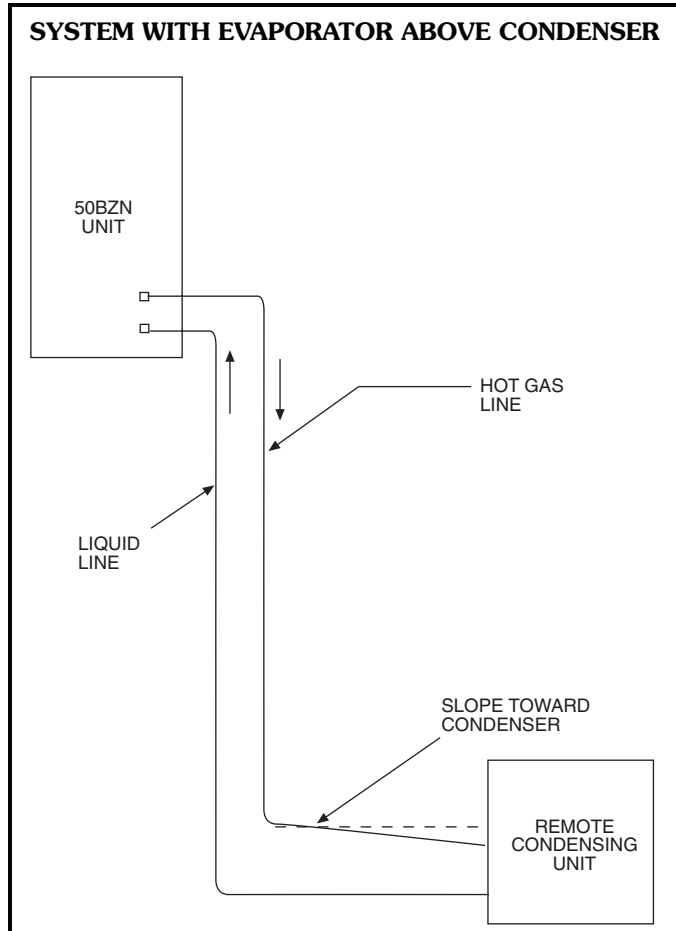
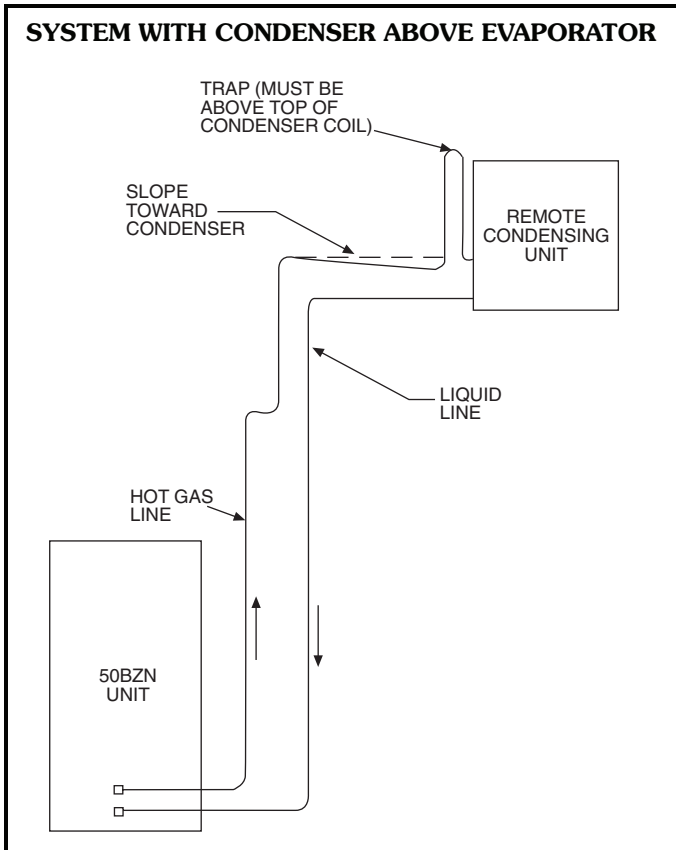



Indoor Packaged Water-Cooled Unit Constant Volume Application

HVAC Guide Specifications

Size Range: **5 to 20 Tons**

Carrier Model Number: **50BRN**

Part 1 — General

1.01 SYSTEM DESCRIPTION

Indoor vertical water-cooled packaged cooling unit utilizing a hermetic scroll compressor(s) for cooling duty.

1.02 QUALITY ASSURANCE

- A. Units shall be rated in accordance with ARI Standard 210/240 or 360.
- B. Unit shall be designed to conform to ANSI/ASHRAE 15, latest revision safety code, and UL Standard 1995, and shall be UL listed under both American and Canadian Standards.
- C. Insulation and adhesive shall meet NFPA 90A requirements for flame spread and smoke generation.

1.03 DELIVERY, STORAGE AND HANDLING

Units shall be stored and handled according to manufacturer's recommendations.

Part 2 — Products

2.01 EQUIPMENT

A. General:

Factory-assembled, single-piece, water-cooled cooling unit consisting of scroll refrigerant compressor(s), fan section with belt drive centrifugal fan(s) and motor, coil section with direct expansion coil and drain pan, water-cooled compact brazed plate condenser, factory wiring, piping and controls, and a system charge of refrigerant (R-22) included. Unit may be used with or without ductwork.

B. Unit Cabinet:

1. Cabinet shall be constructed of zinc surface alloyed steel with a baked enamel finish. Unit shall be capable of withstanding ASTM B117 500-hour salt spray test.
2. Cabinet shall be fully insulated. Evaporator section shall have a full metal liner and condenser section shall have full sound attenuating insulation. Units shall be capable of withstanding ARI insulating efficiency test at minimum airflow without cabinet sweating.
3. Unit drain pan shall have positive slope to the drain to prevent standing water in pan.
4. Panels for servicing shall be easily removable using a single wrench size.
5. Return grilles on all units except sizes 016 and 024.

C. Fan Section:

1. Fan shall be double inlet, centrifugal wheel with forward curved blades, designed for continuous operation. Fan wheel and scroll shall be

constructed of steel with corrosion resistant finish, and statically and dynamically balanced.

2. Fan shall be belt drive with an adjustable pitch motor pulley, with permanently lubricated, ball-bearing type bearings.
3. Fan shall be easily field convertible from vertical to horizontal discharge.

D. Compressor:

Hermetic scroll compressors, internally protected with high pressure relief. Compressors shall be factory rubber shock mounted with internal spring vibration isolators.

E. Coil:

1. Evaporator coil shall have aluminum plate fins mechanically bonded to seamless copper tubes with all joints brazed. Tube sheet openings shall be swaged to prevent tube wear.
2. Direct expansion coil shall be designed and tested in accordance with ANSI/ASHRAE 15, latest revision safety code.
3. Coil and drain pan shall be accessible through service access panels for cleaning.

F. Filter:

Filter frame shall be installed upstream of the cooling coil, to take a 1-in. thick cleanable or disposable type commercially available filter. Disposable filters will be supplied with the unit.

G. Condenser:

Condenser shall be single pass, water-cooled, ANSI type 316, stainless steel brazed plate construction and shall provide positive subcooling of liquid refrigerant. Condenser shall have a maximum working water side pressure of 400 psig. An independent condenser shall be provided for each refrigerant circuit.

H. Operating Characteristics:

Unit shall be capable of providing a constant volume of conditioned air at a specified static pressure within the unit's normal operating range. Air discharge to be horizontally free blow, or vertically through ductwork as shown on contract drawings. Unit shall have single-stage cooling capacity control (sizes 006,008) or 2-stage capacity control (sizes 012-024). Unit sizes 012-016 shall have 2 independent refrigerant circuits. Size 024 shall have 3 independent refrigerant circuits.

I. Controls and Safeties:

Unit shall have one of the following control systems:

1. Unit-mounted thermostat mounted in the unit return air. Unit shall be furnished with a factory-mounted fan control switch to control fan operation and turn off the unit.
2. Room-mounted thermostat shall be mounted in the conditioned space. Thermostat shall be either electromechanical or electronic type. Thermostat subbase shall control fan operation and be capable of turning unit on and off.



3. Room-mounted thermostat with communicating capability. This thermostat shall operate like the standard room-mounted thermostat and shall provide the additional benefit of being able to communicate with building systems to facilitate unit operation and control.

In addition, units shall have the following factory-installed safeties: high and low-pressure switches, overtemperature, current lockout, and inherent automatic fan motor overload.

J. Electrical Requirements:

All electrical wiring shall enter the unit cabinet at a single location. Control circuit is 24-v, suitable for powering a field-supplied 24-v thermostat.

K. Refrigerant Components:

Refrigerant circuit components include thermal expansion valve(s), filter drier(s), and charging service valve(s).

L. Special Features:

1. Air Discharge Plenum:

Plenum shall be provided to permit free-blow horizontal air distribution with movable vanes to

adjust airflow in horizontal and vertical direction. Plenum is field-installed and shall be fully insulated.

2. Heating Coil:

Field-installed steam coil shall be one row, or hot water coil will be 2 rows with copper tube aluminum spiral fins and a galvanized steel casing. Fins shall be bonded to tubes by mechanical expansion. Coil to be leak tested at 350 psig air pressure submerged in water and charged with dry air. Coil shall mount internal to the unit.

3. Thermostats:

A complete line of thermostats shall be available to meet any application control requirements.

4. Rear Return Filter Box:

A rear return filter box is available for unit sizes 006 to 014 to provide side access filter rack when air is through rear return connection.



Indoor Packaged Remote Air-Cooled Unit Constant Volume Application

HVAC Guide Specifications

Size Range: **5 to 15 Tons**

Carrier Model Number: **50BZN**

Part 1 — General

1.01 SYSTEM DESCRIPTION

Indoor vertical condenserless packaged cooling unit utilizing hermetic scroll compressor(s) for cooling duty.

1.02 QUALITY ASSURANCE

- A. Units shall be rated in accordance with ARI Standard 210/240 or 360.
- B. Unit shall be designed to conform to ANSI/ASHRAE 15, latest revision safety code, and UL Standard 1995, and shall be UL listed under both American and Canadian Standards.
- C. Insulation and adhesive shall meet NFPA 90A requirements for flame spread and smoke generation.

1.03 DELIVERY, STORAGE AND HANDLING

Units shall be stored and handled according to manufacturer's recommendations.

Part 2 — Products

2.01 EQUIPMENT

A. General:

Factory-assembled, single-piece, condenserless cooling unit consisting of hermetic scroll refrigerant compressor(s), fan section with belt drive centrifugal fan(s) and motor, coil section with direct expansion coil and drain pan, factory wiring, piping, and controls. A shipping charge of nitrogen shall be included.

B. Unit Cabinet:

1. Cabinet shall be constructed of zinc surface alloyed steel with a baked enamel finish. Unit shall be capable of withstanding ASTM B117 500-hour salt spray test.
2. Cabinet shall be fully insulated. Evaporator section shall have a full metal liner and condenser section shall have full sound attenuating insulation. Units shall be capable of withstanding ARI insulating efficiency test at minimum airflow without cabinet sweating.
3. Unit drain pan shall have positive slope to the drain to prevent standing water in pan.
4. Panels for servicing shall be easily removable using a single wrench size.
5. Return grilles on all units except size 016.

C. Fan Section:

1. Fan shall be double inlet, centrifugal wheel with forward curved blades, designed for continuous operation. Fan wheel and scroll shall be constructed of steel with corrosion resistant finish and statically and dynamically balanced.

2. Fan shall be belt drive with an adjustable pitch motor pulley with permanently lubricated, ball-bearing type bearings.
3. Fan shall be easily field convertible from vertical to horizontal discharge.

D. Compressor:

Hermetic scroll compressors, internally protected with high pressure relief. Compressors shall be factory rubber shock mounted with internal spring vibration isolators.

E. Coil:

1. Evaporator coil shall have aluminum plate fins mechanically bonded to seamless copper tubes with all joints brazed. Tube sheet openings shall be swaged to prevent tube wear.
2. Direct expansion coil shall be designed and tested in accordance with ANSI/ASHRAE 15, latest revision safety code.
3. Coil and drain pan shall be accessible through service access panels for cleaning.

F. Filter:

Filter frame shall be installed upstream of the cooling coil to take a 1-in. thick cleanable or disposable type commercially available filter. Disposable filters will be supplied with the unit.

G. Operating Characteristics:

Unit shall be capable of providing a constant volume of conditioned air at a specified static pressure within the unit's normal operating range. Air discharge to be horizontally free blow, or vertically through ductwork as shown on contract drawings. Unit shall have single-stage cooling capacity control (sizes 006,008) or 2-stage capacity control (sizes 012-016). Sizes 012-016 shall have 2 independent refrigerant circuits.

H. Controls and Safeties:

Unit shall have one of the following control systems:

1. Room-mounted thermostat shall be mounted in the conditioned space. Thermostat shall be either electromechanical or electronic type. Thermostat subbase shall control fan operation and be capable of turning unit on and off.
2. Room-mounted thermostat with communicating capability. This thermostat shall operate like the standard room-mounted thermostat, and shall provide the additional benefit of being able to communicate with building systems to facilitate unit operation and control.

In addition, units shall have the following factory-installed safeties: high and low-pressure switches, overtemperature, current lockout, and inherent automatic fan motor overload.

I. Electrical Requirements:

All electrical wiring shall enter the unit cabinet at a single location. Control circuit is 24-v, suitable for powering a field-supplied 24-v thermostat.



J. Refrigerant Components:

Refrigerant circuit components include thermal expansion valve(s), filter drier(s), and charging service valve(s).

K. Special Features:

1. Air Discharge Plenum:

Plenum shall be provided to permit free-blow horizontal air distribution with movable vanes to adjust airflow adjustment in horizontal and vertical direction. Plenum is field installed and shall be fully insulated.

2. Heating Coil:

Field-installed steam coil shall be one row, or hot water coil will be two rows with copper tube aluminum spiral fins and a galvanized steel casing. Fins shall be bonded to tubes by mechanical expansion. Coil to be leak tested at 350 psig air pressure submerged in water and

charged with dry air. Coil shall mount internal to the unit.

3. Evaporator Defrost Thermostat Package:

Shall maintain freeze protection under low ambient conditions.

4. Thermostats:

A complete line of thermostats shall be available to meet any application control requirements.

5. Liquid Line Solenoid:

The liquid line solenoid accessory shall be used on long-line applications and shall provide a shutoff valve to start and stop refrigerant flow.

6. Rear Return Filter Box:

A rear return filter box is available for unit sizes 006 to 014 to provide side access filter rack when air is through rear return connection.

