

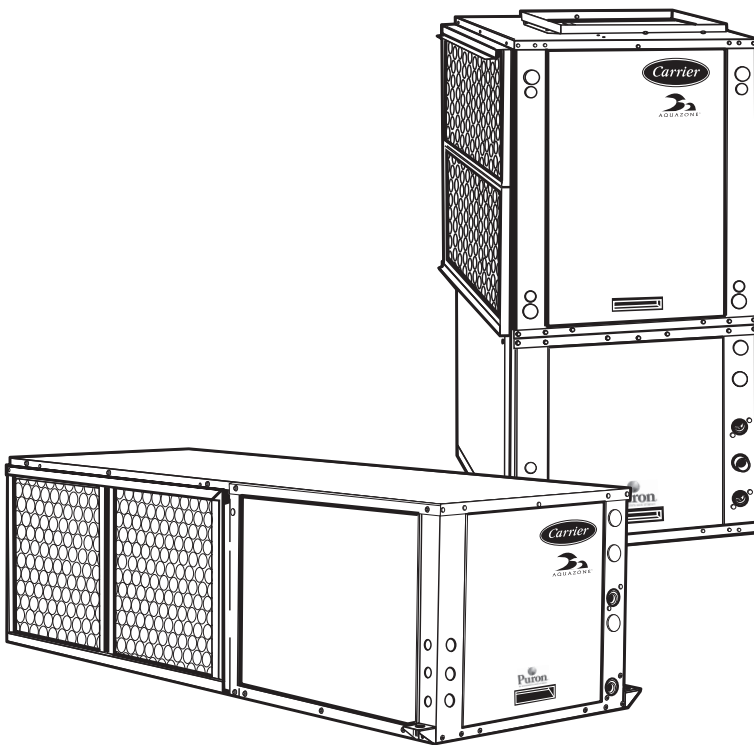

Product Data

AQUAZONE™ 50P1H, P1V006-060 Single-Stage Water Source Heat Pumps with PURON® Refrigerant (R-410A)

1/2 to 5 Nominal Tons



Single-package horizontally and vertically mounted water source heat pumps with electronic controls offer:

- Non-ozone depleting Puron refrigerant (R-410A)
- Three-speed PSC direct-drive, permanently lubricated fan motor (two-speed on 575-v units)
- E-coated air coil available
- Mute package for quieter operation available
- Versatility: apply to commercial boiler/cooling tower or geothermal applications (select extended range option for use in geothermal applications)
- Performance certified to AHRI/ISO 13256-1
- Exceeds ASHRAE 90.1 performance requirement efficiencies
- Flexible and reliable multiple protocol WSHP Open controller can use BACnet, Modbus, N2, and LON (with a separate card) protocols for integrating energy efficiency and precise unit control
- Eligible for additional LEED® (Leadership in Engineering and Environmental Design) points

Features/Benefits

The Aquazone single-stage water source heat pump with Puron refrigerant (R-410A) is a high quality, efficient solution for all boiler/tower and geothermal applications.

Operating efficiency

Carrier water source heat pumps (WSHPs) are designed for quality and high performance over a lifetime of operation.

**ASHRAE
90.1
COMPLIANT**

Well exceeds
ASHRAE 90.1 and
Energy Star Standards.

Puron®
the environmentally sound refrigerant

Features/Benefits (cont)



Single-stage WSHP models with Puron refrigerant (R-410A) offer cooling EERs (Energy Efficiency Ratios) to 24.5 and heating COPs (Coefficient of Performance) to 5.0.

All efficiencies stated are in accordance with standard conditions under ISO (International Organization for Standardization) Standard 13256-1 and provide among the highest ratings in the industry, exceeding ASHRAE (American Society of Heating, Refrigeration and Air Conditioning Engineers) 90.1 Energy Standards.

High quality construction and testing

All units are manufactured to meet extensive quality control protocol from start to finish through an automated control system, which provides continuous monitoring of each unit and performs quality control checks as equipment progresses through the production process. Standard construction features of the Aquazone™ units include:

Cabinet — Standard unit fabrication consists of heavy gage galvanized sheet metal cabinet construction designed for part standardization (i.e., minimal number of parts) and modular design. Compressor section interior surfaces are lined with 1/2 in. thick, dual density, 1 1/2 lb per cubic ft acoustic type fiberglass insulation. Air-handling section interior surfaces are lined with 1/2 in. thick, single density, 1 1/2 lb per cubic ft foil-backed fiber insulation for ease of cleaning. Insulation placement is designed to eliminate any exposed

edges to prevent the introduction of glass fibers into the airstream.

Horizontal and vertical water source heat pumps are fabricated from heavy gage galvanized steel with a powder coat paint finish on the front access panel.

Compressor — Aquazone 50P1 single-stage units include a rotary compressor in sizes 006-018 and a scroll compressor in sizes 024-060. Single-stage models with Puron® refrigerant (R-410A) offer a dual level vibration isolation system. The compressor is mounted on computer selected vibration isolation springs to a large heavy gage compressor mounting tray plate, which is then isolated from the cabinet base with rubber grommets for maximized vibration attenuation. The compressor has thermal overload protection and is located in an insulated compartment away from the airstream to minimize sound transmission.

AHRI/ISO labels — Aquazone units have AHRI (Air Conditioning, Heating, and Refrigeration Institute)/ISO, NRTL (Nationally Recognized Testing Lab), or ETL labels and are factory tested under normal operating conditions at nominal water flow rates. Quality assurance is provided via testing report cards shipped with each unit to indicate specific unit performance under cooling and heating modes of operation.

Blower and motor assembly — Aquazone 50P1 units are available with permanent split capacitor (PSC) or high-static PSC motors.

NOTE: The PSC and high-static PSC blower motors, when used with a

Thermidistat™ device and/or a humidistat and the Deluxe D controls, allow for intelligent fan speed reduction to provide the IdealHumidity™ system. The variable-speed blower systems work in concert with the Thermidistat and/or humidistat control to remove more moisture than a standard system, making the occupants feel cool and more comfortable.

Refrigeration/water circuit — All units contain sealed Puron refrigerant (R-410A) circuits including a high-efficiency hermetic compressor designed for heat pump operation, a thermostatic expansion valve for refrigerant metering, an enhanced corrugated aluminum-lanced fin and rifled copper tube refrigerant-to-air heat exchanger, reversing valve, coaxial (tube-in-tube) refrigerant-to-water heat exchanger, and safety controls including a high-pressure switch, low-pressure switch, water coil low temperature sensor, and air coil low temperature sensor.

Quiet operation

Fan motor insulation and double isolated compressor are provided for sound isolation, cabinets are fully insulated to reduce noise transmission, low speed blowers are utilized for quiet operation through reduced outlet air velocities, and air-to-refrigerant coils are designed for lower airflow coil face velocities. Additional sound mitigation can be attained with the mute package option.

Puron® refrigerant (R-410A)

Puron refrigerant (R-410A) is a non-chlorine based refrigerant. Puron refrigerant characteristics, compared to R-22, have:

- Binary and near azeotropic mixture of 50% R-32 and 50% R-125.
- Higher efficiencies (50 to 60% higher operating pressures).
- Non-ozone depleting potential and low global warming potential.
- Virtually no glide. Unlike other alternative refrigerants, the two components in Puron refrigerant have virtually the same leak rates. Therefore, refrigerant can be added if necessary without recovering the charge.

Table of contents

	Page
Features/Benefits	1-5
Model Number Nomenclature	5
AHRI/ASHRAE/ISO 13256-1 Capacity Ratings	6
Physical Data	7
Options and Accessories	8-10
Dimensions	11,12
Selection Procedure	13
Performance Data	14-28
Electrical Data	29-32
Typical Piping and Wiring	33
Typical Control Wiring Schematics	34-45
Application Data	46-51
Controls	52-55
Guide Specifications	56-61



E-coated (electro-coated) air coils

The 50P1H and P1V units are available with an optional e-coated air coil. This electro-coating process will provide years of protection against corrosion from airborne chemicals. Modern building materials, such as countertops, floor coverings, paints and other materials, can “outgas” chemicals into the indoor air. Some of these chemicals are suspected of contributing to corrosion in the air coils found in both traditional and geothermal heating and cooling equipment. Corrosion often results in refrigerant leaks and eventual failure of the air coil, costing hundreds of dollars to replace. Studies have also shown that these air coil coatings improve moisture shedding and therefore, improve a unit's moisture removal capability resulting in a more comfortable indoor environment. The 50P1H and P1V units assure both maximum air coil life and comfort.

Design flexibility

Airflow configurations for horizontal units are available in four patterns including left or right return, and left, right, or back discharge. Horizontal units are field convertible from left or right discharge to back discharge. Vertical units are available in three airflow patterns including top discharge with right or left return. Standard entering water temperature is between 60 and 95 F. Extended entering water temperature range between 20 and 120 F offers maximum design flexibility for all applications. Water flow rates as low as 1.5 gpm per ton assist with selection from a various range of circulating pumps. Factory-installed options are offered to meet specific design requirements.

Safe, reliable operation

Standard safety features for the refrigerant circuit include high-pressure switch, low-pressure sensor to detect loss of refrigerant, and low air temperature sensor to safeguard against freezing. Equipment safety features include water loop temperature monitoring, voltage protection, water coil freeze protection, and standard electronic condensate overflow shutdown. All safety features are tested and run at the factory to assure proper operation of all components and safety switches.

All components are carefully designed and selected for endurance durability, and carefree day-to-day operation.

The Aquazone™ unit is shipped to provide internal and external equipment protection. Shipping supports are placed under the blower housing and compressor feet. In addition, horizontal and vertical units are both mounted on oversized pallets with lag bolts for sturdiness and maximum protection during transit.

Ease of installation

The Aquazone unit is packaged for simple low cost handling, with minimal time required for installation. All units are pre-wired and factory charged with refrigerant. Horizontal units are provided with factory-installed hangar isolation brackets. Vertical units are provided with an internally trapped condensate drain to reduce labor associated with installing an external trap for each unit. Water connections (FPT) and condensate drains (FPT) are anchored securely to the unit cabinet, eliminating the need for backup wrenches.

Simple maintenance and serviceability

The Aquazone water source heat pump (WSHP) units are constructed to provide ease of maintenance. Units allow access to the compressor section from 3 sides and have large removable panels for easy access. Additional panels are provided to access the blower and control box sections.

The blower housing assembly can be serviced without disconnecting ductwork from the dedicated blower access panel. Blower units are provided with permanently lubricated bearings for worry-free performance. Blower inlet rings allow removal of the blower wheel without having to remove the housing or ductwork connections.

Electrical disconnection of the blower motor and control box is easily accomplished from quick disconnects on each component.

Easy removal of the control box from the unit provides access to all refrigeration components.

The refrigeration circuit is easily tested and serviced through the use of high and low pressure ports integral to the refrigeration circuit.

Maximum control flexibility

Aquazone water source heat pumps provide reliable control operation using a standard microprocessor board with flexible alternatives for many direct digital controls (DDC) applications including the Carrier Comfort Network® (CCN) controls and open protocol systems.

The Aquazone standard unit solid-state control system, the Complete C, provides control of the unit compressor, reversing valve, fan, safety features, and troubleshooting fault indication features. The Complete C control system is one of the most user friendly, low cost, and advanced control boards found in the WSHP industry. Many features are field selectable to provide the ultimate in field installation flexibility. The overall features of this standard control system include:

50-va transformer — The transformer assists in accommodating accessory loads.

Anti-short cycle timer — The timer provides a minimum off time to prevent the unit from short cycling. The 5-minute timer energizes when the compressor is deenergized, resulting in a 5-minute delay before the unit can be restarted.

Random start relay — The random start relay ensures a random delay in energizing each different WSHP unit. This option minimizes peak electrical demand during start-up from different operating modes or after building power outages.

High and low pressure refrigerant protection — This protection safeguards against unreliable unit operation and provides a warning for refrigerant leaking.

Condensate overflow sensor — The electronic sensor is mounted to the drain pan. When condensate pan liquid reaches an unacceptable level, unit is automatically deactivated and placed in a lockout condition. Thirty continuous seconds of overflow is recognized as a fault by the sensor.

High and low voltage protection — Safety protection for excessive or low voltage conditions is included.

Automatic intelligent reset — The unit will automatically restart 5 minutes after shutdown if the fault has cleared. Should a fault occur 3 times sequentially, lockout will occur.

Features/Benefits (cont)



Accessory output — A 24-v output is provided to cycle a motorized water valve or damper actuator with compressor in applications such as variable speed pumping arrangements.

Performance Monitor (PM) — This unique feature monitors water temperatures to warn when the heat pump is operating inefficiently or beyond typical operating range. Field selectable switch initiates a warning code on the unit display.

Water coil freeze protection (selectable for water or antifreeze) — The field selectable switch for water and water/glycol solution systems initiates a fault when temperatures exceed the selected limit for 30 continuous seconds.

Air coil freeze protection (check filter operation) — The field selectable switch for assessing excessive filter pressure drop initiates a fault when temperatures exceed the selected limit for 30 continuous seconds.

Alarm relay setting — A selectable 24-v or pilot duty dry contact provides activation of a remote alarm.

Electric heat option — The output provided on the controller operates two stages of emergency electric heat.

Service Test mode with diagnostic LED (light-emitting diode) — The Service Test mode allows service personnel to check the operation of the WSHP and control system efficiently. Upon entering Service Test mode, time delays are sped up, and the Status LED will flash a code to indicate the last fault experienced for easy diagnosis. Based on the fault code flashed by the status LED, system diagnostics are assisted through the use of Carrier provided troubleshooting tables for easy reference to typical problems.

LED visual output — An LED panel indicates high pressure, low pressure, low voltage, high voltage, air/water freeze protection, condensate overflow, and control status.

WSHP Open multiple protocol controller — Carrier's state of the art water source heat pump multiple protocol controller is capable of communicating BACnet*, Modbus†, N2 and LON (with a separate card) protocols. The controller is designed specifically for Carrier's WSHPs in order to bring more features and benefits to the units

such as waterside economizer control, auxiliary heat, dehumidification, etc., in addition to independent compressor and fan operation. The WSHP Open controller can be used to actively monitor and control all modes of operation as well as monitor the following diagnostics and features: unit number, zone temperature, zone set point, zone humidity set point, discharge air temperatures, fan status, stages of heating, stages of cooling, outdoor-air temperature, leaving-air temperature, leaving water temperature, alarm status, and alarm lockout condition.

The controller also provides a proactive approach to maintenance and service enabling the unit to recognize and correct operating conditions outside of recommended operating conditions avoiding the need to manually restart equipment. From a system standpoint WSHP Open controller can accept both water and airside linkage.

Condenser water linkage provides optimized water loop operation using the UC (universal controller) Open XP loop controller. Loop pump operation is automatically controlled by WSHP equipment occupancy schedules, unoccupied demand and tenant override conditions. Positive pump status feedback prevents nuisance fault trips.

Airside linkage enables the WSHP equipment to be completely integrated with the Carrier's VVT® application as a system. The WSHP Open controller responds to individual zone demands rather than average temperature conditions to provide individual temperature control in each zone.

This controller has a 38.4 kilobaud communications capability and is compatible with i-Vu® Open building automation system controls and CCN controls. The addition of the Carrier CO₂ sensor in the conditioned space provides ASHRAE 62 compliance and demand controlled ventilation (DCV). A DCV control strategy is especially beneficial for a water source heat pump system to minimize the energy utilized to condition ventilation air. In combination with energy efficient Aquazone units, DCV may be the most energy efficient approach ever developed for a water source heat pump system.

The WSHP Open multiple protocol controller is designed specifically for constant volume (CV) and variable volume and temperature (VVT®) applications. This comprehensive controls

system allows water source heat pumps to be linked together to create a fully functional HVAC (heating, ventilation, and air conditioning) automation system.

PremierLink™ controller adds reliability, efficiency, and simplification

The PremierLink direct digital controller can be ordered as a factory-installed option. Designed and manufactured exclusively by Carrier, the controller can be used to actively monitor and control all modes of operation as well as monitor the following diagnostics and features: unit number, zone temperature, zone set point, zone humidity set point, discharge air temperatures, fan status, stages of heating, stages of cooling, outdoor-air temperature, leaving-air temperature, leaving water temperature, alarm status, and alarm lockout condition.

This controller has a 38.4 kilobaud communications capability and is compatible with i-Vu Open building automation system controls and CCN controls. The addition of the Carrier CO₂ sensor in the conditioned space provides ASHRAE 62-99 compliance and demand controlled ventilation (DCV). A DCV control strategy is especially beneficial for a water source heat pump system to minimize the energy utilized to condition ventilation air. In combination with energy efficient Aquazone units, DCV may be the most energy efficient approach ever developed for a water source heat pump system.

The PremierLink peer-to-peer, Internet ready communicating control is designed specifically for constant volume (CV) and variable volume and temperature (VVT®) applications. This comprehensive controls system allows water source heat pumps to be linked together to create a fully functional HVAC (heating, ventilation, and air conditioning) automation system.

LON protocol for diverse control — The LON controller option is ideal when building automation requires interoperability across diverse control platforms. This LONMark** compliant offering can operate as standalone or as a part of Local Operating Network (LON) via the LonWorks** FTT-10 Free Topology communication network. Factory completed pre-engineered applications specific to Aquazone water source heat pumps and



digital wall sensors communicating over Sensor Link (S-Link) communication protocol completes a system of networked control.

Humidity control — Aquazone 50P1H, P1V units provide very good latent capacity and are an excellent choice for controlling humidity within a zone in many applications. The latent capacity of the units can be increased based on zone conditions with either

the use of fan speed control and a humidistat. The Deluxe D controls option provides fan speed control based on relative humidity and is an effective, low-cost means of controlling humidity in some parts of North America.

*Sponsored by ASHRAE (American Society of Heating, Refrigerating, and Air Conditioning Engineers).

†Registered trademark of Schneider Electric.

**Registered trademark of Echelon Corporation.

Model number nomenclature

50P1V 024 J C C 3 0 1 3 0

Aquazone™ Single Stage Water Source Heat Pump with Puron® Refrigerant (R-410A)
50P1H – Horizontal Configuration
50P1V – Vertical Upflow Configuration

Size – Nominal Tons
006 – 1/2 **018** – 1-1/2 **042** – 3-1/2
009 – 3/4 **024** – 2 **048** – 4
012 – 1 **030** – 2-1/2 **060** – 5
015 – 1-1/4 **036** – 3

Airflow Configuration*
50P1H Units

Option	Return	Discharge	Blower Motor
A	Right	Left	PSC HS
B	Right	Back	PSC
C	Right	Back	PSC HS
D	Left	Right	PSC HS
E	Left	Back	PSC
F	Left	Back	PSC HS
S	Left	Right	PSC
Z	Right	Left	PSC

50P1V Units

Option	Return	Discharge	Blower Motor
G	Right	Top	PSC HS
H	Front	Top	PSC HS
J	Front	Top	PSC
L	Left	Top	PSC
M	Left	Top	PSC HS
R	Right	Top	PSC

Control
C – Complete C Microprocessor Control
D – Deluxe D Microprocessor Control
L – Complete C with LON†
M – Deluxe D with LON†
P – Complete C with PremierLink™ Control
W – Complete C with WSHP Open Multiple Protocol Communicating Control**
Y – Deluxe D with WSHP Open Multiple Protocol Communicating Control**

Water Circuit Options
0 – None
8 – Auto Flow Regulator Sized for 2.5 Gpm/Ton
9 – Auto Flow Regulator Sized for 3.0 Gpm/Ton

Operating Range/Sound Option
1 – Extended EWT Range (20 to 110 F)
2 – Extended EWT Range with Mute Package
3 – Standard EWT Range (60 to 95 F)
4 – Standard EWT Range with Mute Package

Packaging
1 – Single Pack, Domestic

Revision Code
0 – Current Revision

Voltage ††
1 – 575-3-60
3 – 208/230-1-60
4 – 265-1-60
5 – 208/230-3-60
6 – 460-3-60

Heat Exchanger Options

Valve	Non Coated Air Coil		Coated Air Coil	
	Copper	Cupronickel	Copper	Cupronickel
None	C	N	A	J
Motorized Valve	T	S	U	W

LEGEND

EWT — Entering Water Temperature
HS — High Static
LON — Local Operating Network
PSC — Permanent Split Capacitor

*PSC HS motors not available for sizes 006-012.

†LONWorks Open System Protocol.

**BACview6 handheld device or USBLINK are required for commissioning.

††The 460-v units using internal secondary pump and/or modulating hot water heat (pump) will require a neutral wire.



AHRI/ASHRAE/ISO 13256-1 capacity ratings



50P1 UNIT SIZE	WATER LOOP HEAT PUMP				GROUND WATER HEAT PUMP				GROUND LOOP HEAT PUMP			
	Cooling 86 F		Heating 68 F		Cooling 59 F		Heating 50 F		Cooling 77 F		Heating 32 F	
	Capacity Btuh	EER (Btuh/W)	Capacity Btuh	COP	Capacity Btuh	EER (Btuh/W)	Capacity Btuh	COP	Capacity Btuh	EER (Btuh/W)	Capacity Btuh	COP
006	5,800	13.2	7,500	4.7	6,900	21.1	6,200	4.0	6,200	15.4	4,900	3.4
009	8,800	13.4	11,600	4.2	10,100	21.0	9,800	3.9	9,300	15.7	7,900	3.4
012	11,700	13.5	15,200	4.3	13,700	20.8	12,500	3.8	12,000	14.9	9,900	3.2
015	14,500	15.4	17,300	5.0	16,800	24.5	14,400	4.4	15,000	17.2	11,100	3.6
018	17,300	14.3	21,500	5.0	20,600	24.2	17,200	4.4	18,400	16.3	13,900	3.4
024	23,700	13.4	28,500	4.7	26,700	20.9	24,000	4.1	24,900	15.4	18,500	3.3
030	28,100	13.4	35,100	4.6	31,700	20.1	29,600	4.1	28,900	15.1	23,400	3.4
036	34,500	13.5	45,200	4.4	38,700	20.7	37,500	4.0	35,300	14.9	29,600	3.3
042	40,100	13.1	52,700	4.3	45,900	19.6	44,000	3.8	40,500	14.4	34,300	3.2
048	47,700	13.3	55,900	4.7	54,300	20.5	46,500	4.1	49,000	14.7	36,400	3.4
060	59,400	13.4	77,000	4.3	66,600	19.9	64,000	3.8	60,100	14.8	50,500	3.1

LEGEND

COP — Coefficient of Performance
db — Dry Bulb
EER — Energy Efficiency Ratio
wb — Wet Bulb

NOTES:

1. Cooling capacities based upon 80.6 F db, 66.2 F wb entering air temperature.
2. Heating capacities based upon 68 F db, 59 F wb entering air temperature.
3. All ratings based upon operation at the lower voltage of dual voltage rated models.
4. Certified in accordance with the AHRI/ISO Standard 13256-1 Certification Program.



Physical data



50P1 UNIT SIZE	006	009	012	015	018	024	030	036	042	048	060
COMPRESSOR (1 Each)	Rotary					Scroll					
FACTORY CHARGE R-410A (oz)	17	18.5	23	35	43	43	48	50	70	74	82
PSC FAN MOTOR AND BLOWER (3 Speeds)											
Fan Motor (Hp)	1/25	1/10	1/10	1/6	1/6	1/4	3/4	1/2	3/4	3/4	1
High Static Fan Motor (Hp)											
Blower Wheel Size (D x W) (in.)	5 x 5	5 x 5	6 x 5	8 x 7	8 x 7	9 x 7	9 x 7	9 x 8	9 x 8	10 x 10	11 x 10
COAX VOLUME (gal.)	0.123	0.143	0.167	0.286	0.450	0.286	0.323	0.323	0.890	0.738	0.939
WATER CONNECTION SIZE, FPT (in.)	1/2	1/2	1/2	1/2	1/2	3/4	3/4	3/4	3/4	1	1
UNIT MAXIMUM WATER WORKING PRESSURE (psig)*											
Base Unit	500										
Internal Motorized Water Valve	300										
Internal Auto Flow Valve	500										
50P1V UNITS											
Air Coil Dimensions (H x W) (in.)	10 x 15	10 x 15	10 x 15	20 x 17 1/4	20 x 17 1/4	20 x 17 1/4	20 x 17 1/4	24 x 21 3/4	24 x 21 3/4	28 x 25	28 x 25
Throwaway Filter, Standard 1-in. Size	10 x 18	10 x 18	10 x 18	20 x 20	20 x 20	20 x 20	20 x 20	24 x 24	24 x 24	28 x 28	28 x 28
Weight											
Operating (lb)	110	112	121	163	168	184	192	213	228	283	298
Packaged (lb)	115	117	126	168	173	189	197	219	234	290	305
50P1H UNITS											
Air Coil Dimensions (H x W) (in.)	10 x 15	10 x 15	10 x 15	16 x 22	16 x 22	16 x 22	16 x 22	20 x 25	20 x 25	20 x 35	20 x 35
Throwaway Filter, Standard 1-in. Size	10 x 18	10 x 18	10 x 18	16 x 25	16 x 25	18 x 25	18 x 25	20 x 28 or (2) 20 x 14	20 x 28 or (2) 20 x 14	20 x 24, 20 x 14	20 x 24, 20 x 14
Weight											
Operating (lb)	110	112	121	163	168	184	192	213	228	283	298
Packaged (lb)	115	117	126	168	173	189	197	219	234	290	305

LEGEND

- FPT — Female Pipe Thread
- PSC — Permanent Split Capacitor
- TXV — Thermostatic Expansion Valve

*Use the lowest maximum pressure rating when multiple options are combined.

NOTE: All units have spring compressor mountings, TXV expansion devices, and 1/2-in. and 3/4-in. electrical knockouts.

UNIT CORNER WEIGHTS (lb)

UNIT SIZE 50P1H	TOTAL WEIGHT	LEFT FRONT	RIGHT FRONT	LEFT BACK	RIGHT BACK
006	110	40	20	25	25
009	112	41	21	25	25
012	121	45	22	27	27
015	163	54	44	33	33
018	168	55	45	34	34
024	184	61	50	37	37
030	192	63	52	38	38
036	213	70	58	43	43
042	228	75	62	46	46
048	283	93	76	57	57
060	298	98	80	60	60

NOTE: Front is control box end.

Options and accessories



ITEM	FACTORY-INSTALLED OPTIONS	FIELD-INSTALLED ACCESSORIES
Aquazone™ System Control Panel		X
2-in. Filter Rack		X
Ball Valves (Brass Body)		X
Permanent Split Capacitor, High Static Blower Motor	X	
Cupronickel Heat Exchangers	X	
Deluxe D Control System	X	
Extended Range Units	X	
Fire-Rated Hoses		X
Hose Kit Assemblies		X
PremierLink™ Intelligent Controller	X	
LONMark Compliant Controller	X	
UC Open XP Loop Controller		X
Non-Programmable Thermostat		X
PremierLink Accessories		X
Programmable 5-Day Thermostat		X
Programmable 7-Day Flush-Mount Thermostat		X
Programmable 7-Day Light-Activated Thermostat		X
Programmable 7-Day Thermostat		X
Remote Sensors (SPT, CO ₂ , Humidity Sensors)		X
Solenoid Water Control Valves (Brass Body)		X
Sound Attenuation (Mute) Package	X	
Two-Way Motorized Control Valve	X	X
Water Circuit Options	X	
Y Strainers (Brass Body)		X
WSHP Open Multiple Protocol Controller	X	

Factory-installed options

Cupronickel heat exchangers are available for higher corrosion protection for applications such as open tower, geothermal, etc. Consult the water quality guidelines for proper application and selection of this option.

Sound attenuation package (mute package) is available for applications that require especially low noise levels. With this option, a double application of sound attenuating material is applied, access panels are double dampened with 1/2-in. thick density fiberglass insulation, which is applied to the basepan, and a unique application of special dampening material is applied to the curved portion of the blower. The mute package in combination with standard unit noise reduction features (i.e., as mentioned previously) provides sound levels and noise reduction to the highest degree.

Extended range units have an insulated coaxial coil and insulated refrigerant and water piping to prevent condensation, and therefore potential dripping problems, in applications where the entering water temperature is below the normal operating range (less than 60 F). Units are capable of operating with an entering water temperature range of 20 to 120 F.

Water circuit options provide internally mounted 2.5 or 3.0 gpm per ton automatic flow regulating valves for easier installation.

Two-way motorized control valve can be provided for applications involving open type systems or variable speed pumping. This valve will slowly open and close in conjunction with the compressor operation to shut off or turn on water to the unit.

WSHP Open multiple protocol controller is a proactive controller capable of communicating BACnet, Modbus, N2, and LON (with a separate card) protocols. The controller is designed to allow users access and ability to change and configure multiple settings and features including indoor air quality (IAQ), waterside economizer controls, etc.

Deluxe D control system provides the same functions as the Complete C control system while incorporating additional flexibility and functions to include:

Thermostat input capabilities accommodate emergency shutdown mode and night setback with override potential. Night setback from low temperature thermostat with 2-hour override is initiated by a momentary signal from the thermostat.

Compressor relay staging is used with dual stage units (units with 2 compressors and 2 Deluxe D controls) or in master/slave applications.

Boilerless electric heat control system allows automatic changeover to electric heat at low loop water temperature.

Intelligent reversing valve operation minimizes reversing valve operation for extended life and quiet operation.

Thermostat type select (Y, O or Y, W) provides ability to work and select heat pump or heat/cool thermostats (Y, W).

Reversing valve signal select (O or B) provides selection for heat pump O/B thermostats.

The IdealHumidity™ system provides operation of fan control for dehumidification operation (units with ECM motor have input on the ECM board; optional Deluxe D board is not required).

Multiple units on one thermostat/wall sensor provides for communication for up to three heat pumps on one thermostat.

Boilerless changeover temperature provides selection of boilerless changeover temperature set point.

Accessory relays allow configuration for multiple applications including fan and compressor cycling, digital night setback (NSB), mechanical night setback, water valve operation, and outside air damper operation.

PremierLink™ controller is compatible with the Carrier Comfort Network® (CCN) and other building automation systems (BAS). This control is designed to allow users the access and ability to change factory-defined settings thus expanding the function of the standard unit.

LONMark compliant controller contains the factory-loaded Aquazone™ water source heat pump application for an interoperable control solution.

Permanent split capacitor (high static) blower motors enable the 50P1 units to increase performance levels in high-static applications.

Field-installed accessories

Aquazone™ system control panel includes a preprogrammed, easy to use, Carrier Comfort Controller set up for a WSHP system.

- Panel coordinates and monitors loop water temperature and all water side ancillary equipment.



- The 50RLP model nomenclature is used to customize the control panel options to control all WSHP system requirements.
- Panel can be ordered to include 2, 4, 6, or 8 stages of system heat rejection.
- Panel can be ordered to include 2, 4, 6, or 8 stages of system heat addition.
- Panel can be ordered with unique WSHP zone operation capabilities for stand-alone systems (i.e., noncommunicating) to control 10 or 18 zones of WSHP units.
- Panel can be ordered to control variable frequency cooling tower fan operation.
- System pumping operation can be configured for start/stop, lead/lag, or variable frequency pump operation.
- Direct Digital Controls (DDC) compatible using the Carrier Comfort Network® (CCN) and WSHP units utilizing PremierLink™ CCN controllers.

Carrier's line of Aquazone thermostats are both attractive and multi-functional, accommodating stand-alone water source heat pump installations.

Programmable 7-day thermostat — Thermostat offers 2-stage heat, 2-stage cool, auto changeover, 7-day programmable with copy command, 4 settings per day, fully electronic, 24 vac, backlit LCD, keypad lockout, no batteries required, 5-minute compressor protection, NEVERLOST™ memory, 3 security levels, and temperature display in degrees F or C.

Programmable 7-day light-activated thermostat — Thermostat offers same features as the 7-day programmable thermostat and includes occupied comfort settings with lights on, unoccupied energy savings with lights off.

Programmable 7-day flush-mount thermostat — Thermostat offers same features as the 7-day programmable thermostat and includes locking coverplate with tamper proof screws, flush to wall mount, holiday/vacation programming, set point limiting, dual point with adjustable deadband, O or B terminal, and optional wall or duct-mounted remote sensor.

Programmable 5-day thermostat — Thermostat offers 2-stage heat, 2-stage cool, auto changeover, 5-minute built-in compressor protection, locking cover included, temperature display in degrees F or C, keypad lockout, backlit display, 5-1-1 programming, O or B terminal, dual set point with adjustable deadband, configurable display, self-prompting program, and 4 settings per day.

Non-programmable thermostat — Thermostat offers 2 heat stages, 2 cool stages, auto changeover, 5-minute built-in compressor protection, locking cover included, temperature display in degrees F or C, keypad lockout, large display, backlit display, O or B terminal, dual set point with adjustable deadband, and backplate with terminals.

UC Open XP loop controller with six stages (2 stages for heating and 4 stages for cooling) includes:

- Loop temperature alarms
- Two pump single loop flow monitoring with the ability to manually select the lead pump
- One common alarm signal and indicating light and one audible alarm

- Loop water temperature sensor test circuit
- Functional test simulation from operator keypad
- Real timeclock, industrial noise ratings
- Loop water temperature control switch

Filter rack (2 in.) is available in place of the standard 1-in. return air filter to enhance the filtration system of the water source heat pump. The 2-in. filter rack does not include filters.

Fire-rated hoses are 2 ft long and have a fixed MPT on one end and a swivel with an adapter on the other end. Hose kits are provided with both a supply and return hose and can be either stainless steel or galvanized. Two sizes are available ($3/4$ and 1 in.).

Ball valves (brass body) are used for shutoff and balancing water flow and are available with memory, memory stop, and pressure temperature ports. Ball valves consist of UL-listed brass body, ball and stem type with Teflon* seats and seals. Two sizes are available ($3/4$ and 1 in.).

Y strainers (bronze body) are "Y" type strainers with a brass cap. With a maximum operating pressure rating of 450 psi, the strainer screen is made of stainless steel and is available with blow down valves. Two sizes are available ($3/4$ and 1 in.).

Solenoid valves (brass body) offer 3.5 watt coil, 24 volt, 50/60 Hz, 740 amps inrush, .312 amps holding. Solenoid valves have slow operation for quiet system application. Two sizes are available ($3/4$ and 1 in.).

Hose kit assemblies provide all the necessary components to hook up a water-side system. Supply hose includes a ported ball valve with pressure temperature (P/T) plug ports, flexible stainless steel hose with swivel and nipple. Return hose includes a ball valve, preset automatic balancing valve (gpm) with two P/T ports, flexible stainless steel hose with a swivel and nipple, balancing valve, and low-pressure drop water control valve.

Remote sensors are available for Aquazone flush-mount thermostats and for wall (wired and wireless) or duct mounted applications.

SPT Standard offers space temperature sensor with communication port.

SPT Plus offers space temperature sensor with set point adjust, local override with indicating light and communication port.

SPT Pro offers space temperature sensor with LCD display, set point adjust, local override, alarm icon, outside air, and unit status with heating and cooling set points.

SPT Pro± offers space temperature sensor with LCD display, set point adjust, local override, alarm icon, outside air, unit status with heating and cooling set points, and fan speed control.

LON wall sensors are available in 3 models: sensor only, sensor with status override indicator, and sensor with set point, status adjustment override, and digital LCD display.

PremierLink™ accessories are available for providing a fully integrated WSHP DDC system. Accessories include supply air temperature sensors (with override and/or set point adjustment), communicating room sensors, CO₂

*Registered trademark of DuPont.

Options and accessories (cont)



sensors (for use in demand control ventilation), and linkage thermostats (to control multiple units from one thermostat).

Two-way motorized control valve can be provided for applications involving open type systems or variable speed

pumping. This valve will slowly open and close in conjunction with the compressor operation to shut off or turn on water to the unit.

AQUAZONE™ THERMOSTATS

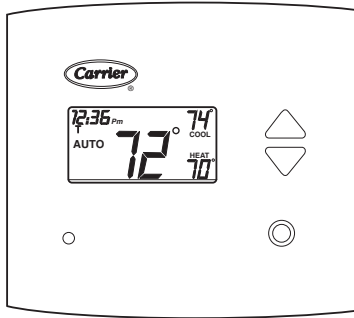

**7-DAY PROGRAMMABLE/
LIGHT-ACTIVATED PROGRAMMABLE**

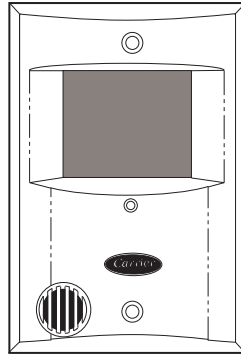

**7-DAY PROGRAMMABLE
FLUSH MOUNT**

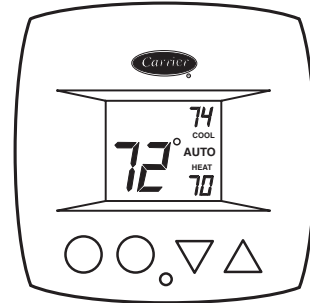

**5-DAY PROGRAMMABLE/
NON-PROGRAMMABLE**

WSHP OPEN SENSORS

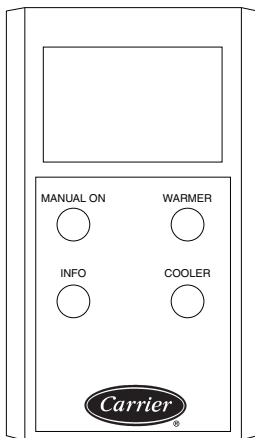

**SPACE TEMPERATURE
SENSOR WITH SET
POINT ADJUSTMENT
AND LOCAL OVERRIDE**

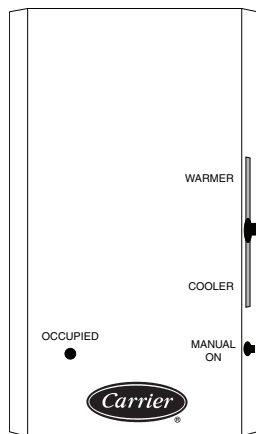

**SPACE TEMPERATURE
SENSOR WITH SLIDE SET
POINT ADJUSTMENT AND
LOCAL OVERRIDE**

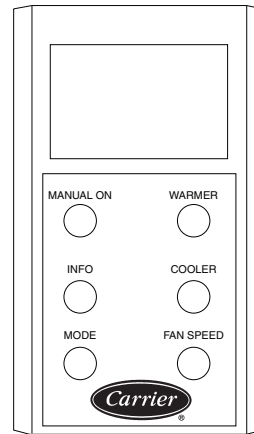

**SPACE TEMPERATURE SENSOR
WITH SET POINT ADJUSTMENT,
FAN SPEED CONTROL, AND
LOCAL OVERRIDE**

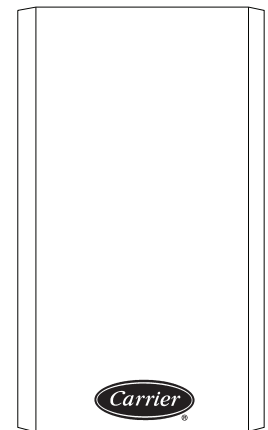

**SPACE TEMPERATURE
SENSOR ONLY**

LON WALL SENSORS

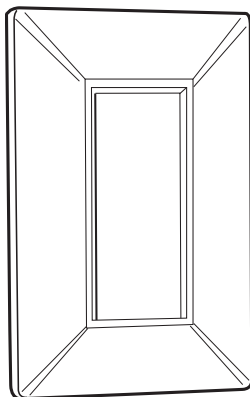

SENSOR ONLY

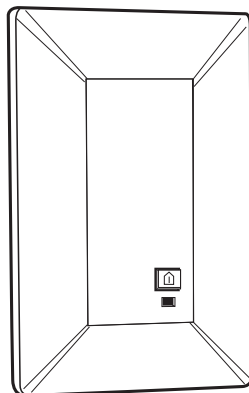

SENSOR WITH OVERRIDE

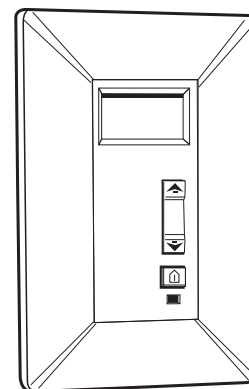

**SENSOR WITH SET POINT ADJUSTMENT,
OVERRIDE AND DIGITAL LCD**

Dimensions



50P1H006-060 UNITS

50P1H UNIT SIZE	OVERALL CABINET (in.)			WATER CONNECTIONS (in.)							ELECTRICAL KNOCKOUTS (in.)			DISCHARGE CONNECTION (in.) DUCT FLANGE INSTALLED (±0.10 in.)					RETURN CONNECTION (in.) USING RETURN AIR OPENING (±0.10 in.)			
				1 Loop		2 Loop		3 Condensate 3/4-in. FPT		Loop In/Out FPT	H 1/2	J 1/2	K 3/4	L	M Supply Height	N Supply Width	O	P	Q Return Width	R Return Height	S	T
	A Width	B Length	C Height	D In	E In	F Out	E Out	AA	BB		Low Voltage	Low Voltage	Power Supply									
006,009, 012	22.5	40.3	11.5	3.8	1.5	8.6	1.5	3.3	0.7	1/2	2.9	5.9	8.9	1.3	8.9	6.7	7.4	1.3	16.1	9.5	1.1	1.0
015,018	22.4	48.3	17.5	3.7	1.9	9.7	1.9	3.3	0.7	1/2	4.0	7.0	10.0	1.2	13.1	9.7	3.9	3.2	22.9	15.5	0.8	1.0
024,030	22.4	48.3	18.3	3.7	1.9	9.7	1.9	3.3	0.7	3/4	4.0	7.0	10.0	1.2	13.1	9.7	3.9	4.0	22.9	16.3	0.8	1.0
036,042	22.4	53.1	21.3	3.7	1.8	12.7	1.8	3.3	0.7	3/4	4.0	7.0	10.0	2.4	16.1	11.0	2.9	2.7	26.1	19.3	0.8	1.0
048,060	25.4	68.0	21.3	3.7	1.8	12.7	1.8	3.3	0.7	1	4.0	7.0	10.0	1.2	16.1	13.6	4.0	4.0	35.0	19.3	1.3	1.0

NOTES:

1. Condensate is 3/4-in. FPT copper.
2. While clear access to all removable panels is not required, installer should take care to comply with all building codes and allow adequate clearance for future field service.
3. Horizontal unit shipped with filter bracket only. This bracket should be removed for return duct connection.
4. Discharge flange and hanger kit is factory installed.
5. Blower service panel requires 2 ft of service access.
6. Blower service access is through back panel on straight discharge units or through panel opposite air coil on back discharge units.

LEGEND

- BSP — Blower Service Panel
- CAP — Control Access Panel
- CSP — Compressor Service Panel
- FPT — Female Pipe Thread

PSC BLOWER AIRFLOW CONFIGURATION

CODE	RETURN	DISCHARGE
E	Left	Back
B	Right	Back
S	Left	Right
Z	Right	Left

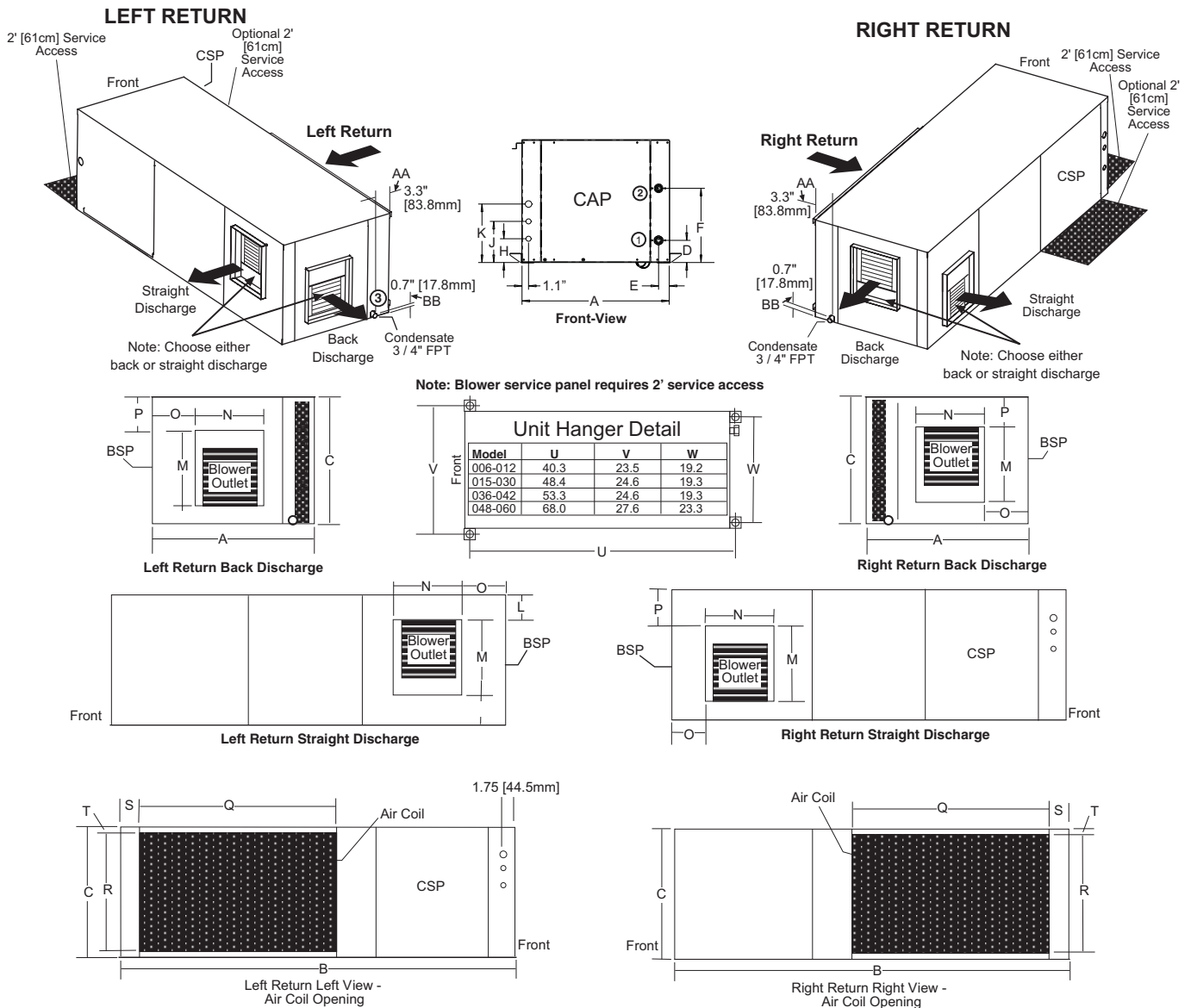

Dimensions (cont)



50P1V006-060 UNITS

50P1V UNIT SIZE	OVERALL CABINET (in.)			WATER CONNECTIONS (in.)							ELECTRICAL KNOCKOUTS (in.)			DISCHARGE CONNECTION (in.) DUCT FLANGE INSTALLED (±0.10 in.)					RETURN CONNECTION (in.) USING RETURN AIR OPENING (±0.10 in.)			
				1 Loop		2 Loop		3 Condensate 3/4-in. FPT		Loop In/Out FPT	J 1/2	K 1/2	L 3/4	M	N	O Supply Width	P Supply Depth	Q	R	S Return Depth	T Return Height	U
	A Width	B Depth	C Height	D In	E In	F Out	E Out	H	I		Low Voltage	Low Voltage	Power Supply									
006,009, 012	22.5	21.3	22.5	3.8	1.5	8.7	1.5	6.1	1.5	1/2	2.9	5.9	8.1	6.2	6.2	9.0	9.0	5.3	2.4	16.0	10.2	1.0
015,018	22.4	22.4	40.5	3.7	1.9	9.7	1.9	7.0	1.9	1/2	4.0	7.0	10.0	7.2	4.2	14.0	14.0	6.7	2.2	18.4	20.3	1.1
024,030	22.4	22.4	40.5	3.7	1.9	9.7	1.9	7.0	1.9	3/4	4.0	7.0	10.0	7.2	4.2	14.0	14.0	6.7	2.2	18.4	20.3	1.1
036,042	22.4	25.4	46.5	3.7	1.8	12.7	1.8	8.0	1.8	3/4	4.0	7.0	10.0	7.2	6.0	14.0	14.0	6.5	2.1	22.9	24.3	1.1
048,060	25.4	29.1	50.5	3.7	1.8	12.7	1.8	8.0	1.8	1	4.0	7.0	10.0	8.2	5.7	16.0	18.0	7.3	2.1	26.2	28.3	1.1

NOTES:

1. Condensate is 3/4-in. FPT.
2. While clear access to all removable panels is not required, installer should take care to comply with all building codes and allow adequate clearance for future field service.
3. Front and side access is preferred for service access. However, all components may be serviced from the front access panel if side access is not available.
4. Discharge flange is field installed.

LEGEND

- ASP — Alternate Service Panel
- BSP — Blower Service Panel
- CAP — Control Access Panel
- CSP — Compressor Service Panel
- FPT — Female Pipe Thread
- HV — High Voltage
- LV — Low Voltage

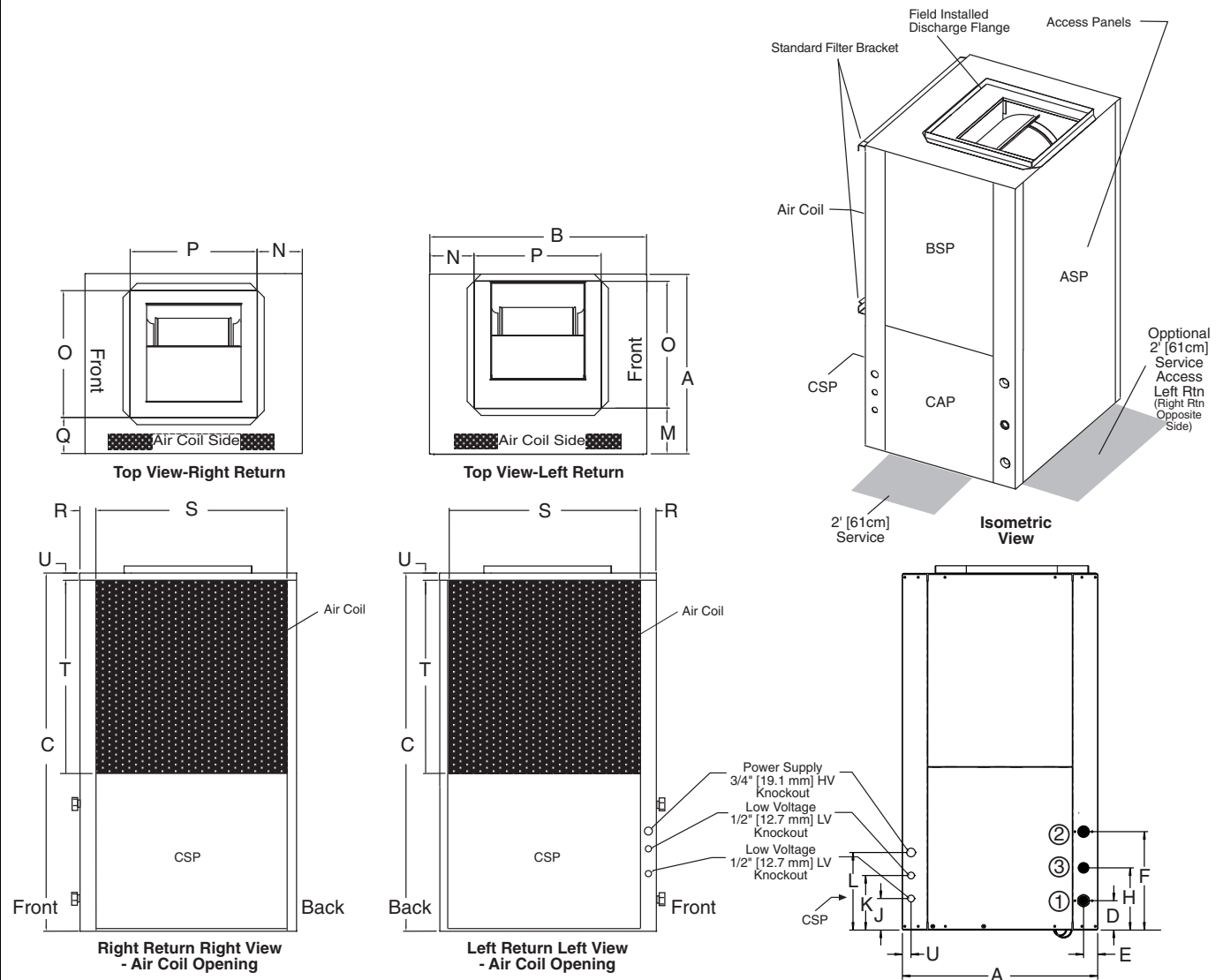

Selection procedure (50P1H024 unit example)



I Determine the actual cooling and heating loads at the desired dry bulb and wet bulb conditions.

Given:

Total Cooling (TC) 24,500 Btuh
 Sensible Cooling (SC) 21,800 Btuh
 Entering-Air Temperature db 80.0 F
 Entering-Air Temperature wb 65 F

II Determine the following design parameters from Performance Data tables.

Determine entering water temperature, water flow rate (gpm), airflow (cfm), water flow pressure drop and design wet and dry bulb temperatures. Airflow cfm should be between 300 and 450 cfm per ton. Unit water pressure drop should be kept as close as possible to each other to make water balancing easier. For the 50P1H024 unit example, the given design parameters are as follows:

Given:

Entering Water Temperature 90 F
 Water Flow (Based upon
 12 F rise in temperature) 6.0 gpm
 Airflow 750 cfm

III Select a unit based on total cooling and total sensible cooling conditions. Unit selected should be closest to but not larger than the actual cooling load.

Enter Performance Data tables at the design water flow and water temperature. Read the total and sensible cooling capacities.

NOTE: Interpolation is permissible, extrapolation is not.

For example, enter the 50P1H024 (PSC Blower) Performance Table at design water flow and water temperature. Read Total Cooling, Sensible Cooling and Heat of Rejection capacities:

Total Cooling 23,400 Btuh
 Sensible Cooling 17,500 Btuh
 Heat of Rejection 30,200 Btuh

Read the Heat Capacity. If the Heat Capacity exceeds the design criteria specified in the scope, it is acceptable.

NOTE: It is normal for water source heat pumps to be selected on cooling capacity only since the heating output is usually greater than the cooling capacity.

IV Determine the correction factors associated with the variable factors of dry bulb and wet bulb using the correction factor tables found in this book.

Use the following formulas to determine the correction factors of total cooling, sensible cooling, and heat of rejection:

- Corrected Total Cooling = tabulated total cooling x wet bulb correction x airflow correction.
- Corrected Sensible Cooling = tabulated sensible cooling x wet/dry bulb correction x airflow correction.

- Corrected Heat of Rejection = tabulated heat of rejection x wet bulb correction x airflow correction.

V Determine entering air and airflow correction using the correction factor tables found in this book.

The nominal airflow for the 50P1H024 is 800 cfm. The design parameter is 750 cfm. Actual airflow (from table) is 850 cfm.

$$750/850 \times 100 = 88\% \text{ of actual airflow:}$$

Use the 87.5% row in the Airflow Correction Table.

The Entering-Air Temperature is 65 F wb. Use the 65 F row in the Entering Air Correction Table.

Using the following formulas to determine the correction factors of entering air and airflow correction:

	Table	Ent Air	Airflow	Corrected
Corrected Total Cooling	=	23,400	x 0.9681	x 0.9889 = 22,402
Corrected Sensible Cooling	=	17,500	x 1.1213	x 1.0484 = 20,572
Corrected Heat of Rejection	=	30,200	x 0.9747	x 0.9393 = 27,649

Compare the corrected capacities to the load requirements established in Step I. If the capacities are within 10% of the load requirements, the equipment is acceptable. It is better to undersize than oversize as undersizing improves humidity control, reduces sound levels and extends the life of the equipment.

VI Calculate and assess the water temperature rise.

Calculate the water temperature rise and assess the selection using the following calculation:

$$\text{Actual Temperature Rise} = \frac{\text{Corrected Heat of Rejection}}{\text{GPM} \times 500}$$

For example, using the Corrected Heat of Rejection from the last step:

$$\text{Actual Temperature Rise} = \frac{27,649}{6.0 \times 500} = 9.2 \text{ F}$$

If the units selected are not within 10% of the load calculations, review what effect changing the GPM, water temperature and/or airflow will have on the corrected capacities. If the desired capacity cannot be achieved, select the next larger or smaller unit and repeat Steps I through VI.

ADDITIONAL REFERENCE CALCULATIONS

HEATING

$$\text{LWT} = \text{EWT} - (\text{HE} / \text{GPM} \times 500)$$

$$\text{LAT} = \text{EAT} + (\text{HC} / \text{CFM} \times 1.08)$$

COOLING

$$\text{LWT} = \text{EWT} + (\text{HR} / \text{GPM} \times 500)$$

$$\text{LAT (db)} = \text{EAT (db)} - (\text{SC} / \text{CFM} \times 1.08)$$

$$\text{Latent Cooling (LC)} = \text{Total Cooling (TC)} - \text{Sensible Cooling (SC)}$$

Performance data



50P1H,P1V006

220 CFM NOMINAL AIRFLOW COOLING/220 CFM NOMINAL AIRFLOW HEATING*

EWT (F)	GPM	PRESSURE DROP		COOLING — EAT 80/67 F							HEATING — EAT 70 F					
		PSI	ft wg	Airflow CFM	TC	TSC	Sens/Tot Ratio	kW	THR	EER	Airflow CFM	THC	kW	HE	LAT	COP
20	1.5	1.7	4.0	Operation Not Recommended							170	4.3	0.49	2.7	93.3	2.6
	1.5	1.7	4.0	Operation Not Recommended							225	4.4	0.44	2.9	88.0	2.9
30	0.8	0.5	1.2	170	7.4	4.2	0.57	0.28	8.4	26.4	170	4.6	0.50	3.0	95.2	2.7
	0.8	0.5	1.2	225	7.7	4.8	0.62	0.29	8.7	26.4	225	4.7	0.45	3.2	89.5	3.1
	1.1	0.8	1.8	170	7.4	4.1	0.55	0.26	8.3	28.5	170	4.8	0.51	3.2	96.2	2.8
	1.1	0.8	1.8	225	7.7	4.6	0.60	0.27	8.6	28.5	225	4.9	0.46	3.4	90.3	3.2
	1.5	1.3	2.9	170	7.3	4.0	0.54	0.25	8.2	29.2	170	4.9	0.51	3.2	96.8	2.8
	1.5	1.3	2.9	225	7.6	4.5	0.59	0.26	8.5	29.2	225	5.0	0.46	3.5	90.7	3.2
40	0.8	0.4	0.9	170	7.3	4.3	0.59	0.31	8.3	23.2	170	5.3	0.52	3.6	98.8	3.0
	0.8	0.4	0.9	225	7.6	4.8	0.64	0.33	8.7	23.2	225	5.4	0.47	3.8	92.3	3.4
	1.1	0.6	1.4	170	7.4	4.2	0.57	0.29	8.4	25.8	170	5.5	0.53	3.8	100.2	3.1
	1.1	0.6	1.4	225	7.7	4.8	0.62	0.30	8.7	25.8	225	5.7	0.47	4.1	93.3	3.5
	1.5	1.0	2.4	170	7.4	4.2	0.56	0.28	8.4	26.9	170	5.7	0.53	3.9	100.9	3.1
	1.5	1.0	2.4	225	7.7	4.7	0.61	0.29	8.7	26.9	225	5.8	0.48	4.2	93.9	3.6
50	0.8	0.3	0.8	170	6.9	4.2	0.61	0.35	8.1	19.9	170	6.0	0.54	4.2	102.7	3.3
	0.8	0.3	0.8	225	7.2	4.8	0.66	0.36	8.5	19.9	225	6.1	0.48	4.5	95.3	3.7
	1.1	0.5	1.2	170	7.2	4.3	0.59	0.32	8.3	22.5	170	6.3	0.55	4.5	104.4	3.4
	1.1	0.5	1.2	225	7.5	4.8	0.64	0.33	8.6	22.5	225	6.5	0.49	4.8	96.6	3.9
	1.5	0.9	2.0	170	7.3	4.3	0.58	0.31	8.3	23.8	170	6.5	0.55	4.6	105.4	3.4
	1.5	0.9	2.0	225	7.6	4.8	0.63	0.32	8.7	23.8	225	6.7	0.50	5.0	97.4	3.9
60	0.8	0.3	0.6	170	6.5	4.1	0.63	0.39	7.9	16.8	170	6.7	0.56	4.9	106.7	3.5
	0.8	0.3	0.6	225	6.8	4.7	0.69	0.40	8.2	16.8	225	6.9	0.50	5.2	98.4	4.0
	1.1	0.5	1.0	170	6.9	4.2	0.61	0.36	8.1	19.1	170	7.1	0.57	5.2	108.6	3.7
	1.1	0.5	1.0	225	7.1	4.8	0.67	0.37	8.4	19.1	225	7.3	0.51	5.5	99.9	4.2
	1.5	0.8	1.8	170	7.0	4.2	0.61	0.34	8.2	20.4	170	7.3	0.57	5.3	109.7	3.7
	1.5	0.8	1.8	225	7.3	4.8	0.66	0.36	8.5	20.4	225	7.5	0.51	5.7	100.7	4.3
70	0.8	0.2	0.5	170	6.0	4.0	0.66	0.43	7.5	14.0	170	7.4	0.58	5.5	110.5	3.8
	0.8	0.2	0.5	225	6.3	4.5	0.72	0.45	7.8	14.0	225	7.6	0.52	5.9	101.4	4.3
	1.1	0.4	0.9	170	6.4	4.1	0.64	0.40	7.8	16.0	170	7.8	0.58	5.8	112.4	3.9
	1.1	0.4	0.9	225	6.7	4.6	0.70	0.42	8.1	16.0	225	8.0	0.53	6.2	102.8	4.5
	1.5	0.7	1.6	170	6.6	4.1	0.63	0.38	7.9	17.1	170	8.0	0.59	5.9	113.4	4.0
	1.5	0.7	1.6	225	6.8	4.7	0.69	0.40	8.2	17.1	225	8.2	0.53	6.4	103.6	4.5
80	0.8	0.2	0.5	170	5.6	3.8	0.68	0.47	7.2	12.0	170	7.9	0.59	5.9	113.2	4.0
	0.8	0.2	0.5	225	5.8	4.3	0.74	0.49	7.5	12.0	225	8.1	0.53	6.3	103.5	4.5
	1.1	0.4	0.8	170	5.9	3.9	0.67	0.45	7.4	13.2	170	8.3	0.60	6.3	115.4	4.1
	1.1	0.4	0.8	225	6.1	4.4	0.73	0.46	7.7	13.2	225	8.5	0.54	6.7	105.1	4.6
	1.5	0.6	1.5	170	6.2	4.0	0.65	0.42	7.6	14.7	170	8.4	0.60	6.3	115.7	4.1
	1.5	0.6	1.5	225	6.4	4.6	0.71	0.44	7.9	14.7	225	8.6	0.54	6.7	105.3	4.6
85	0.8	0.2	0.5	170	5.3	3.7	0.70	0.50	7.0	10.7	170	8.2	0.60	6.2	114.7	4.0
	0.8	0.2	0.5	225	5.5	4.2	0.76	0.52	7.3	10.7	225	8.4	0.50	6.6	104.6	4.6
	1.1	0.3	0.8	170	5.6	3.8	0.68	0.47	7.2	11.9	170	8.5	0.60	6.4	116.2	4.1
	1.1	0.3	0.8	225	5.8	4.3	0.74	0.49	7.5	11.9	225	8.7	0.50	6.8	105.8	4.7
	1.5	0.6	1.4	170	5.8	3.9	0.67	0.45	7.4	13.1	170	8.5	0.60	6.4	116.4	4.1
	1.5	0.6	1.4	225	6.1	4.4	0.73	0.47	7.7	13.1	225	8.7	0.50	6.8	105.9	4.7
90	0.8	0.2	0.4	170	5.0	3.6	0.72	0.53	6.7	9.4	170	8.5	0.61	6.4	116.3	4.1
	0.8	0.2	0.4	225	5.2	4.1	0.79	0.55	7.0	9.4	225	8.7	0.55	6.8	105.8	4.7
	1.1	0.3	0.7	170	5.3	3.7	0.70	0.49	7.0	10.7	170	8.6	0.62	6.5	117.0	4.1
	1.1	0.3	0.7	225	5.5	4.2	0.76	0.52	7.3	10.7	225	8.8	0.55	7.0	106.4	4.7
	1.5	0.6	1.3	170	5.5	3.8	0.69	0.48	7.1	11.5	170	8.7	0.62	6.5	117.1	4.1
	1.5	0.6	1.3	225	5.7	4.3	0.75	0.50	7.4	11.5	225	8.9	0.56	7.0	106.5	4.7
100	0.8	0.2	0.4	170	4.4	3.4	0.76	0.58	6.4	7.6	Operation Not Recommended					
	0.8	0.2	0.4	225	4.6	3.8	0.83	0.60	6.6	7.6						
	1.1	0.3	0.7	170	4.7	3.5	0.74	0.55	6.6	8.7						
	1.1	0.3	0.7	225	4.9	4.0	0.80	0.57	6.9	8.7						
	1.5	0.5	1.2	170	4.9	3.6	0.73	0.53	6.7	9.3						
	1.5	0.5	1.2	225	5.1	4.0	0.79	0.55	7.0	9.3						
110	0.8	0.2	0.3	170	3.9	3.1	0.81	0.63	6.0	6.2						
	0.8	0.2	0.3	225	4.1	3.6	0.87	0.66	6.3	6.2						
	1.1	0.3	0.6	170	4.2	3.3	0.78	0.6	6.2	7.0						
	1.1	0.3	0.6	225	4.4	3.7	0.85	0.62	6.5	7.0						
	1.5	0.5	1.2	170	4.3	3.3	0.77	0.58	6.3	7.4						
	1.5	0.5	1.2	225	4.5	3.8	0.83	0.61	6.6	7.4						
120	0.8	0.1	0.3	170	3.5	3.0	0.85	0.68	5.8	5.0						
	0.8	0.1	0.3	225	3.6	3.3	0.93	0.71	6.0	5.0						
	1.1	0.3	0.6	170	3.7	3.0	0.83	0.65	5.9	5.6						
	1.1	0.3	0.6	225	3.8	3.4	0.90	0.68	6.2	5.6						
	1.5	0.5	1.1	170	3.8	3.1	0.81	0.64	6.0	6.0						
	1.5	0.5	1.1	225	4.0	3.5	0.88	0.67	6.2	6.0						

LEGEND

- AHRI — Air Conditioning, Heating, and Refrigeration Institute
- COP — Coefficient of Performance
- db — Dry Bulb
- EAT — Entering Air Temperature
- EER — Energy Efficiency Ratio
- EWT — Entering Water Temperature
- GPM — Gallons Per Minute
- HE — Heat of Extraction (MBtuh)
- ISO — International Organization for Standardization
- LAT — Leaving Air Temperature (F)
- MBtuh — Btuh in Thousands
- TC — Total Capacity (MBtuh)
- THC — Total Heating Capacity (MBtuh)
- THR — Total Heat Rejection (MBtuh)
- TSC — Total Sensible Capacity (MBtuh)
- wb — Wet Bulb

*Performance capacities shown in thousands of Btuh.

NOTES:

1. Interpolation is permissible; extrapolation is not.
2. All entering air conditions are 80 F db and 67 F wb in cooling, and 70 F db in heating. AHRI/ISO certified conditions are 80.6 F db and 66.2 F wb in cooling and 68 F db in heating.
3. Table does not reflect fan or pump power corrections for AHRI/ISO conditions.
4. All performance is based upon the lower voltage of dual voltage rated units.
5. Operation below 40 F EWT is based upon a 15% methanol antifreeze solution.
6. Operation below 60 F EWT requires optional insulated water/refrigerant circuit.
7. See performance correction tables for operating conditions other than those listed above.



50P1H,P1V009

325 CFM NOMINAL AIRFLOW COOLING/325 CFM NOMINAL AIRFLOW HEATING*

EWT (F)	GPM	PRESSURE DROP		COOLING — EAT 80/67 F							HEATING — EAT 70 F					
		PSI	ft wg	Airflow CFM	TC	TSC	Sens/Tot Ratio	kW	THR	EER	Airflow CFM	THC	kW	HE	LAT	COP
20	2.3	4.5	10.5	Operation Not Recommended							250	6.5	0.73	4.2	94.2	2.6
	2.3	4.5	10.5	Operation Not Recommended							330	6.7	0.66	4.4	88.8	3.0
30	1.1	1.3	3.0	250	10.2	6.0	0.59	0.39	11.6	26.6	250	7.1	0.74	4.7	96.3	2.8
	1.1	1.3	3.0	330	10.7	6.8	0.64	0.40	12.0	26.6	330	7.3	0.67	5.0	90.4	3.2
	1.7	1.9	4.4	250	10.5	6.0	0.57	0.36	11.7	29.5	250	7.4	0.75	4.9	97.4	2.9
	1.7	1.9	4.4	330	10.9	6.8	0.62	0.37	12.2	29.5	330	7.6	0.67	5.3	91.2	3.3
	2.3	3.5	8.1	250	10.6	6.0	0.56	0.34	11.8	31.1	250	7.5	0.75	5.1	97.9	2.9
	2.3	3.5	8.1	330	11.0	6.8	0.61	0.36	12.3	31.1	330	7.7	0.68	5.4	91.7	3.4
40	1.1	0.9	2.0	250	9.9	6.0	0.61	0.43	11.3	22.8	250	8.0	0.76	5.5	99.8	3.1
	1.1	0.9	2.0	330	10.3	6.8	0.66	0.45	11.8	22.8	330	8.2	0.69	5.9	93.1	3.5
	1.7	1.5	3.5	250	10.1	6.0	0.59	0.40	11.5	25.4	250	8.4	0.77	5.8	101.1	3.2
	1.7	1.5	3.5	330	10.5	6.8	0.64	0.41	12.0	25.4	330	8.6	0.69	6.2	94.1	3.6
	2.3	3.0	6.8	250	10.3	6.0	0.59	0.38	11.6	26.8	250	8.6	0.78	6.0	101.8	3.2
	2.3	3.0	6.8	330	10.7	6.8	0.64	0.40	12.0	26.9	330	8.8	0.70	6.4	94.7	3.7
50	1.1	0.6	1.5	250	9.4	6.0	0.63	0.48	11.1	19.5	250	9.0	0.79	6.4	103.3	3.4
	1.1	0.6	1.5	330	9.8	6.7	0.69	0.50	11.6	19.5	330	9.2	0.71	6.8	95.8	3.8
	1.7	1.3	2.9	250	9.7	6.0	0.62	0.45	11.3	21.7	250	9.4	0.80	6.7	104.8	3.5
	1.7	1.3	2.9	330	10.1	6.8	0.67	0.47	11.7	21.7	330	9.6	0.72	7.2	97.0	3.9
	2.3	2.6	6.0	250	9.9	6.0	0.61	0.43	11.3	23.0	250	9.6	0.80	6.9	105.6	3.5
	2.3	2.6	6.0	330	10.3	6.8	0.66	0.45	11.8	23.0	330	9.8	0.72	7.4	97.6	4.0
60	1.1	0.5	1.2	250	9.0	5.9	0.65	0.54	10.8	16.5	250	9.9	0.81	7.2	106.8	3.6
	1.1	0.5	1.2	330	9.4	6.7	0.71	0.57	11.3	16.5	330	10.2	0.73	7.7	98.5	4.1
	1.7	1.1	2.5	250	9.3	5.9	0.64	0.50	11.0	18.5	250	10.4	0.82	7.6	108.4	3.7
	1.7	1.1	2.5	330	9.7	6.7	0.69	0.52	11.5	18.5	330	10.6	0.74	8.1	99.8	4.2
	2.3	2.3	5.4	250	9.5	6.0	0.63	0.48	11.1	19.6	250	10.6	0.83	7.8	109.3	3.7
	2.3	2.3	5.4	330	9.8	6.7	0.69	0.50	11.6	19.6	330	10.9	0.75	8.3	100.5	4.3
70	1.1	0.4	0.9	250	8.5	5.8	0.68	0.61	10.6	14.0	250	10.8	0.84	8.0	110.1	3.8
	1.1	0.4	0.9	330	8.8	6.5	0.74	0.63	11.0	14.0	330	11.1	0.75	8.5	101.1	4.3
	1.7	1.0	2.3	250	8.8	5.8	0.66	0.56	10.7	15.6	250	11.3	0.85	8.4	111.9	3.9
	1.7	1.0	2.3	330	9.2	6.6	0.72	0.59	11.2	15.6	330	11.6	0.77	9.0	102.5	4.4
	2.3	2.1	4.9	250	9.1	5.9	0.65	0.53	10.9	17.1	250	11.4	0.85	8.5	112.1	3.9
	2.3	2.1	4.9	330	9.5	6.7	0.71	0.55	11.3	17.1	330	11.6	0.77	9.0	102.7	4.4
80	1.1	0.3	0.8	250	8.0	5.6	0.70	0.67	10.3	11.8	250	11.7	0.87	8.7	113.3	4.0
	1.1	0.3	0.8	330	8.3	6.3	0.77	0.70	10.7	11.8	330	12.0	0.78	9.3	103.6	4.5
	1.7	0.9	2.1	250	8.3	5.7	0.69	0.63	10.5	13.2	250	12.2	0.88	9.1	115.1	4.0
	1.7	0.9	2.1	330	8.6	6.5	0.75	0.66	10.9	13.2	330	12.5	0.79	9.8	105.0	4.6
	2.3	2.0	4.6	250	8.6	5.8	0.67	0.59	10.6	14.4	250	12.2	0.88	9.2	115.4	4.1
	2.3	2.0	4.6	330	8.9	6.5	0.73	0.62	11.1	14.4	330	12.5	0.79	9.8	105.2	4.6
85	1.1	0.3	0.7	250	7.7	5.5	0.71	0.70	10.1	11.0	250	12.0	0.88	9.0	114.5	4.0
	1.1	0.3	0.7	330	8.0	6.2	0.78	0.73	10.5	11.0	330	12.3	0.80	9.6	104.6	4.6
	1.7	0.9	2.0	250	8.0	5.6	0.70	0.67	10.3	12.1	250	12.6	0.90	9.5	116.5	4.1
	1.7	0.9	2.0	330	8.4	6.4	0.76	0.69	10.7	12.1	330	12.9	0.80	10.1	106.1	4.7
	2.3	1.9	4.4	250	8.3	5.7	0.69	0.63	10.5	13.3	250	12.6	0.90	9.5	116.8	4.1
	2.3	1.9	4.4	330	8.7	6.5	0.75	0.65	10.9	13.3	330	12.9	0.80	10.2	106.3	4.7
90	1.1	0.3	0.6	250	7.5	5.4	0.72	0.73	10.0	10.2	250	12.3	0.89	9.3	115.7	4.1
	1.1	0.3	0.6	330	7.8	6.2	0.79	0.76	10.4	10.2	330	12.6	0.80	9.9	105.5	4.6
	1.7	0.8	1.9	250	7.7	5.5	0.71	0.70	10.1	11.1	250	12.9	0.91	9.8	117.9	4.2
	1.7	0.8	1.9	330	8.1	6.3	0.78	0.73	10.6	11.1	330	13.3	0.82	10.5	107.2	4.8
	2.3	1.8	4.3	250	8.0	5.6	0.70	0.66	10.3	12.1	250	13.0	0.91	9.9	118.2	4.2
	2.3	1.8	4.3	330	8.4	6.4	0.76	0.69	10.7	12.1	330	13.3	0.82	10.5	107.4	4.8
100	1.1	0.2	0.6	250	6.8	5.1	0.76	0.82	9.6	8.2	Operation Not Recommended					
	1.1	0.2	0.6	330	7.0	5.8	0.82	0.86	10.0	8.2						
	1.7	0.8	1.7	250	7.1	5.3	0.74	0.78	9.8	9.2						
	1.7	0.8	1.7	330	7.4	6.0	0.81	0.81	10.2	9.2						
	2.3	1.7	4.0	250	7.3	5.4	0.73	0.75	9.9	9.7						
	2.3	1.7	4.0	330	7.6	6.1	0.80	0.78	10.3	9.7						
110	1.1	0.2	0.5	250	6.1	4.8	0.79	0.90	9.2	6.8						
	1.1	0.2	0.5	330	6.3	5.4	0.85	0.94	9.5	6.8						
	1.7	0.7	1.6	250	6.5	5.0	0.77	0.86	9.4	7.6						
	1.7	0.7	1.6	330	6.8	5.6	0.84	0.89	9.8	7.6						
	2.3	1.6	3.8	250	6.7	5.1	0.76	0.83	9.5	8.0						
	2.3	1.6	3.8	330	7.0	5.8	0.83	0.87	9.9	8.0						
120	1.1	0.2	0.4	250	5.4	4.4	0.82	0.98	8.7	5.5						
	1.1	0.2	0.4	330	5.6	5.0	0.89	1.02	9.1	5.5						
	1.7	0.7	1.6	250	5.8	4.6	0.80	0.94	9.0	6.2						
	1.7	0.7	1.6	330	6.0	5.2	0.87	0.98	9.4	6.2						
	2.3	1.6	3.6	250	6.0	4.7	0.79	0.91	9.1	6.5						
	2.3	1.6	3.6	330	6.2	5.4	0.86	0.95	9.5	6.5						

LEGEND

- AHRI — Air Conditioning, Heating, and Refrigeration Institute
- COP — Coefficient of Performance
- db — Dry Bulb
- EAT — Entering Air Temperature
- EER — Energy Efficiency Ratio
- EWT — Entering Water Temperature
- GPM — Gallons Per Minute
- HE — Heat of Extraction (MBtuh)
- ISO — International Organization for Standardization
- LAT — Leaving Air Temperature (F)
- MBtuh — Btuh in Thousands
- TC — Total Capacity (MBtuh)
- THC — Total Heating Capacity (MBtuh)
- THR — Total Heat Rejection (MBtuh)
- TSC — Total Sensible Capacity (MBtuh)
- wb — Wet Bulb

*Performance capacities shown in thousands of Btuh.

NOTES:

1. Interpolation is permissible; extrapolation is not.
2. All entering air conditions are 80 F db and 67 F wb in cooling, and 70 F db in heating. AHRI/ISO certified conditions are 80.6 F db and 66.2 F wb in cooling and 68 F db in heating.
3. Table does not reflect fan or pump power corrections for AHRI/ISO conditions.
4. All performance is based upon the lower voltage of dual voltage rated units.
5. Operation below 40 F EWT is based upon a 15% methanol antifreeze solution.
6. Operation below 60 F EWT requires optional insulated water/refrigerant circuit.
7. See performance correction tables for operating conditions other than those listed above.

Performance data (cont)



50P1H,P1V012

400 CFM NOMINAL AIRFLOW COOLING/400 CFM NOMINAL AIRFLOW HEATING*

EWT (F)	GPM	PRESSURE DROP		COOLING — EAT 80/67 F							HEATING — EAT 70 F					
		PSI	ft wg	Airflow CFM	TC	TSC	Sens/Tot Ratio	kW	THR	EER	Airflow CFM	THC	kW	HE	LAT	COP
20	3.0	8.5	19.6	Operation Not Recommended							300	8.5	0.98	5.3	96.20	2.5
	3.0	8.5	19.6	Operation Not Recommended							400	8.7	0.88	5.7	90.20	2.9
30	1.5	1.9	4.3	300	14.2	8.2	0.58	0.55	16.1	25.8	300	9.3	1.00	6.0	98.6	2.7
	1.5	1.9	4.3	400	14.8	9.3	0.63	0.57	16.8	25.8	400	9.5	0.90	6.4	91.9	3.1
	2.3	3.6	8.4	300	14.3	8.2	0.58	0.51	16.1	27.9	300	9.6	1.01	6.3	99.7	2.8
	2.3	3.6	8.4	400	14.9	9.3	0.63	0.53	16.7	27.9	400	9.9	0.91	6.8	92.8	3.2
	3.0	6.7	15.5	300	14.3	8.2	0.58	0.50	16.0	28.8	300	9.8	1.02	6.5	100.4	2.8
	3.0	6.7	15.5	400	14.9	9.3	0.63	0.52	16.6	28.8	400	10.1	0.92	7.0	93.3	3.2
40	1.5	1.4	3.2	300	14.0	8.1	0.58	0.61	16.0	22.9	300	10.6	1.04	7.1	102.6	3.0
	1.5	1.4	3.2	400	14.5	9.2	0.63	0.63	16.7	22.9	400	10.8	0.93	7.6	95.0	3.4
	2.3	3.0	6.9	300	14.2	8.2	0.58	0.57	16.1	25.1	300	11.0	1.05	7.6	104.1	3.1
	2.3	3.0	6.9	400	14.8	9.3	0.63	0.59	16.8	25.1	400	11.3	0.94	8.1	96.2	3.5
	3.0	5.7	13.1	300	14.3	8.2	0.58	0.54	16.1	26.2	300	11.3	1.06	7.8	104.9	3.1
	3.0	5.7	13.1	400	14.8	9.3	0.63	0.57	16.8	26.2	400	11.6	0.95	8.3	96.8	3.6
50	1.5	1.1	2.5	300	13.5	7.9	0.58	0.67	15.8	20.1	300	11.9	1.08	8.3	106.8	3.2
	1.5	1.1	2.5	400	14.1	8.9	0.63	0.70	16.5	20.1	400	12.2	0.97	8.9	98.2	3.7
	2.3	2.6	6.0	300	13.9	8.0	0.58	0.62	16.0	22.2	300	12.5	1.09	8.9	108.6	3.4
	2.3	2.6	6.0	400	14.4	9.1	0.63	0.65	16.7	22.2	400	12.8	0.98	9.5	99.6	3.8
	3.0	5.0	11.5	300	14.0	8.1	0.58	0.60	16.1	23.3	300	12.8	1.10	9.1	109.6	3.4
	3.0	5.0	11.5	400	14.6	9.2	0.63	0.63	16.7	23.3	400	13.1	0.99	9.8	100.4	3.9
60	1.5	0.9	2.1	300	12.9	7.6	0.59	0.74	15.5	17.4	300	13.3	1.11	9.6	111.1	3.5
	1.5	0.9	2.1	400	13.5	8.6	0.64	0.77	16.1	17.4	400	13.6	1.00	10.2	101.5	4.0
	2.3	2.3	5.3	300	13.4	7.8	0.58	0.69	15.7	19.3	300	14.0	1.13	10.2	113.1	3.6
	2.3	2.3	5.3	400	13.9	8.8	0.63	0.72	16.4	19.3	400	14.3	1.02	10.8	103.1	4.1
	3.0	4.5	10.3	300	13.6	7.9	0.58	0.67	15.8	20.4	300	14.3	1.14	10.5	114.2	3.7
	3.0	4.5	10.3	400	14.1	8.9	0.63	0.69	16.5	20.4	400	14.7	1.03	11.2	104.0	4.2
70	1.5	0.8	1.8	300	12.2	7.3	0.60	0.82	15.0	14.9	300	14.7	1.15	10.8	115.3	3.7
	1.5	0.8	1.8	400	12.7	8.3	0.65	0.85	15.6	14.9	400	15.0	1.04	11.5	104.8	4.2
	2.3	2.1	4.8	300	12.5	7.4	0.59	0.77	15.2	16.3	300	15.4	1.18	11.4	117.6	3.8
	2.3	2.1	4.8	400	13.1	8.4	0.64	0.80	15.8	16.3	400	15.8	1.06	12.2	106.5	4.4
	3.0	4.1	9.5	300	12.7	7.5	0.59	0.75	15.3	17.0	300	15.8	1.19	11.7	118.8	3.9
	3.0	4.1	9.5	400	13.3	8.5	0.64	0.78	15.9	17.0	400	16.2	1.07	12.5	107.5	4.4
80	1.5	0.7	1.5	300	11.4	7.0	0.61	0.90	14.5	12.7	300	16.0	1.20	11.9	119.4	3.9
	1.5	0.7	1.5	400	11.9	7.9	0.67	0.94	15.1	12.7	400	16.4	1.08	12.7	108.0	4.5
	2.3	1.9	4.4	300	11.8	7.1	0.60	0.85	14.7	13.9	300	16.8	1.22	12.6	121.7	4.0
	2.3	1.9	4.4	400	12.3	8.0	0.65	0.88	15.3	13.9	400	17.2	1.10	13.4	109.8	4.6
	3.0	3.8	8.8	300	12.0	7.2	0.60	0.83	14.8	14.5	300	17.2	1.24	12.9	123.0	4.1
	3.0	3.8	8.8	400	12.5	8.1	0.65	0.86	15.4	14.5	400	17.6	1.11	13.8	110.7	4.6
85	1.5	0.6	1.5	300	10.9	6.8	0.62	0.90	14.2	11.7	300	16.6	1.22	12.5	121.3	4.0
	1.5	0.6	1.5	400	11.4	7.7	0.68	0.98	14.7	11.7	400	17.0	1.10	13.3	109.4	4.6
	2.3	1.8	4.2	300	11.4	6.9	0.61	0.89	14.4	12.8	300	17.4	1.30	13.1	123.6	4.1
	2.3	1.8	4.2	400	11.9	7.9	0.66	0.93	15.0	12.8	400	17.8	1.10	14.0	111.2	4.6
	3.0	3.7	8.5	300	11.6	7.0	0.60	0.87	14.5	13.4	300	17.7	1.30	13.4	124.8	4.1
	3.0	3.7	8.5	400	12.1	7.9	0.66	0.90	15.1	13.4	400	18.2	1.10	14.3	112.1	4.7
90	1.5	0.6	1.4	300	10.5	6.7	0.63	0.99	13.9	10.7	300	17.3	1.24	13.0	123.3	4.1
	1.5	0.6	1.4	400	10.9	7.5	0.69	1.03	14.4	10.7	400	17.7	1.12	13.9	110.9	4.6
	2.3	1.8	4.1	300	11.0	6.8	0.62	0.93	14.1	11.7	300	18.0	1.28	13.6	125.5	4.1
	2.3	1.8	4.1	400	11.4	7.7	0.67	0.97	14.7	11.7	400	18.4	1.15	14.5	112.6	4.7
	3.0	3.6	8.2	300	11.2	6.8	0.61	0.91	14.3	12.3	300	18.3	1.29	13.9	126.6	4.2
	3.0	3.6	8.2	400	11.6	7.7	0.67	0.95	14.8	12.3	400	18.8	1.16	14.8	113.5	4.7
100	1.5	0.5	1.2	300	9.5	6.4	0.67	1.07	13.2	8.9	Operation Not Recommended					
	1.5	0.5	1.2	400	9.9	7.2	0.72	1.12	13.8	8.9						
	2.3	1.7	3.8	300	10.1	6.5	0.65	1.02	13.5	9.8						
	2.3	1.7	3.8	400	10.5	7.3	0.70	1.06	14.1	9.8						
	3.0	3.3	7.7	300	10.4	6.6	0.64	1.00	13.8	10.4						
	3.0	3.3	7.7	400	10.8	7.5	0.69	1.04	14.3	10.4						
110	1.5	0.5	1.1	300	8.5	6.0	0.71	1.17	12.5	7.3						
	1.5	0.5	1.1	400	8.9	6.8	0.77	1.22	13.1	7.3						
	2.3	1.6	3.6	300	9.1	6.2	0.68	1.12	12.9	8.1						
	2.3	1.6	3.6	400	9.4	7.0	0.74	1.16	13.4	8.1						
	3.0	3.2	7.3	300	9.4	6.3	0.67	1.09	13.1	8.6						
	3.0	3.2	7.3	400	9.8	7.1	0.73	1.14	13.7	8.6						
120	1.5	0.4	1.0	300	7.5	5.7	0.76	1.27	11.8	5.9						
	1.5	0.4	1.0	400	7.8	6.4	0.82	1.32	12.3	5.9						
	2.3	1.5	3.4	300	8.0	5.8	0.73	1.22	12.2	6.6						
	2.3	1.5	3.4	400	8.3	6.6	0.79	1.27	12.7	6.6						
	3.0	3.0	7.0	300	8.3	5.9	0.71	1.19	12.4	7.0						
	3.0	3.0	7.0	400	8.7	6.7	0.77	1.24	12.9	7.0						

LEGEND

- AHRI — Air Conditioning, Heating, and Refrigeration Institute
- COP — Coefficient of Performance
- db — Dry Bulb
- EAT — Entering Air Temperature
- EER — Energy Efficiency Ratio
- EWT — Entering Water Temperature
- GPM — Gallons Per Minute
- HE — Heat of Extraction (MBtuh)
- ISO — International Organization for Standardization
- LAT — Leaving Air Temperature (F)
- MBtuh — Btuh in Thousands
- TC — Total Capacity (MBtuh)
- THC — Total Heating Capacity (MBtuh)
- THR — Total Heat Rejection (MBtuh)
- TSC — Total Sensible Capacity (MBtuh)
- wb — Wet Bulb

*Performance capacities shown in thousands of Btuh.

NOTES:

1. Interpolation is permissible; extrapolation is not.
2. All entering air conditions are 80 F db and 67 F wb in cooling, and 70 F db in heating. AHRI/ISO certified conditions are 80.6 F db and 66.2 F wb in cooling and 68 F db in heating.
3. Table does not reflect fan or pump power corrections for AHRI/ISO conditions.
4. All performance is based upon the lower voltage of dual voltage rated units.
5. Operation below 40 F EWT is based upon a 15% methanol antifreeze solution.
6. Operation below 60 F EWT requires optional insulated water/refrigerant circuit.
7. See performance correction tables for operating conditions other than those listed above.



50P1H,P1V015
525 CFM NOMINAL AIRFLOW COOLING/525 CFM NOMINAL AIRFLOW HEATING*

EWT (F)	GPM	PRESSURE DROP		COOLING — EAT 80/67 F							HEATING — EAT 70 F					
		PSI	ft wg	Airflow CFM	TC	TSC	Sens/Tot Ratio	kW	THR	EER	Airflow CFM	THC	kW	HE	LAT	COP
20	3.8	4.1	9.5	Operation Not Recommended							395	9.5	1.07	6.1	92	2.62
	3.8	4.1	9.5	Operation Not Recommended							525	9.8	0.96	6.5	87	2.98
30	1.9	1.0	2.3	395	17.3	10.8	0.62	0.61	19.4	28.4	395	10.6	1.09	7.1	95	2.84
	1.9	1.0	2.3	525	18.1	12.2	0.67	0.64	20.2	28.4	525	10.9	0.98	7.5	89	3.24
	2.8	1.8	4.3	395	17.5	10.8	0.62	0.56	19.4	31.1	395	11.1	1.11	7.5	96	2.94
	2.8	1.8	4.3	525	18.2	12.2	0.67	0.59	20.2	31.1	525	11.4	0.99	8.0	90	3.35
	3.8	3.3	7.7	395	17.5	10.8	0.62	0.54	19.4	32.2	395	11.3	1.11	7.7	97	2.99
	3.8	3.3	7.7	525	18.3	12.2	0.67	0.57	20.2	32.2	525	11.6	1.00	8.2	90	3.41
40	1.9	0.8	1.8	395	17.0	10.6	0.63	0.68	19.3	24.8	395	12.3	1.13	8.5	99	3.18
	1.9	0.8	1.8	525	17.7	12.0	0.68	0.71	20.1	24.8	525	12.6	1.02	9.1	92	3.62
	2.8	1.6	3.6	395	17.2	10.7	0.62	0.63	19.4	27.3	395	12.8	1.14	9.0	100	3.29
	2.8	1.6	3.6	525	18.0	12.1	0.68	0.66	20.2	27.3	525	13.1	1.03	9.7	93	3.75
	3.8	2.9	6.6	395	17.4	10.8	0.62	0.60	19.4	28.8	395	13.1	1.15	9.3	101	3.35
	3.8	2.9	6.6	525	18.1	12.2	0.67	0.63	20.2	28.8	525	13.5	1.03	10.0	94	3.82
50	1.9	0.6	1.5	395	16.4	10.4	0.63	0.76	19.0	21.6	395	13.9	1.16	10.0	103	3.50
	1.9	0.6	1.5	525	17.1	11.8	0.69	0.79	19.8	21.6	525	14.2	1.05	10.7	95	3.99
	2.8	1.4	3.1	395	16.8	10.6	0.63	0.71	19.2	23.8	395	14.6	1.18	10.6	104	3.63
	2.8	1.4	3.1	525	17.5	12.0	0.68	0.74	20.0	23.8	525	14.9	1.06	11.3	96	4.13
	3.8	2.5	5.8	395	17.0	10.6	0.63	0.68	19.3	25.0	395	14.9	1.18	10.9	105	3.69
	3.8	2.5	5.8	525	17.7	12.0	0.68	0.71	20.1	25.0	525	15.3	1.06	11.7	97	4.21
60	1.9	0.6	1.3	395	15.7	10.2	0.65	0.84	18.6	18.7	395	15.5	1.20	11.5	106	3.81
	1.9	0.6	1.3	525	16.4	11.5	0.70	0.88	19.4	18.7	525	15.9	1.07	12.2	98	4.34
	2.8	1.2	2.8	395	16.2	10.4	0.64	0.79	18.9	20.5	395	16.3	1.21	12.1	108	3.94
	2.8	1.2	2.8	525	16.9	11.7	0.69	0.82	19.7	20.5	525	16.7	1.09	13.0	99	4.50
	3.8	2.3	5.3	395	16.4	10.4	0.63	0.76	19.0	21.6	395	16.7	1.22	12.5	109	4.02
	3.8	2.3	5.3	525	17.1	11.8	0.69	0.79	19.8	21.6	525	17.1	1.09	13.3	100	4.58
70	1.9	0.5	1.1	395	15.2	10.1	0.66	0.93	18.3	16.2	395	17.1	1.22	12.9	110	4.10
	1.9	0.5	1.1	525	15.8	11.4	0.72	0.97	19.1	16.3	525	17.5	1.10	13.8	101	4.68
	2.8	1.1	2.5	395	15.5	10.1	0.65	0.88	18.5	17.6	395	18.0	1.24	13.7	112	4.25
	2.8	1.1	2.5	525	16.1	11.4	0.71	0.91	19.2	17.6	525	18.4	1.11	14.6	102	4.85
	3.8	2.1	4.9	395	15.8	10.2	0.65	0.85	18.6	18.6	395	18.4	1.25	14.1	113	4.33
	3.8	2.1	4.9	525	16.4	11.5	0.70	0.88	19.4	18.6	525	18.8	1.12	15.0	103	4.94
80	1.9	0.4	1.0	395	14.3	9.8	0.68	1.03	17.8	13.9	395	18.7	1.25	14.3	114	4.38
	1.9	0.4	1.0	525	14.9	11.1	0.74	1.07	18.5	13.9	525	19.2	1.12	15.3	104	5.00
	2.8	1.0	2.4	395	14.7	9.8	0.67	0.97	18.0	15.1	395	19.6	1.27	15.1	116	4.54
	2.8	1.0	2.4	525	15.3	11.1	0.73	1.01	18.7	15.1	525	20.1	1.14	16.2	105	5.18
	3.8	2.0	4.6	395	14.9	9.9	0.66	0.94	18.2	15.9	395	20.1	1.27	15.6	117	4.62
	3.8	2.0	4.6	525	15.6	11.2	0.72	0.98	18.9	15.9	525	20.6	1.14	16.6	106	5.27
85	1.9	0.4	0.9	395	13.8	9.6	0.70	1.10	17.5	12.8	395	19.5	1.26	15.0	116	4.52
	1.9	0.4	0.9	525	14.4	10.9	0.76	1.13	18.2	12.8	525	19.9	1.13	16.0	105	5.15
	2.8	1.0	2.3	395	14.2	9.7	0.68	1.02	17.7	13.9	395	20.4	1.28	15.9	118	4.68
	2.8	1.0	2.3	525	14.8	11.0	0.74	1.07	18.4	13.9	525	20.9	1.15	16.9	107	5.34
	3.8	1.9	4.4	395	14.5	9.8	0.67	0.99	17.9	14.7	395	20.9	1.29	16.3	119	4.77
	3.8	1.9	4.4	525	15.1	11.1	0.73	1.03	18.6	14.7	525	21.4	1.15	17.4	108	5.43
90	1.9	0.4	0.9	395	13.3	9.5	0.71	1.14	17.2	11.7	395	20.2	1.28	15.7	117	4.65
	1.9	0.4	0.9	525	13.9	10.7	0.77	1.19	18.0	11.7	525	20.7	1.15	16.8	107	5.30
	2.8	1.0	2.2	395	13.7	9.5	0.69	1.08	17.4	12.8	395	21.2	1.29	16.6	120	4.82
	2.8	1.0	2.2	525	14.3	10.8	0.75	1.12	18.1	12.8	525	21.7	1.16	17.7	108	5.49
	3.8	1.9	4.3	395	14.1	9.6	0.69	1.04	17.6	13.5	395	21.7	1.30	17.1	121	4.90
	3.8	1.9	4.3	525	14.6	10.9	0.74	1.08	18.3	13.5	525	22.2	1.17	18.2	109	5.59
100	1.9	0.4	0.8	395	12.4	9.2	0.74	1.25	16.6	9.9	Operation Not Recommended					
	1.9	0.4	0.8	525	12.9	10.4	0.80	1.31	17.3	9.9						
	2.8	0.9	2.1	395	12.8	9.2	0.72	1.19	16.8	10.8						
	2.8	0.9	2.1	525	13.3	10.4	0.78	1.23	17.5	10.8						
	3.8	1.8	4.1	395	13.1	9.3	0.71	1.15	17.0	11.4						
	3.8	1.8	4.1	525	13.6	10.5	0.77	1.20	17.7	11.4						
110	1.9	0.3	0.7	395	11.3	8.8	0.78	1.37	16.0	8.3						
	1.9	0.3	0.7	525	11.8	10.0	0.84	1.43	16.7	8.3						
	2.8	0.8	1.9	395	11.8	8.9	0.75	1.30	16.2	9.0						
	2.8	0.8	1.9	525	12.2	10.0	0.82	1.36	16.9	9.0						
	3.8	1.7	3.9	395	12.1	9.0	0.74	1.27	16.4	9.5						
	3.8	1.7	3.9	525	12.6	10.2	0.81	1.32	17.1	9.5						
120	1.9	0.3	0.7	395	10.3	8.5	0.82	1.50	15.5	6.9						
	1.9	0.3	0.7	525	10.8	9.6	0.89	1.56	16.1	6.9						
	2.8	0.8	1.8	395	10.7	8.5	0.79	1.43	15.6	7.5						
	2.8	0.8	1.8	525	11.2	9.6	0.86	1.48	16.2	7.5						
	3.8	1.6	3.7	395	11.0	8.6	0.78	1.39	15.8	7.9						
	3.8	1.6	3.7	525	11.5	9.8	0.85	1.45	16.4	7.9						

LEGEND

- AHRI — Air Conditioning, Heating, and Refrigeration Institute
- COP — Coefficient of Performance
- db — Dry Bulb
- EAT — Entering Air Temperature
- EER — Energy Efficiency Ratio
- EWT — Entering Water Temperature
- GPM — Gallons Per Minute
- HE — Heat of Extraction (MBtuh)
- ISO — International Organization for Standardization
- LAT — Leaving Air Temperature (F)
- MBtuh — Btuh in Thousands
- TC — Total Capacity (MBtuh)
- THC — Total Heating Capacity (MBtuh)
- THR — Total Heat Rejection (MBtuh)
- TSC — Total Sensible Capacity (MBtuh)
- wb — Wet Bulb

*Performance capacities shown in thousands of Btuh.

NOTES:

1. Interpolation is permissible; extrapolation is not.
2. All entering air conditions are 80 F db and 67 F wb in cooling, and 70 F db in heating. AHRI/ISO certified conditions are 80.6 F db and 66.2 F wb in cooling and 68 F db in heating.
3. Table does not reflect fan or pump power corrections for AHRI/ISO conditions.
4. All performance is based upon the lower voltage of dual voltage rated units.
5. Operation below 40 F EWT is based upon a 15% methanol antifreeze solution.
6. Operation below 60 F EWT requires optional insulated water/refrigerant circuit.
7. See performance correction tables for operating conditions other than those listed above.

Performance data (cont)



50P1H,P1V018

600 CFM NOMINAL AIRFLOW COOLING/600 CFM NOMINAL AIRFLOW HEATING*

EWT (F)	GPM	PRESSURE DROP		COOLING — EAT 80/67 F							HEATING — EAT 70 F					
		PSI	ft wg	Airflow CFM	TC	TSC	Sens/Tot Ratio	kW	THR	EER	Airflow CFM	THC	kW	HE	LAT	COP
20	4.5	7.2	16.7	Operation Not Recommended							450	11.2	1.25	7.2	93.	2.61
	4.5	7.2	16.7	Operation Not Recommended							600	11.4	1.13	7.6	88.	2.98
30	2.3	2.1	4.9	450	22.1	14.2	0.64	0.72	24.5	30.7	450	12.4	1.29	8.2	96	2.83
	2.3	2.1	4.9	600	23.0	16.1	0.70	0.75	25.5	30.8	600	12.7	1.16	8.8	90	3.22
	3.4	3.4	7.9	450	22.9	14.4	0.63	0.64	25.1	35.8	450	12.9	1.30	8.7	97	2.92
	3.4	3.4	7.9	600	23.9	16.3	0.68	0.67	26.1	35.8	600	13.3	1.17	9.3	90	3.33
	4.5	5.9	13.7	450	23.3	14.4	0.62	0.60	25.3	39.0	450	13.2	1.31	9.0	97	2.97
	4.5	5.9	13.7	600	24.3	16.3	0.67	0.62	26.4	39.0	600	13.5	1.17	9.6	91	3.38
40	2.3	1.7	3.9	450	21.1	13.9	0.66	0.82	23.9	25.6	450	14.3	1.33	9.9	99	3.15
	2.3	1.7	3.9	600	22.0	15.7	0.72	0.86	24.9	25.6	600	14.7	1.20	10.6	93	3.59
	3.4	2.9	6.7	450	21.9	14.2	0.65	0.75	24.4	29.3	450	15.0	1.35	10.5	101	3.26
	3.4	2.9	6.7	600	22.8	16.0	0.70	0.78	25.4	29.3	600	15.3	1.21	11.2	94	3.72
	4.5	5.1	11.8	450	22.5	14.5	0.64	0.71	24.9	31.9	450	15.3	1.35	10.8	102	3.32
	4.5	5.1	11.8	600	23.5	16.4	0.70	0.74	25.9	31.9	600	15.7	1.22	11.6	94	3.78
50	2.3	1.4	3.3	450	20.4	13.7	0.67	0.93	23.5	21.9	450	16.3	1.37	11.7	103	3.47
	2.3	1.4	3.3	600	21.2	15.5	0.73	0.97	24.5	22.0	600	16.6	1.23	12.5	96	3.96
	3.4	2.6	5.9	450	20.8	13.8	0.66	0.85	23.7	24.4	450	17.0	1.39	12.4	105	3.60
	3.4	2.6	5.9	600	21.7	15.6	0.72	0.89	24.7	24.4	600	17.4	1.25	13.2	97	4.10
	4.5	4.6	10.6	450	21.2	13.9	0.66	0.81	23.9	26.1	450	17.4	1.39	12.7	106	3.67
	4.5	4.6	10.6	600	22.1	15.8	0.72	0.85	24.9	26.1	600	17.9	1.25	13.6	98	4.18
60	2.3	1.3	2.9	450	19.3	13.2	0.68	1.04	22.8	18.6	450	18.2	1.41	13.4	107	3.79
	2.3	1.3	2.9	600	20.1	14.9	0.74	1.08	23.8	18.6	600	18.6	1.26	14.3	99	4.32
	3.4	2.3	5.3	450	19.8	13.4	0.68	0.96	23.0	20.6	450	19.1	1.42	14.2	109	3.93
	3.4	2.3	5.3	600	20.6	15.1	0.73	1.00	24.0	20.6	600	19.6	1.28	15.2	100	4.49
	4.5	4.2	9.6	450	20.1	13.5	0.67	0.92	23.3	21.9	450	19.6	1.43	14.7	110	4.01
	4.5	4.2	9.6	600	21.0	15.3	0.73	0.96	24.2	21.9	600	20.1	1.29	15.7	101	4.58
70	2.3	1.1	2.6	450	18.2	12.7	0.69	1.15	22.1	15.8	450	20.2	1.44	15.2	112	4.11
	2.3	1.1	2.6	600	19.0	14.3	0.76	1.20	23.1	15.8	600	20.7	1.29	16.2	102	4.68
	3.4	2.1	4.9	450	18.7	12.8	0.69	1.07	22.3	17.4	450	21.2	1.46	16.1	114	4.27
	3.4	2.1	4.9	600	19.4	14.5	0.75	1.12	23.2	17.4	600	21.7	1.31	17.2	103	4.86
	4.5	3.9	8.9	450	19.1	13.0	0.68	1.03	22.6	18.4	450	21.7	1.46	16.6	115	4.35
	4.5	3.9	8.9	600	19.8	14.7	0.74	1.08	23.5	18.4	600	22.3	1.32	17.8	104	4.96
80	2.3	1.0	2.3	450	17.0	12.1	0.71	1.28	21.4	13.3	450	22.1	1.47	17.0	116	4.41
	2.3	1.0	2.3	600	17.7	13.7	0.77	1.33	22.3	13.3	600	22.7	1.32	18.2	105	5.03
	3.4	2.0	4.5	450	17.5	12.3	0.70	1.20	21.6	14.7	450	23.3	1.49	18.0	118	4.59
	3.4	2.0	4.5	600	18.3	13.9	0.76	1.25	22.5	14.7	600	23.9	1.34	19.3	107	5.23
	4.5	3.6	8.3	450	17.9	12.5	0.69	1.15	21.9	15.5	450	23.9	1.50	18.6	119	4.68
	4.5	3.6	8.3	600	18.7	14.1	0.76	1.20	22.8	15.5	600	24.5	1.35	19.9	108	5.34
85	2.3	1.0	2.2	450	16.4	11.8	0.72	1.35	21.0	12.2	450	23.1	1.49	17.9	118	4.56
	2.3	1.0	2.2	600	17.1	13.3	0.78	1.40	21.9	12.2	600	23.7	1.33	19.1	107	5.20
	3.4	1.9	4.4	450	16.9	12.0	0.71	1.26	21.2	13.5	450	24.3	1.50	19.0	120	4.74
	3.4	1.9	4.4	600	17.6	13.5	0.77	1.31	22.1	13.5	600	24.9	1.35	20.3	108	5.41
	4.5	3.5	8.1	450	17.3	12.2	0.70	1.22	21.5	14.3	450	25.0	1.51	19.6	121	4.84
	4.5	3.5	8.1	600	18.0	13.8	0.76	1.27	22.4	14.3	600	25.6	1.36	20.9	110	5.51
90	2.3	0.9	2.1	450	15.8	11.5	0.73	1.42	20.6	11.1	450	24.1	1.50	18.8	120	4.71
	2.3	0.9	2.1	600	16.4	13.0	0.79	1.48	21.5	11.1	600	24.7	1.35	20.1	108	5.37
	3.4	1.8	4.2	450	16.3	11.7	0.71	1.33	20.8	12.3	450	25.4	1.52	20.0	122	4.89
	3.4	1.8	4.2	600	17.0	13.2	0.78	1.38	21.7	12.3	600	26.0	1.37	21.3	110	5.58
	4.5	3.4	7.9	450	16.7	11.9	0.71	1.28	21.1	13.0	450	26.1	1.53	20.6	124	4.99
	4.5	3.4	7.9	600	17.4	13.4	0.77	1.34	22.0	13.0	600	26.7	1.38	22.0	111	5.69
100	2.3	0.9	2.0	450	14.4	10.8	0.75	1.57	19.8	9.2	Operation Not Recommended					
	2.3	0.9	2.0	600	15.0	12.2	0.82	1.63	20.6	9.2						
	3.4	1.7	4.0	450	15.0	11.0	0.74	1.48	20.0	10.1						
	3.4	1.7	4.0	600	15.6	12.5	0.80	1.54	20.8	10.1						
	4.5	3.2	7.4	450	15.4	11.2	0.73	1.43	20.3	10.8						
	4.5	3.2	7.4	600	16.0	12.7	0.79	1.49	21.1	10.8						
110	2.3	0.8	1.8	450	12.9	10.1	0.78	1.74	18.8	7.4						
	2.3	0.8	1.8	600	13.4	11.4	0.85	1.81	19.6	7.4						
	3.4	1.6	3.8	450	13.5	10.3	0.76	1.64	19.1	8.2						
	3.4	1.6	3.8	600	14.0	11.6	0.83	1.71	19.9	8.2						
	4.5	3.1	7.1	450	13.9	10.5	0.75	1.59	19.4	8.8						
	4.5	3.1	7.1	600	14.5	11.9	0.82	1.65	20.2	8.8						
120	2.3	0.7	1.7	450	11.2	9.2	0.82	1.92	17.8	5.8						
	2.3	0.7	1.7	600	11.6	10.4	0.89	2.00	18.5	5.8						
	3.4	1.6	3.6	450	11.8	9.5	0.80	1.82	18.1	6.5						
	3.4	1.6	3.6	600	12.3	10.7	0.87	1.89	18.8	6.5						
	4.5	2.9	6.8	450	12.3	9.7	0.79	1.77	18.4	7.0						
	4.5	2.9	6.8	600	12.8	11.0	0.86	1.84	19.1	7.0						

LEGEND

- AHRI — Air Conditioning, Heating, and Refrigeration Institute
- COP — Coefficient of Performance
- db — Dry Bulb
- EAT — Entering Air Temperature
- EER — Energy Efficiency Ratio
- EWT — Entering Water Temperature
- GPM — Gallons Per Minute
- HE — Heat of Extraction (MBtuh)
- ISO — International Organization for Standardization
- LAT — Leaving Air Temperature (F)
- MBtuh — Btuh in Thousands
- TC — Total Capacity (MBtuh)
- THC — Total Heating Capacity (MBtuh)
- THR — Total Heat Rejection (MBtuh)
- TSC — Total Sensible Capacity (MBtuh)
- wb — Wet Bulb

*Performance capacities shown in thousands of Btuh.

NOTES:

1. Interpolation is permissible; extrapolation is not.
2. All entering air conditions are 80 F db and 67 F wb in cooling, and 70 F db in heating. AHRI/ISO certified conditions are 80.6 F db and 66.2 F wb in cooling and 68 F db in heating.
3. Table does not reflect fan or pump power corrections for AHRI/ISO conditions.
4. All performance is based upon the lower voltage of dual voltage rated units.
5. Operation below 40 F EWT is based upon a 15% methanol antifreeze solution.
6. Operation below 60 F EWT requires optional insulated water/refrigerant circuit.
7. See performance correction tables for operating conditions other than those listed above.



50P1H,P1V024
800 CFM NOMINAL AIRFLOW COOLING/800 CFM NOMINAL AIRFLOW HEATING*

EWT (F)	GPM	PRESSURE DROP		COOLING — EAT 80/67 F							HEATING — EAT 70 F					
		PSI	ft wg	Airflow CFM	TC	TSC	Sens/Tot Ratio	kW	THR	EER	Airflow CFM	THC	kW	HE	LAT	COP
20	6.0	8.5	19.6	Operation Not Recommended							640	15.5	1.91	9.5	92	2.39
	6.0	8.5	19.6	850							850	15.9	1.71	10.1	87	2.72
30	3.0	2.2	5.2	640	27.7	17.4	0.63	1.12	31.5	24.8	640	17.2	1.93	11.0	95	2.61
	3.0	2.2	5.2	850	28.9	19.7	0.68	1.16	32.8	24.8	850	17.6	1.74	11.8	89	2.98
	4.5	4.0	9.3	640	28.2	17.5	0.62	1.05	31.8	26.9	640	18.0	1.95	11.7	96	2.70
	4.5	4.0	9.3	850	29.4	19.8	0.67	1.09	33.1	26.9	850	18.4	1.75	12.5	90	3.08
	6.0	7.2	16.7	640	28.5	17.5	0.62	1.02	31.9	28.0	640	18.4	1.95	12.1	97	2.76
	6.0	7.2	16.7	850	29.6	19.8	0.67	1.06	33.2	28.0	850	18.8	1.76	12.9	91	3.14
40	3.0	1.9	4.4	640	26.9	17.1	0.64	1.23	31.1	21.9	640	19.9	1.98	13.4	99	2.94
	3.0	1.9	4.4	850	28.0	19.4	0.69	1.28	32.4	21.9	850	20.4	1.78	14.4	92	3.36
	4.5	3.6	8.2	640	27.5	17.3	0.63	1.15	31.4	24.0	640	20.8	2.00	14.3	100	3.06
	4.5	3.6	8.2	850	28.7	19.6	0.68	1.19	32.7	24.0	850	21.3	1.79	15.3	93	3.49
	6.0	6.4	14.9	640	27.8	17.4	0.63	1.11	31.5	25.1	640	21.3	2.01	14.7	101	3.12
	6.0	6.4	14.9	850	28.9	19.7	0.68	1.16	32.8	25.1	850	21.9	1.80	15.7	94	3.55
50	3.0	1.7	3.9	640	26.2	16.9	0.65	1.36	30.8	19.3	640	22.6	2.03	15.9	103	3.27
	3.0	1.7	3.9	850	27.3	19.1	0.70	1.42	32.1	19.3	850	23.2	1.82	17.0	95	3.72
	4.5	3.2	7.4	640	26.7	17.0	0.64	1.26	31.0	21.1	640	23.7	2.05	16.9	104	3.39
	4.5	3.2	7.4	850	27.8	19.3	0.69	1.32	32.2	21.1	850	24.3	1.84	18.0	96	3.87
	6.0	5.9	13.6	640	27.0	17.1	0.64	1.22	31.1	22.1	640	24.3	2.06	17.4	105	3.46
	6.0	5.9	13.6	850	28.1	19.4	0.69	1.27	32.4	22.1	850	24.9	1.85	18.6	97	3.94
60	3.0	1.5	3.5	640	25.3	16.6	0.66	1.52	30.4	16.7	640	25.3	2.08	18.3	107	3.57
	3.0	1.5	3.5	850	26.3	18.8	0.71	1.58	31.7	16.7	850	25.9	1.87	19.6	98	4.07
	4.5	3.0	6.9	640	25.7	16.7	0.65	1.40	30.5	18.3	640	26.6	2.10	19.4	108	3.70
	4.5	3.0	6.9	850	26.8	18.9	0.70	1.46	31.7	18.3	850	27.2	1.89	20.7	100	4.22
	6.0	5.5	12.6	640	26.1	16.8	0.64	1.35	30.6	19.3	640	27.2	2.12	20.0	109	3.77
	6.0	5.5	12.6	850	27.1	19.0	0.70	1.41	31.9	19.3	850	27.9	1.90	21.4	100	4.30
70	3.0	1.3	3.0	640	22.9	15.7	0.69	1.91	29.4	12.0	640	30.4	2.18	22.9	114	4.08
	3.0	1.3	3.0	850	23.8	17.8	0.75	1.99	30.6	12.0	850	31.1	1.96	24.4	104	4.65
	4.5	2.6	6.1	640	23.4	15.8	0.67	1.76	29.4	13.3	640	31.7	2.21	24.0	116	4.20
	4.5	2.6	6.1	850	24.4	17.9	0.73	1.84	30.7	13.3	850	32.5	1.99	25.7	105	4.79
	6.0	4.9	11.3	640	23.8	16.0	0.67	1.70	29.6	14.1	640	32.4	2.23	24.6	117	4.26
	6.0	4.9	11.3	850	24.8	18.1	0.73	1.77	30.8	14.1	850	33.1	2.00	26.3	106	4.85
80	3.0	1.3	2.9	640	22.2	15.5	0.70	2.03	29.2	11.0	640	31.5	2.21	23.8	116	4.18
	3.0	1.3	2.9	850	23.1	17.5	0.76	2.12	30.4	11.0	850	32.3	1.98	25.5	105	4.77
	4.5	2.6	5.9	640	22.8	15.6	0.68	1.88	29.2	12.2	640	32.7	2.24	25.0	117	4.29
	4.5	2.6	5.9	850	23.7	17.6	0.74	1.95	30.4	12.2	850	33.5	2.01	26.7	107	4.89
	6.0	4.8	11.0	640	23.2	15.7	0.68	1.80	29.3	12.9	640	33.4	2.25	25.5	118	4.34
	6.0	4.8	11.0	850	24.1	17.8	0.74	1.88	30.5	12.9	850	34.2	2.02	27.2	107	4.95
85	3.0	1.2	2.8	640	21.6	15.3	0.71	2.16	28.9	10.0	640	32.6	2.23	24.8	117	4.28
	3.0	1.2	2.8	850	22.4	17.3	0.77	2.25	30.1	10.0	850	33.4	2.01	26.5	106	4.88
	4.5	2.5	5.8	640	22.2	15.4	0.69	1.99	29.0	11.1	640	33.8	2.26	25.9	119	4.38
	4.5	2.5	5.8	850	23.1	17.4	0.75	2.07	30.1	11.1	850	34.6	2.03	27.6	108	4.99
	6.0	4.7	10.7	640	22.5	15.4	0.69	1.91	29.0	11.8	640	34.4	2.28	26.4	120	4.42
	6.0	4.7	10.7	850	23.4	17.5	0.75	1.99	30.2	11.8	850	35.2	2.05	28.2	108	5.04
90	3.0	1.2	2.8	640	21.6	15.3	0.71	2.16	28.9	10.0	640	32.6	2.23	24.8	117	4.28
	3.0	1.2	2.8	850	22.4	17.3	0.77	2.25	30.1	10.0	850	33.4	2.01	26.5	106	4.88
	4.5	2.5	5.8	640	22.2	15.4	0.69	1.99	29.0	11.1	640	33.8	2.26	25.9	119	4.38
	4.5	2.5	5.8	850	23.1	17.4	0.75	2.07	30.1	11.1	850	34.6	2.03	27.6	108	4.99
	6.0	4.7	10.7	640	22.5	15.4	0.69	1.91	29.0	11.8	640	34.4	2.28	26.4	120	4.42
	6.0	4.7	10.7	850	23.4	17.5	0.75	1.99	30.2	11.8	850	35.2	2.05	28.2	108	5.04
100	3.0	1.2	2.7	640	20.2	14.8	0.74	2.44	28.5	8.3	Operation Not Recommended					
	3.0	1.2	2.7	850	21.0	16.8	0.80	2.54	29.7	8.3						
	4.5	2.4	5.5	640	20.8	14.9	0.72	2.25	28.5	9.2						
	4.5	2.4	5.5	850	21.6	16.9	0.78	2.34	29.7	9.2						
	6.0	4.5	10.3	640	21.1	15.0	0.71	2.16	28.5	9.8						
	6.0	4.5	10.3	850	22.0	17.0	0.77	2.25	29.7	9.8						
110	3.0	1.1	2.5	640	18.8	14.4	0.77	2.77	28.3	6.8						
	3.0	1.1	2.5	850	19.5	16.3	0.84	2.88	29.4	6.8						
	4.5	2.3	5.3	640	19.3	14.4	0.75	2.55	28.1	7.6						
	4.5	2.3	5.3	850	20.1	16.3	0.81	2.66	29.2	7.6						
	6.0	4.3	9.9	640	19.7	14.5	0.74	2.45	28.1	8.0						
	6.0	4.3	9.9	850	20.5	16.4	0.80	2.55	29.3	8.0						
120	3.0	1.0	2.4	640	17.1	13.9	0.81	3.13	27.9	5.5						
	3.0	1.0	2.4	850	17.8	15.7	0.88	3.26	29.0	5.5						
	4.5	2.2	5.1	640	17.8	14.0	0.78	2.89	27.8	6.2						
	4.5	2.2	5.1	850	18.6	15.8	0.85	3.01	28.9	6.2						
	6.0	4.2	9.6	640	18.3	14.1	0.77	2.78	27.9	6.6						
	6.0	4.2	9.6	850	19.1	16.0	0.84	2.89	29.0	6.6						

LEGEND

- AHRI — Air Conditioning, Heating, and Refrigeration Institute
- COP — Coefficient of Performance
- db — Dry Bulb
- EAT — Entering Air Temperature
- EER — Energy Efficiency Ratio
- EWT — Entering Water Temperature
- GPM — Gallons Per Minute
- HE — Heat of Extraction (MBtuh)
- ISO — International Organization for Standardization
- LAT — Leaving Air Temperature (F)
- MBtuh — Btuh in Thousands
- TC — Total Capacity (MBtuh)
- THC — Total Heating Capacity (MBtuh)
- THR — Total Heat Rejection (MBtuh)
- TSC — Total Sensible Capacity (MBtuh)
- wb — Wet Bulb

*Performance capacities shown in thousands of Btuh.

NOTES:

1. Interpolation is permissible; extrapolation is not.
2. All entering air conditions are 80 F db and 67 F wb in cooling, and 70 F db in heating. AHRI/ISO certified conditions are 80.6 F db and 66.2 F wb in cooling and 68 F db in heating.
3. Table does not reflect fan or pump power corrections for AHRI/ISO conditions.
4. All performance is based upon the lower voltage of dual voltage rated units.
5. Operation below 40 F EWT is based upon a 15% methanol antifreeze solution.
6. Operation below 60 F EWT requires optional insulated water/refrigerant circuit.
7. See performance correction tables for operating conditions other than those listed above.

Performance data (cont)



50P1H,P1V030

1000 CFM NOMINAL AIRFLOW COOLING/1000 CFM NOMINAL AIRFLOW HEATING*

EWT (F)	GPM	PRESSURE DROP		COOLING — EAT 80/67 F							HEATING — EAT 70 F					
		PSI	ft wg	Airflow CFM	TC	TSC	Sens/Tot Ratio	kW	THR	EER	Airflow CFM	THC	kW	HE	LAT	COP
20	7.5	5.0	11.6	Operation Not Recommended							750	20.0	2.31	12.6	95	2.53
	7.5	5.0	11.6	Operation Not Recommended							1000	20.4	2.08	13.4	89	2.89
30	3.8	1.3	2.9	750	33.3	20.3	0.61	1.38	38.0	24.0	750	21.6	2.37	14.0	97	2.67
	3.8	1.3	2.9	1000	34.7	22.9	0.66	1.44	39.5	24.0	1000	22.1	2.13	14.9	90	3.04
	5.6	2.3	5.4	750	33.5	20.2	0.60	1.31	37.9	25.7	750	22.5	2.40	14.7	98	2.75
	5.6	2.3	5.4	1000	34.9	22.8	0.65	1.36	39.5	25.7	1000	23.0	2.15	15.7	91	3.13
	7.5	4.2	9.7	750	33.6	20.0	0.60	1.27	37.9	26.5	750	22.9	2.41	15.1	98	2.79
	7.5	4.2	9.7	1000	35.0	22.7	0.65	1.32	39.4	26.5	1000	23.5	2.16	16.2	92	3.18
40	3.8	1.0	2.4	750	32.6	20.2	0.62	1.51	37.7	21.6	750	24.7	2.45	16.7	100	2.95
	3.8	1.0	2.4	1000	34.0	22.8	0.67	1.57	39.3	21.6	1000	25.3	2.20	17.8	93	3.36
	5.6	2.0	4.7	750	33.1	20.3	0.61	1.42	37.9	23.3	750	25.7	2.48	17.6	102	3.04
	5.6	2.0	4.7	1000	34.5	22.9	0.67	1.48	39.5	23.3	1000	26.4	2.23	18.8	94	3.47
	7.5	3.7	8.6	750	33.7	20.5	0.61	1.38	38.3	24.4	750	26.3	2.49	18.1	102	3.10
	7.5	3.7	8.6	1000	35.1	23.2	0.66	1.44	39.9	24.4	1000	26.9	2.24	19.4	95	3.53
50	3.8	0.9	2.1	750	31.6	19.9	0.63	1.65	37.2	19.2	750	27.8	2.52	19.5	104	3.24
	3.8	0.9	2.1	1000	32.9	22.5	0.68	1.72	38.8	19.2	1000	28.5	2.26	20.8	96	3.69
	5.6	1.8	4.2	750	32.3	20.1	0.62	1.55	37.6	20.9	750	29.1	2.55	20.6	106	3.35
	5.6	1.8	4.2	1000	33.7	22.8	0.68	1.61	39.1	20.9	1000	29.8	2.29	22.0	98	3.82
	7.5	3.4	7.8	750	32.6	20.2	0.62	1.50	37.7	21.7	750	29.8	2.56	21.3	107	3.41
	7.5	3.4	7.8	1000	34.0	22.9	0.67	1.57	39.3	21.7	1000	30.5	2.30	22.7	98	3.89
60	3.8	0.8	1.8	750	30.4	19.4	0.64	1.81	36.6	16.8	750	31.0	2.58	22.4	108	3.52
	3.8	0.8	1.8	1000	31.7	21.9	0.69	1.89	38.1	16.8	1000	31.8	2.32	23.9	99	4.02
	5.6	1.7	3.8	750	31.1	19.6	0.63	1.70	36.9	18.3	750	32.5	2.61	23.7	110	3.65
	5.6	1.7	3.8	1000	32.4	22.2	0.69	1.77	38.4	18.3	1000	33.3	2.34	25.3	101	4.16
	7.5	3.1	7.2	750	31.4	19.7	0.63	1.65	37.0	19.0	750	33.3	2.63	24.4	111	3.71
	7.5	3.1	7.2	1000	32.7	22.3	0.68	1.71	38.5	19.1	1000	34.1	2.36	26.0	102	4.24
70	3.8	0.7	1.6	750	29.0	18.8	0.65	2.00	35.8	14.5	750	34.2	2.64	25.2	112	3.79
	3.8	0.7	1.6	1000	30.2	21.2	0.70	2.08	37.3	14.5	1000	35.1	2.37	26.9	102	4.33
	5.6	1.5	3.6	750	30.0	19.2	0.64	1.87	36.3	16.0	750	35.8	2.68	26.7	114	3.92
	5.6	1.5	3.6	1000	31.2	21.7	0.70	1.95	37.8	16.0	1000	36.7	2.40	28.5	104	4.47
	7.5	2.9	6.7	750	30.4	19.4	0.64	1.81	36.6	16.8	750	36.7	2.70	27.4	115	3.99
	7.5	2.9	6.7	1000	31.7	21.9	0.69	1.89	38.1	16.8	1000	37.6	2.42	29.3	105	4.55
80	3.8	0.7	1.5	750	27.7	18.3	0.66	2.21	35.3	12.5	750	37.3	2.71	28.0	116	4.04
	3.8	0.7	1.5	1000	28.8	20.7	0.72	2.30	36.7	12.5	1000	38.2	2.43	29.9	105	4.60
	5.6	1.4	3.3	750	28.5	18.5	0.65	2.07	35.5	13.7	750	39.0	2.75	29.5	118	4.15
	5.6	1.4	3.3	1000	29.6	21.0	0.71	2.16	37.0	13.7	1000	40.0	2.47	31.5	107	4.74
	7.5	2.7	6.3	750	29.0	18.7	0.65	2.00	35.8	14.5	750	40.2	2.78	30.6	120	4.24
	7.5	2.7	6.3	1000	30.2	21.2	0.70	2.08	37.3	14.5	1000	41.2	2.50	32.6	108	4.84
85	3.8	0.6	1.4	750	26.7	17.8	0.67	2.34	34.7	11.5	750	38.8	2.75	29.3	118	4.14
	3.8	0.6	1.4	1000	27.8	20.1	0.72	2.43	36.1	11.5	1000	39.8	2.50	31.3	107	4.72
	5.6	1.4	3.2	750	27.6	18.2	0.66	2.18	35.1	12.7	750	40.5	2.80	30.8	120	4.24
	5.6	1.4	3.2	1000	28.8	20.6	0.71	2.27	36.5	12.7	1000	41.5	2.50	32.9	108	4.84
	7.5	2.7	6.2	750	28.2	18.4	0.65	2.11	35.4	13.4	750	41.6	2.80	31.7	121	4.30
	7.5	2.7	6.2	1000	29.3	20.8	0.71	2.20	36.8	13.4	1000	42.6	2.50	33.9	109	4.91
90	3.8	0.6	1.4	750	25.7	17.3	0.67	2.46	34.1	10.5	750	40.3	2.79	30.6	120	4.23
	3.8	0.6	1.4	1000	26.8	19.6	0.73	2.56	35.5	10.5	1000	41.3	2.51	32.7	108	4.83
	5.6	1.4	3.1	750	26.8	17.8	0.66	2.30	34.7	11.7	750	42.0	2.85	32.1	122	4.33
	5.6	1.4	3.1	1000	27.9	20.1	0.72	2.39	36.1	11.7	1000	43.0	2.56	34.3	110	4.93
	7.5	2.6	6.0	750	27.3	18.0	0.66	2.22	34.9	12.3	750	42.9	2.88	32.9	123	4.36
	7.5	2.6	6.0	1000	28.5	20.4	0.72	2.31	36.4	12.3	1000	44.0	2.59	35.1	111	4.98
100	3.8	0.6	1.3	750	24.0	16.6	0.69	2.74	33.3	8.7	Operation Not Recommended					
	3.8	0.6	1.3	1000	24.9	18.8	0.75	2.85	34.7	8.7						
	5.6	1.3	3.0	750	25.1	17.0	0.68	2.56	33.8	9.8						
	5.6	1.3	3.0	1000	26.1	19.3	0.74	2.67	35.2	9.8						
	7.5	2.5	5.7	750	25.6	17.3	0.67	2.48	34.1	10.3						
	7.5	2.5	5.7	1000	26.7	19.6	0.73	2.58	35.5	10.3						
110	3.8	0.5	1.2	750	22.5	16.1	0.72	3.07	33.0	7.4						
	3.8	0.5	1.2	1000	23.5	18.2	0.78	3.19	34.4	7.4						
	5.6	1.2	2.8	750	23.2	16.3	0.70	2.86	33.1	8.1						
	5.6	1.2	2.8	1000	24.2	18.4	0.76	2.98	34.4	8.1						
	7.5	2.4	5.5	750	23.8	16.5	0.69	2.77	33.3	8.6						
	7.5	2.4	5.5	1000	24.8	18.7	0.75	2.88	34.6	8.6						
120	3.8	0.5	1.1	750	20.4	15.2	0.74	3.44	32.2	5.9						
	3.8	0.5	1.1	1000	21.2	17.2	0.81	3.58	33.5	5.9						
	5.6	1.2	2.7	750	21.4	15.6	0.73	3.21	32.4	6.7						
	5.6	1.2	2.7	1000	22.3	17.6	0.79	3.34	33.8	6.7						
	7.5	2.3	5.3	750	22.0	15.8	0.72	3.10	32.6	7.1						
	7.5	2.3	5.3	1000	22.9	17.8	0.78	3.23	33.9	7.1						

LEGEND

- AHRI — Air Conditioning, Heating, and Refrigeration Institute
- COP — Coefficient of Performance
- db — Dry Bulb
- EAT — Entering Air Temperature
- EER — Energy Efficiency Ratio
- EWT — Entering Water Temperature
- GPM — Gallons Per Minute
- HE — Heat of Extraction (MBtuh)
- ISO — International Organization for Standardization
- LAT — Leaving Air Temperature (F)
- MBtuh — Btuh in Thousands
- TC — Total Capacity (MBtuh)
- THC — Total Heating Capacity (MBtuh)
- THR — Total Heat Rejection (MBtuh)
- TSC — Total Sensible Capacity (MBtuh)
- wb — Wet Bulb

*Performance capacities shown in thousands of Btuh.

NOTES:

1. Interpolation is permissible; extrapolation is not.
2. All entering air conditions are 80 F db and 67 F wb in cooling, and 70 F db in heating. AHRI/ISO certified conditions are 80.6 F db and 66.2 F wb in cooling and 68 F db in heating.
3. Table does not reflect fan or pump power corrections for AHRI/ISO conditions.
4. All performance is based upon the lower voltage of dual voltage rated units.
5. Operation below 40 F EWT is based upon a 15% methanol antifreeze solution.
6. Operation below 60 F EWT requires optional insulated water/refrigerant circuit.
7. See performance correction tables for operating conditions other than those listed above.



50P1H,P1V036

1,200 CFM NOMINAL AIRFLOW COOLING/1,200 CFM NOMINAL AIRFLOW HEATING*

EWT (F)	GPM	PRESSURE DROP		COOLING — EAT 80/67 F							HEATING — EAT 70 F					
		PSI	ft wg	Airflow CFM	TC	TSC	Sens/Tot Ratio	kW	THR	EER	Airflow CFM	THC	kW	HE	LAT	COP
20	9.0	6.4	14.8	Operation Not Recommended							860	22.6	2.67	14.1	94	2.49
	9.0	6.4	14.8	Operation Not Recommended							1150	23.2	2.39	15.1	89	2.84
30	4.5	1.8	4.3	860	39.9	24.2	0.61	1.67	45.6	23.8	860	25.6	2.80	16.6	98	2.68
	4.5	1.8	4.3	1150	41.5	27.4	0.66	1.74	47.4	23.8	1150	26.2	2.51	17.7	91	3.06
	6.8	3.1	7.1	860	40.1	24.3	0.61	1.62	45.5	24.7	860	26.8	2.85	17.6	99	2.76
	6.8	3.1	7.1	1150	41.7	27.5	0.66	1.69	47.4	24.7	1150	27.5	2.56	18.8	92	3.15
	9.0	5.4	12.5	860	40.0	24.3	0.61	1.60	45.5	25.0	860	27.5	2.88	18.2	100	2.80
	9.0	5.4	12.5	1150	41.7	27.5	0.66	1.67	47.3	25.0	1150	28.2	2.59	19.4	93	3.19
40	4.5	1.6	3.6	860	39.2	24.0	0.61	1.80	45.3	21.8	860	30.1	2.98	20.3	102	2.95
	4.5	1.6	3.6	1150	40.8	27.2	0.67	1.87	47.1	21.8	1150	30.8	2.68	21.7	95	3.37
	6.8	2.7	6.2	860	39.7	24.2	0.61	1.71	45.5	23.3	860	31.6	3.05	21.6	104	3.04
	6.8	2.7	6.2	1150	41.4	27.4	0.66	1.78	47.4	23.3	1150	32.4	2.74	23.1	96	3.47
	9.0	4.8	11.1	860	39.9	24.3	0.61	1.67	45.6	23.9	860	32.4	3.08	22.3	105	3.09
	9.0	4.8	11.1	1150	41.6	27.4	0.66	1.74	47.4	23.9	1150	33.2	2.77	23.8	97	3.52
50	4.5	1.4	3.2	860	38.0	23.6	0.62	1.98	44.7	19.2	860	34.5	3.16	24.1	107	3.20
	4.5	1.4	3.2	1150	39.5	26.7	0.68	2.06	46.5	19.2	1150	35.4	2.84	25.7	98	3.65
	6.8	2.4	5.6	860	38.8	23.9	0.62	1.85	45.1	21.0	860	36.3	3.23	25.6	109	3.30
	6.8	2.4	5.6	1150	40.4	27.0	0.67	1.92	47.0	21.0	1150	37.2	2.90	27.3	100	3.76
	9.0	4.4	10.1	860	39.2	24.0	0.61	1.79	45.3	21.9	860	37.3	3.27	26.4	110	3.35
	9.0	4.4	10.1	1150	40.8	27.2	0.67	1.87	47.2	21.9	1150	38.2	2.93	28.2	101	3.82
60	4.5	1.3	2.9	860	36.1	22.9	0.63	2.20	43.6	16.4	860	38.9	3.32	27.8	112	3.43
	4.5	1.3	2.9	1150	37.6	25.9	0.69	2.29	45.4	16.4	1150	39.8	2.99	29.7	102	3.91
	6.8	2.3	5.2	860	37.5	23.5	0.63	2.04	44.4	18.4	860	40.9	3.40	29.5	114	3.53
	6.8	2.3	5.2	1150	39.1	26.5	0.68	2.13	46.3	18.4	1150	41.9	3.05	31.5	104	4.02
	9.0	4.0	9.3	860	38.0	23.6	0.62	1.97	44.7	19.3	860	42.0	3.44	30.4	115	3.58
	9.0	4.0	9.3	1150	39.6	26.7	0.68	2.05	46.5	19.3	1150	43.0	3.09	32.5	105	4.08
70	4.5	1.2	2.7	860	34.6	22.5	0.65	2.46	42.9	14.0	860	43.1	3.47	31.4	116	3.64
	4.5	1.2	2.7	1150	36.0	25.5	0.71	2.56	44.7	14.0	1150	44.1	3.12	33.5	106	4.15
	6.8	2.1	4.9	860	35.8	22.9	0.64	2.28	43.6	15.7	860	45.2	3.55	33.2	119	3.74
	6.8	2.1	4.9	1150	37.3	25.9	0.70	2.38	45.4	15.7	1150	46.3	3.19	35.4	107	4.26
	9.0	3.8	8.7	860	36.4	23.1	0.63	2.20	43.9	16.6	860	46.4	3.59	34.2	120	3.79
	9.0	3.8	8.7	1150	37.9	26.1	0.69	2.29	45.7	16.6	1150	47.5	3.22	36.5	108	4.32
80	4.5	1.1	2.5	860	32.5	21.8	0.67	2.76	41.9	11.8	860	47.0	3.61	34.8	121	3.82
	4.5	1.1	2.5	1150	33.8	24.7	0.73	2.88	43.7	11.8	1150	48.2	3.24	37.1	109	4.36
	6.8	2.0	4.6	860	33.9	22.3	0.66	2.56	42.6	13.2	860	49.2	3.68	36.6	123	3.92
	6.8	2.0	4.6	1150	35.3	25.2	0.72	2.67	44.4	13.2	1150	50.4	3.30	39.1	111	4.47
	9.0	3.6	8.3	860	34.5	22.5	0.65	2.47	42.9	14.0	860	50.3	3.71	37.6	124	3.97
	9.0	3.6	8.3	1150	35.9	25.5	0.71	2.57	44.7	14.0	1150	51.5	3.34	40.1	111	4.53
85	4.5	1.0	2.4	860	31.5	21.5	0.68	2.90	41.5	10.8	860	48.8	3.67	36.3	123	3.90
	4.5	1.0	2.4	1150	32.8	24.4	0.74	3.05	43.3	10.8	1150	50.0	3.29	38.8	110	4.45
	6.8	1.9	4.4	860	32.8	21.9	0.67	2.72	42.1	12.1	860	50.9	3.73	38.1	125	4.00
	6.8	1.9	4.4	1150	34.1	24.8	0.73	2.84	43.8	12.1	1150	52.2	3.35	40.7	112	4.56
	9.0	3.5	8.1	860	33.4	22.1	0.66	2.62	42.3	12.8	860	52.0	3.76	39.0	126	4.05
	9.0	3.5	8.1	1150	34.7	25.0	0.72	2.73	44.1	12.8	1150	53.2	3.38	41.7	113	4.62
90	4.5	1.0	2.3	860	30.5	21.2	0.70	3.10	41.1	9.8	860	50.6	3.72	37.9	125	3.99
	4.5	1.0	2.3	1150	31.8	24.0	0.76	3.23	42.8	9.8	1150	51.9	3.34	40.4	112	4.54
	6.8	1.9	4.3	860	31.7	21.6	0.68	2.88	41.6	11.0	860	52.7	3.79	39.6	127	4.08
	6.8	1.9	4.3	1150	33.0	24.4	0.74	3.00	43.3	11.0	1150	54.0	3.40	42.3	113	4.65
	9.0	3.4	7.9	860	32.2	21.7	0.67	2.78	41.7	11.6	860	53.7	3.82	40.5	128	4.12
	9.0	3.4	7.9	1150	33.5	24.5	0.73	2.89	43.4	11.6	1150	55.0	3.43	43.2	114	4.70
100	4.5	0.9	2.2	860	28.3	20.5	0.72	3.47	40.2	8.1	Operation Not Recommended					
	4.5	0.9	2.2	1150	29.5	23.1	0.79	3.62	41.9	8.2						
	6.8	1.8	4.1	860	29.5	20.8	0.71	3.24	40.6	9.1						
	6.8	1.8	4.1	1150	30.7	23.5	0.77	3.37	42.2	9.1						
	9.0	3.3	7.5	860	30.1	21.0	0.70	3.13	40.8	9.6						
	9.0	3.3	7.5	1150	31.3	23.7	0.76	3.25	42.5	9.6						
110	4.5	0.9	2.1	860	26.2	19.8	0.75	3.88	39.5	6.8						
	4.5	0.9	2.1	1150	27.3	22.4	0.82	4.04	41.1	6.8						
	6.8	1.7	4.0	860	27.2	20.0	0.73	3.63	39.7	7.5						
	6.8	1.7	4.0	1150	28.4	22.6	0.80	3.78	41.3	7.5						
	9.0	3.1	7.2	860	27.6	20.0	0.72	3.51	39.6	7.9						
	9.0	3.1	7.2	1150	28.8	22.7	0.79	3.65	41.3	7.9						
120	4.5	0.9	2.0	860	24.1	19.0	0.79	4.31	38.9	5.6						
	4.5	0.9	2.0	1150	25.1	21.4	0.86	4.49	40.4	5.6						
	6.8	1.6	3.8	860	25.1	19.2	0.77	4.05	39.0	6.2						
	6.8	1.6	3.8	1150	26.1	21.8	0.83	4.21	40.6	6.2						
	9.0	3.0	7.0	860	25.4	19.2	0.76	3.92	38.9	6.5						
	9.0	3.0	7.0	1150	26.5	21.8	0.82	4.08	40.5	6.5						

LEGEND

- AHRI — Air Conditioning, Heating, and Refrigeration Institute
- COP — Coefficient of Performance
- db — Dry Bulb
- EAT — Entering Air Temperature
- EER — Energy Efficiency Ratio
- EWT — Entering Water Temperature
- GPM — Gallons Per Minute
- HE — Heat of Extraction (MBtuh)
- ISO — International Organization for Standardization
- LAT — Leaving Air Temperature (F)
- MBtuh — Btuh in Thousands
- TC — Total Capacity (MBtuh)
- THC — Total Heating Capacity (MBtuh)
- THR — Total Heat Rejection (MBtuh)
- TSC — Total Sensible Capacity (MBtuh)
- wb — Wet Bulb

*Performance capacities shown in thousands of Btuh.

NOTES:

1. Interpolation is permissible; extrapolation is not.
2. All entering air conditions are 80 F db and 67 F wb in cooling, and 70 F db in heating. AHRI/ISO certified conditions are 80.6 F db and 66.2 F wb in cooling and 68 F db in heating.
3. Table does not reflect fan or pump power corrections for AHRI/ISO conditions.
4. All performance is based upon the lower voltage of dual voltage rated units.
5. Operation below 40 F EWT is based upon a 15% methanol antifreeze solution.
6. Operation below 60 F EWT requires optional insulated water/refrigerant circuit.
7. See performance correction tables for operating conditions other than those listed above.

Performance data (cont)



50P1H,P1V042

1,350 CFM NOMINAL AIRFLOW COOLING/1,350 CFM NOMINAL AIRFLOW HEATING*

EWT (F)	GPM	PRESSURE DROP		COOLING — EAT 80/67 F							HEATING — EAT 70 F					
		PSI	ft wg	Airflow CFM	TC	TSC	Sens/Tot Ratio	kW	THR	EER	Airflow CFM	THC	kW	HE	LAT	COP
20	10.5	9.2	21.3	Operation Not Recommended							1050	28.8	3.37	18.1	95	2.51
	10.5	9.2	21.3	1400							1400	29.5	3.03	19.3	90	2.86
30	5.3	2.3	5.3	1050	47.4	30.6	0.65	1.87	53.7	25.4	1050	31.6	3.45	20.5	98	2.68
	5.3	2.3	5.3	1400	49.3	34.7	0.70	1.95	55.9	25.4	1400	32.4	3.10	21.9	91	3.06
	7.9	4.3	10.0	1050	48.4	31.1	0.64	1.76	54.4	27.5	1050	32.9	3.49	21.6	99	2.76
	7.9	4.3	10.0	1400	50.4	35.2	0.70	1.83	56.6	27.5	1400	33.7	3.14	23.1	92	3.15
	10.5	7.9	18.2	1050	48.9	31.3	0.64	1.71	54.7	28.6	1050	33.6	3.52	22.3	100	2.80
	10.5	7.9	18.2	1400	50.9	35.5	0.70	1.78	57.0	28.6	1400	34.5	3.16	23.8	93	3.20
40	5.3	2.0	4.6	1050	45.9	29.9	0.65	2.05	52.8	22.4	1050	36.1	3.59	24.4	102	2.95
	5.3	2.0	4.6	1400	47.8	33.9	0.71	2.13	55.0	22.4	1400	37.0	3.23	26.1	94	3.36
	7.9	3.9	8.9	1050	47.0	30.4	0.65	1.92	53.4	24.5	1050	37.8	3.64	25.8	103	3.04
	7.9	3.9	8.9	1400	48.9	34.4	0.70	2.00	55.6	24.5	1400	38.7	3.27	27.6	96	3.46
	10.5	7.1	16.4	1050	47.5	30.7	0.65	1.86	53.8	25.5	1050	38.7	3.67	26.6	104	3.09
	10.5	7.1	16.4	1400	49.4	34.7	0.70	1.94	56.0	25.5	1400	39.6	3.30	28.4	96	3.52
50	5.3	1.8	4.1	1050	44.4	29.2	0.66	2.26	52.0	19.6	1050	40.8	3.74	28.5	106	3.20
	5.3	1.8	4.1	1400	46.2	33.1	0.72	2.35	54.2	19.6	1400	41.8	3.36	30.4	98	3.65
	7.9	3.5	8.1	1050	45.4	29.7	0.65	2.11	52.6	21.5	1050	42.8	3.80	30.2	108	3.30
	7.9	3.5	8.1	1400	47.3	33.6	0.71	2.20	54.8	21.5	1400	43.8	3.41	32.2	99	3.76
	10.5	6.5	15.0	1050	46.0	30.0	0.65	2.04	52.9	22.5	1050	43.9	3.83	31.1	109	3.35
	10.5	6.5	15.0	1400	47.9	33.9	0.71	2.12	55.1	22.5	1400	44.9	3.44	33.2	100	3.82
60	5.3	1.6	3.7	1050	43.1	28.8	0.67	2.51	51.7	17.2	1050	45.6	3.89	32.6	110	3.44
	5.3	1.6	3.7	1400	44.9	32.6	0.73	2.61	53.8	17.2	1400	46.7	3.49	34.8	101	3.92
	7.9	3.3	7.5	1050	43.9	29.0	0.66	2.34	51.8	18.8	1050	47.8	3.96	34.5	112	3.54
	7.9	3.3	7.5	1400	45.7	32.8	0.72	2.43	53.9	18.8	1400	49.0	3.56	36.9	102	4.04
	10.5	6.1	14.0	1050	44.4	29.2	0.66	2.25	52.1	19.7	1050	49.0	4.00	35.6	113	3.60
	10.5	6.1	14.0	1400	46.2	33.1	0.72	2.35	54.2	19.7	1400	50.2	3.59	38.0	103	4.10
70	5.3	1.5	3.4	1050	41.3	28.1	0.68	2.80	50.9	14.8	1050	50.3	4.04	36.7	114	3.65
	5.3	1.5	3.4	1400	43.0	31.8	0.74	2.91	52.9	14.8	1400	51.5	3.63	39.2	104	4.16
	7.9	3.1	7.1	1050	42.2	28.3	0.67	2.60	51.0	16.2	1050	52.8	4.11	38.8	117	3.76
	7.9	3.1	7.1	1400	43.9	32.0	0.73	2.71	53.1	16.2	1400	54.1	3.70	41.5	106	4.29
	10.5	5.7	13.2	1050	42.8	28.5	0.67	2.51	51.3	17.1	1050	54.1	4.16	40.0	118	3.82
	10.5	5.7	13.2	1400	44.5	32.3	0.73	2.61	53.4	17.1	1400	55.4	3.73	42.7	107	4.35
80	5.3	1.4	3.2	1050	39.5	27.4	0.70	3.13	50.1	12.6	1050	54.9	4.18	40.7	118	3.85
	5.3	1.4	3.2	1400	41.1	31.0	0.76	3.26	52.2	12.6	1400	56.3	3.76	43.4	107	4.39
	7.9	2.9	6.7	1050	40.4	27.6	0.68	2.91	50.3	13.9	1050	57.6	4.27	43.0	121	3.96
	7.9	2.9	6.7	1400	42.1	31.3	0.74	3.03	52.4	13.9	1400	59.0	3.83	45.9	109	4.51
	10.5	5.4	12.6	1050	41.0	27.9	0.68	2.80	50.6	14.6	1050	59.0	4.31	44.2	122	4.01
	10.5	5.4	12.6	1400	42.7	31.5	0.74	2.92	52.6	14.6	1400	60.4	3.87	47.2	110	4.58
85	5.3	1.3	3.1	1050	38.4	27.1	0.71	3.32	49.8	11.6	1050	57.2	4.25	42.6	120	3.94
	5.3	1.3	3.1	1400	40.0	30.7	0.77	3.46	51.8	11.6	1400	58.6	3.82	45.5	109	4.49
	7.9	2.8	6.5	1050	39.4	27.3	0.69	3.08	50.0	12.8	1050	59.9	4.34	44.9	123	4.05
	7.9	2.8	6.5	1400	41.1	30.9	0.75	3.21	52.0	12.9	1400	61.3	3.89	48.0	111	4.61
	10.5	5.3	12.3	1050	40.1	27.5	0.69	2.97	50.2	13.5	1050	61.3	4.38	46.2	124	4.10
	10.5	5.3	12.3	1400	41.7	31.2	0.75	3.09	52.3	13.6	1400	62.7	3.93	49.3	111	4.68
90	5.3	1.3	3.0	1050	37.4	26.8	0.72	3.51	49.4	10.7	1050	59.4	4.32	44.6	122	4.03
	5.3	1.3	3.0	1400	39.0	30.3	0.78	3.65	51.5	10.7	1400	60.8	3.88	47.6	110	4.59
	7.9	2.8	6.4	1050	38.5	27.0	0.70	3.26	49.6	11.8	1050	62.1	4.40	46.9	125	4.13
	7.9	2.8	6.4	1400	40.1	30.6	0.76	3.39	51.6	11.8	1400	63.6	3.96	50.1	112	4.71
	10.5	5.2	12.0	1050	39.1	27.2	0.70	3.14	49.8	12.5	1050	63.5	4.45	48.1	126	4.19
	10.5	5.2	12.0	1400	40.7	30.8	0.76	3.27	51.9	12.5	1400	65.1	3.99	51.4	113	4.77
100	5.3	1.2	2.8	1050	35.2	26.2	0.74	3.94	48.7	8.9	Operation Not Recommended					
	5.3	1.2	2.8	1400	36.7	29.6	0.81	4.10	50.7	8.9						
	7.9	2.7	6.1	1050	36.4	26.4	0.73	3.66	48.9	9.9						
	7.9	2.7	6.1	1400	37.9	29.9	0.79	3.81	50.9	9.9						
	10.5	5.0	11.6	1050	37.1	26.6	0.72	3.52	49.1	10.5						
	10.5	5.0	11.6	1400	38.6	30.1	0.78	3.67	51.1	10.5						
110	5.3	1.2	2.7	1050	32.8	25.5	0.78	4.41	47.9	7.4	Operation Not Recommended					
	5.3	1.2	2.7	1400	34.2	28.9	0.85	4.60	49.9	7.4						
	7.9	2.6	5.9	1050	34.1	25.7	0.76	4.11	48.1	8.3						
	7.9	2.6	5.9	1400	35.5	29.1	0.82	4.28	50.1	8.3						
	10.5	4.8	11.2	1050	34.8	25.9	0.75	3.96	48.4	8.8						
	10.5	4.8	11.2	1400	36.2	29.4	0.81	4.12	50.4	8.8						
120	5.3	1.1	2.6	1050	30.2	24.8	0.82	4.95	47.1	6.1	Operation Not Recommended					
	5.3	1.1	2.6	1400	31.4	28.0	0.89	5.15	49.1	6.1						
	7.9	2.5	5.7	1050	31.5	25.0	0.79	4.61	47.3	6.8						
	7.9	2.5	5.7	1400	32.8	28.3	0.86	4.80	49.3	6.8						
	10.5	4.7	10.8	1050	32.3	25.3	0.78	4.45	47.6	7.3						
	10.5	4.7	10.8	1400	33.7	28.6	0.85	4.63	49.5	7.3						

LEGEND

- AHRI — Air Conditioning, Heating, and Refrigeration Institute
- COP — Coefficient of Performance
- db — Dry Bulb
- EAT — Entering Air Temperature
- EER — Energy Efficiency Ratio
- EWT — Entering Water Temperature
- GPM — Gallons Per Minute
- HE — Heat of Extraction (MBtuh)
- ISO — International Organization for Standardization
- LAT — Leaving Air Temperature (F)
- MBtuh — Btuh in Thousands
- TC — Total Capacity (MBtuh)
- THC — Total Heating Capacity (MBtuh)
- THR — Total Heat Rejection (MBtuh)
- TSC — Total Sensible Capacity (MBtuh)
- wb — Wet Bulb

*Performance capacities shown in thousands of Btuh.

NOTES:

1. Interpolation is permissible; extrapolation is not.
2. All entering air conditions are 80 F db and 67 F wb in cooling, and 70 F db in heating. AHRI/ISO certified conditions are 80.6 F db and 66.2 F wb in cooling and 68 F db in heating.
3. Table does not reflect fan or pump power corrections for AHRI/ISO conditions.
4. All performance is based upon the lower voltage of dual voltage rated units.
5. Operation below 40 F EWT is based upon a 15% methanol antifreeze solution.
6. Operation below 60 F EWT requires optional insulated water/refrigerant circuit.
7. See performance correction tables for operating conditions other than those listed above.



50P1H,P1V048

1,600 CFM NOMINAL AIRFLOW COOLING/1,600 CFM NOMINAL AIRFLOW HEATING*

EWT (F)	GPM	PRESSURE DROP		COOLING — EAT 80/67 F							HEATING — EAT 70 F					
		PSI	ft wg	Airflow CFM	TC	TSC	Sens/Tot Ratio	kW	THR	EER	Airflow CFM	THC	kW	HE	LAT	COP
20	12.0	6.8	15.6	Operation Not Recommended							1200	30.9	3.54	19.6	94	2.56
	12.0	6.8	15.6	Operation Not Recommended							1600	31.6	3.18	20.9	88	2.92
30	6.0	1.8	4.1	1200	56.4	34.4	0.61	2.25	64.0	25.1	1200	33.9	3.60	22.3	96	2.76
	6.0	1.8	4.1	1600	58.8	39.0	0.66	2.34	66.7	25.1	1600	34.7	3.24	23.8	90	3.14
	9.0	3.4	7.8	1200	57.5	34.6	0.60	2.11	64.6	27.2	1200	34.4	3.63	22.7	97	2.78
	9.0	3.4	7.8	1600	59.8	39.1	0.65	2.20	67.2	27.2	1600	35.3	3.26	24.2	90	3.17
	12.0	6.2	14.3	1200	57.9	34.5	0.60	2.05	64.8	28.2	1200	35.1	3.65	23.3	97	2.82
	12.0	6.2	14.3	1600	60.3	39.1	0.65	2.14	67.5	28.2	1600	36.0	3.27	24.9	91	3.22
40	6.0	1.6	3.7	1200	54.8	34.0	0.62	2.47	63.2	22.2	1200	37.9	3.70	25.8	99	3.00
	6.0	1.6	3.7	1600	57.1	38.5	0.67	2.57	65.8	22.2	1600	38.8	3.33	27.5	92	3.42
	9.0	3.1	7.2	1200	56.0	34.3	0.61	2.31	63.8	24.3	1200	39.5	3.74	27.2	100	3.10
	9.0	3.1	7.2	1600	58.3	38.9	0.67	2.40	66.4	24.3	1600	40.5	3.36	29.1	93	3.53
	12.0	5.8	13.4	1200	56.6	34.5	0.61	2.23	64.1	25.4	1200	40.7	3.76	28.3	101	3.18
	12.0	5.8	13.4	1600	58.9	39.0	0.66	2.32	66.8	25.4	1600	41.7	3.37	30.2	94	3.62
50	6.0	1.5	3.4	1200	52.9	33.3	0.63	2.72	62.1	19.4	1200	43.6	3.81	31.0	104	3.36
	6.0	1.5	3.4	1600	55.1	37.7	0.68	2.83	64.7	19.4	1600	44.7	3.42	33.0	96	3.83
	9.0	3.0	6.8	1200	54.3	33.8	0.62	2.53	62.9	21.4	1200	44.9	3.85	32.1	105	3.42
	9.0	3.0	6.8	1600	56.5	38.3	0.68	2.64	65.5	21.4	1600	46.0	3.46	34.3	97	3.90
	12.0	5.5	12.7	1200	55.0	34.0	0.62	2.45	63.2	22.5	1200	46.0	3.87	33.1	106	3.49
	12.0	5.5	12.7	1600	57.2	38.5	0.67	2.55	65.8	22.5	1600	47.1	3.48	35.3	97	3.98
60	6.0	1.4	3.2	1200	50.7	32.5	0.64	3.02	61.0	16.8	1200	48.2	3.91	35.0	107	3.61
	6.0	1.4	3.2	1600	52.8	36.8	0.70	3.15	63.5	16.8	1600	49.3	3.51	37.4	99	4.11
	9.0	2.8	6.5	1200	52.3	33.1	0.63	2.81	61.8	18.6	1200	50.5	3.96	37.1	109	3.74
	9.0	2.8	6.5	1600	54.5	37.5	0.69	2.92	64.4	18.6	1600	51.8	3.56	39.6	100	4.26
	12.0	5.3	12.2	1200	53.0	33.4	0.63	2.70	62.2	19.6	1200	51.8	3.99	38.3	110	3.81
	12.0	5.3	12.2	1600	55.2	37.8	0.68	2.81	64.8	19.6	1600	53.1	3.58	40.9	101	4.34
70	6.0	1.3	3.0	1200	48.3	31.5	0.65	3.38	59.9	14.3	1200	53.5	4.02	39.8	111	3.90
	6.0	1.3	3.0	1600	50.3	35.7	0.71	3.52	62.3	14.3	1600	54.8	3.61	42.4	102	4.44
	9.0	2.7	6.3	1200	50.0	32.2	0.64	3.13	60.7	16.0	1200	56.2	4.08	42.2	113	4.03
	9.0	2.7	6.3	1600	52.1	36.4	0.70	3.25	63.2	16.0	1600	57.5	3.67	45.0	103	4.60
	12.0	5.1	11.8	1200	50.9	32.5	0.64	3.01	61.1	16.9	1200	57.6	4.12	43.4	114	4.10
	12.0	5.1	11.8	1600	53.0	36.8	0.70	3.13	63.6	16.9	1600	59.0	3.70	46.4	104	4.68
80	6.0	1.3	2.9	1200	45.7	30.5	0.67	3.79	58.6	12.1	1200	58.8	4.14	44.5	115	4.16
	6.0	1.3	2.9	1600	47.6	34.5	0.72	3.94	61.0	12.1	1600	60.2	3.72	47.5	105	4.74
	9.0	2.6	6.1	1200	47.5	31.2	0.66	3.50	59.5	13.6	1200	61.7	4.21	47.1	118	4.29
	9.0	2.6	6.1	1600	49.5	35.3	0.71	3.64	61.9	13.6	1600	63.2	3.78	50.2	107	4.90
	12.0	4.9	11.4	1200	48.4	31.6	0.65	3.37	59.9	14.4	1200	63.3	4.25	48.4	119	4.36
	12.0	4.9	11.4	1600	50.4	35.7	0.71	3.50	62.4	14.4	1600	64.8	3.82	51.7	107	4.97
85	6.0	1.2	2.8	1200	44.3	29.9	0.68	4.02	58.0	11.1	1200	61.3	4.20	46.7	117	4.28
	6.0	1.2	2.8	1600	46.1	33.8	0.73	4.19	60.4	11.1	1600	62.8	3.78	49.9	106	4.88
	9.0	2.6	6.0	1200	46.2	30.6	0.66	3.72	58.8	12.5	1200	64.3	4.28	49.4	120	4.40
	9.0	2.6	6.0	1600	48.1	34.7	0.72	3.87	61.3	12.5	1600	65.9	3.84	52.7	108	5.02
	12.0	4.9	11.3	1200	47.1	31.0	0.66	3.57	59.3	13.2	1200	65.9	4.32	50.7	121	4.47
	12.0	4.9	11.3	1600	49.0	35.1	0.72	3.72	61.7	13.2	1600	67.5	3.88	54.1	109	5.09
90	6.0	1.2	2.8	1200	42.9	29.3	0.68	4.26	57.4	10.1	1200	63.9	4.27	49.0	119	4.39
	6.0	1.2	2.8	1600	44.6	33.2	0.74	4.43	59.8	10.1	1600	65.5	3.83	52.3	108	5.01
	9.0	2.6	5.9	1200	44.8	30.1	0.67	3.93	58.2	11.4	1200	66.9	4.35	51.7	122	4.51
	9.0	2.6	5.9	1600	46.6	34.1	0.73	4.10	60.6	11.4	1600	68.6	3.91	55.1	110	5.14
	12.0	4.8	11.1	1200	45.7	30.5	0.67	3.78	58.6	12.1	1200	68.5	4.39	53.0	123	4.57
	12.0	4.8	11.1	1600	47.6	34.5	0.72	3.94	61.1	12.1	1600	70.2	3.95	56.6	111	5.21
100	6.0	1.2	2.7	1200	39.8	28.2	0.71	4.79	56.2	8.3	Operation Not Recommended					
	6.0	1.2	2.7	1600	41.4	31.9	0.77	4.99	58.5	8.3						
	9.0	2.5	5.8	1200	41.8	28.9	0.69	4.43	57.0	9.4						
	9.0	2.5	5.8	1600	43.5	32.7	0.75	4.62	59.3	9.4						
	12.0	4.7	10.9	1200	42.8	29.3	0.69	4.26	57.4	10.0						
12.0	4.7	10.9	1600	44.6	33.2	0.74	4.44	59.7	10.0							
110	6.0	1.1	2.6	1200	36.5	26.9	0.74	5.40	55.0	6.8						
	6.0	1.1	2.6	1600	38.0	30.4	0.80	5.62	57.3	6.8						
	9.0	2.4	5.6	1200	38.6	27.7	0.72	5.00	55.8	7.7						
	9.0	2.4	5.6	1600	40.2	31.4	0.78	5.21	58.0	7.7						
	12.0	4.6	10.6	1200	39.7	28.1	0.71	4.81	56.1	8.2						
12.0	4.6	10.6	1600	41.3	31.8	0.77	5.01	58.5	8.2							
120	6.0	1.1	2.5	1200	33.0	25.5	0.77	6.09	53.9	5.4						
	6.0	1.1	2.5	1600	34.4	28.9	0.84	6.34	56.1	5.4						
	9.0	2.4	5.5	1200	35.2	26.4	0.75	5.65	54.6	6.2						
	9.0	2.4	5.5	1600	36.7	29.9	0.81	5.88	56.8	6.2						
	12.0	4.5	10.4	1200	36.3	26.8	0.74	5.44	55.0	6.7						
12.0	4.5	10.4	1600	37.8	30.3	0.80	5.66	57.2	6.7							

LEGEND

- AHRI — Air Conditioning, Heating, and Refrigeration Institute
- COP — Coefficient of Performance
- db — Dry Bulb
- EAT — Entering Air Temperature
- EER — Energy Efficiency Ratio
- EWT — Entering Water Temperature
- GPM — Gallons Per Minute
- HE — Heat of Extraction (MBtuh)
- ISO — International Organization for Standardization
- LAT — Leaving Air Temperature (F)
- MBtuh — Btuh in Thousands
- TC — Total Capacity (MBtuh)
- THC — Total Heating Capacity (MBtuh)
- THR — Total Heat Rejection (MBtuh)
- TSC — Total Sensible Capacity (MBtuh)
- wb — Wet Bulb

*Performance capacities shown in thousands of Btuh.

NOTES:

1. Interpolation is permissible; extrapolation is not.
2. All entering air conditions are 80 F db and 67 F wb in cooling, and 70 F db in heating. AHRI/ISO certified conditions are 80.6 F db and 66.2 F wb in cooling and 68 F db in heating.
3. Table does not reflect fan or pump power corrections for AHRI/ISO conditions.
4. All performance is based upon the lower voltage of dual voltage rated units.
5. Operation below 40 F EWT is based upon a 15% methanol antifreeze solution.
6. Operation below 60 F EWT requires optional insulated water/refrigerant circuit.
7. See performance correction tables for operating conditions other than those listed above.

Performance data (cont)



50P1H,P1V060

2,000 CFM NOMINAL AIRFLOW COOLING/2,000 CFM NOMINAL AIRFLOW HEATING*

EWT (F)	GPM	PRESSURE DROP		COOLING — EAT 80/67 F							HEATING — EAT 70 F					
		PSI	ft wg	Airflow CFM	TC	TSC	Sens/Tot Ratio	kW	THR	EER	Airflow CFM	THC	kW	HE	LAT	COP
20	15.0	14.0	32.2	Operation Not Recommended							1460	41.6	4.98	25.8	96	2.45
	15.0	14.0	32.2	Operation Not Recommended							1950	42.6	4.48	27.5	90	2.79
30	7.5	3.4	7.9	1460	68.2	41.6	0.61	3.00	78.3	22.8	1460	45.5	5.08	29.2	99	2.62
	7.5	3.4	7.9	1950	71.0	47.0	0.66	3.12	81.6	22.8	1950	46.6	4.56	31.1	92	2.99
	11.3	6.8	15.8	1460	69.0	41.5	0.60	2.87	78.7	24.0	1460	47.4	5.13	30.9	100	2.71
	11.3	6.8	15.8	1950	71.8	47.0	0.65	2.99	82.0	24.0	1950	48.6	4.61	33.0	93	3.09
	15.0	12.6	29.2	1460	69.3	41.3	0.60	2.82	78.8	24.6	1460	48.5	5.16	31.8	101	2.75
	15.0	12.6	29.2	1950	72.1	46.8	0.65	2.94	82.1	24.6	1950	49.7	4.64	34.0	94	3.14
40	7.5	3.1	7.0	1460	66.6	41.1	0.62	3.21	77.4	20.8	1460	52.2	5.27	35.1	103	2.91
	7.5	3.1	7.0	1950	69.3	46.5	0.67	3.34	80.6	20.8	1950	53.5	4.73	37.5	95	3.31
	11.3	6.3	14.6	1460	67.8	41.5	0.61	3.05	78.1	22.2	1460	54.8	5.34	37.3	105	3.01
	11.3	6.3	14.6	1950	70.6	47.0	0.67	3.18	81.3	22.2	1950	56.1	4.80	39.8	97	3.43
	15.0	11.8	27.2	1460	68.3	41.6	0.61	2.98	78.4	22.9	1460	56.2	5.38	38.5	106	3.06
	15.0	11.8	27.2	1950	71.1	47.0	0.66	3.10	81.6	22.9	1950	57.5	4.83	41.1	97	3.49
50	7.5	2.8	6.4	1460	64.7	40.3	0.62	3.47	76.4	18.7	1460	59.5	5.48	41.4	108	3.18
	7.5	2.8	6.4	1950	67.3	45.6	0.68	3.61	79.6	18.7	1950	60.9	4.92	44.2	99	3.63
	11.3	5.9	13.7	1460	66.0	40.9	0.62	3.28	77.1	20.1	1460	62.6	5.57	44.1	110	3.29
	11.3	5.9	13.7	1950	68.7	46.3	0.67	3.41	80.3	20.1	1950	64.1	5.01	47.1	100	3.75
	15.0	11.1	25.7	1460	66.7	41.2	0.62	3.19	77.5	20.9	1460	64.3	5.63	45.6	111	3.35
	15.0	11.1	25.7	1950	69.4	46.6	0.67	3.32	80.7	20.9	1950	65.9	5.05	48.7	101	3.82
60	7.5	2.6	6.0	1460	62.4	39.3	0.63	3.78	75.3	16.5	1460	66.9	5.70	47.8	112	3.44
	7.5	2.6	6.0	1950	65.0	44.5	0.69	3.93	78.4	16.5	1950	68.5	5.12	51.0	103	3.92
	11.3	5.6	13.0	1460	63.7	39.9	0.63	3.56	75.8	17.9	1460	70.4	5.82	50.9	115	3.55
	11.3	5.6	13.0	1950	66.3	45.1	0.68	3.70	78.9	17.9	1950	72.1	5.22	54.4	104	4.05
	15.0	10.7	24.6	1460	64.2	40.0	0.62	3.45	75.9	18.6	1460	72.4	5.88	52.6	116	3.61
	15.0	10.7	24.6	1950	66.8	45.3	0.68	3.59	79.0	18.6	1950	74.1	5.28	56.2	105	4.12
70	7.5	2.4	5.6	1460	59.6	38.0	0.64	4.15	73.7	14.3	1460	74.2	5.93	54.1	117	3.66
	7.5	2.4	5.6	1950	62.0	43.0	0.69	4.32	76.7	14.3	1950	75.9	5.33	57.8	106	4.18
	11.3	5.4	12.5	1460	61.1	38.6	0.63	3.89	74.3	15.7	1460	78.0	6.05	57.5	119	3.78
	11.3	5.4	12.5	1950	63.6	43.7	0.69	4.05	77.4	15.7	1950	79.9	5.44	61.4	108	4.31
	15.0	10.3	23.7	1460	61.6	38.8	0.63	3.77	74.4	16.3	1460	80.1	6.12	59.2	121	3.84
	15.0	10.3	23.7	1950	64.2	43.9	0.68	3.92	77.5	16.3	1950	82.0	5.50	63.2	109	4.37
80	7.5	2.3	5.4	1460	56.4	36.7	0.65	4.59	72.1	12.3	1460	81.1	6.15	60.1	121	3.86
	7.5	2.3	5.4	1950	58.8	41.5	0.71	4.78	75.1	12.3	1950	83.0	5.52	64.2	109	4.41
	11.3	5.2	12.0	1460	58.1	37.3	0.64	4.29	72.7	13.5	1460	84.9	6.27	63.4	124	3.97
	11.3	5.2	12.0	1950	60.4	42.2	0.70	4.47	75.7	13.5	1950	87.0	5.63	67.7	111	4.52
	15.0	9.9	22.9	1460	58.7	37.5	0.64	4.15	72.8	14.1	1460	86.9	6.33	65.1	125	4.02
	15.0	9.9	22.9	1950	61.1	42.4	0.69	4.32	75.8	14.1	1950	89.0	5.69	69.5	112	4.58
85	7.5	2.3	5.2	1460	54.8	36.1	0.66	4.84	71.3	11.4	1460	84.1	6.25	62.8	123	3.95
	7.5	2.3	5.2	1950	57.0	40.8	0.72	5.04	74.2	11.4	1950	86.2	5.60	67.0	111	4.50
	11.3	5.1	11.8	1460	56.4	36.6	0.65	4.52	71.9	12.5	1460	87.8	6.40	65.9	126	4.04
	11.3	5.1	11.8	1950	58.7	41.4	0.70	4.71	74.8	12.5	1950	89.9	5.70	70.4	113	4.61
	15.0	9.8	22.6	1460	57.1	36.8	0.64	4.37	72.0	13.1	1460	89.6	6.40	67.5	127	4.09
	15.0	9.8	22.6	1950	59.5	41.6	0.70	4.55	75.0	13.1	1950	91.8	5.80	72.0	114	4.66
90	7.5	2.2	5.1	1460	53.1	35.4	0.67	5.09	70.5	10.4	1460	87.2	6.35	65.4	125	4.03
	7.5	2.2	5.1	1950	55.3	40.1	0.73	5.30	73.4	10.4	1950	89.3	5.70	69.9	112	4.59
	11.3	5.0	11.6	1460	54.8	35.9	0.66	4.76	71.0	11.5	1460	90.7	6.45	68.4	128	4.12
	11.3	5.0	11.6	1950	57.1	40.7	0.71	4.95	74.0	11.5	1950	92.9	5.80	73.1	114	4.70
	15.0	9.6	22.2	1460	55.5	36.1	0.65	4.60	71.2	12.1	1460	92.3	6.50	69.8	129	4.16
	15.0	9.6	22.2	1950	57.8	40.9	0.71	4.78	74.1	12.1	1950	94.5	5.84	74.5	115	4.74
100	7.5	2.1	4.9	1460	49.6	34.3	0.69	5.67	69.0	8.8	Operation Not Recommended					
	7.5	2.1	4.9	1950	51.7	38.9	0.75	5.90	71.9	8.8						
	11.3	4.9	11.3	1460	51.4	34.7	0.68	5.29	69.5	9.7						
	11.3	4.9	11.3	1950	53.5	39.3	0.73	5.51	72.3	9.7						
	15.0	9.4	21.7	1460	52.1	34.8	0.67	5.11	69.6	10.2						
	15.0	9.4	21.7	1950	54.2	39.4	0.73	5.32	72.4	10.2						
110	7.5	2.0	4.7	1460	46.6	33.8	0.73	6.33	68.2	7.4	Operation Not Recommended					
	7.5	2.0	4.7	1950	48.5	38.2	0.79	6.59	71.0	7.4						
	11.3	4.8	11.0	1460	47.8	33.6	0.70	5.91	68.0	8.1						
	11.3	4.8	11.0	1950	49.8	38.1	0.76	6.15	70.8	8.1						
	15.0	9.2	21.2	1460	48.6	33.7	0.69	5.71	68.2	8.5						
	15.0	9.2	21.2	1950	50.6	38.2	0.75	5.94	71.0	8.5						
120	7.5	2.0	4.6	1460	43.0	33.1	0.77	7.07	67.2	6.1	Operation Not Recommended					
	7.5	2.0	4.6	1950	44.7	37.5	0.84	7.36	70.0	6.1						
	11.3	4.7	10.7	1460	44.2	32.8	0.74	6.61	66.8	6.7						
	11.3	4.7	10.7	1950	46.0	37.1	0.81	6.88	69.6	6.7						
	15.0	9.0	20.7	1460	44.9	32.7	0.73	6.38	66.8	7.0						
	15.0	9.0	20.7	1950	46.8	37.0	0.79	6.64	69.5	7.0						

LEGEND

- AHRI — Air Conditioning, Heating, and Refrigeration Institute
- COP — Coefficient of Performance
- db — Dry Bulb
- EAT — Entering Air Temperature
- EER — Energy Efficiency Ratio
- EWT — Entering Water Temperature
- GPM — Gallons Per Minute
- HE — Heat of Extraction (MBtuh)
- ISO — International Organization for Standardization
- LAT — Leaving Air Temperature (F)
- MBtuh — Btuh in Thousands
- TC — Total Capacity (MBtuh)
- THC — Total Heating Capacity (MBtuh)
- THR — Total Heat Rejection (MBtuh)
- TSC — Total Sensible Capacity (MBtuh)
- wb — Wet Bulb

*Performance capacities shown in thousands of Btuh.

NOTES:

1. Interpolation is permissible; extrapolation is not.
2. All entering air conditions are 80 F db and 67 F wb in cooling, and 70 F db in heating. AHRI/ISO certified conditions are 80.6 F db and 66.2 F wb in cooling and 68 F db in heating.
3. Table does not reflect fan or pump power corrections for AHRI/ISO conditions.
4. All performance is based upon the lower voltage of dual voltage rated units.
5. Operation below 40 F EWT is based upon a 15% methanol antifreeze solution.
6. Operation below 60 F EWT requires optional insulated water/refrigerant circuit.
7. See performance correction tables for operating conditions other than those listed above.



ENTERING AIR CORRECTION TABLE

HEATING CORRECTIONS			
Ent Air DB (F)	Heating Capacity	Power	Heat of Ext
45	1.0507	0.7802	1.1314
50	1.0327	0.8227	1.0953
55	1.0195	0.8683	1.0646
60	1.0102	0.9168	1.0380
65	1.0033	0.9680	1.0139
68	1.0000	1.0000	1.0000
70	0.9979	1.0218	0.9908
75	0.9928	1.0781	0.9673
80	0.9866	1.1367	0.9419

FULL LOAD COOLING CORRECTIONS 400 CFM PER TON											
Ent Air WB (F)	Total Cooling Capacity	Sensible Cooling Capacity Multipliers — Entering DB (F)								kW	THR
		65	70	75	80	80.6	85	90	95		
50	0.7800	0.9778	*	*	*	*	*	*	*	0.9972	0.8243
55	0.8327	0.8966	1.0556	*	*	*	*	*	*	0.9980	0.8667
60	0.8954	0.7505	0.9184	1.1056	*	*	*	*	*	0.9988	0.9169
65	0.9681	—	0.6778	0.8992	1.1213	1.1480	1.3439	*	*	0.9996	0.9747
66.2	0.9871	—	0.6103	0.8420	1.0698	1.0969	1.2938	*	*	0.9999	0.9897
67	1.0000	—	0.5507	0.7782	1.0000	1.0262	1.2161	1.4266	*	1.0000	1.0000
70	1.0508	—	—	0.6408	0.8856	0.9135	1.1082	1.3087	1.4869	1.0005	1.0403
75	1.1435	—	—	—	0.6085	0.6403	0.8566	1.0663	1.2376	1.0014	1.1135

LEGEND

Ent — Entering THR — Total Heat of Rejection
 Ext — Extraction WB — Wet Bulb
 DB — Dry Bulb

*Sensible capacity equals total capacity.

NOTE: AHRI/ISO/ASHRAE 13256-1 uses entering air conditions of Cooling - 80.6 F DB/ 66.2 F WB, and Heating - 68 F DB/ 59 F WB entering air temperature.

AIRFLOW CORRECTION TABLE

% OF RATED	HEATING			COOLING				
	Heating Capacity	Power	Heat of Ext	Total Capacity	Sensible Capacity	Sensible Capacity Ratio*	kW	THR
75	0.9200	0.9606	0.9605	0.9764	1.1134	0.9368	0.9605	0.8837
81.25	0.9384	0.9691	0.9722	0.9829	1.0789	0.9551	0.9730	0.9130
87.5	0.9548	0.9784	0.9826	0.9889	1.0484	0.9717	0.9837	0.9393
93.75	0.9739	0.9887	0.9919	0.9947	1.0222	0.9867	0.9927	0.9668
100	1.0000	1.0000	1.0000	1.0000	1.0000	1.0000	1.0000	1.0000
106.25	1.0377	1.0122	1.0069	1.0050	0.9820	1.0116	1.0055	1.0434
112.5	1.0915	1.0253	1.0126	1.0096	0.9681	1.0216	1.0093	1.1016
118.75	1.1658	1.0394	1.0171	1.0138	0.9583	1.0299	1.0113	1.1790
125	1.2652	1.0544	1.0204	1.0177	0.9527	1.0365	1.0116	1.2798

LEGEND

Ext — Extraction
 THR — Total Heat of Rejection

*Sensible Capacity Ratio = Sensible Capacity/Total Capacity.

ANTIFREEZE CORRECTION TABLE

ANTIFREEZE TYPE	ANTIFREEZE PERCENTAGE	COOLING			HEATING		WATER PRESSURE DROP, EWT 30 F
		EWT 90 F			EWT 30 F		
		Total Capacity	Sensible Capacity	kW	Heating Capacity	kW	
Water	0	1.000	1.000	1.000	1.000	1.000	1.000
Propylene Glycol	5	0.995	0.995	1.003	0.989	0.997	1.070
	15	0.986	0.986	1.009	0.968	0.990	1.210
	25	0.978	0.978	1.014	0.947	0.983	1.360
Methanol	5	0.997	0.997	1.002	0.989	0.997	1.070
	15	0.990	0.990	1.007	0.968	0.990	1.160
	25	0.982	0.982	1.012	0.949	0.984	1.220
Ethanol	5	0.998	0.998	1.002	0.981	0.994	1.140
	15	0.994	0.994	1.005	0.944	0.983	1.300
	25	0.986	0.986	1.009	0.917	0.974	1.360
Ethylene Glycol	5	0.998	0.998	1.002	0.993	0.998	1.040
	15	0.994	0.994	1.004	0.980	0.994	1.120
	25	0.988	0.988	1.008	0.966	0.990	1.200

LEGEND

EWT — Entering Water Temperature

Performance data (cont)



MOTORIZED WATER VALVE CORRECTIONS

UNIT SIZE 50P1	Cv	MOPD	WPD ADDERS		
			GPM	PSI	FT
006	4.9	150	0.8	0.03	0.06
	4.9	150	1.1	0.05	0.12
	4.9	150	1.5	0.09	0.22
009	4.9	150	1.1	0.05	0.12
	4.9	150	1.7	0.12	0.28
	4.9	150	2.2	0.2	0.47
012	4.9	150	1.5	0.09	0.22
	4.9	150	2.3	0.22	0.51
	4.9	150	3	0.37	0.87
015	4.9	150	1.8	0.13	0.31
	4.9	150	2.6	0.28	0.65
	4.9	150	3.5	0.51	1.18
018	4.9	150	2.3	0.22	0.51
	4.9	150	3.4	0.48	1.11
	4.9	150	4.5	0.84	1.95
024	4.9	150	3	0.37	0.87
	4.9	150	4.5	0.84	1.95
	4.9	150	6	1.5	3.46
030	10.3	150	3.8	0.14	0.31
	10.3	150	5.5	0.29	0.66
	10.3	150	7.5	0.53	1.22
036	10.3	150	4.5	0.19	0.44
	10.3	150	6.8	0.44	1.01
	10.3	150	9	0.76	1.76
042	10.3	150	5.3	0.26	0.61
	10.3	150	7.9	0.59	1.36
	10.3	150	10.5	1.04	2.4
048	10.3	150	6	0.34	0.78
	10.3	150	9	0.76	1.76
	10.3	150	12	1.36	3.14
060	10.3	150	7.5	0.53	1.22
	10.3	150	11.3	1.2	2.78
	10.3	150	15	2.12	4.9

LEGEND

MOPD — Maximum Operating Pressure Drop
WPD — Waterside Pressure Drop



BLOWER PERFORMANCE DATA — STANDARD UNIT

50P1 UNIT SIZE	RATED AIRFLOW (cfm)	MIN CFM	FAN SPEED	AIRFLOW (cfm) AT EXTERNAL STATIC PRESSURE (in. wg)															
				0.00	0.05	0.10	0.15	0.20	0.25	0.30	0.35	0.40	0.45	0.50	0.60	0.70	0.80	0.90	1.00
006	220	150	HIGH			310	300	290	280	270	250	230	210	180					
			MED			260	250	240	230	210	200	190	150						
			LOW			210	200	190	180	160	150								
009	325	225	HIGH			410	400	380	360	350	330	320	300	280					
			MED			390	370	360	340	320	310	290	280	260					
			LOW			340	330	322	310	300	280	260	250						
012	400	300	HIGH			470	460	450	440	430	420	400	390	380	320				
			MED			420	410	400	390	380	370	360	350	340					
			LOW			360	360	350	340	320	320	310	300						
015	525	375	HIGH			745	725	706	696	686	666	637	588	539	451				
			MED	686	676	666	657	647	637	617	608	588	549	510					
			LOW	608	598	588	578	568	559	549	529	510	480	451					
018	600	450	HIGH			745	725	706	696	686	666	637	588	539	451				
			MED	686	676	666	657	647	637	617	608	588	549	510					
			LOW	608	598	588	578	568	559	549	529	510	480	451					
024	800	600	HIGH									950	922	884	827	732	656		
			MED	960	950	941	931	912	893	874	855	836	817	789	732	665			
			LOW	779	770	760	751	741	732	722	713	694	684	665	618				
030	1000	750	HIGH							1102	1074	1045	1017	979	903	798			
			MED	1188	1169	1140	1121	1093	1064	1036	1017	988	960	922	846				
			LOW	1064	1045	1017	998	979	960	931	912	884	855	827	751				
036	1200	900	HIGH	1474	1455	1436	1416	1387	1358	1329	1310	1280	1232	1174	1077	931			
			MED	1174	1164	1106	1106	1096	1096	1086	1077	1067	1038	1009	912				
			LOW	980	980	970	970	960	960	951	951	941	922	902					
042	1350	1050	HIGH	1558	1530	1501	1473	1444	1416	1378	1340	1302	1264	1226	1131				
			MED	1416	1397	1368	1349	1321	1302	1273	1245	1207	1169	1131	1064				
			LOW	1083	1083	1074	1074	1064	1055										
048	1600	1200	HIGH					1881	1853	1815	1767	1710	1653	1596	1416	1216	1216		
			MED	1843	1824	1805	1786	1767	1729	1682	1653	1625	1577	1520	1340				
			LOW	1682	1663	1644	1625	1606	1587	1568	1530	1492	1435	1378	1264				
060	2000	1500	HIGH	2195	2195	2185	2176	2156	2117	2078	2048	2019	1999	1970	1921	1842	1754	1627	
			MED	2009	2009	1999	1980	1950	1931	1901	1882	1852	1823	1793	1744	1676	1588		
			LOW	1813	1813	1803	1793	1774	1764	1744	1725	1695	1666	1637	1568				

LEGEND

ESP — External Static Pressure

NOTES:

1. Shaded areas denote ESP where operation is not recommended.
2. Units factory shipped on medium speed. Other speeds require field selection.
3. All airflow is rated and shown above at the lower voltage if unit is dual voltage rated, e.g., 208 v for 208/230 v units.
4. Only two-speed fan (high and medium) available on 575 v units.
5. Performance stated is at the rated power supply, performance may vary as the power supply varies from the rated.

Performance data (cont)



BLOWER PERFORMANCE DATA HIGH-STATIC UNIT

50P1 UNIT SIZE	RATED AIRFLOW (cfm)	MIN CFM	FAN SPEED	AIRFLOW (cfm) AT EXTERNAL STATIC PRESSURE (in. wg)																		
				0.00	0.05	0.10	0.15	0.20	0.25	0.30	0.35	0.40	0.45	0.50	0.60	0.70	0.80	0.90	1.00			
015	525	375	HS HI			774	764	755	745	735	715	696	676	637	519							
			HS MED	725	706	696	686	676	657	657	647	637	617	588	480							
			HS LOW	647	627	617	608	598	588	578	568	568	559	519								
018	600	450	HS HI			774	764	755	745	735	715	696	676	637	519							
			HS MED	725	706	696	686	676	657	657	647	637	617	588	480							
			HS LOW	647	627	617	608	598	588	578	568	568	559	519								
024	800	600	HS HI									979	903	798	665							
			HS MED								988	960	922	846	713	589						
			HS LOW				979	960	931	912	884	855	827	751	675							
030	1000	750	HS HI										1102	988	874	760	713					
			HS MED								1074	1026	979	884	779	713						
			HS LOW	988	979	960	941	931	912	893	865	836	798	713								
036	1200	900	HS HI									1484	1455	1426	1358	1251	1135	931				
			HS MED	1310	1300	1290	1280	1271	1261	1242	1222	1213	1193	1116	1038	883						
			HS LOW	989	980	980	970	970	960	951	931	922	902									
042	1350	1050	HS HI				1473	1463	1444	1425	1397	1387	1378	1311	1178	1026						
			HS MED	1311	1302	1292	1283	1273	1254	1245	1235	1216	1188	1121	1026							
			HS LOW																			
048	1600	1200	HS HI	1938	1910	1862	1786	1701	1577	1435												
			HS MED	1948	1938	1919	1891	1872	1843	1824	1796	1767	1739	1691	1625	1539	1416	1254				
			HS LOW	1758	1748	1739	1720	1710	1691	1672	1644	1615	1587	1520	1435	1311						
060	2000	1500	HS HI	2352	2342	2332	2323	2313	2293	2274	2254	2225	2195	2156	2087	2019	1940	1852				
			HS MED	2117	2107	2107	2097	2068	2038	2019	1999	1989	1980	1940	1891	1842	1460	1715				
			HS LOW	1891	1882	1882	1872	1862	1852	1852	1842	1833	1813	1793	1764	1715	1666	1588				

LEGEND

ESP — External Static Pressure
HS — High Static

NOTES:

1. Shaded areas denote ESP where operation is not recommended.
2. Units factory shipped on medium speed. Other speeds require field selection.
3. All airflow is rated and shown above at the lower voltage if unit is dual voltage rated, e.g., 208 v for 208/230 v units.
4. Only two-speed fan (high and medium) available on 575 v units.
5. Performance stated is at the rated power supply, performance may vary as the power supply varies from the rated.

Electrical data



ELECTRICAL DATA — 50P1H, P1V UNITS WITH STANDARD PSC MOTOR

50P1 UNIT SIZE	RATED VOLTAGE V-Ph-Hz	VOLTAGE MIN/MAX	COMPRESSOR			FAN MOTOR FLA	TOTAL UNIT FLA	MIN CIRCUIT AMP	MAX FUSE/ HACR BRKR
			RLA	LRA	Qty				
006	208/230-1-60	197/254	3.3	17.7	1	0.40	3.7	4.5	15
	265-1-60	239/292	2.9	13.5	1	0.40	3.3	4.0	15
009	208/230-1-60	197/254	5.6	22.2	1	0.80	6.4	7.8	15
	265-1-60	239/292	3.8	18.8	1	0.70	4.5	5.5	15
→ 012	208/230-1-60	197/254	5.1	32.5	1	0.80	5.9	7.2	15
	265-1-60	239/292	4.0	31.5	1	0.70	4.7	5.7	15
015	208/230-1-60	197/254	6.0	29.0	1	1.00	7.0	8.5	15
	265-1-60	239/292	5.4	28.0	1	0.86	6.3	7.6	15
018	208/230-1-60	197/254	7.2	33.0	1	1.00	8.2	10.0	15
	265-1-60	239/292	5.9	28.0	1	0.86	6.8	8.2	15
024	208/230-1-60	197/254	12.8	58.3	1	1.50	14.3	17.5	30
	265-1-60	239/292	9.6	54.0	1	1.30	10.9	13.3	20
030	208/230-1-60	197/254	14.1	73.0	1	3.00	17.1	20.6	30
	265-1-60	239/292	11.2	60.0	1	2.70	13.9	16.7	25
	208/230-3-60	197/254	8.9	58.0	1	3.00	11.9	14.1	20
	460-3-60	414/506	4.2	28.0	1	1.70	5.9	7.0	15
036	208/230-1-60	197/254	16.7	79.0	1	1.80	18.5	22.7	35
	265-1-60	239/292	13.5	72.0	1	2.00	15.5	18.9	30
	208/230-3-60	197/254	10.4	73.0	1	1.80	12.2	14.8	25
	460-3-60	414/506	5.8	38.0	1	1.24	7.0	8.5	15
042	208/230-1-60	197/254	17.9	112.0	1	3.00	20.9	25.4	40
	208/230-3-60	197/254	13.5	88.0	1	3.00	16.5	19.9	30
	460-3-60	414/506	6.0	44.0	1	1.70	7.7	9.2	15
	575-3-60	518/633	4.9	34.0	1	1.40	6.3	7.5	15
048	208/230-1-60	197/254	21.8	117.0	1	3.40	25.2	30.7	50
	208/230-3-60	197/254	13.7	83.1	1	3.40	17.1	20.5	30
	460-3-60	414/506	6.2	41.0	1	1.80	8.0	9.6	15
	575-3-60	518/633	4.8	33.0	1	1.40	6.2	7.4	15
060	208/230-1-60	197/254	26.3	134.0	1	4.90	31.2	37.8	60
	208/230-3-60	197/254	15.6	110.0	1	4.90	20.5	24.4	40
	460-3-60	414/506	7.8	52.0	1	2.50	10.3	12.3	20
	575-3-60	518/633	5.8	38.9	1	1.90	7.7	9.2	15

LEGEND

BRKR — Breaker
FLA — Full Load Amps
HACR — Heating, Air Conditioning and Refrigeration
LRA — Locked Rotor Amps
RLA — Rated Load Amps

NOTES:

1. HACR circuit breaker in USA only.
2. All fuses Class RK-5.

Electrical data (cont)



ELECTRICAL DATA — 50P1H, P1V UNITS WITH STANDARD PSC MOTOR AND INTERNAL SECONDARY PUMP (SPECIAL ORDER OPTION)

50P1 UNIT SIZE	RATED VOLTAGE V-Ph-Hz	VOLTAGE MIN/MAX	COMPRESSOR			FAN MOTOR FLA	TOTAL UNIT FLA	PUMP FLA	MIN CIRCUIT AMP	MAX FUSE/HACR BRKR
			RLA	LRA	Qty					
006	208/230-1-60	197/254	3.3	17.7	1	0.40	4.1	0.4	4.9	15
	265-1-60	239/292	2.9	13.5	1	0.40	4.0	0.7	4.7	15
009	208/230-1-60	197/254	4.5	22.2	1	0.80	5.7	0.4	6.8	15
	265-1-60	239/292	3.8	18.8	1	0.70	5.2	0.7	6.2	15
012	208/230-1-60	197/254	5.1	32.5	1	0.80	6.7	0.8	8.0	15
	265-1-60	239/292	4.0	31.5	1	0.70	5.4	0.7	6.4	15
015	208/230-1-60	197/254	6.0	29.0	1	1.00	7.4	0.4	8.9	15
	265-1-60	239/292	5.4	28.0	1	0.86	7.0	0.7	8.3	15
018	208/230-1-60	197/254	7.2	33.0	1	1.00	9.0	0.8	10.8	15
	265-1-60	239/292	5.9	28.0	1	0.86	7.5	0.7	8.9	15
024	208/230-1-60	197/254	12.8	58.3	1	1.50	15.1	0.8	18.3	30
	265-1-60	239/292	9.6	54.0	1	1.30	11.6	0.7	14.0	20
030	208/230-1-60	197/254	14.1	73.0	1	3.00	17.9	0.8	21.4	35
	265-1-60	239/292	11.2	60.0	1	2.70	14.6	0.7	17.4	25
	208/230-3-60	197/254	8.9	58.0	1	3.00	12.7	0.8	14.9	20
	460-3-60*	414/506	4.2	28.0	1	1.70	6.6	0.7	7.7	15
036	208/230-1-60	197/254	16.7	79.0	1	1.80	19.3	0.8	23.5	40
	265-1-60	239/292	13.5	72.0	1	2.00	16.2	0.7	19.6	30
	208/230-3-60	197/254	10.4	73.0	1	1.80	13.0	0.8	15.6	25
	460-3-60*	414/506	5.8	38.0	1	1.24	7.7	0.7	9.2	15
042	208/230-1-60	197/254	17.9	112.0	1	3.00	21.7	0.8	26.2	40
	208/230-3-60	197/254	13.5	88.0	1	3.00	17.3	0.8	20.7	30
	460-3-60*	414/506	6.0	44.0	1	1.70	8.4	0.7	9.9	15
048	208/230-1-60	197/254	21.8	117.0	1	3.40	26.3	1.1	31.7	50
	208/230-3-60	197/254	13.7	83.1	1	3.40	18.2	1.1	21.6	35
	460-3-60*	414/506	6.2	41.0	1	1.80	9.1	1.1	10.6	15
060	208/230-1-60	197/254	26.3	134.0	1	4.90	32.3	1.1	38.8	60
	208/230-3-60	197/254	15.6	110.0	1	4.90	21.6	1.1	25.5	40
	460-3-60*	414/506	7.8	52.0	1	2.50	11.4	1.1	13.3	20

LEGEND

BRKR — Breaker
FLA — Full Load Amps
HACR — Heating, Air Conditioning and Refrigeration
LRA — Locked Rotor Amps
RLA — Rated Load Amps

*Neutral connection required. All 460-v units with internal secondary pumps require a 4-wire power supply with neutral. Internal secondary pumps are rated 265 vac and are wired between one hot leg and neutral.

NOTES:

1. HACR circuit breaker in USA only.
2. All fuses Class RK-5.



ELECTRICAL DATA — 50P1H, P1V UNITS WITH HIGH-STATIC PSC MOTOR

50P1 UNIT SIZE	RATED VOLTAGE V-Ph-Hz	VOLTAGE MIN/MAX	COMPRESSOR			FAN MOTOR FLA	TOTAL UNIT FLA	MIN CIRCUIT AMP	MAX FUSE/ HACR
			RLA	LRA	Qty				
015	208/230-1-60	197/254	6.0	29.0	1	1.00	7.0	8.5	15
	265-1-60	239/292	5.4	28.0	1	0.86	6.3	7.6	15
018	208/230-1-60	197/254	7.2	33.0	1	1.50	8.7	10.5	15
	265-1-60	239/292	5.9	28.0	1	1.30	7.2	8.7	15
024	208/230-1-60	197/254	12.8	58.3	1	3.00	15.8	19.0	30
	265-1-60	239/292	9.6	54.0	1	2.70	12.3	14.7	20
030	208/230-1-60	197/254	14.1	73.0	1	3.00	17.1	20.6	30
	265-1-60	239/292	11.2	60.0	1	2.70	13.9	16.7	25
	208/230-3-60	197/254	8.9	58.0	1	3.00	11.9	14.1	20
	460-3-60	414/506	4.2	28.0	1	1.70	5.9	7.0	15
036	208/230-1-60	197/254	16.7	79.0	1	3.00	19.7	23.9	40
	265-1-60	239/292	13.5	72.0	1	2.70	16.2	19.6	30
	208/230-3-60	197/254	10.4	73.0	1	3.00	13.4	16.0	25
	460-3-60	414/506	5.8	38.0	1	1.70	7.5	9.0	15
042	208/230-1-60	197/254	17.9	112.0	1	3.00	20.9	25.4	40
	208/230-3-60	197/254	13.5	88.0	1	3.00	16.5	19.9	30
	460-3-60	414/506	6.0	44.0	1	1.70	7.7	9.2	15
	575-3-60	518/633	4.9	34.0	1	1.40	6.3	7.5	15
048	208/230-1-60	197/254	21.8	117.0	1	4.90	26.7	32.2	50
	208/230-3-60	197/254	13.7	83.1	1	4.90	18.6	22.0	35
	460-3-60	414/506	6.2	41.0	1	2.50	8.7	10.3	15
	575-3-60	518/633	4.8	33.0	1	1.90	6.7	7.9	15
060	208/230-1-60	197/254	26.3	134.0	1	5.80	32.1	38.7	60
	208/230-3-60	197/254	15.6	110.0	1	5.80	21.4	25.3	40
	460-3-60	414/506	7.8	52.0	1	2.60	10.4	12.4	20
	575-3-60	518/633	5.8	38.9	1	2.30	8.1	9.6	15

LEGEND

- BRKR** — Breaker
- FLA** — Full Load Amps
- HACR** — Heating, Air Conditioning and Refrigeration
- LRA** — Locked Rotor Amps
- RLA** — Rated Load Amps

NOTES:

1. HACR circuit breaker in USA only.
2. All fuses Class RK-5.

Electrical data (cont)



ELECTRICAL DATA — 50P1H, P1V UNITS WITH HIGH-STATIC PSC MOTOR AND INTERNAL SECONDARY PUMP (SPECIAL ORDER OPTION)

50P1 UNIT SIZE	RATED VOLTAGE V-Ph-Hz	VOLTAGE MIN/MAX	COMPRESSOR			FAN MOTOR FLA	TOTAL UNIT FLA	PUMP FLA	MIN CIRCUIT AMP	MAX FUSE/HACR BRKR
			RLA	LRA	Qty					
015	208/230-1-60	197/254	6.0	29.0	1	1.00	7.4	0.4	8.9	15
	265-1-60	239/292	5.4	28.0	1	0.86	7.0	0.7	8.3	15
018	208/230-1-60	197/254	7.2	33.0	1	1.50	9.5	0.8	11.3	15
	265-1-60	239/292	5.9	28.0	1	1.30	7.9	0.7	9.4	15
024	208/230-1-60	197/254	12.8	58.3	1	3.00	16.6	0.8	19.8	30
	265-1-60	239/292	9.6	54.0	1	2.70	13.0	0.7	15.4	25
030	208/230-1-60	197/254	14.1	73.0	1	3.00	17.9	0.8	21.4	35
	265-1-60	239/292	11.2	60.0	1	2.70	14.6	0.7	17.4	25
	208/230-3-60	197/254	8.9	58.0	1	3.00	12.7	0.8	14.9	20
	460-3-60*	414/506	4.2	28.0	1	1.70	6.6	0.7	7.7	15
036	208/230-1-60	197/254	16.7	79.0	1	3.00	20.5	0.8	24.7	40
	265-1-60	239/292	13.5	72.0	1	2.70	16.9	0.7	20.3	30
	208/230-3-60	197/254	10.4	73.0	1	3.00	14.2	0.8	16.8	25
	460-3-60*	414/506	5.8	38.0	1	1.70	8.2	0.7	9.7	15
042	208/230-1-60	197/254	17.9	112.0	1	3.00	21.7	0.8	26.2	40
	208/230-3-60	197/254	13.5	88.0	1	3.00	17.3	0.8	20.7	30
	460-3-60*	414/506	6.0	44.0	1	1.70	8.4	0.7	9.9	15
048	208/230-1-60	197/254	21.8	117.0	1	4.90	27.8	1.1	33.2	50
	208/230-3-60	197/254	13.7	83.1	1	4.90	19.7	1.1	23.1	35
	460-3-60*	414/506	6.2	41.0	1	2.50	9.8	1.1	11.3	15
060	208/230-1-60	197/254	26.3	134.0	1	5.80	33.2	1.1	39.7	60
	208/230-3-60	197/254	15.6	110.0	1	5.80	22.5	1.1	26.4	40
	460-3-60*	414/506	7.8	52.0	1	2.60	11.5	1.1	13.4	20

*Neutral connection required. All 460-v units with internal secondary pumps require a 4-wire power supply with neutral. Internal secondary pumps are rated 265 vac and are wired between one hot leg and neutral.

LEGEND

BRKR — Breaker
FLA — Full Load Amps
HACR — Heating, Air Conditioning and Refrigeration
LRA — Locked Rotor Amps
RLA — Rated Load Amps

NOTES:

1. HACR circuit breaker in USA only.
2. All fuses Class RK-5.

Typical piping and wiring



TYPICAL PIPING AND WIRING INSTALLATION

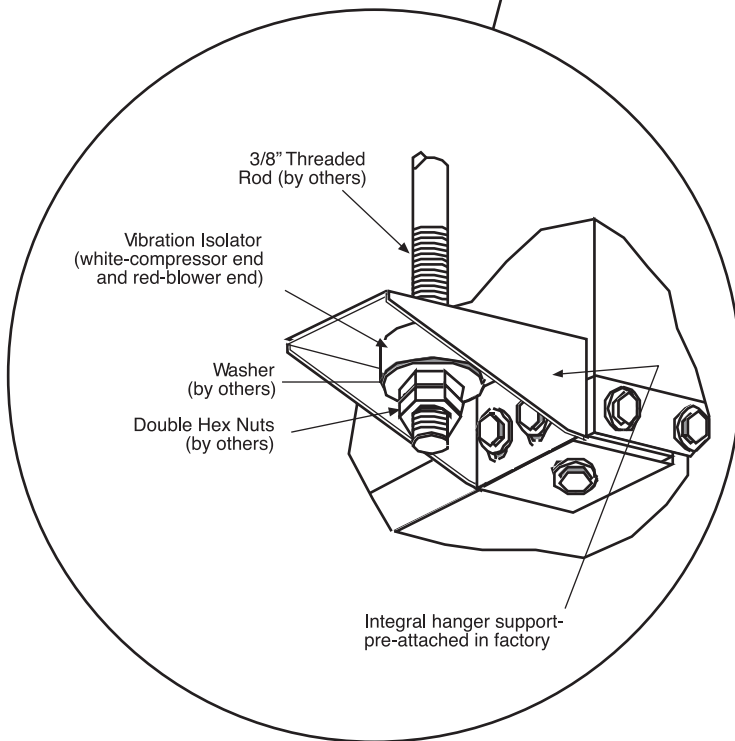
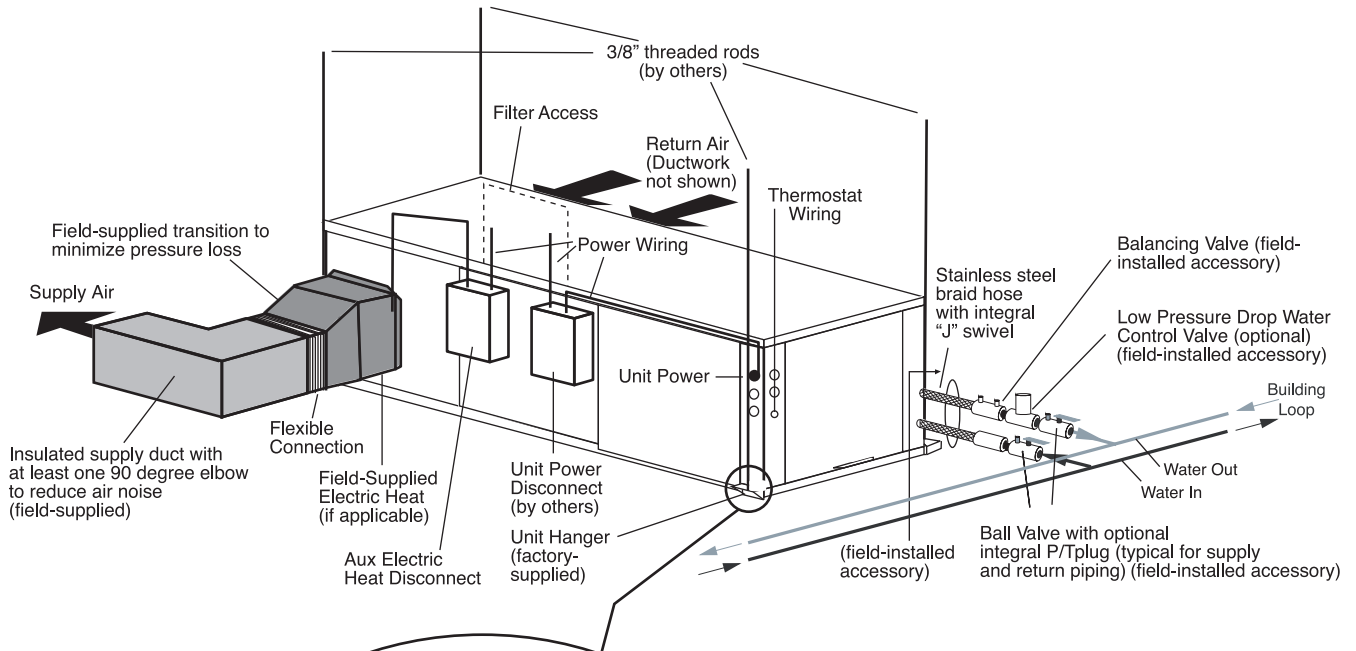

UNIT HANGER ISOLATION DETAIL

Typical control wiring schematics



UNITS WITH COMPLETE C CONTROLLER, SINGLE-PHASE

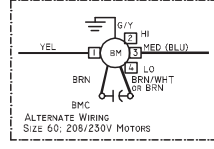
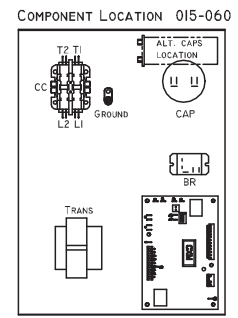
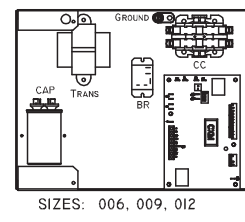
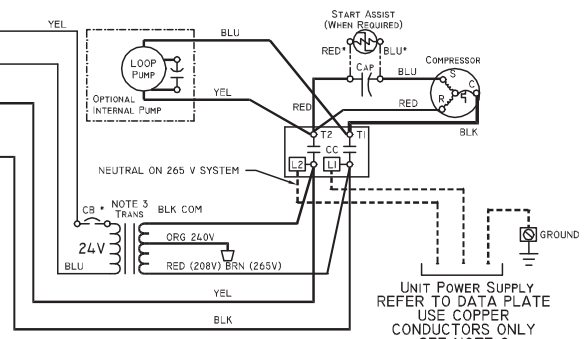
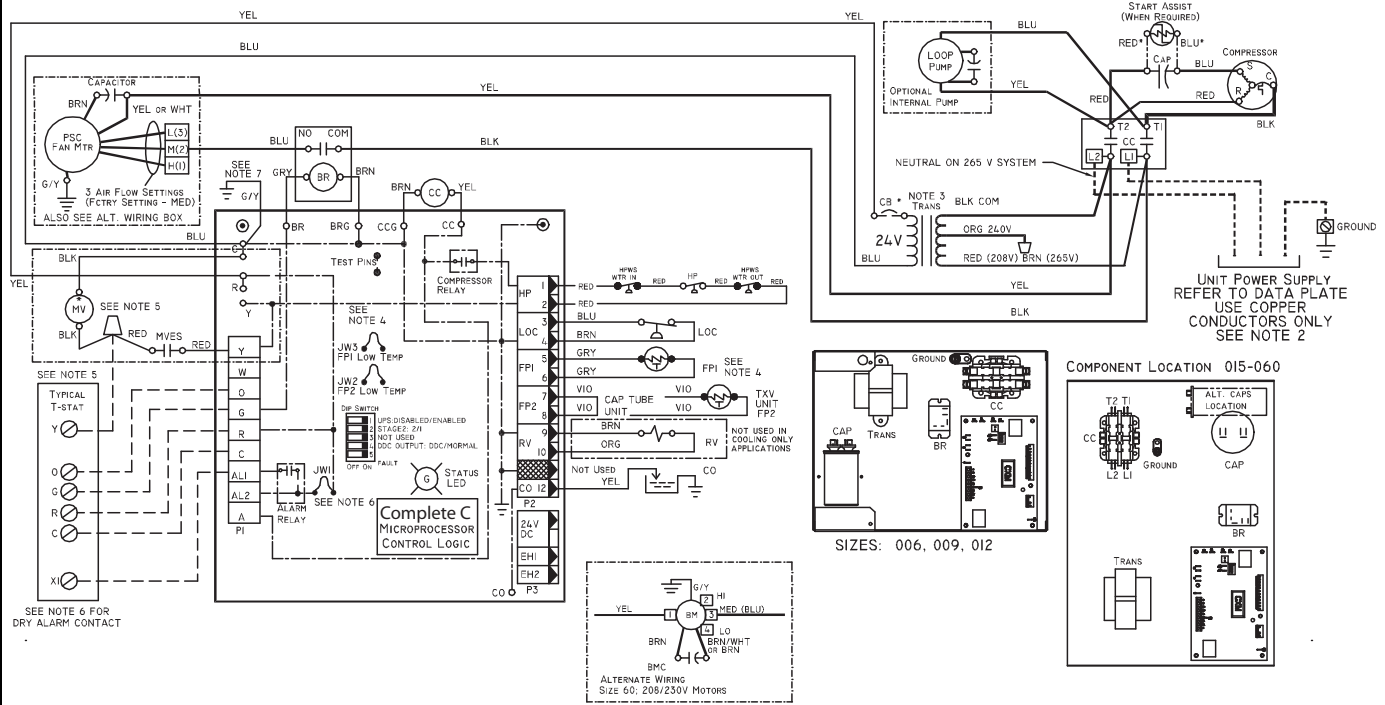

LEGEND

- AL** — Alarm Relay Contacts
- BM** — Blower Motor
- BMC** — Blower Motor Contactor
- BR** — Blower Relay
- CB** — Circuit Breaker
- CC** — Compressor Contactor
- CO** — Condensate Overflow Sensor
- FP1** — Water Coil Freeze Protection Sensor
- FP2** — Air Coil Freeze Protection Sensor
- HP** — High-Pressure Switch
- HPWS** — High Pressure Water Switch
- JW** — Jumper Wire
- LOC** — Loss of Charge Pressure Switch
- MV** — Motorized Valve
- NEC** — National Electrical Code
- PSC** — Permanent Split Capacitor
- P1** — Field Wiring Terminal Block
- RV** — Reversing Valve Solenoid

- TRANS** — Transformer
- TXV** — Thermostatic Expansion Valve
- UPS** — Unit Performance Sentinel
- — Factory Low Voltage Wiring
- — Factory Line Voltage Wiring
- — Field Low Voltage Wiring
- — Field Line Voltage Wiring
- — Printed Circuit Trace
- — Optional Wiring
- — Relay/Contactor Coil
- ⊕ — Thermistor
- — Condensate Pan
- — Circuit Breaker

- ⊕ — Solenoid Coil
- ⊕ — Relay Contacts - N.C.
- ⊕ — Relay Contacts - N.O.
- ⊕ — Capacitor
- ⊕ — Temperature Switch
- ⊕ — Low Pressure Switch
- ⊕ — High Pressure Switch
- ⊕ — Wire Nut
- ⊕ — Splice Cap
- ⊕ — LED

*Optional.

NOTES:

1. Compressor and blower motor thermally protected internally.
2. All wiring to the unit must comply with NEC and local codes.
3. 208/230 v transformer will be connected for 208 v operation. For 230 v operation, disconnect RED lead at L1 and attach ORANGE lead to L1. Insulate open end of RED lead. Transformer is energy limiting or may have circuit breaker.
4. FP1 thermistor provides freeze protection for water. When using anti-freeze solutions, cut JW3 jumper.
5. Check installation wiring information for specific thermostat hookup. Refer to thermostat installation instructions for wiring to the unit. Thermostat wiring must be "Class 1" and voltage rating equal to or greater than unit supply voltage.
6. 24-v alarm signal shown. For dry alarm contact, cut JW1 jumper and dry contact will be available between AL1 and AL2.
7. Transformer secondary ground via Complete C board standoffs and screws to control box. (Ground available from top two standoffs as shown.)
8. Fan motors factory wired for medium speed. For high and low speed remove BLU wire from fan motor speed tap 'M' and connect to 'H' for high or 'L' for low.
9. Aquastat is supplied with unit and must be wired in series with the hot leg to the pump. Aquastat is rated for voltage up to 277 v.

COMPLETE C CONTROLLER FAULT CODES

DESCRIPTION OF OPERATION	LED	ALARM RELAY
Normal Mode	ON	Open
Normal Mode with UPS Warning	ON	Cycle (Closed 5 Sec. Open 25 Sec.)
Complete C is Non-Functional	OFF	Open
Fault Retry	Slow Flash	Open
Lockout	Fast Flash	Closed
Over/Under Voltage Shutdown	Slow Flash	Open (Closed After 15 Min.)
Test Mode-No Fault in Memory	Flashing Code 1	Cycling Code 1
Test Mode-HP Fault in Memory	Flashing Code 2	Cycling Code 2
Test Mode-LP Fault in Memory	Flashing Code 3	Cycling Code 3
Test Mode-FP1 Fault in Memory	Flashing Code 4	Cycling Code 4
Test Mode-FP2 Fault in Memory	Flashing Code 5	Cycling Code 5
Test Mode-CO Fault in Memory	Flashing Code 6	Cycling Code 6
Test Mode-Over/Under Shutdown in Memory	Flashing Code 7	Cycling Code 7
Test Mode-UPS in Memory	Flashing Code 8	Cycling Code 8
Swapped FP1/FP2 Lockout	Flashing Code 9	Cycling Code 9

UNITS WITH COMPLETE C CONTROLLER, 208/230 V, THREE-PHASE UNITS

COMPONENT LOCATION

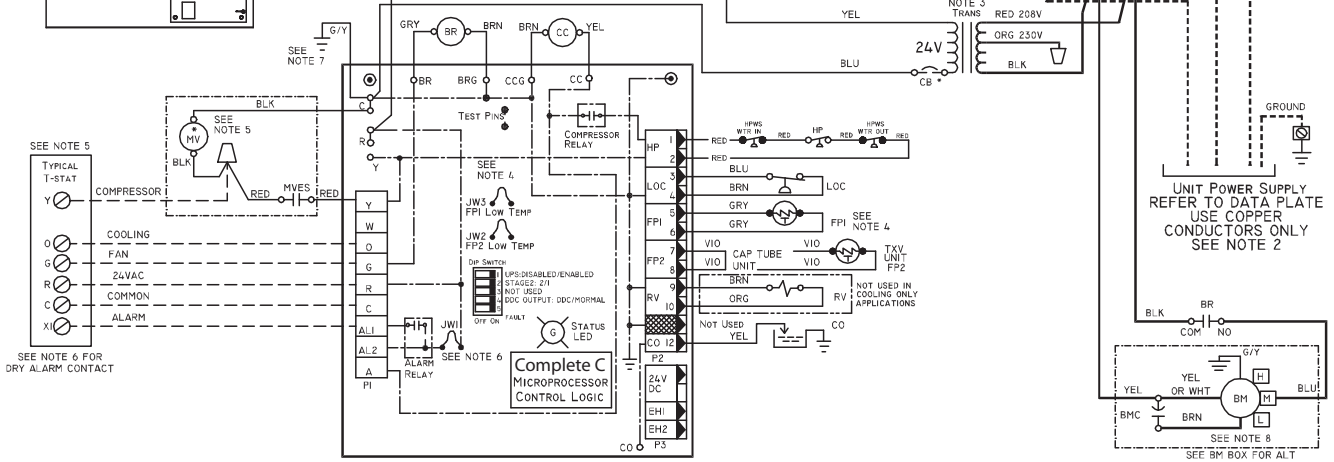
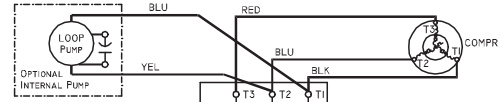
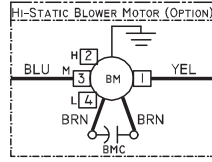
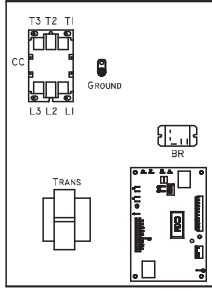

LEGEND

- AL** — Alarm Relay Contacts
- BM** — Blower Motor
- BMC** — Blower Motor Contactor
- BR** — Blower Relay
- CB** — Circuit Breaker
- CC** — Compressor Contactor
- CO** — Condensate Overflow Sensor
- COMPR** — Compressor
- FP1** — Water Coil Freeze Protection Sensor
- FP2** — Air Coil Freeze Protection Sensor
- HP** — High-Pressure Switch
- HPWS** — High Pressure Water Switch
- JW** — Jumper Wire
- LOC** — Loss of Charge Pressure Switch
- MV** — Motorized Valve
- MVES** — Motorized Valve End Switch
- NEC** — National Electrical Code
- P1** — Field Wiring Terminal Block
- RV** — Reversing Valve Solenoid

- TRANS** — Transformer
- TXV** — Thermostatic Expansion Valve
- UPS** — Unit Performance Sentinel
- — Factory Low Voltage Wiring
- — Field Low Voltage Wiring
- — Field Line Voltage Wiring
- — Printed Circuit Trace
- — Optional Wiring
- — Relay/Contactor Coil
- — Thermistor
- — Condensate Pan
- — Circuit Breaker

- — Solenoid Coil
- — Relay Contacts - N.C.
- — Relay Contacts - N.O.
- — Capacitor
- — Temperature Switch
- — Low Pressure Switch
- — High Pressure Switch
- — Wire Nut
- — Splice Cap
- — LED

*Optional.

NOTES:

1. Compressor and blower motor thermally protected internally.
2. All wiring to the unit must comply with NEC and local codes.
3. 208/230 v transformer will be connected for 208 v operation. For 230 v operation, disconnect RED lead at L1 and attach ORANGE lead to L1. Insulate open end of RED lead. Transformer is energy limiting or may have circuit breaker.
4. FP1 thermistor provides freeze protection for water. When using anti-freeze solutions, cut JW3 jumper.
5. Check installation wiring information for specific thermostat hookup. Refer to thermostat installation instructions for wiring to the unit. Thermostat wiring must be "Class 1" and voltage rating equal to or greater than unit supply voltage.
6. 24-v alarm signal shown. For dry alarm contact, cut JW1 jumper and dry contact will be available between AL1 and AL2.
7. Transformer secondary ground via Complete C board standoffs and screws to control box. (Ground available from top two standoffs as shown.)
8. Aquastat is supplied with unit and must be wired in series with the hot leg to the pump. Aquastat is rated for voltage up to 277 v.
9. Fan motors factory wired for medium speed. For high and low speed remove BLU wire from fan motor speed tap 'M' and connect to 'H' for high or 'L' for low.

COMPLETE C CONTROLLER FAULT CODES

DESCRIPTION OF OPERATION	LED	ALARM RELAY
Normal Mode	ON	Open
Normal Mode with UPS Warning	ON	Cycle (Closed 5 Sec. Open 25 Sec.)
Complete C is Non-Functional	OFF	Open
Fault Retry	Slow Flash	Open
Lockout	Fast Flash	Closed
Over/Under Voltage Shutdown	Slow Flash	Open (Closed After 15 Min.)
Test Mode-No Fault in Memory	Flashing Code 1	Cycling Code 1
Test Mode-HP Fault in Memory	Flashing Code 2	Cycling Code 2
Test Mode-LP Fault in Memory	Flashing Code 3	Cycling Code 3
Test Mode-FP1 Fault in Memory	Flashing Code 4	Cycling Code 4
Test Mode-FP2 Fault in Memory	Flashing Code 5	Cycling Code 5
Test Mode-CO Fault in Memory	Flashing Code 6	Cycling Code 6
Test Mode-Over/Under Shutdown in Memory	Flashing Code 7	Cycling Code 7
Test Mode-UPS in Memory	Flashing Code 8	Cycling Code 8
Swapped FP1/FP2 Lockout	Flashing Code 9	Cycling Code 9

Typical control wiring schematics (cont)



UNITS WITH COMPLETE C CONTROLLER, 460 AND 575 V, THREE-PHASE UNITS

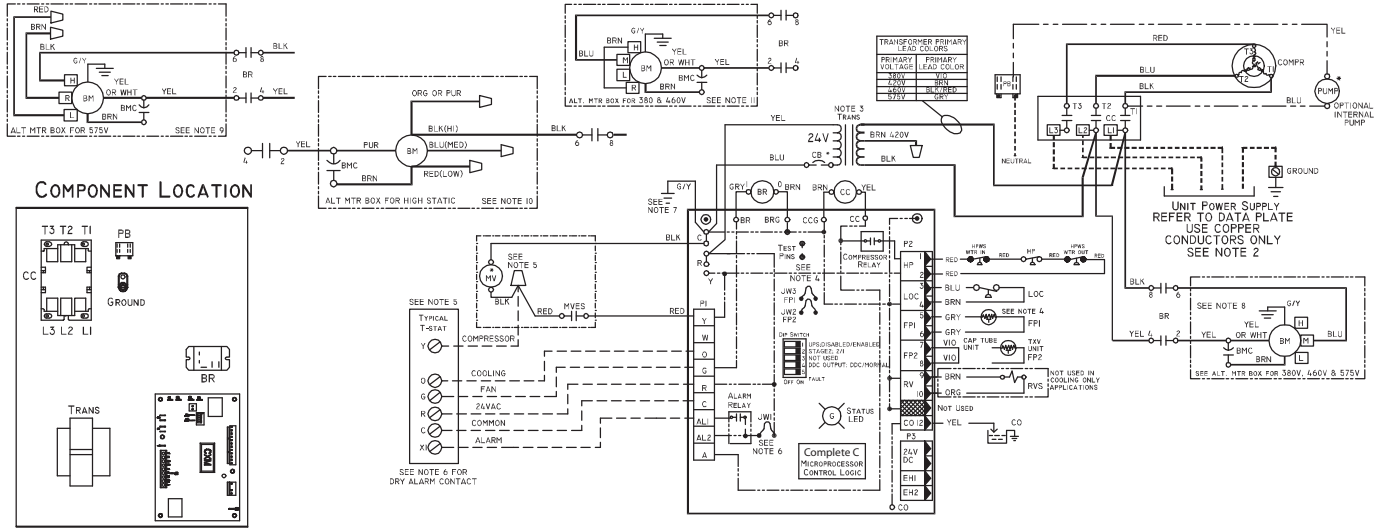

LEGEND

- AL — Alarm Relay Contacts
- BM — Blower Motor
- BMC — Blower Motor Contactor
- BR — Blower Relay
- CB — Circuit Breaker
- CC — Compressor Contactor
- CO — Condensate Overflow Sensor
- COMPR — Compressor
- COV — Water Coil Freeze Protection Sensor
- FP1 — Air Coil Freeze Protection Sensor
- FP2 — High-Pressure Switch
- HP — High-Pressure Water Switch
- HPWS — Jumper Wire
- JW — Loss of Charge Pressure Switch
- LOC — Motorized Valve
- MV — Motorized Valve End Switch
- MVES — National Electrical Code
- NEC — Field Wiring Terminal Block
- P1 — Power Block
- PB — Reversing Valve Solenoid
- RVS —

- TRANS — Transformer
- TXV — Thermostatic Expansion Valve
- UPS — Unit Performance Sentinel
- Factory Low Voltage Wiring
- Factory Line Voltage Wiring
- Field Low Voltage Wiring
- Field Line Voltage Wiring
- Printed Circuit Trace
- Optional Wiring
- Relay/Contactor Coil
- Thermistor
- Condensate Pan
- Circuit Breaker

- Solenoid Coil
- Relay Contacts - N.C.
- Relay Contacts - N.O.
- Capacitor
- Temperature Switch
- Low Pressure Switch
- High Pressure Switch
- Wire Nut
- Splice Cap
- LED

*Optional.

NOTES:

1. Compressor and blower motor thermally protected internally.
2. All wiring to the unit must comply with NEC and local codes.
3. Transformer is wired to 460 v lead (black/red) for 460 v units. Transformer is wired to 575 v lead (grey) for 575 v units. Transformer is energy limiting or may have circuit breaker.
4. FP1 thermistor provides freeze protection for water. When using antifreeze solutions, cut JW3 jumper.
5. Check installation wiring information for specific thermostat hookup. Refer to thermostat installation instructions for wiring to the unit. Thermostat wiring must be "Class 1" and voltage rating equal to or greater than unit supply voltage.
6. 24-v alarm signal shown. For dry alarm contact, cut JW1 jumper and dry contact will be available between AL1 and AL2.
7. Transformer secondary ground via Complete C board standoffs and screws to control box. (Ground available from top two standoffs as shown.)
8. Blower motors factory wired for medium speed. For high and low speed remove BLU wire from fan motor speed tap 'M' and connect to 'H' for high or 'L' for low.
9. For low speed, remove black wire from BR6 and replace with red wire. Connect brown and black wires together.
10. For blower motors with leads, for medium or low speed, disconnect black wire from BR6. Connect black and orange/purple wire together. Connect red for low or blue for medium to BR6.
11. Blower motor factory wired for medium speed. For low speed remove BLU wire from medium speed tap and connect to low speed tap. For high speed remove BLU wire from medium speed tap and connect to high speed tap. Remove brown jumper wire from high speed tap. Insulate open end of brown jumper.

COMPLETE C CONTROLLER FAULT CODES

DESCRIPTION OF OPERATION	LED	ALARM RELAY
Normal Mode	ON	Open
Normal Mode with UPS Warning	ON	Cycle (Closed 5 Sec. Open 25 Sec.)
Complete C is Non-Functional	OFF	Open
Fault Retry	Slow Flash	Open
Lockout	Fast Flash	Closed
Over/Under Voltage Shutdown	Slow Flash	Open (Closed After 15 Min.)
Test Mode-No Fault in Memory	Flashing Code 1	Cycling Code 1
Test Mode-HP Fault in Memory	Flashing Code 2	Cycling Code 2
Test Mode-LP Fault in Memory	Flashing Code 3	Cycling Code 3
Test Mode-FP1 Fault in Memory	Flashing Code 4	Cycling Code 4
Test Mode-FP2 Fault in Memory	Flashing Code 5	Cycling Code 5
Test Mode-CO Fault in Memory	Flashing Code 6	Cycling Code 6
Test Mode-Over/Under Shutdown in Memory	Flashing Code 7	Cycling Code 7
Test Mode-UPS in Memory	Flashing Code 8	Cycling Code 8
Swapped FP1/FP2 Lockout	Flashing Code 9	Cycling Code 9

UNITS WITH DELUXE D CONTROLLER, SINGLE-PHASE

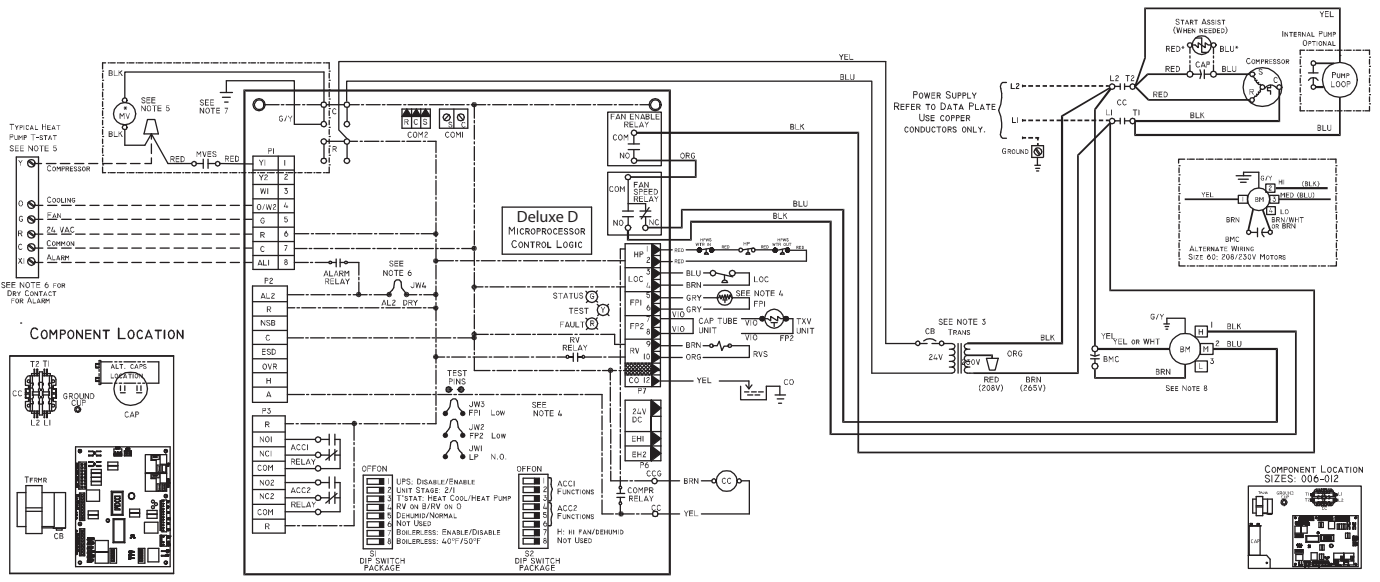

LEGEND

- | | | |
|---|--|--|
| <ul style="list-style-type: none"> AL — Alarm Relay Contacts BM — Blower Motor BMC — Blower Motor Capacitor CB — Circuit Breaker CC — Compressor Contactor CO — Condensate Overflow Sensor FP1 — Water Coil Freeze Protection Sensor FP2 — Air Coil Freeze Protection Sensor HP — High-Pressure Switch HPWS — High Pressure Water Switch JW — Jumper Wire LOC — Loss of Charge Pressure Switch MV — Motorized Valve MVES — Motorized Valve End Switch NEC — National Electric Code P1 — Field Wiring Terminal Block RVS — Reversing Valve Solenoid TRANS — Transformer TXV — Thermostatic Expansion Valve | <ul style="list-style-type: none"> Factory Low Voltage Wiring Factory Line Voltage Wiring Field Low Voltage Wiring Field Line Voltage Wiring Printed Circuit Trace Optional Wiring Relay/Contactor Coil Thermistor Condensate Pan Circuit Breaker Ground | <ul style="list-style-type: none"> Solenoid Coil Relay Contacts - N.C. Relay Contacts - N.O. Capacitor Temperature Switch Low Pressure Switch High Pressure Switch Wire Nut Splice Cap LED |
|---|--|--|

*Optional.

NOTES:

1. Compressor and blower motor thermally protected internally.
2. All wiring to the unit must comply with NEC and local codes.
3. 208/230 v transformer will be connected for 208 v operation. For 230 v operation, disconnect RED lead at L1 and attach ORANGE lead to L1. Insulate open end of RED lead. Transformer is energy limiting or may have circuit breaker.
4. FP1 thermistor provides freeze protection for water. When using antifreeze solutions, cut JW3 jumper.
5. Check installation wiring information for specific thermostat hookup. Refer to thermostat installation instructions for wiring to the unit. Thermostat wiring must be "Class 1" and voltage rating equal to or greater than unit supply voltage.
6. 24-v alarm signal shown. For dry alarm contact, cut JW4 jumper and dry contact will be available between AL1 and AL2.
7. Transformer secondary ground via Deluxe D board standoffs and screws to control box. (Ground available from top two standoffs as shown.)
8. Aquastat is supplied with unit and must be wired in series with the hot leg to the pump. Aquastat is rated for voltage up to 277 v.
9. Blower motor is factory wired for high and low speeds. No other combination is available.

DELUXE D CONTROLLER FAULT CODES

OPERATION	STATUS LED (GREEN)	TEST LED (YELLOW)	FAULT LED (RED)	ALARM RELAY
Normal Mode	ON	OFF	Note 2	Open
Deluxe D is Non-Functional	OFF	OFF	OFF	Open
Test Mode	—	ON	Note 2	Cycle (Note 3)
Night Setback	Flashing Code 2	—	Note 2	—
Emergency Shut Down	Flashing Code 3	—	Note 2	—
Invalid Thermostat Inputs	Flashing Code 4	—	Note 2	—
No Fault in Memory	ON	OFF	Flashing Code 1	Open
HP Fault/(Lockout) Note 1	Slow Flash/(Fast Flash)	OFF	Flashing Code 2	Open/(Closed)
LP Fault/(Lockout) Note 1	Slow Flash/(Fast Flash)	OFF	Flashing Code 3	Open/(Closed)
FP1 Fault/(Lockout) Note 1	Slow Flash/(Fast Flash)	OFF	Flashing Code 4	Open/(Closed)
FP2 Fault/(Lockout) Note 1	Slow Flash/(Fast Flash)	OFF	Flashing Code 5	Open/(Closed)
CC Fault/(Lockout) Note 1	Slow Flash/(Fast Flash)	OFF	Flashing Code 6	Open/(Closed)
Over-Under Voltage	Slow Flash	OFF	Flashing Code 7	Open (Note 4)
Normal Mode with UPS	ON	OFF	Flashing Code 8	Cycle (Note 5)
Swapped FP1/FP2 Lockout	Fast Flash	OFF	Flashing Code 9	Closed

NOTES:

1. Status LED (GREEN) Slow Flash - Controller In - Fault Retry Mode. Fast Flash - Controller in Lockout Mode. Slow Flash = 1 Flash per every 2 seconds. Fast Flash = 2 Flashes per every 1 second.
2. Fault LED (RED) flashes a code representing last fault in memory. If no fault in memory code 1 is flashed.
3. Cycles appropriate code, by cycling alarm relay in the same sequence as fault LED.
4. Alarm relay closes after 15 minutes.
5. Alarm relay cycles. Closed for 5 seconds and open for 25 seconds.

Typical control wiring schematics (cont)



UNITS WITH DELUXE D CONTROLLER, 208/230 V, THREE-PHASE UNITS

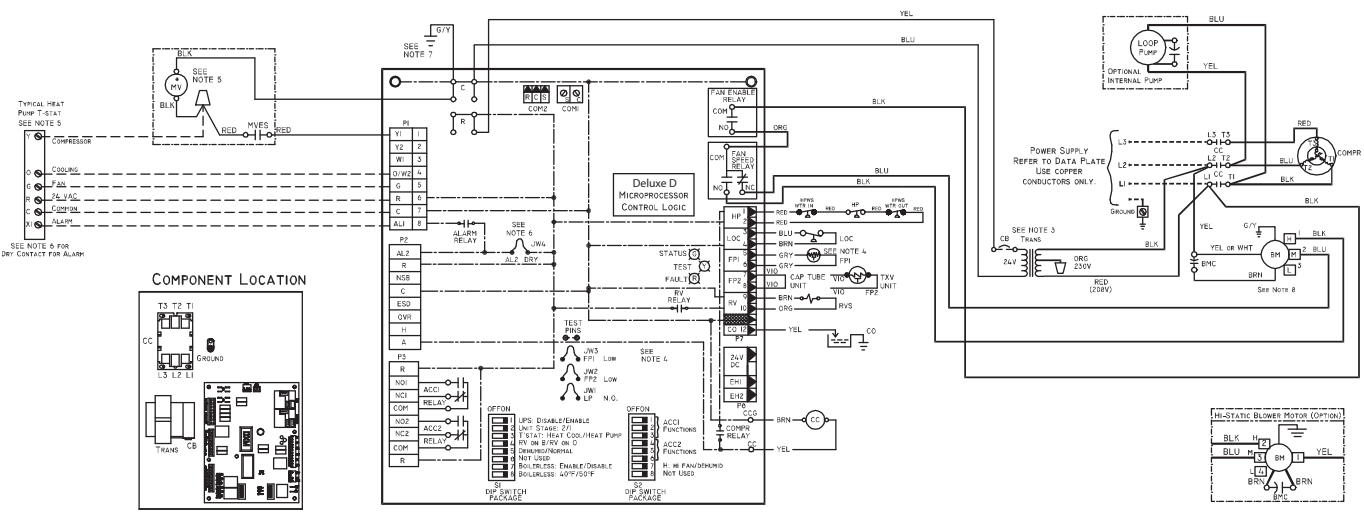

LEGEND

- AL — Alarm Relay Contacts
- BM — Blower Motor
- BMC — Blower Motor Capacitor
- CB — Circuit Breaker
- CC — Compressor Contactor
- CO — Condensate Overflow Sensor
- COMP — Compressor
- FP1 — Water Coil Freeze Protection Sensor
- FP2 — Air Coil Freeze Protection Sensor
- HP — High-Pressure Switch
- HPWS — High Pressure Water Switch
- JW — Jumper Wire
- LOC — Loss of Charge Pressure Switch
- MV — Motorized Valve
- MVES — Motorized Valve End Switch
- NEC — National Electric Code
- P1 — Field Wiring Terminal Block
- RVS — Reversing Valve Solenoid
- TRANS — Transformer
- TXV — Thermostatic Expansion Valve

- Factory Low Voltage Wiring
- Factory Line Voltage Wiring
- Field Low Voltage Wiring
- Field Line Voltage Wiring
- Printed Circuit Trace
- Optional Wiring
- Relay/Contactor Coil
- Thermistor
- Condensate Pan
- Circuit Breaker
- Ground

- Solenoid Coil
- Relay Contacts - N.C.
- Relay Contacts - N.O.
- Capacitor
- Temperature Switch
- Low Pressure Switch
- High Pressure Switch
- Wire Nut
- Splice Cap
- LED

*Optional.

NOTES:

- Compressor and blower motor thermally protected internally.
- All wiring to the unit must comply with NEC and local codes.
- 208/230 v transformer will be connected for 208 v operation. For 230 v operation, disconnect RED lead at L1 and attach ORANGE lead to L1. Insulate open end of RED lead. Transformer is energy limiting or may have circuit breaker.
- FP1 thermistor provides freeze protection for water. When using antifreeze solutions, cut JW3 jumper.
- Check installation wiring information for specific thermostat hookup. Refer to thermostat installation instructions for wiring to the unit. Thermostat wiring must be "Class 1" and voltage rating equal to or greater than unit supply voltage.
- 24-v alarm signal shown. For dry alarm contact, cut JW4 jumper and dry contact will be available between AL1 and AL2.
- Transformer secondary ground via Deluxe D board standoffs and screws to control box. (Ground available from top two standoffs as shown.)
- Aquastat is supplied with unit and must be wired in series with the hot leg to the pump. Aquastat is rated for voltage up to 277 v.
- Blower motor is factory wired for high and low speeds. No other combination is available.

DELUXE D CONTROLLER FAULT CODES

OPERATION	STATUS LED (GREEN)	TEST LED (YELLOW)	FAULT LED (RED)	ALARM RELAY
Normal Mode	ON	OFF	Note 2	Open
Deluxe D is Non-Functional	OFF	OFF	OFF	Open
Test Mode	—	ON	Note 2	Cycle (Note 3)
Night Setback	Flashing Code 2	—	Note 2	—
Emergency Shut Down	Flashing Code 3	—	Note 2	—
Invalid Thermostat Inputs	Flashing Code 4	—	Note 2	—
No Fault in Memory	ON	OFF	Flashing Code 1	Open
HP Fault/(Lockout) Note 1	Slow Flash/(Fast Flash)	OFF	Flashing Code 2	Open/(Closed)
LP Fault/(Lockout) Note 1	Slow Flash/(Fast Flash)	OFF	Flashing Code 3	Open/(Closed)
FP1 Fault/(Lockout) Note 1	Slow Flash/(Fast Flash)	OFF	Flashing Code 4	Open/(Closed)
FP2 Fault/(Lockout) Note 1	Slow Flash/(Fast Flash)	OFF	Flashing Code 5	Open/(Closed)
CC Fault/(Lockout) Note 1	Slow Flash/(Fast Flash)	OFF	Flashing Code 6	Open/(Closed)
Over-Under Voltage	Slow Flash	OFF	Flashing Code 7	Open (Note 4)
Normal Mode with UPS	ON	OFF	Flashing Code 8	Cycle (Note 5)
Swapped FP1/FP2 Lockout	Fast Flash	OFF	Flashing Code 9	Closed

NOTES:

- Status LED (GREEN) Slow Flash - Controller In - Fault Retry Mode. Fast Flash - Controller in Lockout Mode. Slow Flash = 1 Flash per every 2 seconds. Fast Flash = 2 Flashes per every 1 second.
- Fault LED (RED) flashes a code representing last fault in memory. If no fault in memory code 1 is flashed.
- Cycles appropriate code, by cycling alarm relay in the same sequence as fault LED.
- Alarm relay closes after 15 minutes.
- Alarm relay cycles. Closed for 5 seconds and open for 25 seconds.

UNITS WITH DELUXE D CONTROLLER, 460 AND 575 V, THREE-PHASE UNITS

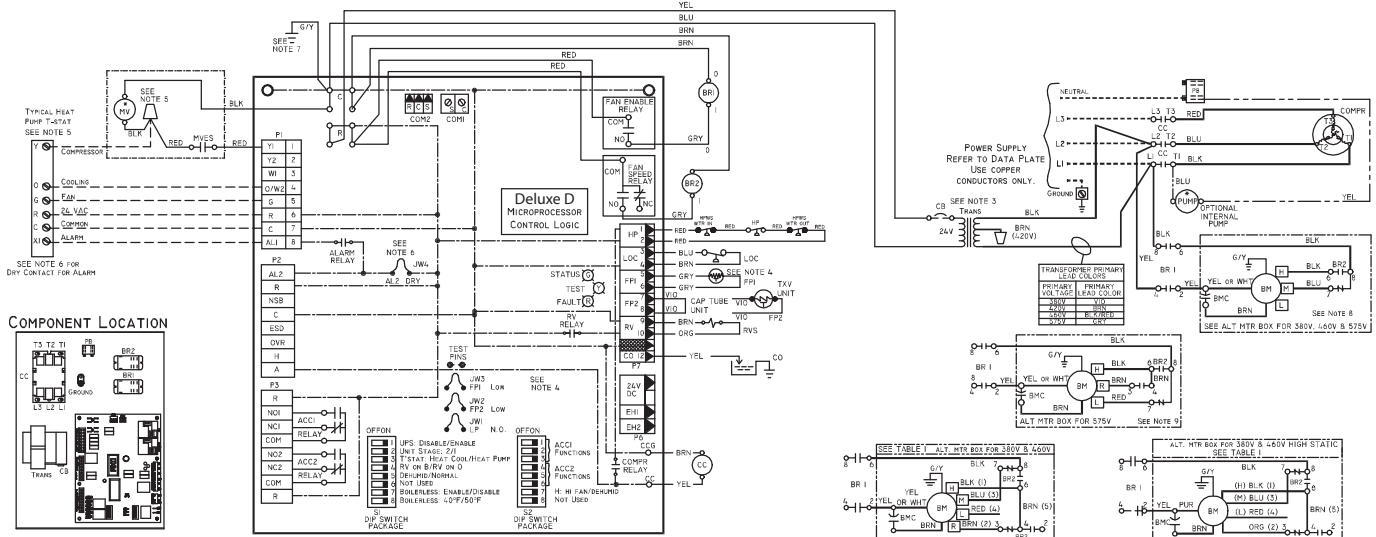

- COMPONENT LOCATION**
-
- AL** — Alarm Relay Contacts
 - BM** — Blower Motor
 - BMC** — Blower Motor Capacitor
 - BR** — Blower Relay
 - CB** — Circuit Breaker
 - CC** — Compressor Contactor
 - CO** — Condensate Overflow Sensor
 - COMP** — Compressor
 - FP1** — Water Coil Freeze Protection Sensor
 - FP2** — Air Coil Freeze Protection Sensor
 - HP** — High-Pressure Switch
 - HPWS** — High Pressure Water Switch
 - JW** — Jumper Wire
 - LOC** — Loss of Charge Pressure Switch
 - MV** — Motorized Valve
 - MVES** — Motorized Valve End Switch
 - NEC** — National Electric Code
 - P1** — Field Wiring Terminal Block
 - PB** — Power Block
 - RVS** — Reversing Valve Solenoid
 - TRANS** — Transformer
 - TXV** — Thermostatic Expansion Valve

- LEGEND**
- Factory Low Voltage Wiring
 - Factory Line Voltage Wiring
 - Field Low Voltage Wiring
 - Field Line Voltage Wiring
 - Printed Circuit Trace
 - Optional Wiring
 - Relay/Contactor Coil
 - Thermistor
 - Condensate Pan
 - Circuit Breaker
 - Ground
 - Solenoid Coil
 - Relay Contacts - N.C.
 - Relay Contacts - N.O.
 - Capacitor
 - Temperature Switch
 - Low Pressure Switch
 - High Pressure Switch
 - Wire Nut
 - Splice Cap
 - LED

- NOTES:**
1. Compressor and blower motor thermally protected internally.
 2. All wiring to the unit must comply with NEC and local codes.
 3. Transformer is wired to 460 v (BLK/RED) lead for 460/60/3 units. 575 v (GRY) lead for 575/60/3. Transformer is energy limiting or may have circuit breaker.
 4. FP1 thermistor provides freeze protection for water. When using antifreeze solutions, cut JW3 jumper.
 5. Check installation wiring information for specific thermostat hookup. Refer to thermostat installation instructions for wiring to the unit. Thermostat wiring must be "Class 1" and voltage rating equal to or greater than unit supply voltage.
 6. 24-v alarm signal shown. For dry alarm contact, cut JW4 jumper and dry contact will be available between AL1 and AL2.
 7. Transformer secondary ground via Deluxe D board standoffs and screws to control box. (Ground available from top two standoffs as shown.)
 8. Blower motors factory wired for medium and high speeds. For any other combination of speeds, at the motor, attach the black wire to the higher of the two desired speed taps. Attach the blue wire to the lower of the desired two speed taps.
 9. Blower motor is factory wired for high and low speeds. No other combination is available.

DELUXE D CONTROLLER FAULT CODES

OPERATION	STATUS LED (GREEN)	TEST LED (YELLOW)	FAULT LED (RED)	ALARM RELAY
Normal Mode	ON	OFF	Note 2	Open
Deluxe D is Non-Functional	OFF	OFF	OFF	Open
Test Mode	—	ON	Note 2	Cycle (Note 3)
Night Setback	Flashing Code 2	—	Note 2	—
Emergency Shut Down	Flashing Code 3	—	Note 2	—
Invalid Thermostat Inputs	Flashing Code 4	—	Note 2	—
No Fault in Memory	ON	OFF	Flashing Code 1	Open
HP Fault/(Lockout) Note 1	Slow Flash/(Fast Flash)	OFF	Flashing Code 2	Open/(Closed)
LP Fault/(Lockout) Note 1	Slow Flash/(Fast Flash)	OFF	Flashing Code 3	Open/(Closed)
FP1 Fault/(Lockout) Note 1	Slow Flash/(Fast Flash)	OFF	Flashing Code 4	Open/(Closed)
FP2 Fault/(Lockout) Note 1	Slow Flash/(Fast Flash)	OFF	Flashing Code 5	Open/(Closed)
CC Fault/(Lockout) Note 1	Slow Flash/(Fast Flash)	OFF	Flashing Code 6	Open/(Closed)
Over-Under Voltage	Slow Flash	OFF	Flashing Code 7	Open (Note 4)
Normal Mode with UPS	ON	OFF	Flashing Code 8	Cycle (Note 5)
Swapped FP1/FP2 Lockout	Fast Flash	OFF	Flashing Code 9	Closed

- NOTES:**
1. Status LED (GREEN) Slow Flash - Controller In - Fault Retry Mode. Fast Flash - Controller in Lockout Mode. Slow Flash = 1 Flash per every 2 seconds. Fast Flash = 2 Flashes per every 1 second.
 2. Fault LED (RED) flashes a code representing last fault in memory. If no fault in memory code 1 is flashed.
 3. Cycles appropriate code, by cycling alarm relay in the same sequence as fault LED.
 4. Alarm relay closes after 15 minutes.
 5. Alarm relay cycles. Closed for 5 seconds and open for 25 seconds.

Typical control wiring schematics (cont)



UNITS WITH COMPLETE C AND LON CONTROLLER

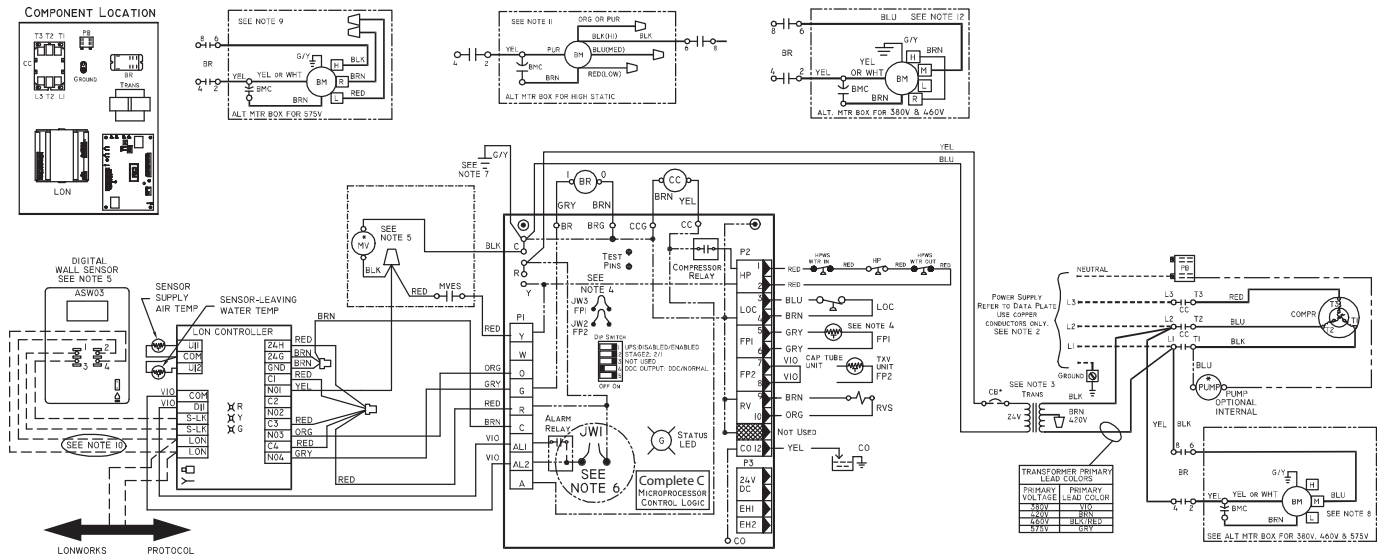

LEGEND

- AL** — Alarm Relay Contacts
- BM** — Blower Motor
- BMC** — Blower Motor Capacitor
- BR** — Blower Relay
- CB** — Circuit Breaker
- CC** — Compressor Contactor
- CO** — Sensor, Condensate Overflow
- FP1** — Sensor, Water Coil Freeze Protection
- FP2** — Sensor, Air Coil Freeze Protection
- HP** — High-Pressure Switch
- HPWS** — High-Pressure Water Switch
- JW1** — Clippable Field Selection Jumper
- LOC** — Loss of Charge Pressure Switch
- LON** — Local Operating Network
- MV** — Motorized Valve
- MVES** — Motorized Valve End Switch
- NEC** — National Electrical Code
- P1** — Field Wiring Terminal Block
- RVS** — Reversing Valve Solenoid

- TRANS** — Transformer
- TXV** — Thermostatic Expansion Valve
- Field Line Voltage Wiring
- - - Field Low Voltage Wiring
- Printed Circuit Trace
- Optional Wiring
- Relay/Contactor Coil
- Condensate Pan
- Solenoid Coil
- Temperature Switch
- Thermistor
- ⊥ Ground

- Wire Nut
- /○ Relay Contacts - N.C.
- /○ Relay Contacts - N.O.
- /○ Low Pressure Switch
- /○ High Pressure Switch
- Splice Cap
- /○ Circuit Breaker

*Optional Wiring.

NOTES:

1. Compressor and blower motor thermally protected internally.
2. All wiring to the unit must comply with NEC and local codes.
3. Transformer is wired to 460 v (BLK/RED) lead for 460/3/60 units. Transformer is energy limiting or may have circuit breaker.
4. FP1 thermistor provides freeze protection for water. When using antifreeze solutions, cut JW3 jumper.
5. Typical thermostat wiring shown. Refer to thermostat installation instructions for wiring to the unit. Thermostat wiring must be Class 1 and voltage rating equal to or greater than unit supply voltage.
6. Factory cut JW1 jumper. Dry contact will be available between AL1 and AL2.
7. Transformer secondary ground via Complete C board stand-offs and screws to control box. (Ground available from top two standoffs as shown.)

8. Fan motors factory wired for medium speed. For high and low speed remove BLU wire from fan motor speed tap 'M' and connect to 'H' for high or 'L' for low.
9. For low speed remove black wire from BR6 and replace with red. Connect black and brown wire together.
10. Optional LON wires. Only connect if LON connection is desired at the wall sensor.
11. For blower motors with leads, for medium or low speed, disconnect black wire from BR6. Connect black and orange/purple wire together. Connect red for low or blue for medium to BR6.
12. Fan motors factory wired for medium speed. For high and low speed remove BLU wire from fan motor speed tap 'M' and connect to 'H' for high or 'L' for low. Remove brown jumper wire from tap. Insulate open end of brown jumper.

UNITS WITH DELUXE D AND LON CONTROLLER

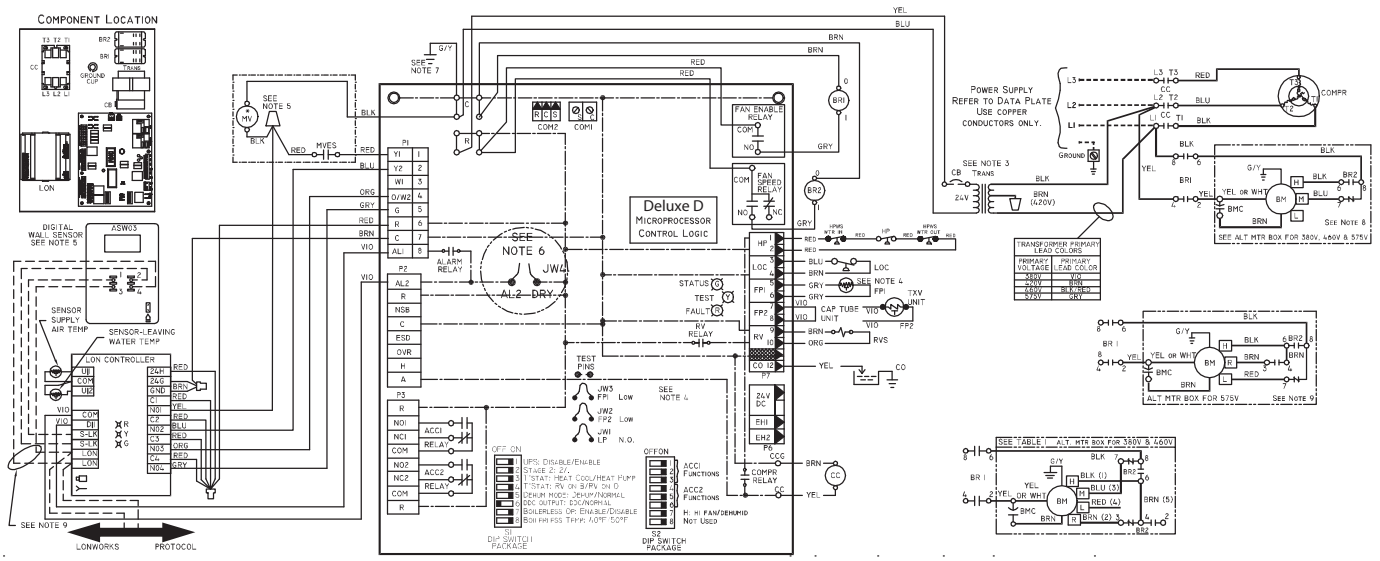

LEGEND

- | | | |
|--|--|---|
| <p>AL — Alarm Relay Contacts</p> <p>BM — Blower Motor</p> <p>BMC — Blower Motor Capacitor</p> <p>BR — Blower Relay</p> <p>CB — Circuit Breaker</p> <p>CC — Compressor Contactor</p> <p>CO — Sensor, Condensate Overflow</p> <p>FP1 — Sensor, Water Coil Freeze Protection</p> <p>FP2 — Sensor, Air Coil Freeze Protection</p> <p>HP — High-Pressure Switch</p> <p>HPWS — High-Pressure Water Switch</p> <p>JW1 — Clippable Field Selection Jumper</p> <p>LOC — Loss of Charge Pressure Switch</p> <p>LON — Local Operating Network</p> <p>MV — Motorized Valve</p> <p>MVES — Motorized Valve End Switch</p> <p>NEC — National Electrical Code</p> <p>P1 — Field Wiring Terminal Block</p> <p>RVS — Reversing Valve Solenoid</p> | <p>TRANS — Transformer</p> <p>TXV — Thermostatic Expansion Valve</p> <p>--- Field Line Voltage Wiring</p> <p>--- Field Low Voltage Wiring</p> <p>--- Printed Circuit Trace</p> <p>--- Optional Wiring</p> <p>○ Relay/Contactor Coil</p> <p>Condensate Pan</p> <p>○ Solenoid Coil</p> <p>○ Temperature Switch</p> <p>○ Thermistor</p> <p>⊥ Ground</p> | <p>⊔ Wire Nut</p> <p>⊔ Relay Contacts - N.C.</p> <p>⊔ Relay Contacts - N.O.</p> <p>⊔ Low Pressure Switch</p> <p>⊔ High Pressure Switch</p> <p>⊔ Splice Cap</p> <p>⊔ Circuit Breaker</p> |
|--|--|---|

*Optional Wiring.

NOTES:

1. Compressor and blower motor thermally protected internally.
2. All wiring to the unit must comply with NEC and local codes.
3. Transformer is wired to 460 v (BLK/RED) lead for 460/3/60 units. Transformer is energy limiting or may have circuit breaker.
4. FP1 thermistor provides freeze protection for water. When using antifreeze solutions, cut JW3 jumper.
5. Typical thermostat wiring shown. Refer to thermostat installation instructions for wiring to the unit. Thermostat wiring must be Class 1 and voltage rating equal to or greater than unit supply voltage.
6. Factory cut JW4 jumper. Dry contact will be available between AL1 and AL2.
7. Transformer secondary ground via Deluxe D board standoffs and screws to control box. (Ground available from top two standoffs as shown.)
8. Blower motor is factory wired for medium and high speeds. For any other combination of speeds, at the motor attach the BLK wire to the higher of the two desired speed taps and the BLU wire to the lower of the two desired speed taps.
9. Blower motor is factory wired for high and low speeds. No other combination is available.
10. Optional LON wires. Only connect if LON connection is desired at the wall sensor.

Typical control wiring schematics (cont)



PREMIERLINK™ CONTROLLER APPLICATIONS WITH COMPLETE C CONTROL

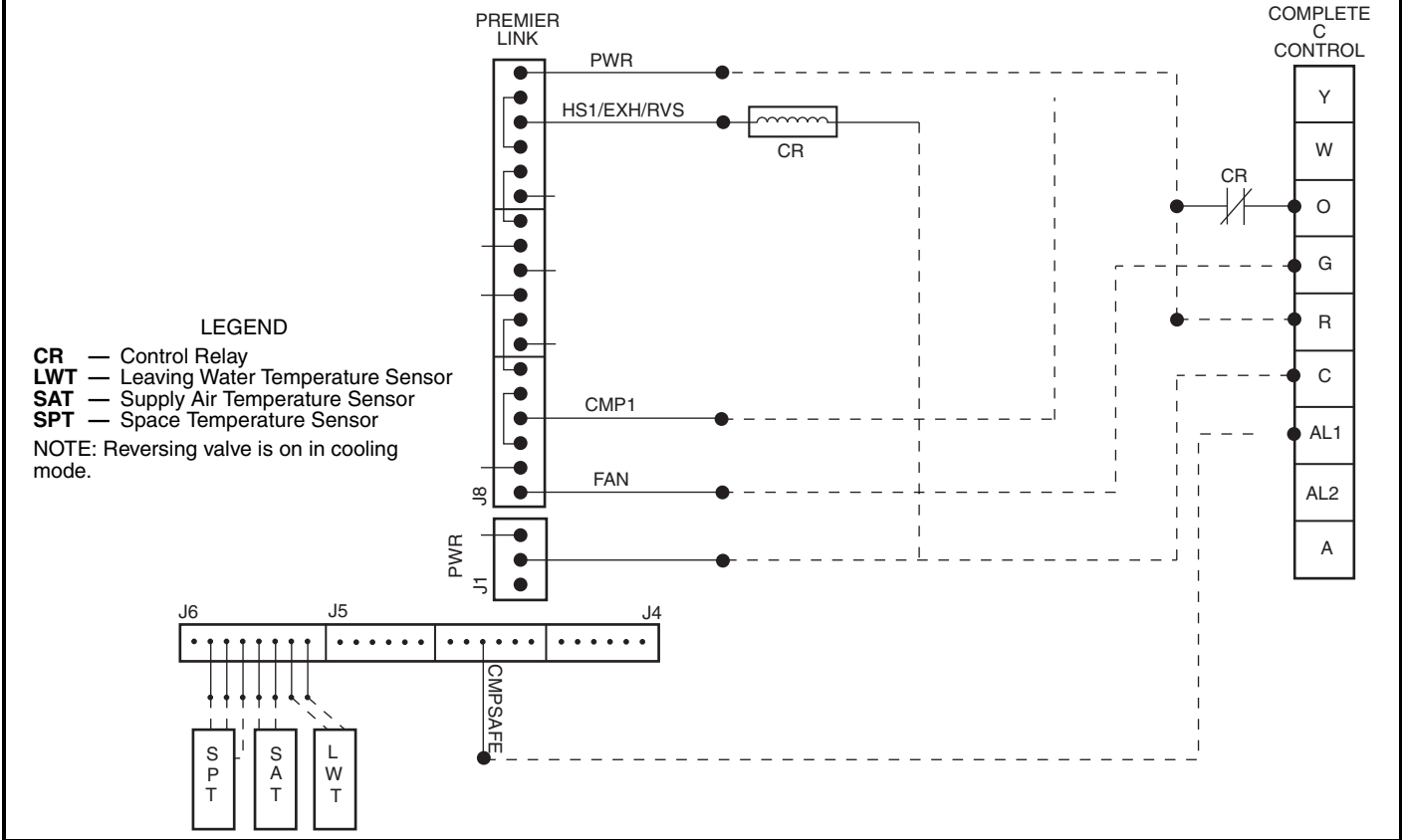

PREMIERLINK CONTROLLER APPLICATIONS WITH DELUXE D CONTROL

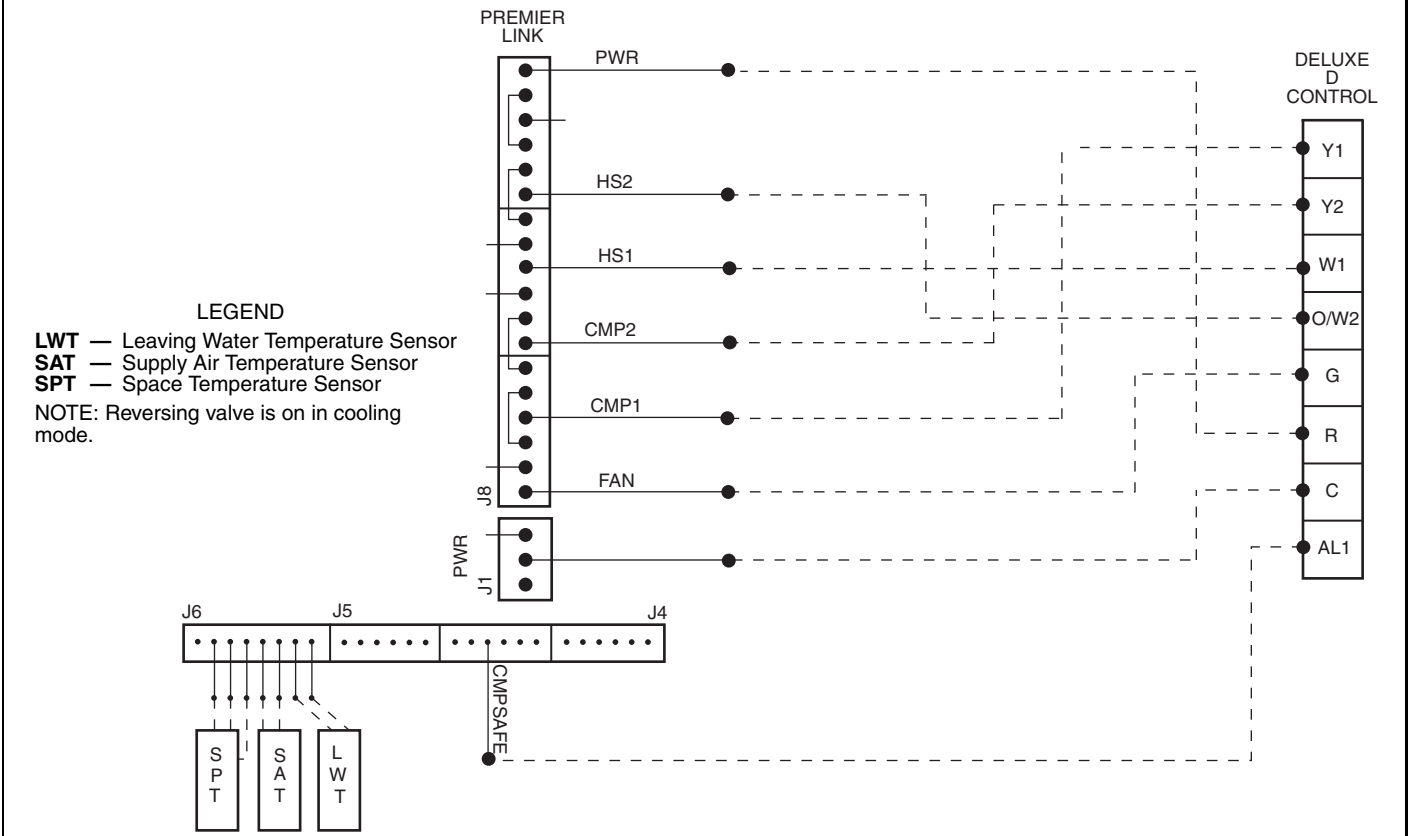

UNITS WITH COMPLETE C AND WSHSP OPEN MULTIPLE PROTOCOL CONTROLS

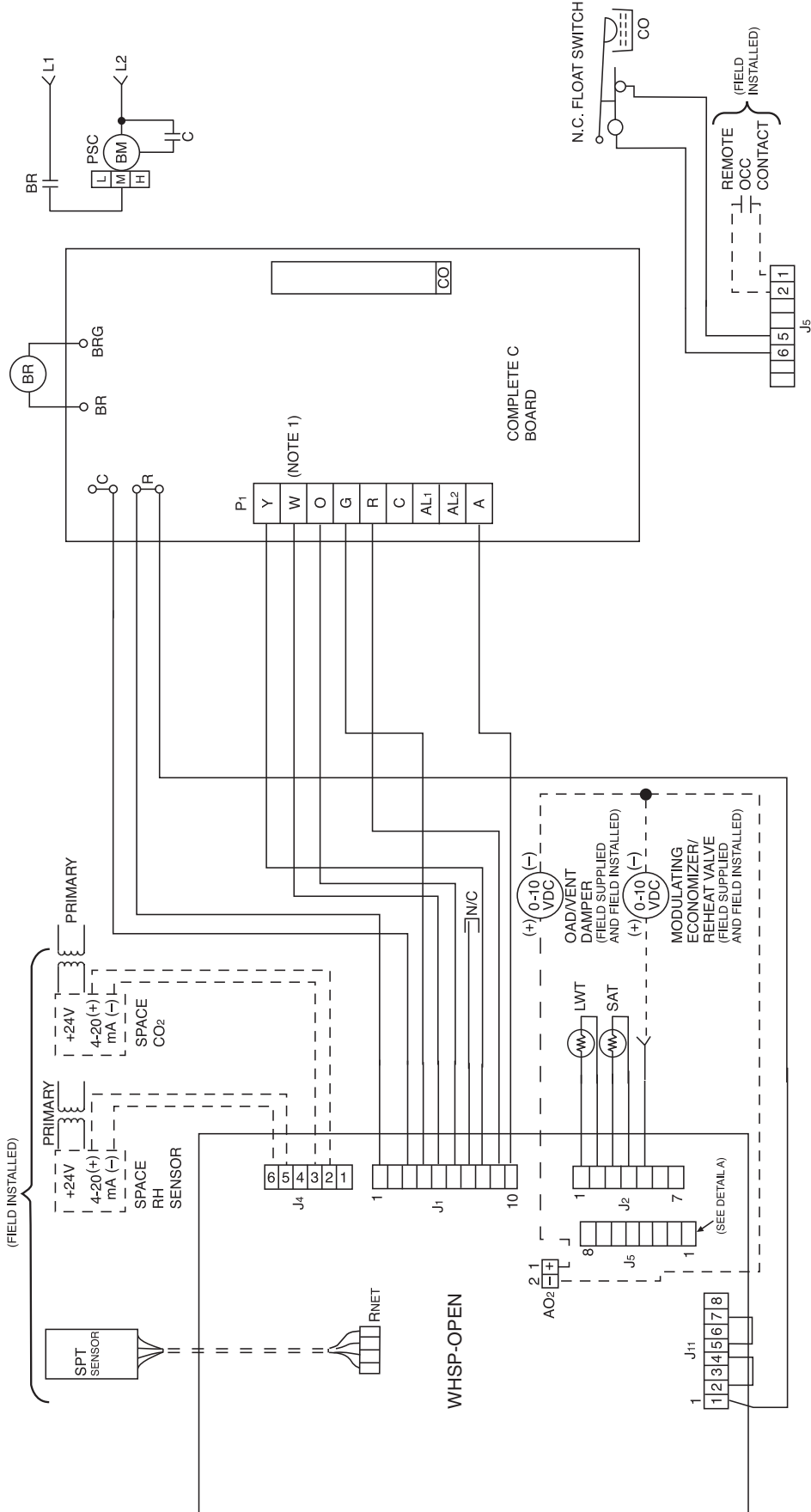

'DETAIL A'

(NOTE 1) - FOR FIELD INSTALLED 2-POS HOT WATER REHEAT COILS, DISCONNECT WIRE FROM TERMINAL W AND CONNECT TO FIELD SUPPLIED HOT WATER VALVE

LEGEND

- BM** — Blower Motor
- BR** — Blower Relay
- CO** — Condensate Overflow
- LWT** — Leaving Water Temperature
- N.C.** — Normally Closed
- OAD** — Outside Air Damper
- OCC** — Occupancy Input Contact
- RH** — Relative Humidity
- SAT** — Supply Air Temperature
- SPT** — Space Temperature

Typical control wiring schematics (cont)



UNITS WITH DELUXE D AND WSHP OPEN MULTIPLE PROTOCOL CONTROLS

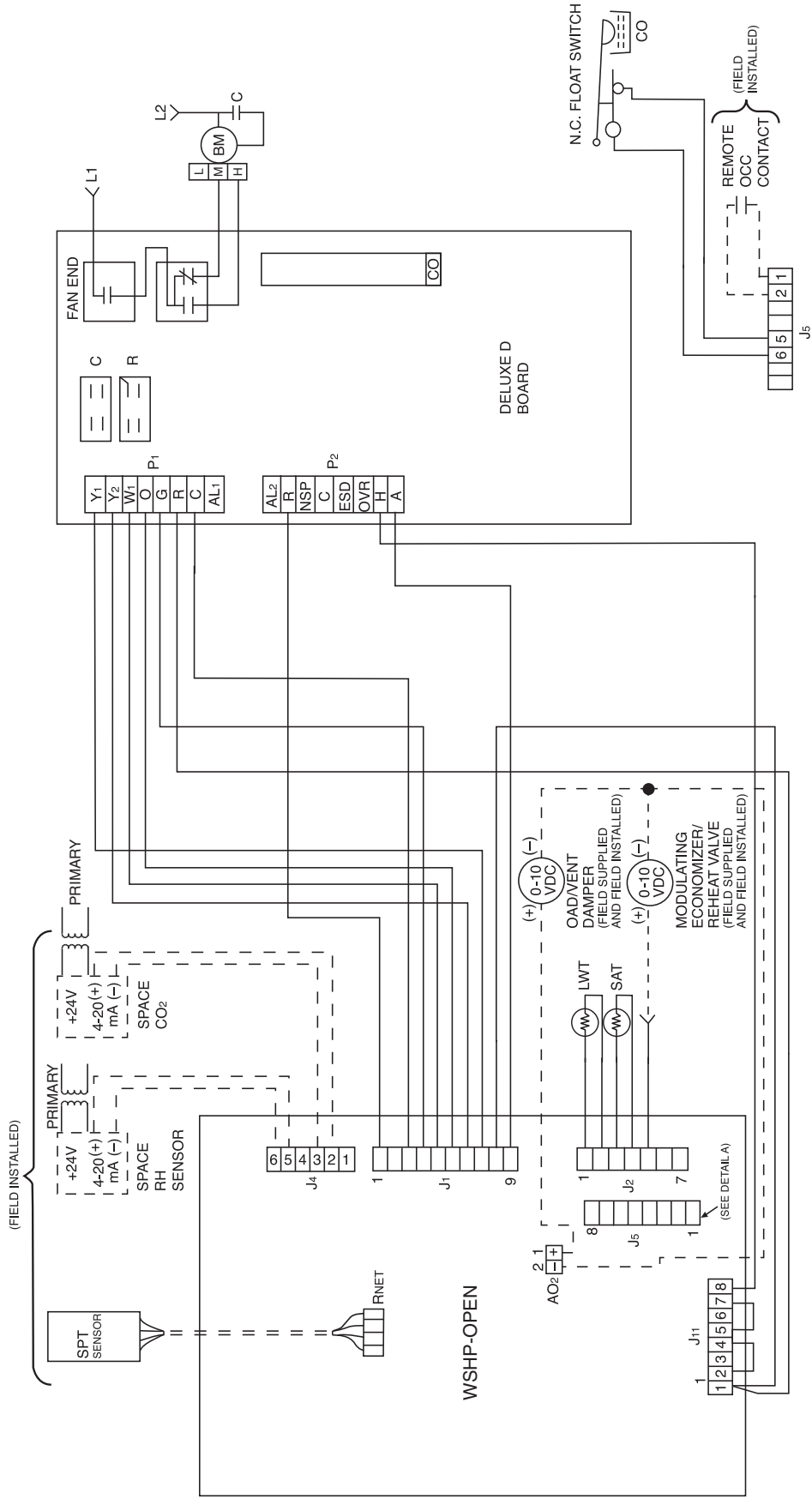

(NOTE 1) - FOR FIELD INSTALLED 2-POS HOT WATER REHEAT COILS, DISCONNECT WIRE FROM TERMINAL W1 AND CONNECT TO FIELD SUPPLIED HOT WATER VALVE

'DETAIL A'

WSHP OPEN MULTIPLE PROTOCOL CONTROLLER

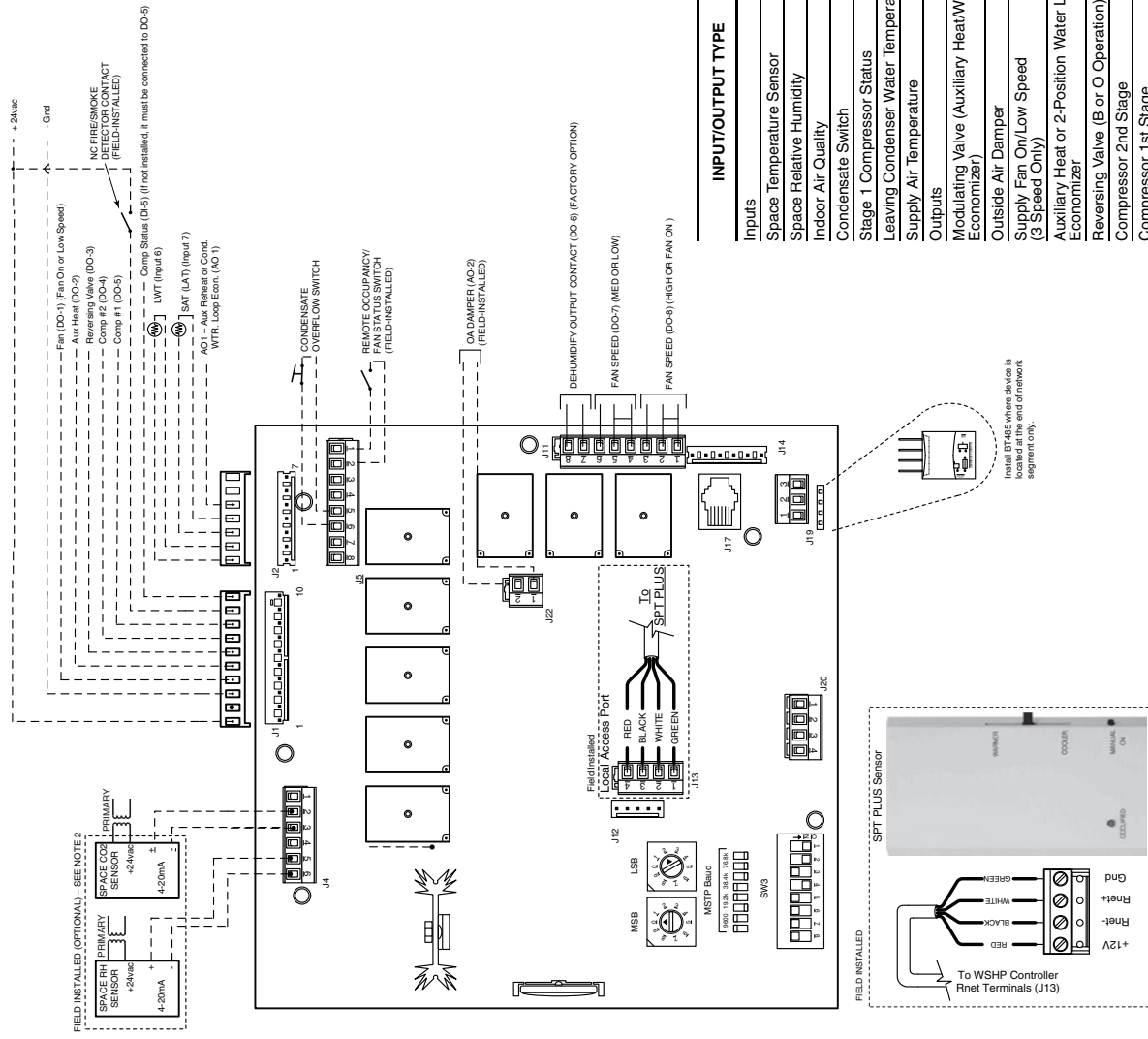

LEGEND

AI	Analog Input
AO	Analog Output
BI	Binary Input
BO	Binary Output
SPT	Space Temperature
---	Factory Wiring
- - -	Field Wiring

NOTES:

- Mount the water source heat pump controller in the equipment controls enclosure with at least two no. 6 x 1 in. self-tapping screws. Allow adequate clearance for wiring.
- Verify sensor power and wiring requirements prior to making any terminations. Sensors requiring a separate isolated 24 vac power source will not utilize WSHP terminals J4-1, or 4.

WSHP Open Inputs and Outputs Table

INPUT/OUTPUT TYPE	PART NUMBERS	TYPE OF I/O	CONNECTION PIN NUMBERS	CHANNEL DESIGNATION
Inputs				
Space Temperature Sensor	SPS, SPPL, SPP	Communicating	J13, 1 - 4	Local Access Port
Space Relative Humidity	33ZCSENSRH-01	AI (4 - 20mA)	J4, 5 and 6	Analog Input 1
Indoor Air Quality	33ZCSENSCO2	AI (4 - 20mA)	J4, 2 and 3	Analog Input 2
Condensate Switch	N/A	BI (Dry Contacts)	J1, 2	Binary Input 3
Stage 1 Compressor Status	N/A	BI (Dry Contacts)	J1, 10	Binary Input 5
Leaving Condenser Water Temperature	10K Type II	AI (10K Thermistor)	J2, 1 and 2	Analog Input 6
Supply Air Temperature	33ZCSENSAT	AI (10K Thermistor)	J2, 3 and 4	Analog Input 7
Outputs				
Modulating Valve (Auxiliary Heat/Water Economizer)	N/A	AO (0-10Vdc/2 - 10Vdc)	J2 4 and 5*	Analog Output 1
Outside Air Damper	N/A	AO (0-10Vdc/2 - 10Vdc)	J22 1 and 2*	Analog Output 2
Supply Fan On/Off (3 Speed Only)	N/A	BO Relay (24VAC, 1A)	J1, 4*	Binary Output 1 (G)
Auxiliary Heat or 2-Position Water Loop Economizer	N/A	BO Relay (24VAC, 1A)	J1, 5*	Binary Output 2
Reversing Valve (B or O Operation)	N/A	BO Relay (24VAC, 1A)	J1, 6*	Binary Output 3 (RV)
Compressor 2nd Stage	N/A	BO Relay (24VAC, 1A)	J1, 7	Binary Output 4 (Y2)
Compressor 1st Stage	N/A	BO Relay (24VAC, 1A)	J1, 8	Binary Output 5 (Y1)
Dehumidification Relay	N/A	BO Relay (24VAC, 1A)	J11, 7 and 8 (NO)	Binary Output 6
Fan Speed Medium/Low (3 Speed Only)	N/A	BO Relay (24VAC, 1A)	J11, 5 and 6 (NO)*	Binary Output 7
Fan Speed High/Low (3 Speed Only)	N/A	BO Relay (24VAC, 1A)	J11, 2 and 3 (NO)*	Binary Output 8

*These inputs are configurable.

Application data



Aquazone™ water source heat pump products are available in a flexible, efficient array of models, which can be used in all types of water loop, ground water, and ground loop type systems. Utilize Aquazone products to provide optimal energy efficient solutions and adapt to the most challenging design requirements.

AQUAZONE PRODUCT GUIDE

50 SERIES	TYPE SIZE (tons)	APPLICATION
50HQP,VQP	Large Capacity 6-10 (HQP) 6 1/2-25 (VQP)	Environmentally sound unit with Puron® refrigerant (R-410A) designed to handle large zoned areas for all geothermal and boiler/tower applications.
50PC	Compact 1 1/4-5	Compact WSHP with Puron refrigerant (R-410A) for boiler/tower, ground water, or ground loop systems.
50PS	Premium Efficiency 1/2-6	Premium, ultra efficient unit with Puron refrigerant (R-410A) for new boiler/tower, ground water, or ground loop systems
50PEC	High Efficiency Console 3/4-1 1/2	Efficient console unit with Puron refrigerant (R-410A) and attractive design for finished interior, under-window installations.
50PT	Premium Efficiency 2-6	Premium, ultra efficient 2-stage unit with Puron refrigerant (R-410A) for new boiler/tower, ground water, or ground loop systems
50PSW	Water-to-Water 3-28	Efficient unit with Puron refrigerant (R-410A) serves as an alternative to pre-heat or cool air. Unit can be used as a stand-alone or supplemental boiler/chiller in most hydronic heating applications. Also conditions process fluids, lubricants, and refrigerants.
50RTP	Rooftop 3-20	Economical solution for indoor air quality (IAQ) problems and tempering ventilation air.
50VS	Premium Efficiency Vertical Stack Heat Pump 3/4 to 3 Tons	Ultra efficient unit with environmentally sound Puron refrigerant (R-410A) for boiler/tower and geothermal applications (condominiums, hotels, etc.). Stacked design allows for common piping and simplistic design.

Water loop system

Water loop (or boiler/tower) system applications typically include a number of units plumbed to a common piping system. For optimal performance, this system should be designed between 2.25 and 3 gpm per ton of cooling capacity. The system is comprised of highly efficient packaged reverse cycle heat pump units interconnected by a water loop. The water circuit serves as both a sink and source for heat absorption and rejection and is designed for entering water temperatures between 60 F and 90 F. Within this temperature range units can heat or cool as required from the same water source. Transferring heat from warm to cold spaces in the building, whenever they coexist, conserves energy rather than creating new heat.

Refer to the **Carrier Water Source Heat Pump System Design Guide** for assistance with the design of water loop systems. The guide includes a practical approach for the latest and most current design recommendations including:

- product application, including horizontal, vertical, console, rooftop and water-to-water applications
- ventilation methods and system design, including energy recovery
- acoustical considerations for different product types
- addressing indoor air quality (IAQ) issues such as condensate removal and humidity control

- air distribution design including diffuser selection/layout and ductwork design
- hydronic system design including pipe sizing/layout and boiler/tower sizing
- control configurations such as standalone, DDC, DCV, and VVT® controls
- Water Source Heat Pump Efficiency/Operational Cost Comparison chart
- system variations such as a system without a boiler, variable pumping, and variable air volume (VAV) for interior use

Ground water systems

To utilize Aquazone units in ground water applications, extended range should be specified. This will provide factory-installed insulation on the coaxial coil to prevent condensate from dripping when entering water temperatures are below 60 F. In addition, the copper coaxial coil installed on the Aquazone units may not be suitable for all water conditions. Refer to the Water Conditioning section for proper coaxial coil material selection.

Surface water system — This system is typically located near a lake or pond. In this application, the loop can be submerged in a series of coils beneath the water surface. The number of coils required depends on system load and design. This application requires minimum piping and excavation.

Open loop system — This system is used where ground water is plentiful. In this application, ground water is pumped through supply piping from the well to the building. The water is then pumped back into the ground through a discharge well as it leaves the building. An additional heat exchanger is usually installed between the building water piping system and the ground water piping system. This design limits the amount of piping and excavation required.

Aquazone units are provided with a standard thermostatic expansion valve (TXV) and are rated to extremely low temperatures to self-adjust the refrigeration circuit, therefore water regulating valves are not required on open loop systems. To conserve water on this type of system, a slow opening/closing solenoid valve is recommended.

Ground loop systems

There are many commonly specified designs for ground loop applications. Typical designs include vertical loops and horizontal loops. In some applications, water is piped from the ground or lake directly to the water source heat pump. Piping is limited to the amount of pipe required to get the water from the source to the unit.

NOTE: When utilizing Aquazone water source heat pumps in ground loop systems, refer to design considerations in the ground water system section.

Horizontal ground loop — This system is used when adequate space is available and trenching can be easily accomplished. A series of parallel pipes are laid out in trenches 3 to 6 ft below the ground surface, and then back-filled. Often, multiple pipes are used to maximize the heat transfer capability of each trench. The amount of pipe and the size of the ground loop field are based on ground conditions, heating, and cooling requirements of the application and system design.

Vertical ground loop — This system is used in vertical borehole applications. This design is well suited for retrofit applications when space is limited or where landscaping is already complete and minimum disruption of the site is desired. The vertical ground loop system contains a single loop of pipe inserted into a hole. The hole is back-filled and grouted after the pipe is inserted. The completed loop is concealed below ground. The number of loops required depends on ground conditions, heating and cooling requirements, and the depth of each hole.

Hybrid systems — In some applications, it may be beneficial to incorporate a cooling tower into the ground loop system to reduce the overall cost. A hybrid system discards excess heat into the air and increases the cooling performance of the ground loop.

Condensate drainage

Venting — Condensate lines should be properly vented to prevent fan pressure from causing water to hang up in the piping. Condensate lines should be pitched to assure full drainage of condensate under all load conditions. Chemical treatment should be provided to remove algae in the condensate pans and drains in geographical areas that are conducive to algae growth.

Trapping — Condensate trapping is an essential necessity on every water source heat pump unit. A trap is provided to prevent the backflow of moisture from the condensate pan and into the fan intake or downstream into the mechanical system. The water seal or the length of the trap depends on the positive or negative pressure on the drain pan. As a rule of thumb, the water seal should be sized for 1 in. for every 1 in. of negative pressure on the unit. The water seal is the distance from the bottom of the unit condensate piping connection to the bottom of the condensate drain line run-out piping. Therefore, the trap size should be double the water seal dimension.

Horizontal units — Horizontal units should be sloped toward the drain at a $\frac{1}{4}$ in. per foot pitch. If it is not possible to meet the pitch requirement, a condensate pump should be designed and installed at the unit to pump condensate to a building drain. Horizontal units are not internally trapped; therefore an external trap is necessary. Each unit must be installed with its own individual trap and means to

flush or blow out the condensate drain. The design of a common trap or vent for multiple units is not acceptable. The condensate piping system should not be designed with a pipe size smaller than the drain connection pipe size.

Vertical units — Vertical units utilize a condensate hose inside the cabinet that acts as a trapping loop, therefore an external trap is not necessary. Each unit must be installed with its own vent and means to flush or blow out the condensate drain lines. Do not install a common trap or vent on vertical units.

Water conditioning

In some applications, maintaining proper water quality may require the use of higher corrosion protection for the water-to-refrigerant heat exchanger. Water quality varies from location to location and is unique for each job. Water characteristics such as pH value, alkalinity, hardness, and specific conductance are of importance when considering any WSHP application. Water typically includes impurities and hardness that must be removed. The required treatment will depend on the water quality as well as type of system. Water problems fall into three main categories:

1. Scale formation caused by hard water reduces the heat transfer rate and increases the water pressure drop through the heat exchanger. As water is heated, minerals and salts are precipitated from a solution and deposited on the inside surface of the pipe or tube.
2. Corrosion is caused by absorption of gases from the air coupled with water on exposed metal. Corrosion is also common in salt-water areas.
3. Organic growths such as algae can reduce the heat transfer rate by forming an insulating coating on the inside tube surface. Algae can also promote corrosion by pitting.

NOTE: In most commercial water loop applications, Aquazone™ WSHP units use a copper water-to-refrigerant heat exchanger. Units can also be equipped with a cupronickel heat exchanger for applications where water is outside the standard contaminant limits for a copper heat exchanger.

Application data (cont)



WATER QUALITY GUIDELINES

CONDITION	HX MATERIAL*	CLOSED RECIRCULATING†	OPEN LOOP AND RECIRCULATING WELL**																								
Scaling Potential — Primary Measurement																											
Above the given limits, scaling is likely to occur. Scaling indexes should be calculated using the limits below.																											
pH/Calcium Hardness Method	All	N/A	pH < 7.5 and Ca Hardness, <100 ppm																								
Index Limits for Probable Scaling Situations (Operation outside these limits is not recommended.)																											
Scaling indexes should be calculated at 150 F for direct use and HWG applications, and at 90 F for indirect HX use. A monitoring plan should be implemented.																											
Ryznar Stability Index	All	N/A	6.0 - 7.5 If >7.5 minimize steel pipe use.																								
Langelier Saturation Index	All	N/A	-0.5 to +0.5 If <-0.5 minimize steel pipe use. Based upon 150 F HWG and direct well, 85 F indirect well HX.																								
Iron Fouling																											
Iron Fe ²⁺ (Ferrous) (Bacterial Iron Potential)	All	N/A	<0.2 ppm (Ferrous) If Fe ²⁺ (ferrous) >0.2 ppm with pH 6 - 8, O ₂ <5 ppm check for iron bacteria.																								
Iron Fouling	All	N/A	<0.5 ppm of Oxygen Above this level deposition will occur.																								
Corrosion Prevention††																											
pH	All	6 - 8.5 Monitor/treat as needed.	6 - 8.5 Minimize steel pipe below 7 and no open tanks with pH <8.																								
Hydrogen Sulfide (H ₂ S)	All	N/A	<0.5 ppm At H ₂ S>0.2 ppm, avoid use of copper and cupronickel piping or HXs. Rotten egg smell appears at 0.5 ppm level. Copper alloy (bronze or brass) cast components are okay to <0.5 ppm.																								
Ammonia Ion as Hydroxide, Chloride, Nitrate and Sulfate Compounds	All	N/A	<0.5 ppm																								
Maximum Chloride Levels			Maximum allowable at maximum water temperature.																								
			<table border="1"> <thead> <tr> <th></th> <th>50 F (10 C)</th> <th>75 F (24 C)</th> <th>100 F (38 C)</th> </tr> </thead> <tbody> <tr> <td>Copper</td> <td><20 ppm</td> <td>NR</td> <td>NR</td> </tr> <tr> <td>Cupronickel</td> <td><150 ppm</td> <td>NR</td> <td>NR</td> </tr> <tr> <td>304 SS</td> <td><400 ppm</td> <td><250 ppm</td> <td><150 ppm</td> </tr> <tr> <td>316 SS</td> <td><1000 ppm</td> <td><550 ppm</td> <td><375 ppm</td> </tr> <tr> <td>Titanium</td> <td>>1000 ppm</td> <td>>550 ppm</td> <td>>375 ppm</td> </tr> </tbody> </table>		50 F (10 C)	75 F (24 C)	100 F (38 C)	Copper	<20 ppm	NR	NR	Cupronickel	<150 ppm	NR	NR	304 SS	<400 ppm	<250 ppm	<150 ppm	316 SS	<1000 ppm	<550 ppm	<375 ppm	Titanium	>1000 ppm	>550 ppm	>375 ppm
	50 F (10 C)	75 F (24 C)	100 F (38 C)																								
Copper	<20 ppm	NR	NR																								
Cupronickel	<150 ppm	NR	NR																								
304 SS	<400 ppm	<250 ppm	<150 ppm																								
316 SS	<1000 ppm	<550 ppm	<375 ppm																								
Titanium	>1000 ppm	>550 ppm	>375 ppm																								
Erosion and Clogging																											
Particulate Size and Erosion	All	<10 ppm of particles and a maximum velocity of 6 fps. Filtered for maximum 800 micron size.	<10 ppm (<1 ppm "sandfree" for reinjection) of particles and a maximum velocity of 6 fps. Filtered for maximum 800 micron size. Any particulate that is not removed can potentially clog components.																								
Brackish	All	N/A	Use cupronickel heat exchanger when concentrations of calcium or sodium chloride are greater than 125 ppm are present. (Seawater is approximately 25,000 ppm.)																								

LEGEND

- HWG** — Hot Water Generator
- HX** — Heat Exchanger
- N/A** — Design Limits Not Applicable Considering Recirculating Potable Water
- NR** — Application Not Recommended
- SS** — Stainless Steel

*Heat exchanger materials considered are copper, cupronickel, 304 SS (stainless steel), 316 SS, titanium.

†Closed recirculating system is identified by a closed pressurized piping system.

**Recirculating open wells should observe the open recirculating design considerations.

††If the concentration of these corrosives exceeds the maximum allowable level, then the potential for serious corrosion problems exists.

Sulfides in the water quickly oxidize when exposed to air, requiring that no agitation occur as the sample is taken. Unless tested immediately at the site, the sample will require stabilization with a few drops of one Molar zinc acetate solution, allowing accurate sulfide determination up to 24 hours after sampling. A low pH and high alkalinity can cause system problems, even when both values are within ranges shown. The term pH refers to the acidity, basicity, or neutrality of the water supply. Below 7.0, the water is considered to be acidic. Above 7.0, water is considered to be basic. Neutral water contains a pH of 7.0.

To convert ppm to grains per gallon, divide by 17. Hardness in mg/l is equivalent to ppm.



COMPLETE C AND DELUXE D ELECTRONIC CONTROL FEATURES COMPARISON

FEATURES	COMPLETE C	COMPLETE C WITH LON	DELUXE D	DELUXE D WITH LON	COMPLETE C OR DELUXE D WITH WSHP OPEN CONTROLLER
BASIC FEATURES					
High and Low Refrigerant Pressure Protection	S	S	S	S	S
Water Coil Freeze Protection	S	S	S	S	S
True 24 VA Thermostat Signals	S	S	S	S	S
Thermostat Inputs Compatible with Triacs	S	S	S	S	S
Condensate Overflow Sensor	S	S	S	S	S
Anti-Short-Cycle Time Delay	S	S	S	S	S
Random Start	S	S	S	S	S
Alarm (selectable dry contact or 24 VA)	S	S	S	S	S
Water Valve Relay	S	S	S	S	S
Water Valve Relay with Compressor Delay	N/A	N/A	S	S	S
Emergency Shutdown	N/A	DDC	S	DDC	DDC
Night Setback with Override	N/A	DDC	S	DDC	DDC
Outdoor Air Damper Control	N/A	N/A	S	S	S
ADVANCED FEATURES					
Intelligent Reset	S	S	S	S	S
High and Low Voltage Protection	S	S	S	S	S
Air Coil Freeze Protection	S	S	S	S	S
Freeze Set Point Field Select (water, antifreeze)	S	S	S	S	S
Electric Heat Control Outputs	S	S	S	S	S
Boilerless Electric Heat Control	N/A	N/A	S	S	S
Intelligent Reversing Valve Operation	N/A	DDC	S	S	S
High/Low Fan Speed Outputs	N/A	N/A	S	S	S
Intelligent Fan Speed Control	N/A	N/A	S	S	S
Thermostat Type Select (Y,O or Y,W)	N/A	N/A	S	N/A	N/A
Reversing Valve Signal Select (O or B)	N/A	N/A	S	N/A	N/A
Dehumidistat Input	N/A	N/A	S	S	S
Multiple Units on One Thermostat/Wall Sensor	N/A	DDC	S	DDC	DDC
Condenser Waterside/Airside Linkage	N/A	N/A	N/A	N/A	S
Waterside Economizer	N/A	N/A	N/A	N/A	S
Proactive Diagnostics	N/A	N/A	N/A	N/A	S
CO ₂ Sensor Capable	N/A	N/A	N/A	N/A	S
IAQ Capable	N/A	N/A	N/A	N/A	S
SERVICE AND RELIABILITY FEATURES					
Service Test Mode	S	S	S	S	S
LED Fault and Status Lights	S	S	S	S	S
Fault Memory After Reset	S	S	S	S	S
Unit Performance Sentinel	S	S	S	S	S
Harness-Type Factory Wiring Connections	S	S	S	S	S
Fully Noise-Tested Design	S	S	S	S	S
CE Approval	S	S	S	S	S
Removable Low Voltage Connector	N/A	N/A	S	S	S
DDC/ENERGY MANAGEMENT FEATURES					
LONMark Compliant	N/A	S	N/A	S	S
BACnet Compliant	N/A	N/A	N/A	N/A	S
Johnson N2 Compliant	N/A	N/A	N/A	N/A	S
Modbus Compliant	N/A	N/A	N/A	N/A	S
Leaving Air and Water Temperature Sensor	N/A	S	N/A	S	S
Digital Wall Sensor	N/A	O	N/A	O	O

LEGEND

- | | |
|---|---------------------------------|
| Complete C — Complete C Control System | LON — LONMark Controller |
| DDC — Direct Digital Controls | N/A — Not Available |
| Deluxe D — Deluxe D Control System | O — Optional |
| IAQ — Indoor Air Quality | S — Standard |

Application data (cont)



Acoustical design

Sound power levels represent the sound as it is produced by the source, the WSHP unit, with no regard to attenuation between the source and the space. Acoustical design goals are necessary to provide criteria for occupied spaces where people can be comfortable and communicate effectively over the background noise of the air-conditioning system and other background noise sources.

Acoustical design goals are desirable sound pressure levels within a given conditioned space and are represented by noise criteria (NC) curves. The NC curve levels represent a peak over a full spectrum of frequencies. A high value in a low frequency band has the same effect on NC level as a lower value in a high frequency band. It is important that sound levels be balanced over the entire spectrum relative to the NC curve. The lower the NC criteria curve, the more stringent the room acoustical design must be to meet the design goals.

It is important to know how to convert NC levels from the unit ratings in terms of sound power (L_w). This conversion depends on the specifics of the acoustical environment of the installation.

The resulting calculations are compared to the NC curve selected for the area to assess the acoustical design.

Some of the factors that affect conversion of sound power to sound pressure and consequent NC level include:

- type of acoustical ceiling
- use of metal or flex duct
- absorption in the occupied space
- location in the occupied space
- open or closed layout plan
- use of open or ducted returns
- orientation of unit to occupant
- use of lined or unlined duct

WSHP sound control

The analysis of the projected sound level in the conditioned space caused by a WSHP unit located in a ceiling plenum is quite involved. The key is to have good sound power ratings (L_w) in dB on the equipment to determine the sound attenuation effect of the ductwork, ceiling and room. In combination with utilizing standard Aquazone™ equipment attenuating features or the advanced mute package features, suggestions for horizontal and vertical unit sound design are provided to design around the WSHP units.

Horizontal units

Use the following guidelines for layout of Aquazone horizontal units to minimize noise:

1. Obtain sound power ratings in accordance with latest standards from manufacturers to select quietest equipment.
2. Do not locate units over a space with a required NC of 40 or less. Instead, locate units above less sensitive noise areas such as above or in equipment rooms, utility closets, restrooms, storage rooms, or above corridors.
3. Provide at least 10 feet between WSHP units to avoid the additive effect of two noise sources.

4. Provide an acoustical pad underneath the WSHP unit in applications where the unit must be mounted above noise sensitive areas such as private offices or conference rooms. The pad attenuates radiated noise. Be sure the pad has an area at least twice that of the WSHP footprint.
5. Maximize the installed height above the suspended ceiling.
6. Be sure the WSHP unit is located at least 6 feet away from any ceiling return grille to prevent line-of-sight casing noise to reach the space below.
7. Suspend the WSHP unit from the ceiling with hangers that utilize spring or neoprene type isolators to reduce vibration transmission.
8. Utilize flexible electrical connections to the WSHP unit. **DO NOT USE NOT RIGID CONNECTIONS.**
9. Utilize flexible loop water and condensate piping connections to the WSHP unit.
10. Use a canvas duct connector to connect the WSHP discharge to the downstream duct system. This reduces vibration-induced noise.
11. Provide acoustic interior lining for the first 20 feet of discharge duct, or until the first elbow is reached. The elbow prevents line-of-site sound transmission in the discharge duct.
12. Provide turning vanes in ductwork elbows and tees to reduce air turbulence.
13. Size the sheet metal supply duct with velocities no greater than 1000 fpm.
14. Ensure ductwork is rigid.
15. Use round duct whenever possible to further reduce noise.
16. Allow at least 3 equivalent duct diameters of straight duct upstream and downstream of the unit before allowing any fittings, transitions, etc.
17. Seal all penetrations around duct entering the space.
18. Provide a 4-ft run-out duct made of flexible material to connect a diffuser to the supply trunk duct. The flex duct provides an “attenuating end-effect” and reduces duct-transmitted sound before it reaches the space. Typically a 6 dB sound reduction can be accomplished with the use of flex duct.
19. Locate the run-out duct balancing damper as far away from the outlet diffuser as possible. Locating the balancing damper at the trunk duct exit is the best location.
20. If return air is drawn through a ceiling plenum, provide an acoustically lined return duct elbow or “L” shaped boot at the WSHP to eliminate line-of-sight noise into the ceiling cavity and possible through ceiling return air grilles. Face the elbow or boot away from the nearest adjacent WSHP unit to prevent additive noise.
21. Do not hang suspended ceiling from the ductwork.



Vertical units

All guidelines established for horizontal units also apply for vertical units. In addition, since vertical units tend to be installed in small equipment rooms or closets, the following additional guidelines apply:

1. Mount the unit on a pad made of high-density sound absorbing material such as rubber or cork. Extend the pad beyond the WSHP unit footprint by at least 6 inches in each direction.
2. Since the unit returns airflow through a grille mounted in a closet door, provide a sound barrier or some other modification of the closet to prevent line-of-sight noise into the space.
3. Follow good duct design practice in sizing and locating the connection of the WSHP discharge to the supply duct system. Use an elbow with turning vanes and bent in the direction of the fan rotation to minimize turbulence. Make any duct transitions as smooth and as gradual as possible to again minimize turbulence and loss of fan static pressure.

Solenoid valves

In applications using variable flow pumping, solenoid valves can be field installed and operated from the control board in the Aquazone™ WSHP unit.

Freeze protection

Applications where systems are exposed to outdoor temperatures below freezing (32 F) must be protected from freezing. The most common method of protecting water systems from freezing is adding glycol concentrations into the water. Design care should be used when selecting both the type and concentrations of glycol utilized due to the following:

- Equipment and performance may suffer with high concentrations of glycol and other antifreeze solutions.
- Loss of piping pressure may increase greatly, resulting in higher pumping costs.
- Higher viscosity of the mixture may cause excess corrosion and wear on the entire system.
- Acidity of the water may be greatly increased, promoting corrosion.
- Glycol promotes galvanic corrosion in systems of dissimilar metals. The result is corrosion of one metal by the other, causing leaks.

WSHP Open sequence of operation

The WSHP Open multi-protocol controller will control mechanical cooling, heating and waterside economizer outputs based on its own space temperature input and set points. An optional CO₂ IAQ (indoor air quality) sensor mounted in the space can maximize the occupant comfort. The WSHP Open controller has its own hardware clock that is automatically set when the heat pump software is downloaded to the board. Occupancy types are described in the scheduling section below. The following sections describe the functionality of the WSHP Open multi-protocol controller. All point objects referred to in this sequence of operation will be referenced to the objects as viewed in the BACview⁶ handheld user interface.

Scheduling — Scheduling is used to start/stop the unit based on a time period to control the space temperature to specified occupied heating and cooling set points. The controller is defaulted to control by occupied set points all the time, until either a time schedule is configured with BACview⁶, Field Assistant, i-Vu[®] Open, or a third party control system to enable/disable the BAS (Building Automation System) on/off point. The local time and date must be set for these functions to operate properly. The occupancy source can be changed to one of the following:

Occupancy schedules — The controller will be occupied 24/7 until a time schedule has been configured using either Field Assistant, i-Vu Open, BACview⁶ or a third party control system to enable/disable the BAS on/off point. The BAS point can be disabled by going to Config, then Unit, then Occupancy Schedules and changing the point from enable to disable then clicking OK.

NOTE: This point must be enabled in order for the i-Vu Open, Field Assistant, or BACview⁶ control system to assign a time schedule to the controller.

Schedule_schedule — The unit will operate according to the schedule configured and stored in the unit. The schedule is accessible via the BACview⁶ Handheld tool, i-Vu Open, or Field Assistant control system. The daily schedule consists of a start/stop time (standard or 24-hour mode) and seven days of the week, starting with Monday and ending on Sunday. To enter a daily schedule, navigate to Config, then Sched, then enter BACview⁶ Admin Password (1111), then go to schedule_schedule. From here, enter either a Weekly or Exception schedule for the unit.

Occupancy input contact — The WSHP Open controller has the capability to use an external dry contact closure to determine the occupancy status of the unit. The Occupancy Schedules will need to be disabled in order to utilize the occupancy contact input.

NOTE: Scheduling can only be controlled from one source.

BAS (Building Automation System) on/off — A BAS system that supports network scheduling can control the unit through a network communication and the BAS scheduling function once the Occupancy Schedules have been disabled.

NOTE: Scheduling can either be controlled via the unit or the BAS, but not both.

Indoor fan — The indoor fan will operate in any one of three modes depending on the user configuration selected.

Fan mode can be selected as Auto, Continuous, or Always On. In Auto mode, the fan is in intermittent operation during both occupied and unoccupied periods. Continuous fan mode is intermittent during unoccupied periods and continuous during occupied periods. Always On mode operates the fan continuously during both occupied and unoccupied periods. In the default mode, Continuous, the fan will be turned on whenever any one of the following is true:

- The unit is in occupied mode as determined by its occupancy status.
- There is a demand for cooling or heating in the unoccupied mode.
- There is a call for dehumidification (optional).

When power is reapplied after a power outage, there will be a configured time delay of 5 to 600 seconds before starting the fan. There are also configured fan delays for Fan On and Fan Off. The Fan On delay defines the delay time (0 to 30 seconds; default 10) before the fan begins to operate after heating or cooling is started while the Fan Off delay defines the delay time (0 to 180 seconds; default 45) the fan will continue to operate after heating or cooling is stopped. The fan will continue to run as long as the compressors, heating stages, or the dehumidification relays are on. If the SPT failure alarm or condensate overflow alarm is active; the fan will be shut down immediately regardless of occupancy state or demand.

Automatic fan speed control — The WSHP Open controller is capable of controlling up to three fan speeds using the ECM (electronically commutated motor). The motor will operate at the lowest speed possible to provide quiet and efficient fan operation with the best latent capability. The motor will increase speed if additional cooling or heating is required to obtain the desired space temperature set point. The control increases the motor's speed as the space temperature rises above the cooling or below the heating set point. The amount of space temperature increase above or below the set point required to increase the fan speed is user configurable in the set point. Also, the control will increase the fan speed as the supply-air temperature approaches the configured minimum or maximum limits.

Fan speed control (during heating) — Whenever heat is required and active, the control continuously monitors the supply-air temperature to verify it does not rise above the configured maximum heating SAT limit (110 F default). As the SAT approaches this value, the control will increase the fan speed as required to ensure the SAT will remain within the limit. This feature provides the most quiet and efficient operation by operating the fan at the lowest speed possible.

Fan speed control (during cooling) — Whenever mechanical cooling is required and active, the control continuously monitors the supply-air temperature to verify it does not fall below the configured minimum cooling SAT limit (50 F default). As the SAT approaches this value, the control will increase the fan speed as required to ensure the SAT will remain within the limit. The fan will operate at lowest speed to maximize latent capacity during cooling.

Cooling — The WSHP Open controller will operate one or two stages of compression to maintain the desired cooling set point. The compressor outputs are controlled by the PI (proportional-integral) cooling loop and cooling stages capacity algorithm. They will be used to calculate the desired number of stages needed to satisfy the space by comparing the space temperature (SPT) to the appropriate cooling set point. The water side economizer, if applicable, will be used for first stage cooling in addition to the compressor(s). The following conditions must be true in order for the cooling algorithm to run:

- Cooling is set to Enable.
- Heating mode is not active and the compressor time guard has expired.
- Condensate overflow input is normal.
- If occupied, the SPT is greater than the occupied cooling set point.
- Space temperature reading is valid.
- If unoccupied, the SPT is greater than the unoccupied cooling set point.
- If economizer cooling is available and active and the economizer alone is insufficient to provide enough cooling.
- OAT (if available) is greater than the cooling lockout temperature.

If all the above conditions are met, the compressors will be energized as required, otherwise they will be deenergized. If cooling is active and should the SAT approach the minimum SAT limit, the fan will be indexed to the next higher speed. Should this be insufficient and if the SAT falls further (equal to the minimum SAT limit), the fan will be indexed to the maximum speed. If the SAT continues to fall 5° F below the minimum SAT limit, all cooling stages will be disabled.

During Cooling mode, the reversing valve output will be held in the cooling position (either B or O type as configured) even after the compressor is stopped. The valve will not switch position until the Heating mode is required.

The configuration screens contain the minimum SAT parameter as well as cooling lockout based on outdoor-air temperature (OAT). Both can be adjusted to meet various specifications.

There is a 5-minute off time for the compressor as well as a 5-minute time delay when staging up to allow the SAT to achieve a stable temperature before energizing a second stage of capacity. Likewise, a 45-second delay is used when staging down.

After a compressor is staged off, it may be restarted again after a normal time-guard period of 5 minutes and if the supply-air temperature has increase above the minimum supply-air temperature limit.

The WSHP Open controller provides a status input to monitor the compressor operation. The status is monitored to determine if the compressor status matches the commanded state. This input is used to determine if a refrigerant safety switch or other safety device has tripped and caused the compressor to stop operating normally. If this should occur, an alarm will be generated to indicate the faulted compressor condition.

Heating — The WSHP Open controller will operate one or two stages of compression to maintain the desired heating set point. The compressor outputs are controlled by the heating PI (proportional-integral) loop and heating stages capacity algorithm. They will be used to calculate the desired number of stages needed to satisfy the space by comparing the space temperature (SPT) to the appropriate heating set point. The following conditions must be true in order for the heating algorithm to run:

- Heating is set to Enable.
- Cooling mode is not active and the compressor time guard has expired.
- Condensate overflow input is normal.
- If occupied, the SPT is less than the occupied heating set point.
- Space temperature reading is valid.
- If unoccupied, the SPT is less than the unoccupied heating set point.
- OAT (if available) is less than the heating lockout temperature.

If all the above conditions are met, the heating outputs will be energized as required, otherwise they will be deenergized. If the heating is active and should the SAT approach the maximum SAT limit, the fan will be indexed to the next higher speed. Should this be insufficient, and the SAT rises further reaching the maximum heating SAT limit, the fan will be indexed to the maximum speed. If the SAT still continues to rise 5° F above the maximum limit, all heating stages will be disabled.

During Heating mode, the reversing valve output will be held in the heating position (either B or O type as configured) even after the compressor is stopped. The valve will not switch position until the Cooling mode is required.

The configuration screens contain the maximum SAT parameter as well as heating lockout based on outdoor-air temperature (OAT); both can be adjusted to meet various specifications.

There is a 5-minute off time for the compressor as well as a 5-minute time delay when staging up to allow the SAT to achieve a stable temperature before energizing a second stage of capacity. Likewise, a 45-second delay is used when staging down.

After a compressor is staged off, it may be restarted again after a normal time-guard period of 5 minutes and if the supply-air temperature has fallen below the maximum supply air temperature limit.

The WSHP Open controller provides a status input to monitor the compressor operation. The status is monitored to determine if the compressor status matches the commanded state. This input is used to determine if a refrigerant safety switch or other safety device has tripped and caused the compressor to stop operating normally. If this should occur, an alarm will be generated to indicate the faulted compressor condition. Also, if auxiliary heat is available (see below), the auxiliary heat will operate to replace the reverse cycle heating and maintain the space temperature as required.

Auxiliary heat — The WSHP Open controller can control a two-position, modulating water, or steam valve

Controls (cont)



connected to a coil on the discharge side of the unit and supplied by a boiler or a single-stage ducted electric heater in order to maintain the desired heating set point. Should the compressor capacity be insufficient or a compressor failure occurs, the auxiliary heat will be used. Unless the compressor fails, the auxiliary heat will only operate to supplement the heat provided by the compressor if the space temperature falls more than one degree below the desired heating set point (the amount is configurable). The heat will be controlled so the SAT will not exceed the maximum heating SAT limit.

Auxiliary modulating hot water/steam heating reheat — The control can modulate a hot water or steam valve connected to a coil on the discharge side of the unit and supplied by a boiler in order to maintain the desired heating set point should the compressor capacity be insufficient or a compressor failure occurs. Unless a compressor fault condition exists, the valve will only operate to supplement the heat provided by the compressor if the space temperature falls more than one degree below the desired heating set point. The valve will be controlled so the SAT will not exceed the maximum heating SAT limit.

Two-position hot water/steam heating reheat — The control can operate a two-position, NO or NC, hot water or steam valve connected to a coil on the discharge side of the unit and supplied by a boiler in order to maintain the desired heating set point should the compressor capacity be insufficient or a compressor failure occurs. Unless a compressor fault condition exists, the valve will only open to supplement the heat provided by the compressor if the space temperature falls more than one degree below the desired heating set point. The valve will be controlled so the SAT will not exceed the maximum heating SAT limit. The heat stage will also be subject to a 2-minute minimum OFF time to prevent excessive valve cycling.

Single stage electric auxiliary heat — The control can operate a field-installed single stage of electric heat installed on the discharge side of the unit in order to maintain the desired heating set point should the compressor capacity be insufficient or a compressor failure occurs. Unless a compressor fault condition exists, the heat stage will only operate to supplement the heat provided by the compressor if the space temperature falls more than one degree below the desired heating set point. The heat stage will be controlled so the SAT will not exceed the maximum heating SAT limit. The heat stage will also be subject to a 2-minute minimum OFF time to prevent excessive cycling.

Indoor air quality (IAQ) and demand controlled ventilation (DCV) — If the optional indoor air quality sensor is installed, the WSHP Open controller can maintain indoor air quality via a modulating OA damper providing demand controlled ventilation. The control operates the modulating OA damper during occupied periods. The control monitors the CO₂ level and compares it to the configured set points, adjusting the ventilation rate as required. The control provides proportional ventilation to meet the requirements of ASHRAE specifications by providing a base ventilation rate and then increasing the rate as the CO₂ level increases. The control will begin to proportionally increase ventilation when the CO₂ level rises above the start

ventilation set point and will reach the full ventilation rate when the CO₂ level is at or above the maximum set point. A user-configurable minimum damper position ensures that proper base ventilation is delivered when occupants are not present. The IAQ configurations can be accessed through the configuration screen. The following conditions must be true in order for this algorithm to run:

- Damper control is configured for DCV.
- The unit is in an occupied mode.
- The IAQ sensor reading is greater than the DCV start control set point.

The control has four user adjustable set points: DCV start control set point, DCV maximum control set point, minimum damper position, and DCV maximum damper position.

Two-position OA damper — The control can be configured to operate a ventilation damper in a two-position ventilation mode to provide the minimum ventilation requirements during occupied periods.

Waterside economizer — The WSHP Open controller has the capability of providing modulating or two-position water economizer operation (for a field-installed economizer coil mounted to the entering air side of the unit and connected to the condenser water loop) in order to provide free cooling (or preheating) when water conditions are optimal. Water economizer settings can be accessed through the equipment status screen. The following conditions must be true for economizer operation:

- SAT reading is available.
- EWT reading is available.
- If occupied, the SPT is greater than the occupied cooling set point or less than the occupied heating set point and the condenser water is suitable.
- Space temperature reading is valid.
- If unoccupied, the SPT is greater than the unoccupied cooling set point or less than the unoccupied heating set point and the condenser water is suitable.

Modulating water economizer control — The control has the capability to modulate a water valve to control condenser water flowing through a coil on the entering air side of the unit.

Cooling — The purpose is to provide an economizer cooling function by using the water loop when the entering water loop temperature is suitable (at least 5° F below space temperature). If the water loop conditions are suitable, then the valve will modulate open as required to maintain a supply air temperature that meets the load conditions. Should the economizer coil capacity alone be insufficient for a period greater than 5 minutes, or should a high humidity condition occur, then the compressor will also be started to satisfy the load. Should the SAT approach the minimum cooling SAT limit, the economizer valve will modulate closed during compressor operation.

Heating — Additionally, the control will modulate the water valve should the entering water loop temperature be suitable for heating (at least 5° F above space temperature) and heat is required. The valve will be controlled in a similar manner except to satisfy the heating requirement. Should the economizer coil capacity alone be insufficient

to satisfy the space load conditions for more than 5 minutes, then the compressor will be started to satisfy the load. Should the SAT approach the maximum heating SAT limit, the economizer valve will modulate closed during compressor operation.

Two-position water economizer control — The control has the capability to control a NO or NC, two-position water valve to control condenser water flow through a coil on the entering air side of the unit.

Cooling — The purpose is to provide a cooling economizer function directly from the condenser water loop when the entering water loop temperature is suitable (at least 5° F below space temperature). If the optional coil is provided and the water loop conditions are suitable, then the valve will open to provide cooling to the space when required. Should the capacity be insufficient for a period greater than 5 minutes, or should a high humidity condition occur, then the compressor will be started to satisfy the load. Should the SAT reach the minimum cooling SAT limit, the economizer valve will close during compressor operation.

Heating — Additionally, the economizer control will open the water valve should the entering water loop temperature be suitable for heating (at least 5° F above space temperature) and heat is required. The valve will be controlled in a similar manner except to satisfy the heating requirement. Should the coil capacity be insufficient to satisfy the space load for more than 5 minutes, then the compressor will be started to satisfy the load. Should the SAT reach the maximum heating SAT limit, the economizer valve will close during compressor operation.

Demand limit — The WSHP Open controller has the ability to accept three levels of demand limit from the network. In response to a demand limit, the unit will decrease

its heating set point and increase its cooling set point to widen the range in order to immediately lower the electrical demand. The amount of temperature adjustment in response is user adjustable for both heating and cooling and for each demand level. The response to a particular demand level may also be set to zero.

Condenser water linkage — The control provides optimized water loop operation using an universal controller (UC) open loop controller. Loop pump operation is automatically controlled by WSHP equipment occupancy schedules, unoccupied demand and tenant override conditions. Positive pump status feedback prevents nuisance fault trips. The condenser water linkage operates when a request for condenser water pump operation is sent from each WSHP to the loop controller. This request is generated whenever any WSHP is scheduled to be occupied, is starting during optimal start (for warm-up or pull down prior to occupancy), there is an unoccupied heating or cooling demand, or a tenant pushbutton override. At each WSHP, the water loop temperature and the loop pump status is given. The WSHP will NOT start a compressor until the loop pumps are running or will shutdown the compressors should the pumps stop. This prevents the WSHP from operating without water flow and thus tripping out on refrigerant pressure, causing a lockout condition. The WSHP Open controller will prevent this from occurring. Also, the loop controller can be configured to start the pumps only after a configurable number of WSHPs are requesting operation (from 1-"N"). This can be used to prevent starting the entire loop operation for only one WSHP. Meanwhile, the WSHPs will not operate if the loop pump status is off and therefore the WSHP compressor will not run.

Guide specifications



Single-Stage Water Source Heat Pumps with Puron® Refrigerant (R-410A)

HVAC Guide Specifications

Size Range: **5,800 to 66,600 Btuh**

Cooling Capacity

4,900 to 77,000 Btuh

Heating Capacity

Carrier Model Number: **50P1H, 50P1V**

Part 1 — General

1.01 SYSTEM DESCRIPTION

- A. Single package horizontally and vertically mounted water source heat pumps with Puron® refrigerant (R-410A) and electronic controls.
- B. Equipment shall be completely assembled, piped and internally wired. Capacities and characteristics as listed in the schedule and the guide specifications that follow.

1.02 QUALITY ASSURANCE

- A. All equipment listed in this section must be rated and certified in accordance with AHRI/ISO and ETL listed to UL standard 1995. The units shall have AHRI/ISO and ETL labels.
- B. All units shall be fully quality tested by factory run testing under normal operating conditions and water flow rates as described herein. Quality control system shall automatically perform via computer: triple leak check, pressure tests, evacuate and accurately charge system, perform detailed heating and cooling mode tests, and quality cross check all operational and test conditions to pass/fail data base. A detailed report card will ship with each unit displaying all test performance data.
NOTE: If unit fails on any cross check, system shall not allow unit to ship.
- C. Serial numbers will be recorded by factory and furnished to contractor on report card for ease of unit warranty status. Units tested without water flow are not acceptable. Units shall be prewired and pre-charged in factory.

Part 2 — Product

2.01 EQUIPMENT

A. General:

Units shall be supplied completely factory built for an entering water temperature range from 60 to 95 F as standard. Units may consist of rotary or scroll compressor, PSC (permanent split capacitor) fan motor and blower and refrigerant circuit as indicated on the equipment schedule. Equivalent units from other manufacturers can be proposed provided approval to bid is given 10 days prior to bid closing.

B. Unit Cabinets:

1. Horizontal Units:

- a. Horizontal units shall have one of the following airflow arrangements: left inlet/right discharge; right inlet/left discharge; left

inlet/back discharge; or right inlet/back discharge as shown on the plans.

- b. Horizontal units must have the ability to be field convertible from side to back or back to side discharge with no additional parts or unit structure modification. Units will have factory-installed hanger brackets with rubber isolation grommets packaged separately.

2. Vertical Units:

Vertical units shall have one of the following air flow arrangements: left return/top discharge, right return/top discharge, front return/top discharge as shown on the plans.

3. If units with these arrangements are not used, the contractor is responsible for any extra costs incurred by other trades.
4. All units (horizontal and vertical) must have a minimum of three access panels for serviceability of compressor compartment. Units having only one access panel to compressor, heat exchangers, expansion device, or refrigerant piping shall not be acceptable.
5. Standard cabinet panel insulation must meet NFPA 90A requirements, air erosion and mold growth limits of UL-181, stringent fungal resistance test per ASTM C1071 and ASTM G21, and shall meet zero level bacteria growth per ASTM G22. Unit insulation must meet these stringent requirements or unit(s) will not be accepted.
6. Cabinets shall have separate holes and knockouts for entrance of line voltage and low voltage control wiring.
7. All factory-installed wiring passing through factory knockouts and openings shall be protected from sheet metal edges at openings by plastic ferrules.
8. Contractor must ensure that units can be easily removed for servicing and coordinate locations of electrical conduit and lights with the electrical contractor.

C. Compressor:

1. Compressor section interior surfaces shall be lined with 1/2 in. thick, dual density, 1 1/2 lb per cubic ft acoustic type fiberglass insulation. Air-handling section interior surfaces shall be lined with 1/2 in. thick, single density, 1 1/2 lb per cubic ft foil-backed fiber insulation for ease of cleaning.
2. Insulation placement shall be designed in a manner that will eliminate any exposed edges to prevent the introduction of glass fibers into the airstream. Units without foil-backed insulation in the air-handling section will not be accepted.
3. The compressor shall have a dual level vibration isolation system.



4. The compressor will be mounted on computer-selected vibration isolation springs to a large heavy gage compressor mounting tray plate, which is then isolated from the cabinet base with rubber grommets for maximized vibration attenuation.
5. Compressor shall be located in an insulated compartment away from airstream to minimize sound transmission.
6. Compressor shall have thermal overload protection.
7. The heat pumps shall be fabricated from heavy gage galvanized steel with powder coat paint finish. Both sides of the steel shall be painted for added protection.
8. All units must have an insulated panel separating the fan compartment from the compressor compartment.
9. Units with the compressor in the airstream are not acceptable.

D. Fan and Motor Assembly:

1. Blower shall have inlet rings to allow removal of wheel and motor from one side without removing housing.
2. The fan motor shall be 3-speed, permanently lubricated, PSC (permanent split capacitor) type with internal thermal overload protection.
3. The fan motor shall be isolated from the housing by rubber grommets.
4. The motor shall be permanently lubricated and have thermal overload protection.
5. A special dehumidification mode shall be provided to allow lower airflows in cooling for better dehumidification. The dehumidification mode shall be selectable via a jumper on the control board or may be controlled externally from a humidistat.
6. Airflow/static pressure rating of the unit shall be based on a wet coil and a clean filter in place. Ratings based on a dry coil and/or no filter, or on an ESP (external static pressure) less than 0.50 in. wg shall NOT be acceptable.

E. Refrigerant Circuit:

1. All units shall contain a Puron® refrigerant (R-410A) sealed circuit including a high-efficiency Copeland UltraTech™ single-stage compressor designed for heat pump operation, a thermostatic expansion valve for refrigerant metering, an enhanced corrugated aluminum lanced fin and rifled copper tube refrigerant to air heat exchanger, reversing valve, coaxial (tube-in-tube) refrigerant to water heat exchanger, and safety controls, including a high-pressure switch, low-pressure switch (loss of charge), water coil low temperature sensor, and air coil low temperature sensor.

2. Access fittings shall be factory-installed on high and low pressure refrigerant lines to facilitate field service.
3. Refrigerant metering shall be accomplished by thermostatic expansion valve only.

F. Drain Pan:

1. The drain pan shall be constructed of epoxy powder, painted, galvanized steel to inhibit corrosion. This corrosion protection system shall meet the stringent 1000-hour salt spray test per ASTM B117. If plastic type material is used, it must be HDPE (high-density polyethylene) to avoid thermal cycling shock stress failure over the lifetime of the unit.
2. Drain pan shall be fully insulated.
3. Drain outlet shall be located at pan as to allow complete and unobstructed drainage of condensate. Drain outlet for horizontal units shall be connected from pan directly to FPT fitting. No hidden internal tubing extensions from pan outlet extending to unit casing (that can create drainage problems) will be accepted.
4. The unit as standard will be supplied with solid-state electronic condensate overflow protection. A mechanical float switch will be used with the WSHP Open multiple protocol controller option.
5. Vertical units shall be furnished with a PVC slip condensate drain connection and an internal factory-installed condensate trap. If units without an internal trap are used, the contractor is responsible for any extra costs to field install these provisions, and/or the extra costs for the subcontractor to install these provisions.

G. Filter:

1. Units shall have a factory-installed 1 in. wide filter bracket for filter removal from either side. Units shall have a 1 in. thick throwaway type fiberglass filter.
2. The contractor shall purchase one spare set of filters and replace factory shipped filters on completion of start-up.
3. Filters shall be standard sizes. If units utilize non-standard filter sizes, then the contractor shall provide 12 spare filters for each unit.

H. Thermostatic Expansion Valve:

1. Expansion valves shall be dual port balanced types with external equalizer for optimum refrigerant metering.
2. Units shall be designed and tested for operating ranges of entering water temperatures from 20 to 120 F.
3. Reversing valve shall be four-way solenoid activated refrigerant valve, which shall default to heating mode should the solenoid fail to function. If the reversing valve solenoid defaults to cooling mode, an additional low temperature

Guide specifications (cont)



thermostat must be provided to prevent over-cooling an already cold room.

I. Controls and Safeties:

1. Electrical:

- a. A control box shall be located within the unit compressor compartment and shall contain a 50 va transformer, 24-volt activated, 2 or 3-pole compressor contactor, terminal block for thermostat wiring and solid-state controller for complete unit operation.
- b. Reversing valve and fan motor wiring shall be routed through this electronic controller.
- c. Units shall be name-plated for use with time-delay fuses or HACR circuit breakers. Unit controls shall be 24-volt and provide heating or cooling as required by the remote thermostat/sensor.

2. Unit Controls:

- a. Safety controls including a high-pressure switch, a low-pressure sensor, and a low water and low air temperature sensor. Access fittings shall be factory installed on high and low pressure refrigerant lines to facilitate field service.
- b. Activation of any safety device shall prevent compressor operation via a microprocessor lockout circuit. The lockout shall be reset at the thermostat or at the contractor-supplied disconnect switch.
- c. Units which may be reset only at the disconnect switch only shall not be acceptable.

3. Complete C Controls:

The standard Complete C electronic control system shall interface with a heat pump (Y,O) wall thermostat (mechanical or electronic). The control system microprocessor board shall be specifically designed to protect against building electrical system noise contamination, EMI, and RFI interference. The control system shall have the following features:

- a. 50 va transformer.
- b. Performance Monitor (PM). The PM warns when the heat pump is running inefficiently.
- c. Anti-short cycle time delay on compressor operation time delay shall be 5 minutes minimum.
- d. Random start on power up mode.
- e. Low voltage protection.
- f. High voltage protection.
- g. Unit shutdown on high or low refrigerant pressures.
- h. Unit shutdown on low water temperature.
- i. Water coil freeze protection (selectable for water or antifreeze).
- j. Air coil freeze protection (check filter switch).
- k. Condensate overflow shutdown.

- l. Option to reset unit at thermostat or disconnect. Fault type shall be retained in memory if reset at thermostat.
- m. Automatic intelligent reset. Unit shall automatically reset 5 minutes after trip if the fault has cleared. Should a fault reoccur 3 times sequentially, lockout requiring manual reset will occur.
- n. Ability to defeat time delays for servicing.
- o. Light-emitting diodes (LED) to indicate high pressure, low pressure, low voltage, high voltage, air/water freeze protection, condensate overflow and control status.
- p. The low-pressure switch SHALL NOT be monitored for the first 90 seconds after a compressor start command to prevent nuisance safety trips.
- q. Remote fault type indication at thermostat.
- r. Selectable 24-v or pilot duty dry contact alarm output.
- s. 24-v output to cycle a motorized water valve with compressor contactor.
- t. Electric heat output to control two stages of electric heat (emergency heat).
- u. Service test mode for troubleshooting and service.
- v. Unit Performance Sentinel (UPS). The UPS warns when the heat pump is running inefficiently.

Units not providing the 8 safety protections of anti-short cycle, low voltage, high voltage, high refrigerant pressure, low pressure (loss of charge), air coil freeze, water coil freeze, and condensate overflow protections will not be accepted.

4. Deluxe D Controls:

Optional electronic Deluxe D control shall have all the features of the Complete C control with the following additional features:

- a. 75 va transformer.
- b. A removable thermostat connector.
- c. Random start on return from night setback.
- d. Intelligent reversing valve operation for extended life and quiet operation.
- e. Night setback control from low temperature thermostat, with 2-hour override initiated by a momentary signal from the thermostat.
- f. Dry contact night setback output for digital night setback thermostats.
- g. Ability to work with heat/cool (Y, W) thermostats.
- h. Ability to work with heat pump thermostats using O or B reversing valve control.
- i. Single grounded wire to initiate night setback, or emergency shutdown.

- j. Boilerless system control can switch automatically to electric heat at low loop water temperature.
 - k. Dehumidistat input providing fan control for dehumidification operation via the Ideal-Humidity™ system.
 - l. Multiple units connected to one sensor providing communication for up to 3 water source heat pumps.
 - m. Selection of boilerless changeover temperature set point.
 - n. Compressor relay staging for dual stage units or in master/slave applications.
- Units not having automatic low sensible heat ratio cooling will not be accepted; as an alternate, a hot gas reheat coil may be provided with control system for automatic activation.
5. WSHP Open Multiple Protocol Control:
- Units shall have all the features above (either C or D boards) and the state of the art WSHP Open multiple protocol interface board. All point objects will have the ability to be viewed in the BACview⁶ Handheld user interface. This will permit all units to be daisy chain connected by a 2-wire twisted pair shielded cable. The following points must be available at a central or remote computer location:
- a. space temperature
 - b. leaving water temperature
 - c. discharge air temperature
 - d. command of space temperature set point
 - e. cooling status
 - f. heating status
 - g. low temperature sensor alarm
 - h. high pressure switch alarm
 - i. fan on/off position of space thermostat
 - j. unoccupied/occupied command
 - k. cooling demand
 - l. heating demand
 - m. fan "ON/AUTO" command
 - n. fault prevention with auto reset
 - o. itemized fault code viewed with BACview interface
- Additional WSHP Open multiple protocol control features shall include:
- a. two-position OA damper
 - b. modulating OA damper with DCV
 - c. auxiliary modulating hot water/steam heating
 - d. two-position hot water/steam heating
 - e. single stage electric auxiliary heat
 - f. auto fan speed control (heating/cooling)
 - g. power fail restart delay
 - h. dehumidification
 - i. modulating water economizer control
 - j. two-position water economizer control
6. PremierLink™ Controller:
- This optional control will function with CCN (Carrier Comfort Network®) and ComfortVIEW™ software. It shall also be compatible with ComfortLink™ controllers. It shall be ASHRAE 62 compliant and Internet ready. It shall accept a CO₂ sensor in the conditioned space and be demand controlled ventilation (DCV) ready. The communication rate must be 38.4K or faster. It shall include an integrated economizer controller.
7. LonWorks Interface System:
- Units shall have all features listed above (either Complete C or Deluxe D) and the control board shall be supplied with a LonWorks interface board, which is LONMark certified. This will permit all units to be daisy chained via a 2-wire twisted pair shielded cable. The following points must be available at a central or remote computer location:
- a. space temperature
 - b. leaving-water temperature
 - c. discharge-air temperature
 - d. command of space temperature set point
 - e. cooling status
 - f. heating status
 - g. low temperature sensor alarm
 - h. low pressure sensor alarm
 - i. high pressure switch alarm
 - j. condensate sensor alarm
 - k. high/low voltage alarm
 - l. fan "ON/AUTO" position of space thermostat
 - m. unoccupied/occupied command
 - n. cooling command
 - o. heating command
 - p. fan "ON/AUTO" command
 - q. fault reset command
 - r. itemized fault code revealing reason for specific shutdown fault (any one of 7)
- This option also provides the upgraded 75 va control transformer with load side short circuit and overload protection via a built in circuit breaker.
- J. Piping:
- 1. Supply and return water connections shall be copper FPT fittings and shall be securely mounted flush to the cabinet corner post allowing for connection to a flexible hose without the use of a back-up wrench.

Guide specifications (cont)



2. All water connections and electrical knockouts must be in the compressor compartment corner post as to not interfere with the serviceability of unit. Contractor shall be responsible for any extra costs involved in the installation of units that do not have this feature.
- K. Solid-State Permanent Split Capacitor (PSC) Fan Control Board:
1. Airflow selection shall be accomplished via 3 jumper switches on the PSC control board. Actual airflow shall be indicated by the cfm LED with each 100 cfm being represented by one flash of the LED.
 2. Airflow shall be automatically maintained ($\pm 5\%$) by the PSC motor regardless of external static pressure up to its maximum output capacity.
 3. A jumper shall allow selection of a special dehumidification mode, which reduces airflow in cooling by 25% to increase the latent capacity of the unit. A terminal shall be provided on the control board to allow an external humidistat to activate dehumidification mode.
- L. Remote Service Sentinel (Complete C or Deluxe D):
1. Solid-state control system shall communicate with thermostat to display (at the thermostat) the unit status, fault status, and specific fault condition, as well as retrieve previously stored fault that caused unit shutdown.
 2. The remote service sentinel allows building maintenance personnel or service personnel to diagnose unit from the wall thermostat.
 3. The control board shall provide a signal to the thermostat fault light, indicating a lockout.
 4. Upon cycling the G (fan) input 3 times within a 60-second time period, the fault light shall display the specific code as indicated by a sequence of flashes. A detailed flashing code shall be provided at the thermostat LED to display unit status and specific fault status such as over/under voltage fault, high pressure fault, low pressure fault, low water temperature fault, condensate overflow fault, etc.
 5. Units that do not provide this remote service sentinel shall not be acceptable.
- M. Special Features:
1. Cupronickel coaxial water-to-refrigerant heat exchangers are available for higher corrosion protection.
 2. The sound attenuation (mute) package consists of high technology sound attenuating materials strategically applied to the cabinet, in addition to the standard system, to further dampen sound.
 3. Extended range is available for units operating with entering water temperatures below dew point. Extended entering water temperatures range from 20 to 120 F.
 4. A two-way motorized water control valve shall operate in conjunction with the compressor to shut off or turn on water to the unit.
 5. Water circuit options shall provide internally mounted 2.5 or 3.0 gpm per ton automatic flow regulating valves.
 6. The permanent split capacitor (PSC) high-static blower motor shall increase unit capacity through the use of a high-static blower motor.
 7. Aquazone™ Thermostat Controls:
 - a. Programmable multi-stage thermostat offers 7-day clock, holiday scheduling, large backlit display and remote sensor capability.
 - b. Programmable 7-day light-activated thermostat offers occupied comfort settings with lights on, unoccupied energy savings with lights off.
 - c. Programmable 7-day flush-mount thermostat offers locking coverplate with tamper proof screws, flush to wall mount, dual point with adjustable deadband, O or B terminal, and optional remote sensor.
 - d. Programmable 5-day thermostat offers 2-stage heat/2-stage cool, auto changeover, 5-minute built-in compressor protection, locking cover included.
 - e. Non-programmable thermostat offers 2-stage heat/2-stage cool, auto changeover, 5-minute built-in compressor protection, locking cover included.
 8. Loop controller with six stages (2 stages for heating and 4 stages for heat rejection) is available.
 9. The filter rack (1-in.) enhances the filtration system of the water source heat pump.
NOTE: Filter rack does not include filters.
 10. Fire-rated hose kits include a fixed MPT on one end and a swivel with an adapter on the other end. Hose kits can be either stainless steel or galvanized.
 11. Ball valves (brass body) shut off and balance water flow. Valves are available with memory, memory stop, and pressure temperature ports.
 12. Y strainers (bronze body) are “Y” type configuration with a brass cap and stainless steel strainer screen. Maximum operating pressure rating of strainers is 450 psi.
 13. Solenoid valves (brass body) provide slow operation for quiet system application.
 14. Hose kit assemblies include a ported ball valve with pressure temperature (P/T) plug ports and flexible stainless steel hose with swivel and nipple. Return hose includes a ball valve, preset measure flow (gpm) with two P/T ports, flexible stainless steel hose with a swivel and nipple.



15. Multiple-protocol WSHP Open controller remote sensors for Aquazone flush-mount thermostats and DDC control options. Only Carrier sensors can be used with the WSHP Open controller. Sensors are available as follows:
 - a. SPT Standard offers space temperature sensor with communication port.
 - b. SPT Plus offers space temperature sensor with set point adjust, local override with indicating light and communication port.
 - c. SPT Pro offers space temperature sensor with LCD display, set point adjust, local override, alarm icon, outside air, and unit status with heating and cooling set points.
 - d. SPT Pro+ offers space temperature sensor with LCD display, set point adjust, local override, alarm icon, outside air, unit status with heating and cooling set points, and fan speed control.
16. PremierLink™ accessories provide a fully integrated DDC system. Accessories include supply air temperature sensors, communicating room sensors, CO₂ sensors, and linkage thermostats.
17. An Aquazone™ system control panel as specified in 50RLP Product Data (525-00040) is available.
18. LON wall sensors are available in 3 models: sensor only, sensor with status override indicator, and sensor with set point, status adjustment override, and digital LCD display.

