

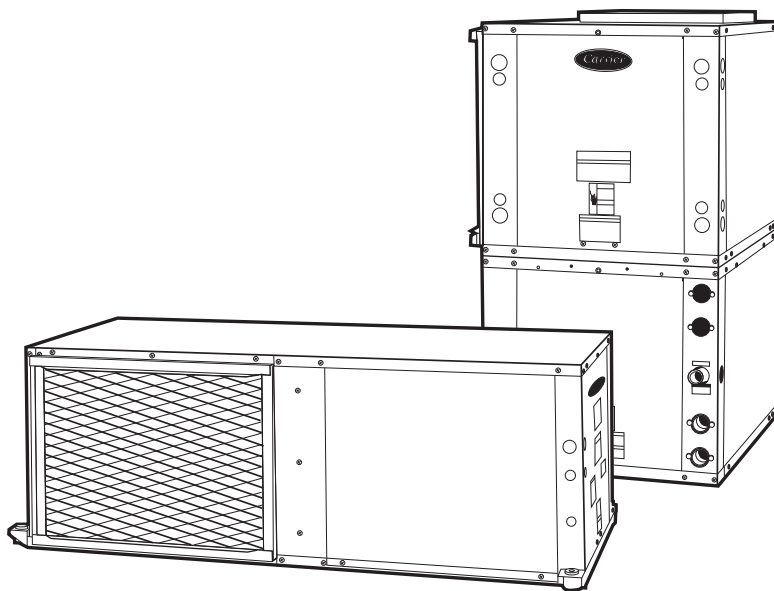

# Product Data

# AQUAZONE™ 50PCH006-060, 50PCV006-060 Compact Water Source Heat Pumps with PURON® Refrigerant (R-410A)

1/2 to 5 Nominal Tons



Single-package horizontally and vertically mounted water source heat pumps (WSHPs) with solid-state controls.

- Compact cabinet design
- Performance certified to AHRI/ISO/ASHRAE 13256-1
- Suitable for geothermal (with extended range option) and boiler/tower use with an operating temperature range of 20 to 120 F
- Three service panels for compressor section
- Meets new ASHRAE 90.1 performance requirements
- Backward compatibility for replacing older units from various manufacturers
- Puron® refrigerant (R-410A)
- Flexible and reliable multiple protocol WSHP Open controller can use BACnet\*, Modbus†, and N2 protocols for integrating energy efficiency and precise unit control
- Mute package for quiet operation

## Features/Benefits

**Carrier's Aquazone WSHPs are an efficient, compact alternative for all boiler/tower and retrofit applications**

### Operating efficiency

Aquazone WSHP units offer cooling EERs (energy efficiency ratios) to 24.5 and heating COPs (coefficients of performance) to 5.

**ASHRAE  
90.1  
COMPLIANT**

  
**Puron**®  
the environmentally sound refrigerant

# Features/Benefits (cont)



All efficiency ratings stated are in accordance with standard conditions under AHRI (Air-Conditioning, Heating, and Refrigeration Institute)/ISO (International Organization for Standardization)/ASHRAE (American Society of Heating, Refrigerating and Air Conditioning Engineers) Standard 13256-1 and provide among the highest ratings in the industry, exceeding ASHRAE 90.1 Energy Standards.

## High quality construction and testing

All units are manufactured to meet extensive quality control standards. An automated control system provides continuous monitoring of each unit and performs quality control checks as equipment progresses through the production process. Standard construction features of the Aquazone™ units include:

**Cabinet** — Heavy gage galvanized sheet metal cabinet construction enables part standardization (i.e., minimal number of parts) and modular design. Cabinet interior surfaces are lined with 1/2 in. thick, 1<sup>3</sup>/<sub>4</sub> lb acoustic type insulation. Sheet metal surfaces are treated for maximum corrosion protection to ensure resilience for long term vitality. Compact cabinet dimensions fit tight space limitations in both horizontal and vertical configurations.

**Compressor** — Aquazone standard efficiency units include a rotary compressor in sizes 006-018 and a scroll compressor in size 024-060 units. Compressors are mounted on an isolated system (i.e., from the cabinet) that maximizes vibration isolation and

minimizes transmission to the unit structure.

**Blower and motor assembly** — Permanent split capacitor (PSC) three-speed (two-speed for 575 v) blowers are provided with all units to satisfy many air distribution applications. Blower upgrades are available for high-static conditions. Fan speed control allows reduced sound operation. Blower motors operate at lower temperatures to help improve the reliability of the water source heat pump.

**Refrigeration/water circuit** — Most units have a sealed refrigerant circuit including a high-efficiency rotary or scroll compressor. Simplified refrigerant circuits provide easy maintenance, higher accuracy and excellent performance. Also standard are a reversing valve (4-way valve), water-to-refrigerant coaxial (tube-in-tube) coil, TXV (thermostatic expansion valve), and enhanced aluminum fin/rifled copper tube air-to-refrigerant heat exchanger coil.

**AHRI/ISO** — Aquazone units have AHRI/ISO, NRTL (Nationally Recognized Testing Lab), or CSA (Canadian Standards Association) labels and are factory tested under normal operating conditions at nominal water flow rates. Quality assurance is provided via testing report cards shipped with each unit to indicate specific unit performance under cooling and heating modes. Water source heat pumps are New York City MEA (Materials Equipment and Acceptance) 60-00-E rated.

## Quiet operation

Fan motor isolation and hermetic compressor springs provide sound isolation, cabinets are fully insulated to reduce noise transmission, low speed blowers are used for quiet operation through reduced outlet air velocities, and air-to-refrigerant coils are designed for lower airflow coil face velocities. A mute package is also available for extremely noise sensitive applications.

## Design flexibility

Airflow configurations for horizontal units are available in four patterns including left or right return, and left, right, or back discharge. Horizontal units are field convertible from left or right discharge to back discharge. Vertical units are available in four airflow patterns including top discharge with front, right or left return. Standard water temperature range between 60 and 95 F offers maximum design flexibility for boiler/tower applications. Water flow rates as low as 1.5 gpm per ton assist with selection from a various range of circulating pumps. Factory-installed options are offered to meet specific design requirements.

## Safe, reliable operation

Standard safety features for the refrigerant circuit include a high-pressure switch, low-pressure sensor to detect refrigerant loss. Equipment safety features include water loop temperature monitoring, voltage protection, water coil freeze protection, and standard electronic condensate overflow shutdown. All safety features are tested and run at the factory to assure proper operation of all components and safety switches.

All components are carefully designed and selected for endurance, durability, and carefree day-to-day operation.

The Aquazone™ unit is shipped to provide internal and external equipment protection. Shipping supports are placed under the blower housing and compressor feet. In addition, horizontal and vertical units are both mounted on oversized pallets with lag bolts for sturdiness and maximum protection during transit.

## Table of contents

	Page
Features/Benefits . . . . .	1-4
Model Number Nomenclature . . . . .	5
AHRI/ISO Capacity Ratings . . . . .	5
Physical Data . . . . .	6
Options and Accessories . . . . .	6-9
Dimensions . . . . .	10,11
Selection Procedure . . . . .	12,13
Performance Data . . . . .	14-27
Electrical Data . . . . .	28
Typical Piping and Wiring . . . . .	29
Typical Control Wiring Schematics . . . . .	30-36
Application Data . . . . .	37-41
Controls . . . . .	42-45
Guide Specifications . . . . .	46-50

## Ease of installation

The Aquazone unit is packaged for simple low cost handling and requires minimal installation. All units are pre-wired and factory charged with refrigerant. Horizontal units include factory-installed hanger isolation brackets. Vertical units have an internally trapped condensate drain to reduce labor associated with installing an external trap for each unit. Water connections (FPT) and condensate drains (FPT) are anchored securely to the unit cabinet.

## Simple maintenance and serviceability

The Aquazone WSHP units are constructed to provide easy maintenance. All units allow easy access to the compressor section from 3 sides with large removable panels. Additional panels allow access to the blower and control box sections.

The blower housing assembly can be serviced without disconnecting ductwork from the dedicated blower access panel. Blower units come with permanently lubricated bearings for worry-free performance. Blower inlet rings allow blower wheel removal without having to remove the housing or ductwork connections.

Electrical disconnection of the blower motor and control box is easily accomplished via quick disconnects on each component.

Easy removal of the control box from the unit provides access to all refrigeration components.

The refrigeration circuit is easily tested and serviced through high and low pressure ports integral to the refrigeration circuit.

## Maximum control flexibility

Aquazone water source heat pumps provide reliable control operation using a standard microprocessor board with flexible alternatives for many direct digital controls (DDC) applications including the Carrier Comfort Network<sup>®</sup> (CCN) controls and open protocol systems.

Carrier's Aquazone standard unit solid-state control system, the Complete C, provides control of the unit compressor, reversing valve, fan, safety features, and troubleshooting fault indication features. The Complete C control is one of the most user friendly,

low cost, and advanced control boards found in the WSHP industry. Many features are field selectable to provide the ultimate in field installation flexibility. The overall features of this standard control system include:

**50-va transformer** assists in accommodating accessory loads.

**Anti-short cycle timer** provides a minimum off time to prevent the unit from short cycling. The 5-minute timer energizes when the compressor is deenergized, resulting in a 5-minute delay before the unit can be restarted.

**Random start relay** ensures a random delay in energizing each different WSHP unit. This option minimizes peak electrical demand during start-up from different operating modes or after building power outages.

**High and low pressure refrigerant protection** safeguards against unreliable unit operation and prevents refrigerant from leaking.

**Condensate overflow sensor** is an electronic sensor mounted to the drain pan. When condensate pan liquid reaches an unacceptable level, the unit is automatically deactivated and placed in a lockout condition. The sensor recognizes 30 continuous seconds of overflow as a fault condition.

**High and low voltage protection** provides safety protection from excessive or low voltage conditions.

**Automatic intelligent reset** will automatically restart unit 5 minutes after shutdown if the fault has cleared. Should a fault occur 3 times sequentially, lockout will occur.

**Accessory output (24-v)** is provided to cycle a motorized water valve or damper actuator with compressor in applications such as variable speed pumping arrangements.

**Performance monitor (PM)** is a unique feature that monitors water temperatures to warn when the heat pump is operating inefficiently or beyond typical operating range. Field selectable switch initiates a warning code on the unit display.

**Water coil freeze protection (selectable for water or antifreeze)** provides a field selectable switch for water and water/glycol solution systems which initiates a fault when temperatures exceed the selected limit for 30 continuous seconds.

**Air coil freeze protection (check filter operation)** provides a field selectable switch for assessing excessive filter pressure drop. The switch initiates a fault when temperatures exceed the selected limit for 30 continuous seconds.

**Alarm relay setting** is a selectable 24-v or pilot duty dry contact for activating a remote alarm.

**Electric heat option** is an output provided on the controller for operating two stages of emergency electric heat.

**Service Test mode with diagnostic LED (light-emitting diode)** allows service personnel to check the operation of the WSHP and control system efficiently. Upon entering Test mode, time delays speed up, and the Status LED flashes a code to indicate the last fault experienced. This mode provides easy fault diagnosis; based on the fault code that the status LED flashes, Carrier troubleshooting tables provide easy reference to typical problems.

**LED visual output** indicates high pressure, low pressure, low voltage, high voltage, air/water freeze protection, condensate overflow, and control status via a LED panel.

**WSHP Open multiple protocol controller** — Carrier's state of the art water source heat pump multiple protocol controller is capable of communicating BACnet, Modbus and N2 protocols. The controller is designed specifically for Carrier's WSHPs in order to bring more features and benefits to the units such as waterside economizer control, auxiliary heat, dehumidification, etc., in addition to independent compressor and fan operation. The WSHP Open controller can be used to actively monitor and control all modes of operation as well as monitor the following diagnostics and features: unit number, zone temperature, zone set point, zone humidity set point, discharge air temperatures, fan status, stages of heating, stages of cooling, outdoor-air temperature, leaving-air temperature, leaving water temperature, alarm status, and alarm lockout condition.

# Features/Benefits (cont)



The controller also provides a proactive approach to maintenance and service enabling the unit to recognize and correct operating conditions outside of recommended operating conditions avoiding the need to manually restart equipment. From a system standpoint WSHP Open controller can accept both water and airside linkage.

Condenser water linkage provides optimized water loop operation using the UC (universal controller) Open XP loop controller. Loop pump operation is automatically controlled by WSHP equipment occupancy schedules, unoccupied demand and tenant override conditions. Positive pump status feedback prevents nuisance fault trips.

Airside linkage enables the WSHP equipment to be completely integrated with the Carrier's VVT® application as a system. The WSHP Open controller responds to individual zone demands rather than average temperature conditions to provide individual temperature control in each zone.

This controller has a 38.4 kilobaud communications capability and is compatible with i-Vu® Open building automation system controls and CCN controls. The addition of the Carrier CO<sub>2</sub> sensor in the conditioned space provides ASHRAE 62-99 compliance and demand controlled ventilation (DCV). A DCV control strategy is especially beneficial for a water source heat pump system to minimize the energy utilized to condition ventilation air. In combination with energy efficient Aquazone units, DCV may be the most energy efficient approach ever developed for a water source heat pump system.

The WSHP Open multiple protocol controller is designed specifically for constant volume (CV) and variable volume and temperature (VVT®) applications. This comprehensive controls system allows water source heat pumps

to be linked together to create a fully functional HVAC (heating, ventilation, and air conditioning) automation system.

## **PremierLink™ controller adds reliability, efficiency, and simplification**

The PremierLink direct digital controller can be ordered as a factory-installed option. Designed and manufactured exclusively by Carrier, the controller can be used to actively monitor and control all modes of operation as well as monitor the following diagnostics and features: unit number, zone temperature, zone set point, zone humidity set point, discharge air temperatures, fan status, stages of heating, stages of cooling, outdoor-air temperature, leaving-air temperature, leaving water temperature, alarm status, and alarm lock-out condition.

This controller has a 38.4 kilobaud communications capability and is compatible with i-Vu Open building automation system controls and CCN controls. The addition of the Carrier CO<sub>2</sub> sensor in the conditioned space provides ASHRAE 62-99 compliance and demand controlled ventilation (DCV). A DCV control strategy is especially beneficial for a water source heat pump system to minimize the energy utilized to condition ventilation air. In combination with energy efficient Aquazone units, DCV may be the most energy efficient approach ever developed for a water source heat pump system.

The PremierLink peer-to-peer, Internet ready communicating control is designed specifically for constant volume (CV) and variable volume and temperature (VVT®) applications. This comprehensive controls system allows water source heat pumps to be linked together to create a fully functional

HVAC (heating, ventilation, and air conditioning) automation system.

## **Open protocol for diverse control**

— The LON controller option is ideal when building automation requires interoperability across diverse control platforms. This LONMark\*\* compliant offering can operate as standalone or as a part of Local Operating Network (LON) via the LonWorks\*\* FTT-10 Free Topology communication network. Pre-engineered application specific to Aquazone water source heat pumps and digital wall sensors communicating over Sensor Link (S-Link) communication protocol completes a system of networked control.

**Humidity control** — Aquazone 50PCH,PCV units provide very good latent capacity and are an excellent choice for controlling humidity within a zone in many applications. The latent capacity of the units can be increased based on zone conditions with the use of fan speed control and a humidistat. The Deluxe D controls option provides fan speed control based on relative humidity and is an effective, low-cost means of controlling humidity.

## **Puron® refrigerant (R-410A)**

Puron refrigerant (R-410A) is a non-chlorine based refrigerant. Puron refrigerant characteristics, compared to R-22, have:

- Binary and near azeotropic mixture of 50% R-32 and 50% R-125.
- Higher efficiencies (50 to 60% higher operating pressures).
- Non-ozone depleting potential and low global warming potential.
- Virtually no glide. Unlike other alternative refrigerants, the two components in Puron refrigerant have virtually the same leak rates. Therefore, refrigerant can be added if necessary without recovering the charge.

\* Sponsored by ASHRAE (American Society of Heating, Refrigerating and Air Conditioning Engineers).

† Registered trademark of Schneider Electric.

\*\* Registered trademark of Echelon Corporation.

# Model number nomenclature



## 50PCH,PCV

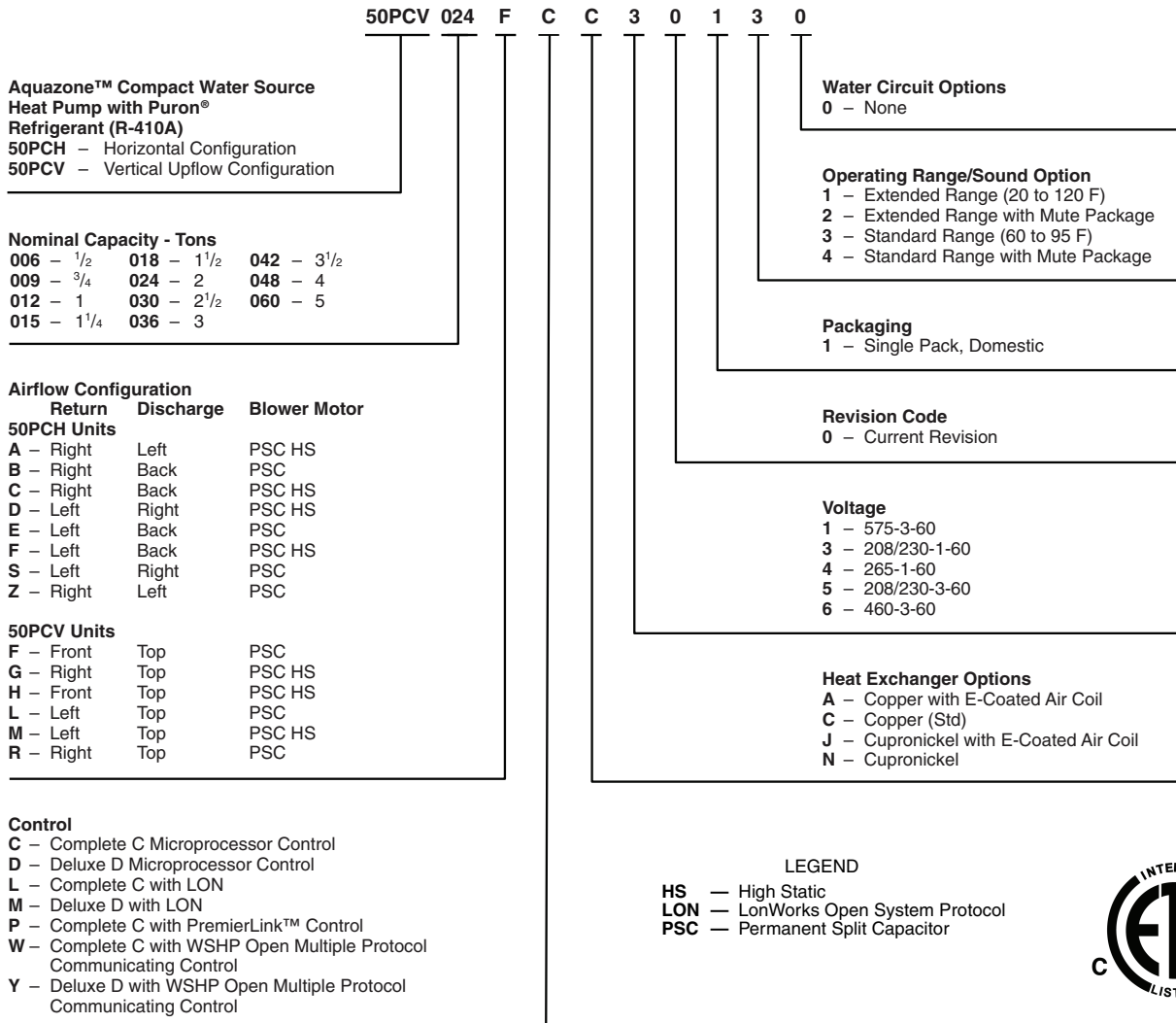

**LEGEND**  
 HS — High Static  
 LON — LonWorks Open System Protocol  
 PSC — Permanent Split Capacitor



# AHRI/ISO capacity ratings

50PCH, PCV UNIT SIZE	WATER LOOP HEAT PUMP				GROUND WATER HEAT PUMP				GROUND LOOP HEAT PUMP			
	COOLING 86 F		HEATING 68 F		COOLING 59 F		HEATING 50 F		COOLING 77 F		HEATING 32 F	
	CAPACITY (Btuh)	EER (Btuh/W)	CAPACITY (Btuh)	COP	CAPACITY (Btuh)	EER (Btuh/W)	CAPACITY (Btuh)	COP	CAPACITY (Btuh)	EER (Btuh/W)	CAPACITY (Btuh)	COP
006	5,800	13.2	7,500	4.7	6,900	21.1	6,200	4.0	6,200	15.4	4,900	3.4
009	8,800	13.4	11,600	4.2	10,100	21.0	9,800	3.9	9,300	15.7	7,900	3.4
012	11,700	13.5	15,200	4.3	13,700	20.8	12,500	3.8	12,000	14.9	9,900	3.2
015	14,500	15.4	17,300	5.0	16,800	24.5	14,400	4.4	15,000	17.2	11,100	3.6
018	17,300	14.3	21,500	5.0	20,600	24.2	17,200	4.4	18,400	16.3	13,900	3.4
024	23,700	13.4	28,500	4.7	26,700	20.9	24,000	4.1	24,900	15.4	18,500	3.3
030	28,100	13.4	35,100	4.6	31,700	20.1	29,600	4.1	28,900	15.1	23,400	3.4
036	34,500	13.5	45,200	4.4	38,700	20.7	37,500	4.0	35,300	14.9	29,600	3.3
042	40,100	13.1	52,700	4.3	45,900	19.6	44,000	3.8	40,500	14.4	34,300	3.2
048	47,700	13.3	55,900	4.7	54,300	20.5	46,500	4.1	49,000	14.7	36,400	3.4
060	59,400	13.4	77,000	4.3	66,600	19.9	64,000	3.8	60,100	14.8	50,500	3.1

**LEGEND**  
 COP — Coefficient Performance  
 EER — Energy Efficiency Ratio



**NOTES:**  
 1. Cooling capacities based on 80.6 F db (dry bulb), 66.2 F wb (wet bulb) entering air temperature.  
 2. Heating capacities based on 68 F db, 59 F wb entering air temperature.  
 3. All ratings based on operation at lower voltage of dual voltage rated models.

# Physical data



## PHYSICAL DATA — 50PCH,PCV UNITS

50PCH,PCV UNIT	006	009	012	015	018	024	030	036	042	048	060
COMPRESSOR (1 each)	Rotary					Scroll					
REFRIGERANT TYPE	R-410A										
Factory Charge (oz)	17	18.5	23	32	43	43	47	50	70	74	82
FAN MOTOR AND BLOWER	PSC/3										
Fan Motor Type/Speeds											
Fan Motor (hp)											
Blower Wheel Size (Dia x W) (in.)	1/25 5 x 5	1/10 6 x 5	1/10 6 x 5	1/6 8 x 7	1/6 8 x 7	1/4 9 x 7	3/4 9 x 7	1/2 9 x 8	3/4 9 x 8	3/4 10 x 10	1 11 x 10
COAX VOLUME (gal.)	0.123	0.143	0.167	0.286	0.450	0.286	0.323	0.323	0.890	0.738	0.939
WATER CONNECTION SIZE IPT (in.)	1/2					3/4				1	
HORIZONTAL											
Air Coil Dimensions (H x W)(in.)	10 x 15			16 x 22				20 x 25		20 x 35	
Standard Filter - (Qty)	(1) 10 x 18			(1) 16 x 25		(1) 18 x 25		(1) 20 x 28 or (2) 20 x 14		(1) 20 x 24, (1) 20 x 14	
1 in. Throwaway											
Weight (lb)											
Operating	103	105	114	153	158	174	182	203	218	263	278
Packaged	113	115	124	158	163	179	187	209	224	270	285
Corner Weight (lb)*											
Left-Front	37	38	42	53	55	62	67	75	81	98	103
Right-Front	24	24	26	36	37	40	41	47	50	60	64
Left-Back	23	23	25	34	35	39	40	44	48	58	61
Right-Back	19	20	21	30	31	33	34	37	39	47	75
VERTICAL											
Air Coil Dimensions (H x W)(in.)	10 x 15			20 x 17.25				24 x 17.75		24 x 28.25	
Standard Filter - (Qty)	(1) 10 x 18			(1) 20 x 20		(1) 24 x 24		(1) 24 x 24		(1) 14 x 24, (1) 18 x 24	
1 in. Throwaway											
Weight (lb)											
Operating	103	105	114	153	158	189	197	203	218	263	278
Packaged	113	115	124	158	163	194	202	209	224	270	285

### LEGEND

FPT — Female Pipe Thread  
PSC — Permanent Split Capacitor

\*Front is located at control box end.

NOTE: All units have grommet compressor mountings, and 1/2-in. and 3/4-in. electrical knockouts.

## Options and accessories

ITEM	FACTORY-INSTALLED OPTION	FIELD-INSTALLED ACCESSORY
Aquazone™ System Control Panel		X
Aquazone Thermostats		X
Ball Valves		X
Cupronickel Heat Exchangers	X	
Deluxe D Control System	X	
E-Coated Airside Coil	X	
Extended Range Units	X	
Filter Rack		X
Full Filter Frame		X
Fire-Rated Hoses		X
High-Static Blower (available on sizes 015-060)	X	
Hose Kit Assemblies		X
LONMark Compliant Controller	X	
UC Open XP Loop Controller		X
PremierLink™ Controller	X	
PremierLink Accessories		X
Remote Sensors (SPT, CO <sub>2</sub> , Humidity Sensors)		X
Solenoid Valves		X
Sound Attenuation (Mute) Package	X	
Y Strainers		X
WSHP Open Multiple Protocol Controller	X	

# Options and accessories (cont)



## Factory-installed options

**Cupronickel heat exchangers** are available for higher corrosion protection for applications such as open tower, geothermal, etc. Consult the water quality guidelines for proper application and selection of this option.

**Deluxe D control system** provides the same functions as the Complete C control system while incorporating additional flexibility and functions including:

Thermostat input capabilities accommodate emergency shutdown mode and night setback (NSB) with override potential. Night setback from low temperature thermostat with 2-hour override is initiated by a momentary signal from the thermostat.

Compressor relay staging is used with dual stage units (units with 2 compressors and 2 Deluxe D controls) or in master/slave applications.

Boilerless electric heat control system allows automatic changeover to electric heat at low loop water temperature.

Intelligent reversing valve operation minimizes reversing valve operation for extended life and quiet operation.

Thermostat type select (Y, O or Y, W) provides the ability to work and select heat pump or heat/cool thermostats (Y, W).

Reversing valve signal select (O or B) provides the selection for heat pump O/B thermostats.

Dehumidistat input provides fan control for dehumidification operation.

Multiple units on one thermostat/wall sensor provides communication for up to three heat pumps on one thermostat.

Boilerless changeover temperature provides the selection of boilerless changeover temperature set point.

Accessory relays allow configuration for multiple applications including fan and compressor cycling, digital night setback (NSB), mechanical night setback, water valve operation, and outside air damper operation.

**E-coated airside coil** is available for highly corrosive environments. This is an excellent option for coastal areas, marine applications or other areas in which corrosion may be an issue.

**Extended range units** insulate the coaxial coil to prevent condensation, and therefore potential dripping problems, in applications where the entering water temperature is below the normal operating range (less than 60 F). Units are capable of operating at a range of 20 to 120 F.

**High-static blower** increases airflow at various static pressure conditions, providing even more flexibility to the high blower performance offered by the standard models. High-static blower is available on unit sizes 015-060.

**WSHP Open multiple protocol controller** is a proactive controller capable of communicating BACnet, Modbus and N2 protocols. The controller is designed to allow users the access and ability to change and configure multiple settings and features including indoor air quality (IAQ), water-side economizer controls, etc.

**LONMark compliant controller** contains the factory-loaded Aquazone water source heat pump application for an interoperable control solution.

**PremierLink™ controller** is compatible with the Carrier Comfort Network® (CCN) and other building automation systems (BAS). This control allows users the access and ability to change factory-defined settings, thus expanding the function of the standard unit.

**Sound attenuation package (mute package)** is available for applications that require especially low noise levels. With this option, a double application of sound attenuating material is applied to the internal divider, side panels, top and bottom panels. Sound attenuating material is also added to the fan housing. Spring isolation is added to the compressor mounting. The mute package in combination with standard unit noise reduction features (i.e., as mentioned previously) provide sound levels and noise reduction to the highest degree.

## Field-installed accessories

**Aquazone™ system control panel** includes a preprogrammed, easy to use, Carrier Comfort Controller set up for a WSHP system.

- Panel coordinates and monitors loop water temperature and all water side ancillary equipment.
- The 50RLP model nomenclature is used to customize the control panel options to control all WSHP system requirements.
- Panel can be ordered to include 2, 4, 6, or 8 stages of system heat rejection.
- Panel can be ordered to include 2, 4, 6, or 8 stages of system heat addition.
- Panel can be ordered with unique WSHP zone operation capabilities for stand-alone systems (i.e., noncommunicating) to control 10 or 18 zones of WSHP units.
- Panel can be ordered to control variable frequency cooling tower fan operation.
- System pumping operation can be configured for start/stop, lead/lag, or variable frequency pump operation.
- Direct Digital Controls (DDC) compatible using the Carrier Comfort Network® (CCN) and WSHP units utilizing PremierLink™ CCN controllers.

**Aquazone thermostats** are both attractive and multi-functional, accommodating stand-alone water source heat pump installations.

Programmable 7-day thermostat offers 2-stage heat, 2-stage cool, auto changeover, copy command, 4 settings per day, fully electronic, 24 vac, backlit LCD, keypad lock-out, no batteries required, 5-minute compressor protection, NEVERLOST™ memory, 3 security levels, and temperature display in degrees F or C.

Programmable 7-day light-activated thermostat offers the same features as the 7-day programmable thermostat and also includes occupied comfort settings with lights on and unoccupied energy savings with lights off.

Programmable 7-day flush-mount thermostat offers same features as the 7-day programmable thermostat including locking coverplate with tamper proof screws, flush to wall mount, holiday/vacation programming, set point limiting, dual point with adjustable deadband, O or B terminal, and optional wall or duct-mounted remote sensor.

# Options and accessories (cont)



Programmable 5-day thermostat offers 2-stage heat, 2-stage cool, auto changeover, 5-minute built-in compressor protection, locking cover, temperature display in degrees F or C, keypad lockout, backlit display, 5-1-1 programming, O or B terminal, dual set point with adjustable deadband, configurable display, self-prompting program, and 4 settings per day.

Non-programmable thermostat offers 2 heat stages, 2 cool stages, auto changeover, 5-minute built in compressor protection, locking cover, temperature display in degrees F or C, keypad lockout, large display, backlit display, O or B terminal, dual set point with adjustable deadband, and a backplate with terminals.

**Ball valves (brass body)** used for shutoff and balancing water flow. The valves are available with memory, memory stop, and pressure temperature ports. The valves are UL-listed brass body, ball and stem type with Teflon\* seats and seals and are available in five sizes (1/2, 3/4, 1, 1 1/4, 1 1/2 in.).

**Filter rack (2 in.)** is available in place of the standard 1-in. return air filter to enhance the filtration system of the water source heat pump. The 2-in. filter rack does not include filters.

**Fire-rated hoses** are 2 ft long and have a fixed MPT on one end and a swivel with an adapter on the other end. Hose kits have both a supply and return hose and are stainless steel or galvanized. Five sizes are available (1/2, 3/4, 1, 1 1/4, 1 1/2 in.).

**Full filter frame** is available in place of the standard 1 in. return air filter. The frame includes a locking door to facilitate filter changes and cleaning without disrupting duct connections. Frames are available in 1 and 2 in. sizes.

**Hose kit assemblies** provide all the necessary components to hook up a water-side system. Supply hose includes a ported ball valve with pressure/temperature (P/T) plug ports, flexible stainless steel hose with swivel and nipple. Return hose includes a ball valve, preset automatic balancing valve (gpm) with two P/T ports, flexible stainless steel hose with a swivel and nipple, balancing valve, and low-pressure drop water control valve.

**UC Open XP loop controller** with six stages (2 stages for heating and 4 stages for heat rejection):

- Loop temperature alarms

- Two pump single loop flow monitoring with the ability to manually select the lead pump
- Loop water temperature sensor test circuit
- Functional test simulation from operator keypad
- Real timeclock, industrial noise ratings
- Loop water temperature control switch

**PremierLink™ accessories** provide a fully integrated WSHP DDC system. Accessories include supply air temperature sensors (with override and/or set point adjustment), communicating room sensors, CO<sub>2</sub> sensors (for use in demand controlled ventilation), and linkage thermostats (to control multiple units from one thermostat).

**Remote sensors** are available for Aquazone flush-mount thermostats and for wall (wired and wireless) or duct mounted applications.

SPT Standard offers space temperature sensor with communication port.

SPT Plus offers space temperature sensor with set point adjust, local override with indicating light and communication port.

SPT Pro offers space temperature sensor with LCD display, set point adjust, local override, alarm icon, outside air, and unit status with heating and cooling set points.

SPT Pro+ offers space temperature sensor with LCD display, set point adjust, local override, alarm icon, outside air, unit status with heating and cooling set points, and fan speed control.

LON wall sensors are available in 3 models: sensor only, sensor with status override indicator, and sensor with set point, status adjustment override, and digital LCD display.

**Solenoid valves (brass body)** offer 6.5 watt coil, 24 volt, 50/60 Hz, and 7.5-va with slow operation for quiet system application. Three sizes are available (1/2, 3/4, 1 in.).

**Y strainers (bronze body)** are “Y” type strainers with a brass cap and a stainless steel strainer screen. Maximum operating pressure rating of strainers is 400 psi. Strainers are available with blow down valves. Six sizes are available (1/2, 3/4, 1, 1 1/4, 1 1/2, 2 in.).

\*Teflon is a trademark of E. I. du Pont de Nemours and Company.



**AQUAZONE™ THERMOSTATS**

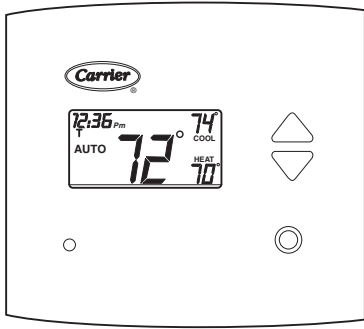

**7-DAY PROGRAMMABLE/  
LIGHT-ACTIVATED PROGRAMMABLE**

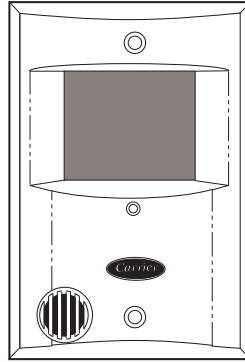

**7-DAY PROGRAMMABLE  
FLUSH MOUNT**

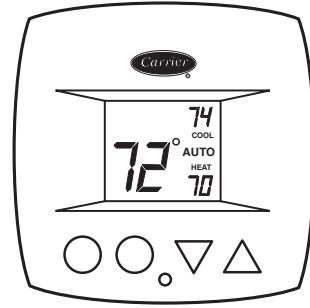

**5-DAY PROGRAMMABLE/  
NON-PROGRAMMABLE**

**WSHP OPEN SENSORS**

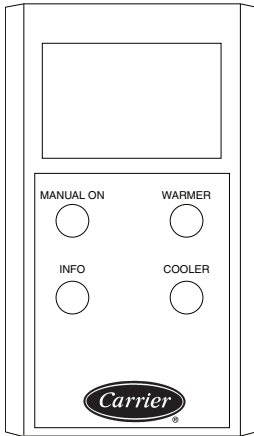

**SPACE TEMPERATURE  
SENSOR WITH SET  
POINT ADJUSTMENT  
AND LOCAL OVERRIDE**

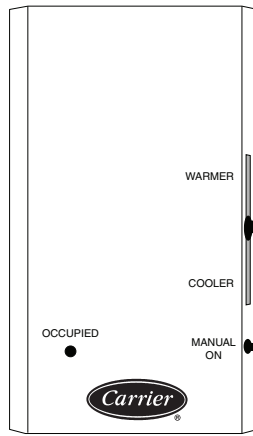

**SPACE TEMPERATURE  
SENSOR WITH SLIDE SET  
POINT ADJUSTMENT AND  
LOCAL OVERRIDE**

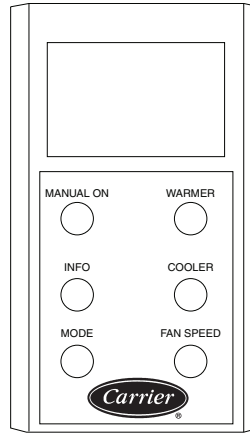

**SPACE TEMPERATURE  
SENSOR WITH SET  
POINT ADJUSTMENT,  
FAN SPEED CONTROL,  
AND LOCAL OVERRIDE**

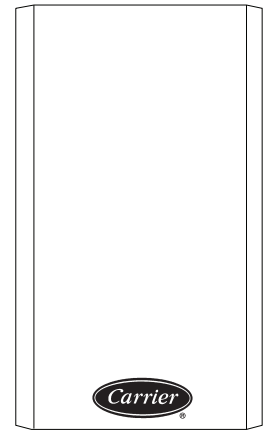

**SPACE TEMPERATURE  
SENSOR ONLY**

**LON WALL SENSORS**

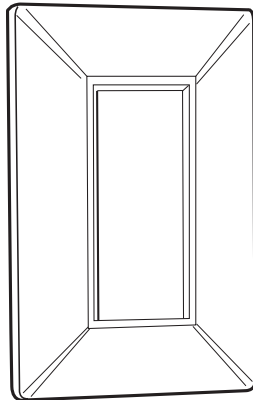

**SENSOR ONLY**

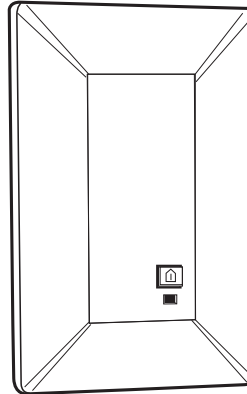

**SENSOR WITH OVERRIDE**

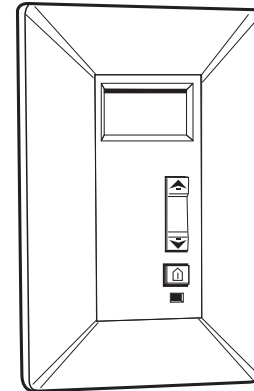

**SENSOR WITH SET POINT ADJUSTMENT,  
OVERRIDE AND DIGITAL LCD**

## 50PCH UNIT

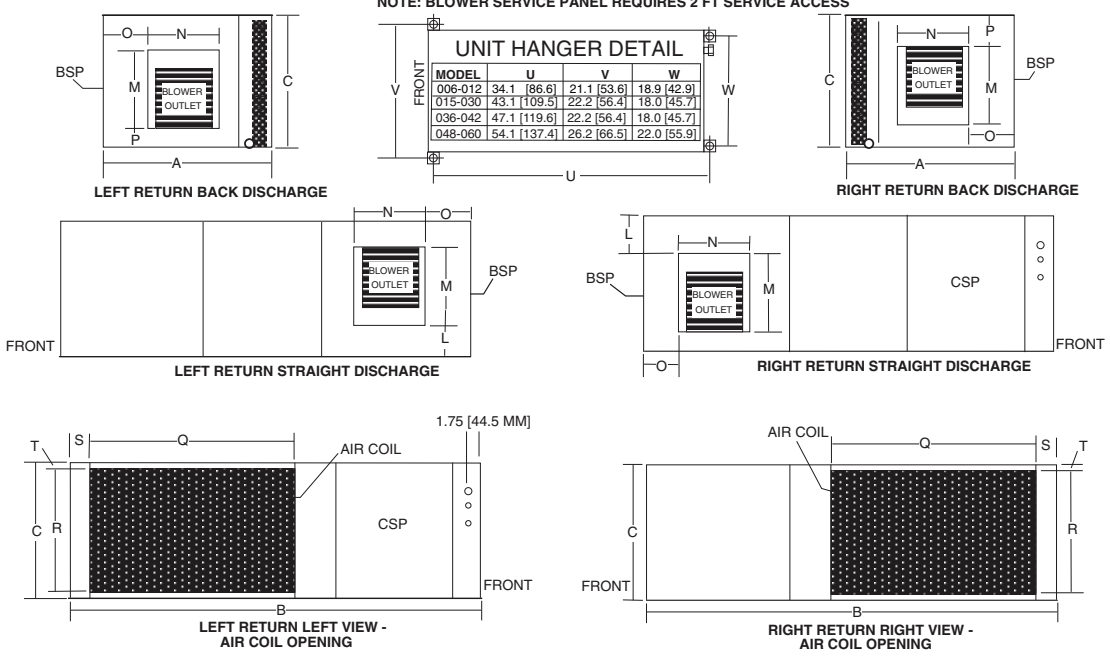
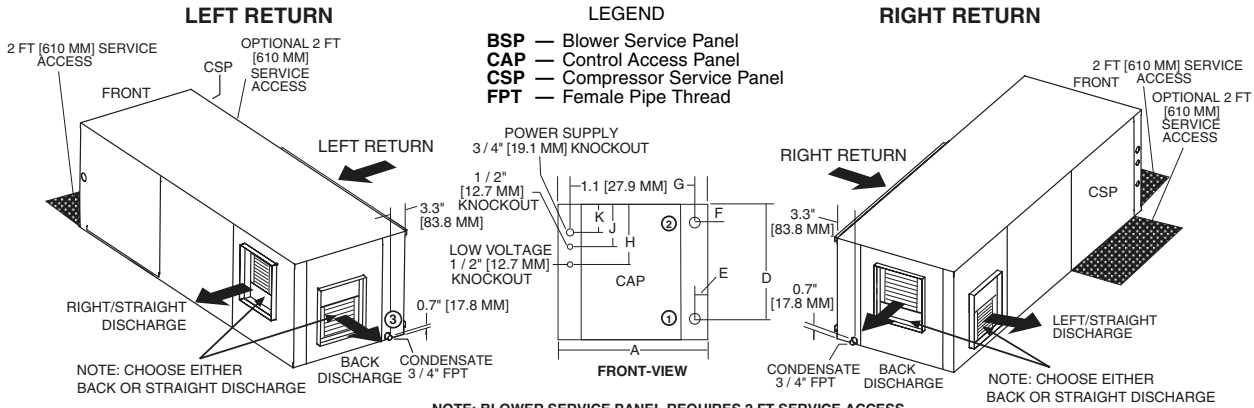

## 50PCH006-060 UNITS

50PCH UNIT SIZE	OVERALL CABINET			WATER CONNECTIONS				Size (IPT)	ELECTRICAL KNOCKOUTS			DISCHARGE CONNECTIONS DUCT FLANGE (± 0.10 in., ± 2.5 mm)				RETURN CONNECTION USING RETURN AIR OPENING				
	A Width	B Depth	C Height	1	2	3	4		H	J	K	L	M Supply Height	N Supply Width	O	P	Q Return Depth	R Return Height	S	T
				Loop In	Loop Out	Low Voltage	Low Voltage		Power Supply	D	E									
<b>006-012</b>	in. 19.1 cm 48.5	in. 34.1 cm 86.6	in. 11.1 cm 28.2	9.6 24.3	1.1 2.7	1.5 3.8	1.1 2.7	1/2 1.3	8.1 20.6	5.1 13.0	2.1 5.4	0.8 1.9	8.9 22.7	6.7 17.0	8.2 13.3	1.3 3.3	16.1 41.0	9.8 25.0	1.1 2.7	0.6 1.5
<b>015</b>	in. 20.1 cm 51.1	in. 43.1 cm 109.5	in. 17.0 cm 43.2	15.1 38.4	1.4 3.4	3.2 8.1	1.4 3.5	1/2 1.3	12.1 30.8	9.1 23.2	6.1 15.6	2.6 6.6	13.3 33.8	9.9 25.1	4.1 10.5	1.3 3.3	23.0 58.4	15.0 38.1	1.1 2.8	1.0 2.5
<b>018</b>	in. 20.1 cm 51.1	in. 43.1 cm 109.5	in. 17.0 cm 43.2	15.1 38.4	1.4 3.4	4.1 10.4	1.4 3.5	1/2 1.3	12.1 30.8	9.1 23.2	6.1 15.6	2.6 6.6	13.3 33.8	9.9 25.1	4.1 10.5	1.3 3.3	23.0 58.4	15.0 38.1	1.1 2.8	1.0 2.5
<b>024</b>	in. 20.1 cm 51.1	in. 43.1 cm 109.5	in. 18.3 cm 46.5	15.1 38.4	1.4 3.4	4.4 11.3	1.4 3.5	3/4 1.9	12.1 30.8	9.1 23.2	6.1 15.6	2.6 6.6	13.3 33.8	9.9 25.1	4.1 10.5	1.3 3.3	23.0 58.4	16.3 41.4	1.1 2.8	1.0 2.5
<b>030</b>	in. 20.1 cm 51.1	in. 43.1 cm 109.5	in. 18.3 cm 46.5	15.1 38.4	1.4 3.4	3.1 7.8	1.4 3.5	3/4 1.9	12.1 30.8	9.1 23.2	6.1 15.6	2.6 6.6	13.3 33.8	9.9 25.1	4.1 10.5	1.3 3.3	23.0 58.4	16.3 41.4	1.1 2.8	1.0 2.5
<b>036</b>	in. 20.1 cm 51.1	in. 47.1 cm 119.6	in. 21.0 cm 53.3	15.1 38.4	1.4 3.4	5.3 13.4	1.4 3.5	3/4 1.9	16.1 41.0	13.1 33.3	10.1 25.7	2.5 6.3	16.1 40.9	11.0 27.9	3.0 7.7	2.5 6.4	25.9 65.8	19.0 48.3	1.1 2.8	1.0 2.5
<b>042</b>	in. 20.1 cm 51.1	in. 47.1 cm 119.6	in. 21.0 cm 53.3	15.1 38.4	1.4 3.4	4.4 11.3	1.4 3.5	3/4 1.9	16.1 41.0	13.1 33.3	10.1 25.7	2.5 6.3	16.1 40.9	11.0 27.9	3.0 7.7	2.5 6.4	25.9 65.8	19.0 48.3	1.1 2.8	1.0 2.5
<b>048</b>	in. 24.1 cm 61.2	in. 54.1 cm 137.4	in. 21.0 cm 53.3	15.1 38.4	1.4 3.4	4.4 11.1	1.4 3.5	1	16.1 41.0	13.1 33.3	10.1 25.7	3.7 9.5	16.1 41.0	13.7 34.8	4.1 10.3	1.3 3.2	35.9 91.2	19.0 48.3	1.1 2.8	1.0 2.5
<b>060</b>	in. 24.1 cm 61.2	in. 54.1 cm 137.4	in. 21.0 cm 53.3	15.1 38.4	1.4 3.4	3.8 9.7	1.4 3.5	1	16.1 41.0	13.1 33.3	10.1 25.7	1.7 4.4	18.1 46.0	13.7 34.8	4.1 10.3	1.3 3.2	35.9 91.2	19.0 48.3	1.1 2.8	1.0 2.5

- NOTES:**
- While clear access to all removable panels is not required, installer should take care to comply with all building codes and allow adequate clearance for future field service.
  - Horizontal units shipped with filter bracket only. This bracket should be removed for return duct connection.
  - Discharge flange and hanger brackets are factory installed.
  - Condensate is 3/4-in. (19.1 mm) FPT copper.
  - Blower service panel requires 2 ft (610 mm) service access.
  - Blower service access is through back panel on left or right discharge units or through panel opposite air coil on back discharge units.

### 50PCV UNIT

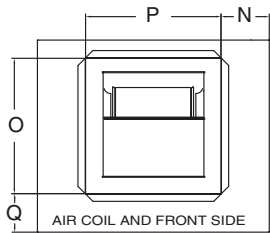

TOP VIEW-FRONT RETURN

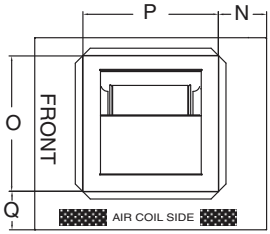

TOP VIEW-RIGHT RETURN

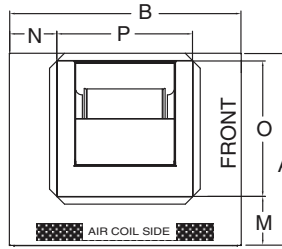

TOP VIEW-LEFT RETURN

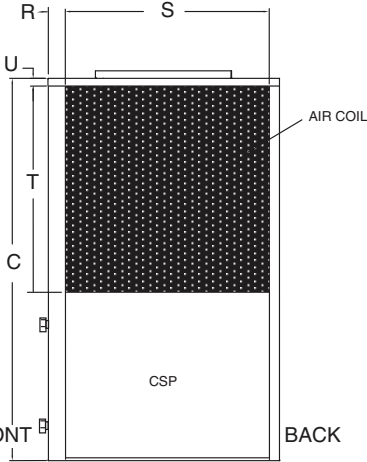

RIGHT RETURN RIGHT VIEW  
- AIR COIL OPENING

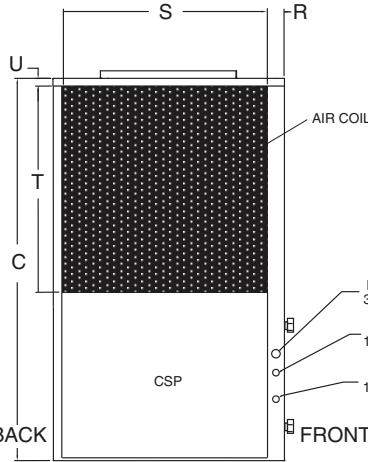

LEFT RETURN LEFT VIEW  
- AIR COIL OPENING

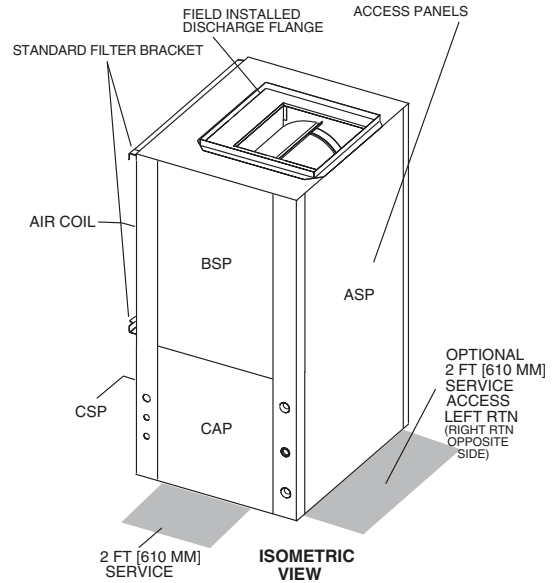

ISOMETRIC VIEW

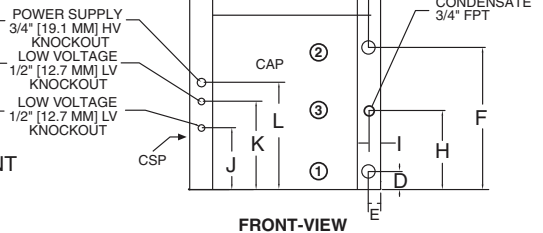

FRONT-VIEW

- LEGEND**
- ASP — Alternate Service Panel
  - BSP — Blower Service Panel
  - CAP — Control Access Panel
  - CSP — Compressor Service Panel
  - FPT — Female Pipe Thread
  - HV — High Voltage
  - LV — Low Voltage

### 50PCV006-060 UNITS

50PCV UNIT SIZE	OVERALL CABINET			WATER CONNECTIONS						ELECTRICAL KNOCKOUTS			DISCHARGE CONNECTION DUCT FLANGE INSTALLED (±0.10 in., ±2.5 mm)					RETURN CONNECTION USING RETURN AIR OPENING				
	A Width	B Depth	C Height	1		2		3		J 1/2-in. (1.3 cm) Low Voltage	K 1/2-in. (1.3 cm) Low Voltage	L 3/4-in. (1.3 cm) Power Supply	M	N	O Supply Width	P Supply Depth	Q	R	S Return Depth	T Return Height	U	
				D	E	F	G	H	I													Size (IPT)
	Loop In		Loop Out																			
006-012	in. 19.1	in. 19.1	in. 22.0	1.4	1.6	9.5	1.6	6.1	1.6	1/2	2.9	5.9	8.9	8.9	5.1	9.0	9.0	5.5	2.1	16.2	9.9	0.7
	cm 48.5	cm 48.5	cm 55.9	3.6	4.1	24.1	4.3	15.6	4.1	1.3	7.3	14.9	22.5	22.7	12.9	22.9	22.9	14.0	5.3	41.1	25.1	1.9
015	in. 21.5	in. 21.5	in. 39.0	1.9	1.4	13.8	1.4	8.1	1.4	1/2	4.1	7.1	10.1	6.4	3.8	14.0	14.0	5.3	2.3	18.3	20.9	0.7
	cm 54.6	cm 54.6	cm 99.1	4.8	3.6	35.1	3.6	20.6	3.6	1.3	10.5	18.1	25.7	16.1	9.5	35.6	35.6	13.6	5.8	46.5	53.1	1.9
018	in. 21.5	in. 21.5	in. 39.0	1.9	1.4	12.9	1.4	8.1	1.4	1/2	4.1	7.1	10.1	6.4	3.8	14.0	14.0	5.3	2.3	18.3	20.9	0.7
	cm 54.6	cm 54.6	cm 99.1	4.8	3.6	32.8	3.6	20.6	3.6	1.3	10.5	18.1	25.7	16.1	9.5	35.6	35.6	13.6	5.8	46.5	53.1	1.9
024	in. 21.5	in. 21.5	in. 40.0	1.9	1.4	13.8	1.4	8.1	1.4	3/4	4.1	7.1	10.1	6.4	3.8	14.0	14.0	5.3	2.3	18.3	20.9	0.7
	cm 54.6	cm 54.6	cm 101.6	4.8	3.6	35.1	3.6	20.6	3.6	1.9	10.5	18.1	25.7	16.1	9.5	35.6	35.6	13.6	5.8	46.5	53.1	1.9
030	in. 21.5	in. 21.5	in. 40.0	1.9	1.4	15.2	1.4	8.1	1.4	3/4	4.1	7.1	10.1	6.4	3.8	14.0	14.0	5.3	2.3	18.3	20.9	0.7
	cm 54.6	cm 54.6	cm 101.6	4.8	3.6	38.6	3.6	20.6	3.6	1.9	10.5	18.1	25.7	16.1	9.5	35.6	35.6	13.6	5.8	46.5	53.1	1.9
036	in. 21.5	in. 26.0	in. 45.0	1.9	1.4	15.7	1.4	8.1	1.4	3/4	4.1	7.1	10.1	6.4	3.8	14.0	14.0	5.1	2.3	22.8	23.9	0.7
	cm 54.6	cm 66.0	cm 114.3	4.8	3.6	39.9	3.6	20.6	3.6	1.9	10.5	18.1	25.7	16.1	9.5	35.6	35.6	13.1	5.8	57.9	60.7	1.9
042	in. 21.5	in. 26.0	in. 45.0	1.9	1.4	16.6	1.4	8.1	1.4	3/4	4.1	7.1	10.1	6.4	3.8	14.0	14.0	5.1	2.3	22.8	23.9	0.7
	cm 54.6	cm 66.0	cm 114.3	4.8	3.6	42.0	3.6	20.6	3.6	1.9	10.5	18.1	25.7	16.1	9.5	35.6	35.6	13.1	5.8	57.9	60.7	1.9
048	in. 24.0	in. 32.5	in. 46.0	1.9	1.4	16.6	1.4	8.1	1.4	1	4.1	7.1	10.1	6.9	7.3	16.0	18.0	5.1	2.3	29.3	22.5	0.7
	cm 61.0	cm 82.6	cm 116.8	4.8	3.6	42.2	3.6	20.6	3.6	2.5	10.5	18.1	25.7	17.4	18.4	40.6	45.7	13.1	5.8	74.4	57.0	1.9
060	in. 24.0	in. 32.5	in. 46.0	1.9	1.4	16.7	1.4	8.1	1.4	1	4.1	7.1	10.1	6.9	7.3	16.0	18.0	5.1	2.3	29.3	22.5	0.7
	cm 61.0	cm 82.6	cm 116.8	4.8	3.6	42.4	3.6	20.6	3.6	2.5	10.5	18.1	25.7	17.4	18.4	40.6	45.7	13.1	5.8	74.4	57.0	1.9

- NOTES:
- Shaded areas are recommended service areas. Installer should take care to comply with all building codes and allow adequate clearance for future field service.
  - Front and side access is preferred for service access. However, all components may be serviced from the front access panel if side access is not available except on 50PCV009-030 with front return.
  - Discharge flange is field installed.
  - Condensate is 3/4 in. (19.1 mm) FPT.
  - Units shipped with filter rails. These rails should be removed for return duct connection.
  - See WSPH Accessory Price Page for accessory air filter frame with duct collar.

# Selection procedure (with 50PCH024 example)



## I Determine the actual cooling and heating loads at the desired dry bulb (db) and wet bulb (wb) conditions.

Given:

Total Cooling (TC) . . . . . 21,100 Btuh  
 Sensible Cooling (SC) . . . . . 16,500 Btuh  
 Entering-Air Temperature db . . . . . 80 F  
 Entering-Air Temperature wb . . . . . 65 F

## II Determine the following design parameters:

Entering water temperature, water flow rate (gpm), airflow (cfm), water flow pressure drop and design wet and dry bulb temperatures. Airflow cfm should be between 300 and 450 cfm per ton. Unit water pressure drop should be kept as close as possible across units to make water balancing easier. Enter the 50PCH024 Performance Data tables and find the proper indicated water flow and water temperature.

For example:

Entering Water Temp . . . . . 90 F  
 Water Flow (Based upon  
 12 F rise in temp) . . . . . 4.5 gpm  
 Airflow cfm . . . . . 850 cfm

## III Select a unit based on total cooling and total sensible cooling conditions.

Enter tables at the design water flow and water temperature. Read the total and sensible cooling capacities.

NOTE: Interpolation is permissible, extrapolation is not.

For example:

Enter the 50PCH024 performance table at design water flow and water temperature. Read total cooling, sensible cooling and heat of rejection capacities:

Total Cooling . . . . . 23,100 Btuh  
 Sensible Cooling . . . . . 17,400 Btuh  
 Heat of Rejection . . . . . 30,100 Btuh

Read the heat capacity. If the heat capacity exceeds the design criteria, it is acceptable.

NOTE: It is quite normal for water source heat pumps to be selected on cooling capacity only since the heating output is usually greater than the cooling capacity.

## IV Determine the correction factors associated with the variable factors of dry bulb and wet bulb using the correction factors tables found in this book.

Using the following formulas to determine the correction factors of dry bulb and wet bulb:

- a) Corrected Total Cooling = tabulated total cooling x wet bulb correction x airflow correction.
- b) Corrected Sensible Cooling = tabulated sensible cooling x wet/dry bulb correction x airflow correction

## V Determine entering air and airflow correction using the correction factors tables found in this book.

The nominal airflow for 50PCH024 is 800 cfm. The design parameter is 850 cfm.

$$850/800 = 106.25\% \text{ of nominal airflow}$$

Use the 106.25% row in the Airflow Correction table.

The entering air temperature wb is 65 F. Use the 65 F row in the Entering Air Correction table.

Using the following formulas to determine the correction factors of entering air and airflow correction:

	Table	Ent Air	Airflow	Corrected
Corrected Total Cooling	=	23,100	x 0.968 x 1.005	= 22,473
Corrected Sensible Cooling	=	17,400	x 1.121 x 0.982	= 19,154
Corrected Heat of Rejection	=	30,100	x 0.975 x 1.043	= 30,609

Compare the corrected capacities to the load requirements established in Step I. If the capacities are within 10% of the load requirements, the equipment is acceptable. It is better to undersize than oversize as undersizing improves humidity control, reduces sound levels and extends the life of the equipment.

## VI Calculate and assess the water temperature rise.

Calculate the water temperature rise and assess the selection using the following calculation:

$$\text{Actual Temperature Rise} = \frac{\text{Correction Heat of Rejection}}{\text{gpm} \times 500}$$

For example, using the Corrected Heat of Rejection from the last step:

$$\text{Actual Temperature Rise} = \frac{30,609}{4.5 \times 500} = 13.6 \text{ F}$$

If the units selected are not within 10% of the load calculations, review what effect changing the gpm, water temperature and/or airflow will have on the corrected capacities. If the desired capacity cannot be achieved, select the next larger or smaller unit and repeat Steps I through VI.



## VII AHRI/ISO/ASHRAE 13256-1 Conversion

Performance standard AHRI/ISO/ASHRAE 13256-1 became effective on January 1, 2000 and replaced the existing AHRI Standards 320 Water-Loop Heat Pumps (WLHP), 325 Ground-Water Heat Pumps (GWHP), and 330 Ground-Loop Heat Pumps (GLHP).

The AHRI/ISO Standard incorporates a consistent rating methodology for including fan and pump energy for calculating cooling capacity, heating capacity, and energy efficiency ratios (EER). This simplifies the use of rating data for heat pump performance modeling in seasonal energy analysis calculations, and allows for direct rating comparisons across applications.

### a) ISO Capacity and Efficiency Equations

The following equations are used to calculate and correct cooling capacity, heating capacity, and respective EER:

$$\text{ISO Cooling Capacity} = (\text{Cooling Capacity in Btuh}) + (\text{Fan Power Correction in watts} \times 3.412)$$

$$\text{ISO Cooling EER} = (\text{ISO Cooling Capacity in Btuh}/3.412)/(\text{Power Input in watts} - \text{Fan Power Correction in watts} + \text{Pump Power Correction in watts}) = \text{watts/watts}$$

NOTE: Do not divide ISO Cooling Capacity by 3.412 to obtain Btuh/watts.

$$\text{ISO Heating Capacity} = (\text{Heating Capacity in Btuh}) - (\text{Fan Power Correction in watts} \times 3.412)$$

$$\text{ISO Heating EER} = (\text{ISO Heating Capacity in Btuh}/3.412)/(\text{Power Input in watts} - \text{Fan Power Correction in watts} + \text{Pump Power Correction in watts}) = \text{watts/watts}$$

NOTE: Do not divide ISO Heating Capacity by 3.412 to obtain Btuh/watts.

Refer to English to SI conversion table in this book.

### b) Identify the design conditions corrected for air and water conditions.

$$\text{Airflow Cfm} = 700 \text{ cfm}$$

Water Flow

$$(\text{Based upon } 12 \text{ F rise in temp}) = 4.5 \text{ gpm}$$

$$\text{External Static Pressure} = 0.4 \text{ in. wg}$$

$$\text{Water Pressure Drop} = 8.1 \text{ ft of head}$$

$$\text{Power input} = 2,010 \text{ watts}$$

$$\text{Cooling Capacity} = 22,360 \text{ Btuh}$$

### c) Perform Fan Power Correction Adjustment

Use the following formula to calculate Fan Power Correction:

Fan Power

$$\begin{aligned} \text{Correction} &= (\text{Cfm} \times 0.472) \times (\text{External Static Pressure} \times 249)/300 = \text{watts} \\ &= (700 \times 0.472) \times (0.4 \times 249)/300 \\ &= 110 \text{ watts} \end{aligned}$$

### d) Perform Pump Power Correction Adjustment

Use the following formula to calculate Pump Power Correction:

Pump Power

$$\begin{aligned} \text{Correction} &= (\text{Gpm} \times 0.0631) \times (\text{Pressure Drop} \times 2,990)/300 \\ &= \text{watts} \\ &= (4.5 \times 0.0631) \times \\ &\quad (8.1 \times 2,990)/300 \\ &= 23 \text{ watts} \end{aligned}$$

### e) Perform capacity and EER calculations

Use the following formula to calculate capacity and EER:

ISO Cooling

$$\begin{aligned} \text{Capacity} &= (\text{Cooling Capacity}) + (\text{Fan Power Correction} \times 3.412) \\ &= 22,360 + (110 \times 3.412) \\ &= 22,735 \text{ Btuh} \end{aligned}$$

### f) Perform Corrections by using the ISO Equations

$$\begin{aligned} \text{ISO EER} &= (\text{ISO Cooling Capacity}/3.412)/ \\ &\quad (\text{Power Input} - \text{Fan Power Correction} + \text{Pump Power Correction}) \\ &= \text{watts/watts} \end{aligned}$$

NOTE: Do not divide ISO Cooling Capacity by 3.412 to obtain Btuh/Watts.

$$\begin{aligned} &= (22,735/3.412)/(2,010 - 110 + 23) \\ &= 3.47 \text{ watts/watts} \times \\ &\quad 3.412 \text{ Btuh/watts} \\ &= 11.82 \text{ Btuh/watts} \end{aligned}$$

# Performance data



## 50PCH,PCV006 — 220 CFM NOMINAL AIRFLOW

EWT (F)	GPM	WPD		COOLING - EWT 80/67 F							HEATING - EAT 70 F					
		PSI	ft wg	Airflow CFM	TC	SC	Sensible/Total Ratio	kW	HR	EER	Airflow CFM	HC	kW	HE	LAT	COP
20	1.5	1.7	4.0	Operation Not Recommended							170	4.3	0.49	2.7	93.3	2.6
	1.5	1.7	4.0	Operation Not Recommended							225	4.4	0.44	2.9	88.0	2.9
30	0.8	0.5	1.2	170	7.4	4.2	0.57	0.28	8.4	26.4	170	4.6	0.50	3.0	95.2	2.7
	0.8	0.5	1.2	225	7.7	4.8	0.62	0.29	8.7	26.4	225	4.7	0.45	3.2	89.5	3.1
	1.1	0.8	1.8	170	7.4	4.1	0.55	0.26	8.3	28.5	170	4.8	0.51	3.2	96.2	2.8
	1.1	0.8	1.8	225	7.7	4.6	0.60	0.27	8.6	28.5	225	4.9	0.46	3.4	90.3	3.2
	1.5	1.3	2.9	170	7.3	4.0	0.54	0.25	8.2	29.2	170	4.9	0.51	3.2	96.8	2.8
	1.5	1.3	2.9	225	7.6	4.5	0.59	0.26	8.5	29.2	225	5.0	0.46	3.5	90.7	3.2
40	0.8	0.4	0.9	170	7.3	4.3	0.59	0.31	8.3	23.2	170	5.3	0.52	3.6	98.8	3.0
	0.8	0.4	0.9	225	7.6	4.8	0.64	0.33	8.7	23.2	225	5.4	0.47	3.8	92.3	3.4
	1.1	0.6	1.4	170	7.4	4.2	0.57	0.29	8.4	25.8	170	5.5	0.53	3.8	100.2	3.1
	1.1	0.6	1.4	225	7.7	4.8	0.62	0.30	8.7	25.8	225	5.7	0.47	4.1	93.3	3.5
	1.5	1.0	2.4	170	7.4	4.2	0.56	0.28	8.4	26.9	170	5.7	0.53	3.9	100.9	3.1
50	0.8	0.3	0.8	170	6.9	4.2	0.61	0.35	8.1	19.9	170	6.0	0.54	4.2	102.7	3.3
	0.8	0.3	0.8	225	7.2	4.8	0.66	0.36	8.5	19.9	225	6.1	0.48	4.5	95.3	3.7
	1.1	0.5	1.2	170	7.2	4.3	0.59	0.32	8.3	22.5	170	6.3	0.55	4.5	104.4	3.4
	1.1	0.5	1.2	225	7.5	4.8	0.64	0.33	8.6	22.5	225	6.5	0.49	4.8	96.6	3.9
	1.5	0.9	2.0	170	7.3	4.3	0.58	0.31	8.3	23.8	170	6.5	0.55	4.6	105.4	3.4
	1.5	0.9	2.0	225	7.6	4.8	0.63	0.32	8.7	23.8	225	6.7	0.50	5.0	97.4	3.9
60	0.8	0.3	0.6	170	6.5	4.1	0.63	0.39	7.9	16.8	170	6.7	0.56	4.9	106.7	3.5
	0.8	0.3	0.6	225	6.8	4.7	0.69	0.40	8.2	16.8	225	6.9	0.50	5.2	98.4	4.0
	1.1	0.5	1.0	170	6.9	4.2	0.61	0.36	8.1	19.1	170	7.1	0.57	5.2	108.6	3.7
	1.1	0.5	1.0	225	7.1	4.8	0.67	0.37	8.4	19.1	225	7.3	0.51	5.5	99.9	4.2
	1.5	0.8	1.8	170	7.0	4.2	0.61	0.34	8.2	20.4	170	7.3	0.57	5.3	109.7	3.7
70	1.5	0.8	1.8	225	7.3	4.8	0.66	0.36	8.5	20.4	225	7.5	0.51	5.7	100.7	4.3
	0.8	0.2	0.5	170	6.0	4.0	0.66	0.43	7.5	14.0	170	7.4	0.58	5.5	110.5	3.8
	0.8	0.2	0.5	225	6.3	4.5	0.72	0.45	7.8	14.0	225	7.6	0.52	5.9	101.4	4.3
	1.1	0.4	0.9	170	6.4	4.1	0.64	0.40	7.8	16.0	170	7.8	0.58	5.8	112.4	3.9
	1.1	0.4	0.9	225	6.7	4.6	0.70	0.42	8.1	16.0	225	8.0	0.53	6.2	102.8	4.5
	1.5	0.7	1.6	170	6.6	4.1	0.63	0.38	7.9	17.1	170	8.0	0.59	5.9	113.4	4.0
80	1.5	0.7	1.6	225	6.8	4.7	0.69	0.40	8.2	17.1	225	8.2	0.53	6.4	103.6	4.5
	0.8	0.2	0.5	170	5.6	3.8	0.68	0.47	7.2	12.0	170	7.9	0.59	5.9	113.2	4.0
	0.8	0.2	0.5	225	5.8	4.3	0.74	0.49	7.5	12.0	225	8.1	0.53	6.3	103.5	4.5
	1.1	0.4	0.8	170	5.9	3.9	0.67	0.45	7.4	13.2	170	8.3	0.60	6.3	115.4	4.1
	1.1	0.4	0.8	225	6.1	4.4	0.73	0.46	7.7	13.2	225	8.5	0.54	6.7	105.1	4.6
85	1.5	0.6	1.5	170	6.2	4.0	0.65	0.42	7.6	14.7	170	8.4	0.60	6.3	115.7	4.1
	1.5	0.6	1.5	225	6.4	4.6	0.71	0.44	7.9	14.7	225	8.6	0.54	6.7	105.3	4.6
	0.8	0.2	0.5	170	5.3	3.7	0.70	0.5	7.0	10.7	170	8.2	0.60	6.2	114.7	4.0
	0.8	0.2	0.5	225	5.5	4.2	0.76	0.52	7.3	10.7	225	8.4	0.5	6.6	104.6	4.6
	1.1	0.3	0.8	170	5.6	3.8	0.68	0.47	7.2	11.9	170	8.5	0.6	6.4	116.2	4.1
	1.1	0.3	0.8	225	5.8	4.3	0.74	0.49	7.5	11.9	225	8.7	0.5	6.8	105.8	4.7
90	1.5	0.6	1.4	170	5.8	3.9	0.67	0.45	7.4	13.1	170	8.5	0.6	6.4	116.4	4.1
	1.5	0.6	1.4	225	6.1	4.4	0.73	0.47	7.7	13.1	225	8.7	0.5	6.8	105.9	4.7
	0.8	0.2	0.4	170	5.0	3.6	0.72	0.53	6.7	9.4	170	8.5	0.61	6.4	116.3	4.1
	0.8	0.2	0.4	225	5.2	4.1	0.79	0.55	7.0	9.4	225	8.7	0.55	6.8	105.8	4.7
	1.1	0.3	0.7	170	5.3	3.7	0.70	0.49	7.0	10.7	170	8.6	0.62	6.5	117.0	4.1
100	1.1	0.3	0.7	225	5.5	4.2	0.76	0.52	7.3	10.7	225	8.8	0.55	7.0	106.4	4.7
	1.5	0.6	1.3	170	5.5	3.8	0.69	0.48	7.1	11.5	170	8.7	0.62	6.5	117.1	4.1
	1.5	0.6	1.3	225	5.7	4.3	0.75	0.50	7.4	11.5	225	8.9	0.56	7.0	106.5	4.7
	0.8	0.2	0.4	170	4.4	3.4	0.76	0.58	6.4	7.6						
	0.8	0.2	0.4	225	4.6	3.8	0.83	0.60	6.6	7.6						
	1.1	0.3	0.7	170	4.7	3.5	0.74	0.55	6.6	8.7						
110	1.1	0.3	0.7	225	4.9	4.0	0.80	0.57	6.9	8.7						
	1.5	0.5	1.2	170	4.9	3.6	0.73	0.53	6.7	9.3						
	1.5	0.5	1.2	225	5.1	4.0	0.79	0.55	7.0	9.3						
	0.8	0.2	0.3	170	3.9	3.1	0.81	0.63	6.0	6.2						
	0.8	0.2	0.3	225	4.1	3.6	0.87	0.66	6.3	6.2						
120	1.1	0.3	0.6	170	4.2	3.3	0.78	0.60	6.2	7.0						
	1.1	0.3	0.6	225	4.4	3.7	0.85	0.62	6.5	7.0						
	1.5	0.5	1.2	170	4.3	3.3	0.77	0.58	6.3	7.4						
	1.5	0.5	1.2	225	4.5	3.8	0.83	0.61	6.6	7.4						
120	0.8	0.1	0.3	170	3.5	3.0	0.85	0.68	5.8	5.0						
	0.8	0.1	0.3	225	3.6	3.3	0.93	0.71	6.0	5.0						
	1.1	0.3	0.6	170	3.7	3.0	0.83	0.65	5.9	5.6						
	1.1	0.3	0.6	225	3.8	3.4	0.90	0.68	6.2	5.6						
	1.5	0.5	1.1	170	3.8	3.1	0.81	0.64	6.0	6.0						
	1.5	0.5	1.1	225	4.0	3.5	0.88	0.67	6.2	6.0						

Operation Not Recommended

NOTE: See Legend and Notes on page 25.



50PCH,PCV009 — 325 CFM NOMINAL AIRFLOW

EWT (F)	GPM	WPD		COOLING - EWT 80/67 F							HEATING - EAT 70 F					
		PSI	ft wg	Airflow CFM	TC	SC	Sensible/Total Ratio	kW	HR	EER	Airflow CFM	HC	kW	HE	LAT	COP
20	2.3	4.5	10.5	Operation Not Recommended							250	6.5	0.73	4.2	94.2	2.6
	2.3	4.5	10.5	Operation Not Recommended							330	6.7	0.66	4.4	88.8	3.0
30	1.1	1.3	3.0	250	10.2	6.0	0.59	0.39	11.6	26.6	250	7.1	0.74	4.7	96.3	2.8
	1.1	1.3	3.0	330	10.7	6.8	0.64	0.40	12.0	26.6	330	7.3	0.67	5.0	90.4	3.2
	1.7	1.9	4.4	250	10.5	6.0	0.57	0.36	11.7	29.5	250	7.4	0.75	4.9	97.4	2.9
	1.7	1.9	4.4	330	10.9	6.8	0.62	0.37	12.2	29.5	330	7.6	0.67	5.3	91.2	3.3
	2.3	3.5	8.1	250	10.6	6.0	0.56	0.34	11.8	31.1	250	7.5	0.75	5.1	97.9	2.9
	2.3	3.5	8.1	330	11.0	6.8	0.61	0.36	12.3	31.1	330	7.7	0.68	5.4	91.7	3.4
40	1.1	0.9	2.0	250	9.9	6.0	0.61	0.43	11.3	22.8	250	8.0	0.76	5.5	99.8	3.1
	1.1	0.9	2.0	330	10.3	6.8	0.66	0.45	11.8	22.8	330	8.2	0.69	5.9	93.1	3.5
	1.7	1.5	3.5	250	10.1	6.0	0.59	0.40	11.5	25.4	250	8.4	0.77	5.8	101.1	3.2
	1.7	1.5	3.5	330	10.5	6.8	0.64	0.41	12.0	25.4	330	8.6	0.69	6.2	94.1	3.6
	2.3	3.0	6.8	250	10.3	6.0	0.59	0.38	11.6	26.8	250	8.6	0.78	6.0	101.8	3.2
	2.3	3.0	6.8	330	10.7	6.8	0.64	0.40	12.0	26.9	330	8.8	0.70	6.4	94.7	3.7
50	1.1	0.6	1.5	250	9.4	6.0	0.63	0.48	11.1	19.5	250	9.0	0.79	6.4	103.3	3.4
	1.1	0.6	1.5	330	9.8	6.7	0.69	0.50	11.6	19.5	330	9.2	0.71	6.8	95.8	3.8
	1.7	1.3	2.9	250	9.7	6.0	0.62	0.45	11.3	21.7	250	9.4	0.80	6.7	104.8	3.5
	1.7	1.3	2.9	330	10.1	6.8	0.67	0.47	11.7	21.7	330	9.6	0.72	7.2	97.0	3.9
	2.3	2.6	6.0	250	9.9	6.0	0.61	0.43	11.3	23.0	250	9.6	0.80	6.9	105.6	3.5
	2.3	2.6	6.0	330	10.3	6.8	0.66	0.45	11.8	23.0	330	9.8	0.72	7.4	97.6	4.0
60	1.1	0.5	1.2	250	9.0	5.9	0.65	0.54	10.8	16.5	250	9.9	0.81	7.2	106.8	3.6
	1.1	0.5	1.2	330	9.4	6.7	0.71	0.57	11.3	16.5	330	10.2	0.73	7.7	98.5	4.1
	1.7	1.1	2.5	250	9.3	5.9	0.64	0.50	11.0	18.5	250	10.4	0.82	7.6	108.4	3.7
	1.7	1.1	2.5	330	9.7	6.7	0.69	0.52	11.5	18.5	330	10.6	0.74	8.1	99.8	4.2
	2.3	2.3	5.4	250	9.5	6.0	0.63	0.48	11.1	19.6	250	10.6	0.83	7.8	109.3	3.7
	2.3	2.3	5.4	330	9.8	6.7	0.69	0.50	11.6	19.6	330	10.9	0.75	8.3	100.5	4.3
70	1.1	0.4	0.9	250	8.5	5.8	0.68	0.61	10.6	14.0	250	10.8	0.84	8.0	110.1	3.8
	1.1	0.4	0.9	330	8.8	6.5	0.74	0.63	11.0	14.0	330	11.1	0.75	8.5	101.1	4.3
	1.7	1.0	2.3	250	8.8	5.8	0.66	0.56	10.7	15.6	250	11.3	0.85	8.4	111.9	3.9
	1.7	1.0	2.3	330	9.2	6.6	0.72	0.59	11.2	15.6	330	11.6	0.77	9.0	102.5	4.4
	2.3	2.1	4.9	250	9.1	5.9	0.65	0.53	10.9	17.1	250	11.4	0.85	8.5	112.1	3.9
	2.3	2.1	4.9	330	9.5	6.7	0.71	0.55	11.3	17.1	330	11.6	0.77	9.0	102.7	4.4
80	1.1	0.3	0.8	250	8.0	5.6	0.70	0.67	10.3	11.8	250	11.7	0.87	8.7	113.3	4.0
	1.1	0.3	0.8	330	8.3	6.3	0.77	0.70	10.7	11.8	330	12.0	0.78	9.3	103.6	4.5
	1.7	0.9	2.1	250	8.3	5.7	0.69	0.63	10.5	13.2	250	12.2	0.88	9.1	115.1	4.0
	1.7	0.9	2.1	330	8.6	6.5	0.75	0.66	10.9	13.2	330	12.5	0.79	9.8	105.0	4.6
	2.3	2.0	4.6	250	8.6	5.8	0.67	0.59	10.6	14.4	250	12.2	0.88	9.2	115.4	4.1
	2.3	2.0	4.6	330	8.9	6.5	0.73	0.62	11.1	14.4	330	12.5	0.79	9.8	105.2	4.6
85	1.1	0.3	0.7	250	7.7	5.5	0.71	0.67	10.1	11.0	250	12.0	0.88	9.0	114.5	4.0
	1.1	0.3	0.7	330	8.0	6.2	0.78	0.73	10.5	11.0	330	12.3	0.8	9.6	104.6	4.6
	1.7	0.9	2.0	250	8.0	5.6	0.70	0.67	10.3	12.1	250	12.6	0.9	9.5	116.5	4.1
	1.7	0.9	2.0	330	8.4	6.4	0.76	0.69	10.7	12.1	330	12.9	0.8	10.1	106.1	4.7
	2.3	1.9	4.4	250	8.3	5.7	0.69	0.63	10.5	13.3	250	12.6	0.9	9.5	116.8	4.1
	2.3	1.9	4.4	330	8.7	6.5	0.75	0.65	10.9	13.3	330	12.9	0.8	10.2	106.3	4.7
90	1.1	0.3	0.6	250	7.5	5.4	0.72	0.73	10.0	10.2	250	12.3	0.89	9.3	115.7	4.1
	1.1	0.3	0.6	330	7.8	6.2	0.79	0.76	10.4	10.2	330	12.6	0.80	9.9	105.5	4.6
	1.7	0.8	1.9	250	7.7	5.5	0.71	0.70	10.1	11.1	250	12.9	0.91	9.8	117.9	4.2
	1.7	0.8	1.9	330	8.1	6.3	0.78	0.73	10.6	11.1	330	13.3	0.82	10.5	107.2	4.8
	2.3	1.8	4.3	250	8.0	5.6	0.70	0.66	10.3	12.1	250	13.0	0.91	9.9	118.2	4.2
	2.3	1.8	4.3	330	8.4	6.4	0.76	0.69	10.7	12.1	330	13.3	0.82	10.5	107.4	4.8
100	1.1	0.2	0.6	250	6.8	5.1	0.76	0.82	9.6	8.2	Operation Not Recommended					
	1.1	0.2	0.6	330	7.0	5.8	0.82	0.86	10.0	8.2						
	1.7	0.8	1.7	250	7.1	5.3	0.74	0.78	9.8	9.2						
	1.7	0.8	1.7	330	7.4	6.0	0.81	0.81	10.2	9.2						
	2.3	1.7	4.0	250	7.3	5.4	0.73	0.75	9.9	9.7						
	2.3	1.7	4.0	330	7.6	6.1	0.80	0.78	10.3	9.7						
110	1.1	0.2	0.5	250	6.1	4.8	0.79	0.90	9.2	6.8	Operation Not Recommended					
	1.1	0.2	0.5	330	6.3	5.4	0.85	0.94	9.5	6.8						
	1.7	0.7	1.6	250	6.5	5.0	0.77	0.86	9.4	7.6						
	1.7	0.7	1.6	330	6.8	5.6	0.84	0.89	9.8	7.6						
	2.3	1.6	3.8	250	6.7	5.1	0.76	0.83	9.5	8.0						
	2.3	1.6	3.8	330	7.0	5.8	0.83	0.87	9.9	8.0						
120	1.1	0.2	0.4	250	5.4	4.4	0.82	0.98	8.7	5.5	Operation Not Recommended					
	1.1	0.2	0.4	330	5.6	5.0	0.89	1.02	9.1	5.5						
	1.7	0.7	1.6	250	5.8	4.6	0.80	0.94	9.0	6.2						
	1.7	0.7	1.6	330	6.0	5.2	0.87	0.98	9.4	6.2						
	2.3	1.6	3.6	250	6.0	4.7	0.79	0.91	9.1	6.5						
	2.3	1.6	3.6	330	6.2	5.4	0.86	0.95	9.5	6.5						

NOTE: See Legend and Notes on page 25.

# Performance data (cont)



## 50PCH,PCV012 — 400 CFM NOMINAL AIRFLOW

EWT (F)	GPM	WPD		COOLING - EWT 80/67 F							HEATING - EAT 70 F					
		PSI	ft wg	Airflow CFM	TC	SC	Sensible/Total Ratio	kW	HR	EER	Airflow CFM	HC	kW	HE	LAT	COP
20	3.0	8.5	19.6	Operation Not Recommended							300	8.5	0.98	5.3	96.2	2.5
	3.0	8.5	19.6	Operation Not Recommended							400	8.7	0.88	5.7	90.2	2.9
30	1.5	1.9	4.3	300	14.2	8.2	0.58	0.55	16.1	25.8	300	9.3	1.00	6.0	98.6	2.7
	1.5	1.9	4.3	400	14.8	9.3	0.63	0.57	16.8	25.8	400	9.5	0.90	6.4	91.9	3.1
	2.3	3.6	8.4	300	14.3	8.2	0.58	0.51	16.1	27.9	300	9.6	1.01	6.3	99.7	2.8
	2.3	3.6	8.4	400	14.9	9.3	0.63	0.53	16.7	27.9	400	9.9	0.91	6.8	92.8	3.2
	3.0	6.7	15.5	300	14.3	8.2	0.58	0.50	16.0	28.8	300	9.8	1.02	6.5	100.4	2.8
	3.0	6.7	15.5	400	14.9	9.3	0.63	0.52	16.6	28.8	400	10.1	0.92	7.0	93.3	3.2
40	1.5	1.4	3.2	300	14.0	8.1	0.58	0.61	16.0	22.9	300	10.6	1.04	7.1	102.6	3.0
	1.5	1.4	3.2	400	14.5	9.2	0.63	0.63	16.7	22.9	400	10.8	0.93	7.6	95.0	3.4
	2.3	3.0	6.9	300	14.2	8.2	0.58	0.57	16.1	25.1	300	11.0	1.05	7.6	104.1	3.1
	2.3	3.0	6.9	400	14.8	9.3	0.63	0.59	16.8	25.1	400	11.3	0.94	8.1	96.2	3.5
	3.0	5.7	13.1	300	14.3	8.2	0.58	0.54	16.1	26.2	300	11.3	1.06	7.8	104.9	3.1
	3.0	5.7	13.1	400	14.8	9.3	0.63	0.57	16.8	26.2	400	11.6	0.95	8.3	96.8	3.6
50	1.5	1.1	2.5	300	13.5	7.9	0.58	0.67	15.8	20.1	300	11.9	1.08	8.3	106.8	3.2
	1.5	1.1	2.5	400	14.1	8.9	0.63	0.70	16.5	20.1	400	12.2	0.97	8.9	98.2	3.7
	2.3	2.6	6.0	300	13.9	8.0	0.58	0.62	16.0	22.2	300	12.5	1.09	8.9	108.6	3.4
	2.3	2.6	6.0	400	14.4	9.1	0.63	0.65	16.7	22.2	400	12.8	0.98	9.5	99.6	3.8
	3.0	5.0	11.5	300	14.0	8.1	0.58	0.60	16.1	23.3	300	12.8	1.10	9.1	109.6	3.4
	3.0	5.0	11.5	400	14.6	9.2	0.63	0.63	16.7	23.3	400	13.1	0.99	9.8	100.4	3.9
60	1.5	0.9	2.1	300	12.9	7.6	0.59	0.74	15.5	17.4	300	13.3	1.11	9.6	111.1	3.5
	1.5	0.9	2.1	400	13.5	8.6	0.64	0.77	16.1	17.4	400	13.6	1.00	10.2	101.5	4.0
	2.3	2.3	5.3	300	13.4	7.8	0.58	0.69	15.7	19.3	300	14.0	1.13	10.2	113.1	3.6
	2.3	2.3	5.3	400	13.9	8.8	0.63	0.72	16.4	19.3	400	14.3	1.02	10.8	103.1	4.1
	3.0	4.5	10.3	300	13.6	7.9	0.58	0.67	15.8	20.4	300	14.3	1.14	10.5	114.2	3.7
	3.0	4.5	10.3	400	14.1	8.9	0.63	0.69	16.5	20.4	400	14.7	1.03	11.2	104.0	4.2
70	1.5	0.8	1.8	300	12.2	7.3	0.60	0.82	15.0	14.9	300	14.7	1.15	10.8	115.3	3.7
	1.5	0.8	1.8	400	12.7	8.3	0.65	0.85	15.6	14.9	400	15.0	1.04	11.5	104.8	4.2
	2.3	2.1	4.8	300	12.5	7.4	0.59	0.77	15.2	16.3	300	15.4	1.18	11.4	117.6	3.8
	2.3	2.1	4.8	400	13.1	8.4	0.64	0.80	15.8	16.3	400	15.8	1.06	12.2	106.5	4.4
	3.0	4.1	9.5	300	12.7	7.5	0.59	0.75	15.3	17.0	300	15.8	1.19	11.7	118.8	3.9
	3.0	4.1	9.5	400	13.3	8.5	0.64	0.78	15.9	17.0	400	16.2	1.07	12.5	107.5	4.4
80	1.5	0.7	1.5	300	11.4	7.0	0.61	0.90	14.5	12.7	300	16.0	1.20	11.9	119.4	3.9
	1.5	0.7	1.5	400	11.9	7.9	0.67	0.94	15.1	12.7	400	16.4	1.08	12.7	108.0	4.5
	2.3	1.9	4.4	300	11.8	7.1	0.60	0.85	14.7	13.9	300	16.8	1.22	12.6	121.7	4.0
	2.3	1.9	4.4	400	12.3	8.0	0.65	0.88	15.3	13.9	400	17.2	1.10	13.4	109.8	4.6
	3.0	3.8	8.8	300	12.0	7.2	0.60	0.83	14.8	14.5	300	17.2	1.24	12.9	123.0	4.1
	3.0	3.8	8.8	400	12.5	8.1	0.65	0.86	15.4	14.5	400	17.6	1.11	13.8	110.7	4.6
85	1.5	0.6	1.5	300	10.9	6.8	0.62	0.9	14.2	11.7	300	16.6	1.22	12.5	121.3	4.0
	1.5	0.6	1.5	400	11.4	7.7	0.68	0.98	14.7	11.7	400	17.0	1.1	13.3	109.4	4.6
	2.3	1.8	4.2	300	11.4	6.9	0.61	0.89	14.4	12.8	300	17.4	1.3	13.1	123.6	4.1
	2.3	1.8	4.2	400	11.9	7.9	0.66	0.93	15.0	12.8	400	17.8	1.1	14.0	111.2	4.6
	3.0	3.7	8.5	300	11.6	7.0	0.60	0.87	14.5	13.4	300	17.7	1.3	13.4	124.8	4.1
	3.0	3.7	8.5	400	12.1	7.9	0.66	0.90	15.1	13.4	400	18.2	1.1	14.3	112.1	4.7
90	1.5	0.6	1.4	300	10.5	6.7	0.63	0.99	13.9	10.7	300	17.3	1.24	13.0	123.3	4.1
	1.5	0.6	1.4	400	10.9	7.5	0.69	1.03	14.4	10.7	400	17.7	1.12	13.9	110.9	4.6
	2.3	1.8	4.1	300	11.0	6.8	0.62	0.93	14.1	11.7	300	18.0	1.28	13.6	125.5	4.1
	2.3	1.8	4.1	400	11.4	7.7	0.67	0.97	14.7	11.7	400	18.4	1.15	14.5	112.6	4.7
	3.0	3.6	8.2	300	11.2	6.8	0.61	0.91	14.3	12.3	300	18.3	1.29	13.9	126.6	4.2
	3.0	3.6	8.2	400	11.6	7.7	0.67	0.95	14.8	12.3	400	18.8	1.16	14.8	113.5	4.7
100	1.5	0.5	1.2	300	9.5	6.4	0.67	1.07	13.2	8.9	Operation Not Recommended					
	1.5	0.5	1.2	400	9.9	7.2	0.72	1.12	13.8	8.9	Operation Not Recommended					
	2.3	1.7	3.8	300	10.1	6.5	0.65	1.02	13.5	9.8	Operation Not Recommended					
	2.3	1.7	3.8	400	10.5	7.3	0.70	1.06	14.1	9.8	Operation Not Recommended					
	3.0	3.3	7.7	300	10.4	6.6	0.64	1.00	13.8	10.4	Operation Not Recommended					
	3.0	3.3	7.7	400	10.8	7.5	0.69	1.04	14.3	10.4	Operation Not Recommended					
110	1.5	0.5	1.1	300	8.5	6.0	0.71	1.17	12.5	7.3	Operation Not Recommended					
	1.5	0.5	1.1	400	8.9	6.8	0.77	1.22	13.1	7.3	Operation Not Recommended					
	2.3	1.6	3.6	300	9.1	6.2	0.68	1.12	12.9	8.1	Operation Not Recommended					
	2.3	1.6	3.6	400	9.4	7.0	0.74	1.16	13.4	8.1	Operation Not Recommended					
	3.0	3.2	7.3	300	9.4	6.3	0.67	1.09	13.1	8.6	Operation Not Recommended					
	3.0	3.2	7.3	400	9.8	7.1	0.73	1.14	13.7	8.6	Operation Not Recommended					
120	1.5	0.4	1.0	300	7.5	5.7	0.76	1.27	11.8	5.9	Operation Not Recommended					
	1.5	0.4	1.0	400	7.8	6.4	0.82	1.32	12.3	5.9	Operation Not Recommended					
	2.3	1.5	3.4	300	8.0	5.8	0.73	1.22	12.2	6.6	Operation Not Recommended					
	2.3	1.5	3.4	400	8.3	6.6	0.79	1.27	12.7	6.6	Operation Not Recommended					
	3.0	3.0	7.0	300	8.3	5.9	0.71	1.19	12.4	7.0	Operation Not Recommended					
	3.0	3.0	7.0	400	8.7	6.7	0.77	1.24	12.9	7.0	Operation Not Recommended					

NOTE: See Legend and Notes on page 25.





### 50PCH,PCV015 — 525 CFM NOMINAL AIRFLOW

EWT (F)	GPM	WPD		COOLING - EWT 80/67 F							HEATING - EAT 70 F					
		PSI	ft wg	Airflow CFM	TC	SC	Sensible/ Total Ratio	kW	HR	EER	Airflow CFM	HC	kW	HE	LAT	COP
20	3.8	4.1	9.5	Operation Not Recommended							395	9.5	1.07	6.1	92	2.62
	3.8	4.1	9.5	Operation Not Recommended							525	9.8	0.96	6.5	87	2.98
30	1.9	1.0	2.3	395	17.3	10.8	0.62	0.61	19.4	28.4	395	10.6	1.09	7.1	95	2.84
	1.9	1.0	2.3	525	18.1	12.2	0.67	0.64	20.2	28.4	525	10.9	0.98	7.5	89	3.24
	2.8	1.8	4.3	395	17.5	10.8	0.62	0.56	19.4	31.1	395	11.1	1.11	7.5	96	2.94
	2.8	1.8	4.3	525	18.2	12.2	0.67	0.59	20.2	31.1	525	11.4	0.99	8.0	90	3.35
	3.8	3.3	7.7	395	17.5	10.8	0.62	0.54	19.4	32.2	395	11.3	1.11	7.7	97	2.99
	3.8	3.3	7.7	525	18.3	12.2	0.67	0.57	20.2	32.2	525	11.6	1.00	8.2	90	3.41
40	1.9	0.8	1.8	395	17.0	10.6	0.63	0.68	19.3	24.8	395	12.3	1.13	8.5	99	3.18
	1.9	0.8	1.8	525	17.7	12.0	0.68	0.71	20.1	24.8	525	12.6	1.02	9.1	92	3.62
	2.8	1.6	3.6	395	17.2	10.7	0.62	0.63	19.4	27.3	395	12.8	1.14	9.0	100	3.29
	2.8	1.6	3.6	525	18.0	12.1	0.68	0.66	20.2	27.3	525	13.1	1.03	9.7	93	3.75
	3.8	2.9	6.6	395	17.4	10.8	0.62	0.60	19.4	28.8	395	13.1	1.15	9.3	101	3.35
50	1.9	0.6	1.5	395	16.4	10.4	0.63	0.76	19.0	21.6	395	13.9	1.16	10.0	103	3.50
	1.9	0.6	1.5	525	17.1	11.8	0.69	0.79	19.8	21.6	525	14.2	1.05	10.7	95	3.99
	2.8	1.4	3.1	395	16.8	10.6	0.63	0.71	19.2	23.8	395	14.6	1.18	10.6	104	3.63
	2.8	1.4	3.1	525	17.5	12.0	0.68	0.74	20.0	23.8	525	14.9	1.06	11.3	96	4.13
	3.8	2.5	5.8	395	17.0	10.6	0.63	0.68	19.3	25.0	395	14.9	1.18	10.9	105	3.69
	3.8	2.5	5.8	525	17.7	12.0	0.68	0.71	20.1	25.0	525	15.3	1.06	11.7	97	4.21
	3.8	2.5	5.8	525	17.7	12.0	0.68	0.71	20.1	25.0	525	15.3	1.06	11.7	97	4.21
60	1.9	0.6	1.3	395	15.7	10.2	0.65	0.84	18.6	18.7	395	15.5	1.20	11.5	106	3.81
	1.9	0.6	1.3	525	16.4	11.5	0.70	0.88	19.4	18.7	525	15.9	1.07	12.2	98	4.34
	2.8	1.2	2.8	395	16.2	10.4	0.64	0.79	18.9	20.5	395	16.3	1.21	12.1	108	3.94
	2.8	1.2	2.8	525	16.9	11.7	0.69	0.82	19.7	20.5	525	16.7	1.09	13.0	99	4.50
	3.8	2.3	5.3	395	16.4	10.4	0.63	0.76	19.0	21.6	395	16.7	1.22	12.5	109	4.02
70	1.9	0.5	1.1	395	15.2	10.1	0.66	0.93	18.3	16.2	395	17.1	1.22	12.9	110	4.10
	1.9	0.5	1.1	525	15.8	11.4	0.72	0.97	19.1	16.3	525	17.5	1.10	13.8	101	4.68
	2.8	1.1	2.5	395	15.5	10.1	0.65	0.88	18.5	17.6	395	18.0	1.24	13.7	112	4.25
	2.8	1.1	2.5	525	16.1	11.4	0.71	0.91	19.2	17.6	525	18.4	1.11	14.6	102	4.85
	3.8	2.1	4.9	395	15.8	10.2	0.65	0.85	18.6	18.6	395	18.4	1.25	14.1	113	4.33
	3.8	2.1	4.9	525	16.4	11.5	0.70	0.88	19.4	18.6	525	18.8	1.12	15.0	103	4.94
	3.8	2.1	4.9	525	16.4	11.5	0.70	0.88	19.4	18.6	525	18.8	1.12	15.0	103	4.94
80	1.9	0.4	1.0	395	14.3	9.8	0.68	1.03	17.8	13.9	395	18.7	1.25	14.3	114	4.38
	1.9	0.4	1.0	525	14.9	11.1	0.74	1.07	18.5	13.9	525	19.2	1.12	15.3	104	5.00
	2.8	1.0	2.4	395	14.7	9.8	0.67	0.97	18.0	15.1	395	19.6	1.27	15.1	116	4.54
	2.8	1.0	2.4	525	15.3	11.1	0.73	1.01	18.7	15.1	525	20.1	1.14	16.2	105	5.18
	3.8	2.0	4.6	395	14.9	9.9	0.66	0.94	18.2	15.9	395	20.1	1.27	15.6	117	4.62
85	1.9	0.4	0.9	395	13.8	9.6	0.70	1.10	17.5	12.8	395	19.5	1.26	15.0	116	4.52
	1.9	0.4	0.9	525	14.4	10.9	0.76	1.13	18.2	12.8	525	19.9	1.13	16.0	105	5.15
	2.8	1.0	2.3	395	14.2	9.7	0.68	1.02	17.7	13.9	395	20.4	1.28	15.9	118	4.68
	2.8	1.0	2.3	525	14.8	11.0	0.74	1.07	18.4	13.9	525	20.9	1.15	16.9	107	5.34
	3.8	1.9	4.4	395	14.5	9.8	0.67	0.99	17.9	14.7	395	20.9	1.29	16.3	119	4.77
	3.8	1.9	4.4	525	15.1	11.1	0.73	1.03	18.6	14.7	525	21.4	1.15	17.4	108	5.43
	3.8	1.9	4.4	525	15.1	11.1	0.73	1.03	18.6	14.7	525	21.4	1.15	17.4	108	5.43
90	1.9	0.4	0.9	395	13.3	9.5	0.71	1.14	17.2	11.7	395	20.2	1.28	15.7	117	4.65
	1.9	0.4	0.9	525	13.9	10.7	0.77	1.19	18.0	11.7	525	20.7	1.15	16.8	107	5.30
	2.8	1.0	2.2	395	13.7	9.5	0.69	1.08	17.4	12.8	395	21.2	1.29	16.6	120	4.82
	2.8	1.0	2.2	525	14.3	10.8	0.75	1.12	18.1	12.8	525	21.7	1.16	17.7	108	5.49
	3.8	1.9	4.3	395	14.1	9.6	0.69	1.04	17.6	13.5	395	21.7	1.30	17.1	121	4.90
100	1.9	0.4	0.8	395	12.4	9.2	0.74	1.25	16.6	9.9	395	22.2	1.17	18.2	109	5.59
	1.9	0.4	0.8	525	12.9	10.4	0.80	1.31	17.3	9.9	525	22.2	1.17	18.2	109	5.59
	2.8	0.9	2.1	395	12.8	9.2	0.72	1.19	16.8	10.8	395	22.2	1.17	18.2	109	5.59
	2.8	0.9	2.1	525	13.3	10.4	0.78	1.23	17.5	10.8	525	22.2	1.17	18.2	109	5.59
	3.8	1.8	4.1	395	13.1	9.3	0.71	1.15	17.0	11.4	395	22.2	1.17	18.2	109	5.59
	3.8	1.8	4.1	525	13.6	10.5	0.77	1.20	17.7	11.4	525	22.2	1.17	18.2	109	5.59
	3.8	1.8	4.1	525	13.6	10.5	0.77	1.20	17.7	11.4	525	22.2	1.17	18.2	109	5.59
110	1.9	0.3	0.7	395	11.3	8.8	0.78	1.37	16.0	8.3	395	22.2	1.17	18.2	109	5.59
	1.9	0.3	0.7	525	11.8	10.0	0.84	1.43	16.7	8.3	525	22.2	1.17	18.2	109	5.59
	2.8	0.8	1.9	395	11.8	8.9	0.75	1.30	16.2	9.0	395	22.2	1.17	18.2	109	5.59
	2.8	0.8	1.9	525	12.2	10.0	0.82	1.36	16.9	9.0	525	22.2	1.17	18.2	109	5.59
	3.8	1.7	3.9	395	12.1	9.0	0.74	1.27	16.4	9.5	395	22.2	1.17	18.2	109	5.59
120	1.9	0.3	0.7	395	10.3	8.5	0.82	1.50	15.5	6.9	395	22.2	1.17	18.2	109	5.59
	1.9	0.3	0.7	525	10.8	9.6	0.89	1.56	16.1	6.9	525	22.2	1.17	18.2	109	5.59
	2.8	0.8	1.8	395	10.7	8.5	0.79	1.43	15.6	7.5	395	22.2	1.17	18.2	109	5.59
	2.8	0.8	1.8	525	11.2	9.6	0.86	1.48	16.2	7.5	525	22.2	1.17	18.2	109	5.59
	3.8	1.6	3.7	395	11.0	8.6	0.78	1.39	15.8	7.9	395	22.2	1.17	18.2	109	5.59
3.8	1.6	3.7	525	11.5	9.8	0.85	1.45	16.4	7.9	525	22.2	1.17	18.2	109	5.59	

NOTE: See Legend and Notes on page 25.

# Performance data (cont)



## 50PCH,PCV018 — 600 CFM NOMINAL AIRFLOW

EWT (F)	GPM	WPD		COOLING - EWT 80/67 F							HEATING - EAT 70 F					
		PSI	ft wg	Airflow CFM	TC	SC	Sensible/Total Ratio	kW	HR	EER	Airflow CFM	HC	kW	HE	LAT	COP
20	4.5	7.2	16.7	Operation Not Recommended							450	11.2	1.25	7.2	93	2.61
	4.5	7.2	16.7	Operation Not Recommended							600	11.4	1.13	7.6	88	2.98
30	2.3	2.1	4.9	450	22.1	14.2	0.64	0.72	24.5	30.7	450	12.4	1.29	8.2	96	2.83
	2.3	2.1	4.9	600	23.0	16.1	0.70	0.75	25.5	30.8	600	12.7	1.16	8.8	90	3.22
	3.4	3.4	7.9	450	22.9	14.4	0.63	0.64	25.1	35.8	450	12.9	1.30	8.7	97	2.92
	3.4	3.4	7.9	600	23.9	16.3	0.68	0.67	26.1	35.8	600	13.3	1.17	9.3	90	3.33
	4.5	5.9	13.7	450	23.3	14.4	0.62	0.60	25.3	39.0	450	13.2	1.31	9.0	97	2.97
	4.5	5.9	13.7	600	24.3	16.3	0.67	0.62	26.4	39.0	600	13.5	1.17	9.6	91	3.38
40	2.3	1.7	3.9	450	21.1	13.9	0.66	0.82	23.9	25.6	450	14.3	1.33	9.9	99	3.15
	2.3	1.7	3.9	600	22.0	15.7	0.72	0.86	24.9	25.6	600	14.7	1.20	10.6	93	3.59
	3.4	2.9	6.7	450	21.9	14.2	0.65	0.75	24.4	29.3	450	15.0	1.35	10.5	101	3.26
	3.4	2.9	6.7	600	22.8	16.0	0.70	0.78	25.4	29.3	600	15.3	1.21	11.2	94	3.72
	4.5	5.1	11.8	450	22.5	14.5	0.64	0.71	24.9	31.9	450	15.3	1.35	10.8	102	3.32
50	2.3	1.4	3.3	450	20.4	13.7	0.67	0.93	23.5	21.9	450	16.3	1.37	11.7	103	3.47
	2.3	1.4	3.3	600	21.2	15.5	0.73	0.97	24.5	22.0	600	16.6	1.23	12.5	96	3.96
	3.4	2.6	5.9	450	20.8	13.8	0.66	0.85	23.7	24.4	450	17.0	1.39	12.4	105	3.60
	3.4	2.6	5.9	600	21.7	15.6	0.72	0.89	24.7	24.4	600	17.4	1.25	13.2	97	4.10
	4.5	4.6	10.6	450	21.2	13.9	0.66	0.81	23.9	26.1	450	17.4	1.39	12.7	106	3.67
	4.5	4.6	10.6	600	22.1	15.8	0.72	0.85	24.9	26.1	600	17.9	1.25	13.6	98	4.18
60	2.3	1.3	2.9	450	19.3	13.2	0.68	1.04	22.8	18.6	450	18.2	1.41	13.4	107	3.79
	2.3	1.3	2.9	600	20.1	14.9	0.74	1.08	23.8	18.6	600	18.6	1.26	14.3	99	4.32
	3.4	2.3	5.3	450	19.8	13.4	0.68	0.96	23.0	20.6	450	19.1	1.42	14.2	109	3.93
	3.4	2.3	5.3	600	20.6	15.1	0.73	1.00	24.0	20.6	600	19.6	1.28	15.2	100	4.49
	4.5	4.2	9.6	450	20.1	13.5	0.67	0.92	23.3	21.9	450	19.6	1.43	14.7	110	4.01
70	2.3	1.1	2.6	450	18.2	12.7	0.69	1.15	22.1	15.8	450	20.2	1.44	15.2	112	4.11
	2.3	1.1	2.6	600	19.0	14.3	0.76	1.20	23.1	15.8	600	20.7	1.29	16.2	102	4.68
	3.4	2.1	4.9	450	18.7	12.8	0.69	1.07	22.3	17.4	450	21.2	1.46	16.1	114	4.27
	3.4	2.1	4.9	600	19.4	14.5	0.75	1.12	23.2	17.4	600	21.7	1.31	17.2	103	4.86
	4.5	3.9	8.9	450	19.1	13.0	0.68	1.03	22.6	18.4	450	21.7	1.46	16.6	115	4.35
	4.5	3.9	8.9	600	19.8	14.7	0.74	1.08	23.5	18.4	600	22.3	1.32	17.8	104	4.96
80	2.3	1.0	2.3	450	17.0	12.1	0.71	1.28	21.4	13.3	450	22.1	1.47	17.0	116	4.41
	2.3	1.0	2.3	600	17.7	13.7	0.77	1.33	22.3	13.3	600	22.7	1.32	18.2	105	5.03
	3.4	2.0	4.5	450	17.5	12.3	0.70	1.20	21.6	14.7	450	23.3	1.49	18.0	118	4.59
	3.4	2.0	4.5	600	18.3	13.9	0.76	1.25	22.5	14.7	600	23.9	1.34	19.3	107	5.23
	4.5	3.6	8.3	450	17.9	12.5	0.69	1.15	21.9	15.5	450	23.9	1.50	18.6	119	4.68
85	2.3	1.0	2.2	450	16.4	11.8	0.72	1.35	21.0	12.2	450	23.1	1.49	17.9	118	4.56
	2.3	1.0	2.2	600	17.1	13.3	0.78	1.40	21.9	12.2	600	23.7	1.33	19.1	107	5.20
	3.4	1.9	4.4	450	16.9	12.0	0.71	1.26	21.2	13.5	450	24.3	1.50	19.0	120	4.74
	3.4	1.9	4.4	600	17.6	13.5	0.77	1.31	22.1	13.5	600	24.9	1.35	20.3	108	5.41
	4.5	3.5	8.1	450	17.3	12.2	0.70	1.22	21.5	14.3	450	25.0	1.51	19.6	121	4.84
	4.5	3.5	8.1	600	18.0	13.8	0.76	1.27	22.4	14.3	600	25.6	1.36	20.9	110	5.51
90	2.3	0.9	2.1	450	15.8	11.5	0.73	1.42	20.6	11.1	450	24.1	1.50	18.8	120	4.71
	2.3	0.9	2.1	600	16.4	13.0	0.79	1.48	21.5	11.1	600	24.7	1.35	20.1	108	5.37
	3.4	1.8	4.2	450	16.3	11.7	0.71	1.33	20.8	12.3	450	25.4	1.52	20.0	122	4.89
	3.4	1.8	4.2	600	17.0	13.2	0.78	1.38	21.7	12.3	600	26.0	1.37	21.3	110	5.58
	4.5	3.4	7.9	450	16.7	11.9	0.71	1.28	21.1	13.0	450	26.1	1.53	20.6	124	4.99
100	2.3	0.9	2.0	450	14.4	10.8	0.75	1.57	19.8	9.2	600	26.7	1.38	22.0	111	5.69
	2.3	0.9	2.0	600	15.0	12.2	0.82	1.63	20.6	9.2	Operation Not Recommended					
	3.4	1.7	4.0	450	15.0	11.0	0.74	1.48	20.0	10.1						
	3.4	1.7	4.0	600	15.6	12.5	0.80	1.54	20.8	10.1						
	4.5	3.2	7.4	450	15.4	11.2	0.73	1.43	20.3	10.8						
	4.5	3.2	7.4	600	16.0	12.7	0.79	1.49	21.1	10.8						
110	2.3	0.8	1.8	450	12.9	10.1	0.78	1.74	18.8	7.4						
	2.3	0.8	1.8	600	13.4	11.4	0.85	1.81	19.6	7.4						
	3.4	1.6	3.8	450	13.5	10.3	0.76	1.64	19.1	8.2						
	3.4	1.6	3.8	600	14.0	11.6	0.83	1.71	19.9	8.2						
	4.5	3.1	7.1	450	13.9	10.5	0.75	1.59	19.4	8.8						
120	2.3	0.7	1.7	450	11.2	9.2	0.82	1.92	17.8	5.8	Operation Not Recommended					
	2.3	0.7	1.7	600	11.6	10.4	0.89	2.00	18.5	5.8						
	3.4	1.6	3.6	450	11.8	9.5	0.80	1.82	18.1	6.5						
	3.4	1.6	3.6	600	12.3	10.7	0.87	1.89	18.8	6.5						
	4.5	2.9	6.8	450	12.3	9.7	0.79	1.77	18.4	7.0						
	4.5	2.9	6.8	600	12.8	11.0	0.86	1.84	19.1	7.0						

NOTE: See Legend and Notes on page 25.



50PCH,PCV024 — 800 CFM NOMINAL AIRFLOW

EWT (F)	GPM	WPD		COOLING - EWT 80/67 F							HEATING - EAT 70 F					
		PSI	ft wg	Airflow CFM	TC	SC	Sensible/ Total Ratio	kW	HR	EER	Airflow CFM	HC	kW	HE	LAT	COP
20	6.0	8.5	19.6	Operation Not Recommended							640	15.5	1.91	9.5	92	2.39
	6.0	8.5	19.6	Operation Not Recommended							850	15.9	1.71	10.1	87	2.72
30	3.0	2.2	5.2	640	27.7	17.4	0.63	1.12	31.5	24.8	640	17.2	1.93	11.0	95	2.61
	3.0	2.2	5.2	850	28.9	19.7	0.68	1.16	32.8	24.8	850	17.6	1.74	11.8	89	2.98
	4.5	4.0	9.3	640	28.2	17.5	0.62	1.05	31.8	26.9	640	18.0	1.95	11.7	96	2.70
	4.5	4.0	9.3	850	29.4	19.8	0.67	1.09	33.1	26.9	850	18.4	1.75	12.5	90	3.08
	6.0	7.2	16.7	640	28.5	17.5	0.62	1.02	31.9	28.0	640	18.4	1.95	12.1	97	2.76
	6.0	7.2	16.7	850	29.6	19.8	0.67	1.06	33.2	28.0	850	18.8	1.76	12.9	91	3.14
40	3.0	1.9	4.4	640	26.9	17.1	0.64	1.23	31.1	21.9	640	19.9	1.98	13.4	99	2.94
	3.0	1.9	4.4	850	28.0	19.4	0.69	1.28	32.4	21.9	850	20.4	1.78	14.4	92	3.36
	4.5	3.6	8.2	640	27.5	17.3	0.63	1.15	31.4	24.0	640	20.8	2.00	14.3	100	3.06
	4.5	3.6	8.2	850	28.7	19.6	0.68	1.19	32.7	24.0	850	21.3	1.79	15.3	93	3.49
	6.0	6.4	14.9	640	27.8	17.4	0.63	1.11	31.5	25.1	640	21.3	2.01	14.7	101	3.12
50	3.0	1.7	3.9	640	26.2	16.9	0.65	1.36	30.8	19.3	640	22.6	2.03	15.9	103	3.27
	3.0	1.7	3.9	850	27.3	19.1	0.70	1.42	32.1	19.3	850	23.2	1.82	17.0	95	3.72
	4.5	3.2	7.4	640	26.7	17.0	0.64	1.26	31.0	21.1	640	23.7	2.05	16.9	104	3.39
	4.5	3.2	7.4	850	27.8	19.3	0.69	1.32	32.2	21.1	850	24.3	1.84	18.0	96	3.87
	6.0	5.9	13.6	640	27.0	17.1	0.64	1.22	31.1	22.1	640	24.3	2.06	17.4	105	3.46
	6.0	5.9	13.6	850	28.1	19.4	0.69	1.27	32.4	22.1	850	24.9	1.85	18.6	97	3.94
60	3.0	1.5	3.5	640	25.3	16.6	0.66	1.52	30.4	16.7	640	25.3	2.08	18.3	107	3.57
	3.0	1.5	3.5	850	26.3	18.8	0.71	1.58	31.7	16.7	850	25.9	1.87	19.6	98	4.07
	4.5	3.0	6.9	640	25.7	16.7	0.65	1.40	30.5	18.3	640	26.6	2.10	19.4	108	3.70
	4.5	3.0	6.9	850	26.8	18.9	0.70	1.46	31.7	18.3	850	27.2	1.89	20.7	100	4.22
	6.0	5.5	12.6	640	26.1	16.8	0.64	1.35	30.6	19.3	640	27.2	2.12	20.0	109	3.77
70	3.0	1.4	3.2	640	24.1	16.2	0.67	1.70	29.9	14.2	640	27.9	2.13	20.7	110	3.84
	3.0	1.4	3.2	850	25.1	18.3	0.73	1.77	31.1	14.2	850	28.6	1.91	22.1	101	4.38
	4.5	2.8	6.4	640	24.6	16.3	0.66	1.57	30.0	15.7	640	29.2	2.16	21.8	112	3.97
	4.5	2.8	6.4	850	25.6	18.4	0.72	1.63	31.2	15.7	850	29.9	1.94	23.3	103	4.53
	6.0	5.2	11.9	640	25.0	16.4	0.66	1.51	30.1	16.6	640	29.9	2.17	22.5	113	4.04
	6.0	5.2	11.9	850	26.0	18.6	0.71	1.57	31.4	16.6	850	30.6	1.95	24.0	103	4.60
80	3.0	1.3	3.0	640	22.9	15.7	0.69	1.91	29.4	12.0	640	30.4	2.18	22.9	114	4.08
	3.0	1.3	3.0	850	23.8	17.8	0.75	1.99	30.6	12.0	850	31.1	1.96	24.4	104	4.65
	4.5	2.6	6.1	640	23.4	15.8	0.67	1.76	29.4	13.3	640	31.7	2.21	24.0	116	4.20
	4.5	2.6	6.1	850	24.4	17.9	0.73	1.84	30.7	13.3	850	32.5	1.99	25.7	105	4.79
	6.0	4.9	11.3	640	23.8	16.0	0.67	1.70	29.6	14.1	640	32.4	2.23	24.6	117	4.26
85	3.0	1.3	2.9	640	22.2	15.5	0.70	2.03	29.2	11.0	640	31.5	2.21	23.8	116	4.18
	3.0	1.3	2.9	850	23.1	17.5	0.76	2.12	30.4	11.0	850	32.3	1.98	25.5	105	4.77
	4.5	2.6	5.9	640	22.8	15.6	0.68	1.88	29.2	12.2	640	32.7	2.24	25.0	117	4.29
	4.5	2.6	5.9	850	23.7	17.6	0.74	1.95	30.4	12.2	850	33.5	2.01	26.7	107	4.89
	6.0	4.8	11.0	640	23.2	15.7	0.68	1.80	29.3	12.9	640	33.4	2.25	25.5	118	4.34
	6.0	4.8	11.0	850	24.1	17.8	0.74	1.88	30.5	12.9	850	34.2	2.02	27.2	107	4.95
90	3.0	1.2	2.8	640	21.6	15.3	0.71	2.16	28.9	10.0	640	32.6	2.23	24.8	117	4.28
	3.0	1.2	2.8	850	22.4	17.3	0.77	2.25	30.1	10.0	850	33.4	2.01	26.5	106	4.88
	4.5	2.5	5.8	640	22.2	15.4	0.69	1.99	29.0	11.1	640	33.8	2.26	25.9	119	4.38
	4.5	2.5	5.8	850	23.1	17.4	0.75	2.07	30.1	11.1	850	34.6	2.03	27.6	108	4.99
	6.0	4.7	10.7	640	22.5	15.4	0.69	1.91	29.0	11.8	640	34.4	2.28	26.4	120	4.42
100	3.0	1.2	2.7	640	20.2	14.8	0.74	2.44	28.5	8.3	640	35.2	2.05	28.2	108	5.04
	3.0	1.2	2.7	850	21.0	16.8	0.80	2.54	29.7	8.3	850					
	4.5	2.4	5.5	640	20.8	14.9	0.72	2.25	28.5	9.2	640					
	4.5	2.4	5.5	850	21.6	16.9	0.78	2.34	29.7	9.2	850					
	6.0	4.5	10.3	640	21.1	15.0	0.71	2.16	28.5	9.8	640					
	6.0	4.5	10.3	850	22.0	17.0	0.77	2.25	29.7	9.8	850					
110	3.0	1.1	2.5	640	18.8	14.4	0.77	2.77	28.3	6.8	Operation Not Recommended					
	3.0	1.1	2.5	850	19.5	16.3	0.84	2.88	29.4	6.8						
	4.5	2.3	5.3	640	19.3	14.4	0.75	2.55	28.1	7.6						
	4.5	2.3	5.3	850	20.1	16.3	0.81	2.66	29.2	7.6						
	6.0	4.3	9.9	640	19.7	14.5	0.74	2.45	28.1	8.0						
120	3.0	1.0	2.4	640	17.1	13.9	0.81	3.13	27.9	5.5	Operation Not Recommended					
	3.0	1.0	2.4	850	17.8	15.7	0.88	3.26	29.0	5.5						
	4.5	2.2	5.1	640	17.8	14.0	0.78	2.89	27.8	6.2						
	4.5	2.2	5.1	850	18.6	15.8	0.85	3.01	28.9	6.2						
	6.0	4.2	9.6	640	18.3	14.1	0.77	2.78	27.9	6.6						
	6.0	4.2	9.6	850	19.1	16.0	0.84	2.89	29.0	6.6						

NOTE: See Legend and Notes on page 25.

# Performance data (cont)



## 50PCH,PCV030 — 1000 CFM NOMINAL AIRFLOW

EWT (F)	GPM	WPD		COOLING - EWT 80/67 F							HEATING - EAT 70 F					
		PSI	ft wg	Airflow CFM	TC	SC	Sensible/Total Ratio	kW	HR	EER	Airflow CFM	HC	kW	HE	LAT	COP
20	7.5	5.0	11.6	Operation Not Recommended							750	20.0	2.31	12.6	95	2.53
	7.5	5.0	11.6	Operation Not Recommended							1000	20.4	2.08	13.4	89	2.89
30	3.8	1.3	2.9	750	33.3	20.3	0.61	1.38	38.0	24.0	750	21.6	2.37	14.0	97	2.67
	3.8	1.3	2.9	1000	34.7	22.9	0.66	1.44	39.5	24.0	1000	22.1	2.13	14.9	90	3.04
	5.6	2.3	5.4	750	33.5	20.2	0.60	1.31	37.9	25.7	750	22.5	2.40	14.7	98	2.75
	5.6	2.3	5.4	1000	34.9	22.8	0.65	1.36	39.5	25.7	1000	23.0	2.15	15.7	91	3.13
	7.5	4.2	9.7	750	33.6	20.0	0.60	1.27	37.9	26.5	750	22.9	2.41	15.1	98	2.79
	7.5	4.2	9.7	1000	35.0	22.7	0.65	1.32	39.4	26.5	1000	23.5	2.16	16.2	92	3.18
40	3.8	1.0	2.4	750	32.6	20.2	0.62	1.51	37.7	21.6	750	24.7	2.45	16.7	100	2.95
	3.8	1.0	2.4	1000	34.0	22.8	0.67	1.57	39.3	21.6	1000	25.3	2.20	17.8	93	3.36
	5.6	2.0	4.7	750	33.1	20.3	0.61	1.42	37.9	23.3	750	25.7	2.48	17.6	102	3.04
	5.6	2.0	4.7	1000	34.5	22.9	0.67	1.48	39.5	23.3	1000	26.4	2.23	18.8	94	3.47
	7.5	3.7	8.6	750	33.7	20.5	0.61	1.38	38.3	24.4	750	26.3	2.49	18.1	102	3.10
	7.5	3.7	8.6	1000	35.1	23.2	0.66	1.44	39.9	24.4	1000	26.9	2.24	19.4	95	3.53
50	3.8	0.9	2.1	750	31.6	19.9	0.63	1.65	37.2	19.2	750	27.8	2.52	19.5	104	3.24
	3.8	0.9	2.1	1000	32.9	22.5	0.68	1.72	38.8	19.2	1000	28.5	2.26	20.8	96	3.69
	5.6	1.8	4.2	750	32.3	20.1	0.62	1.55	37.6	20.9	750	29.1	2.55	20.6	106	3.35
	5.6	1.8	4.2	1000	33.7	22.8	0.68	1.61	39.1	20.9	1000	29.8	2.29	22.0	98	3.82
	7.5	3.4	7.8	750	32.6	20.2	0.62	1.50	37.7	21.7	750	29.8	2.56	21.3	107	3.41
	7.5	3.4	7.8	1000	34.0	22.9	0.67	1.57	39.3	21.7	1000	30.5	2.30	22.7	98	3.89
60	3.8	0.8	1.8	750	30.4	19.4	0.64	1.81	36.6	16.8	750	31.0	2.58	22.4	108	3.52
	3.8	0.8	1.8	1000	31.7	21.9	0.69	1.89	38.1	16.8	1000	31.8	2.32	23.9	99	4.02
	5.6	1.7	3.8	750	31.1	19.6	0.63	1.70	36.9	18.3	750	32.5	2.61	23.7	110	3.65
	5.6	1.7	3.8	1000	32.4	22.2	0.69	1.77	38.4	18.3	1000	33.3	2.34	25.3	101	4.16
	7.5	3.1	7.2	750	31.4	19.7	0.63	1.65	37.0	19.0	750	33.3	2.63	24.4	111	3.71
	7.5	3.1	7.2	1000	32.7	22.3	0.68	1.71	38.5	19.1	1000	34.1	2.36	26.0	102	4.24
70	3.8	0.7	1.6	750	29.0	18.8	0.65	2.00	35.8	14.5	750	34.2	2.64	25.2	112	3.79
	3.8	0.7	1.6	1000	30.2	21.2	0.70	2.08	37.3	14.5	1000	35.1	2.37	26.9	102	4.33
	5.6	1.5	3.6	750	30.0	19.2	0.64	1.87	36.3	16.0	750	35.8	2.68	26.7	114	3.92
	5.6	1.5	3.6	1000	31.2	21.7	0.70	1.95	37.8	16.0	1000	36.7	2.40	28.5	104	4.47
	7.5	2.9	6.7	750	30.4	19.4	0.64	1.81	36.6	16.8	750	36.7	2.70	27.4	115	3.99
	7.5	2.9	6.7	1000	31.7	21.9	0.69	1.89	38.1	16.8	1000	37.6	2.42	29.3	105	4.55
80	3.8	0.7	1.5	750	27.7	18.3	0.66	2.21	35.3	12.5	750	37.3	2.71	28.0	116	4.04
	3.8	0.7	1.5	1000	28.8	20.7	0.72	2.30	36.7	12.5	1000	38.2	2.43	29.9	105	4.60
	5.6	1.4	3.3	750	28.5	18.5	0.65	2.07	35.5	13.7	750	39.0	2.75	29.5	118	4.15
	5.6	1.4	3.3	1000	29.6	21.0	0.71	2.16	37.0	13.7	1000	40.0	2.47	31.5	107	4.74
	7.5	2.7	6.3	750	29.0	18.7	0.65	2.00	35.8	14.5	750	40.2	2.78	30.6	120	4.24
	7.5	2.7	6.3	1000	30.2	21.2	0.70	2.08	37.3	14.5	1000	41.2	2.50	32.6	108	4.84
85	3.8	0.6	1.4	750	26.7	17.8	0.67	2.34	34.7	11.5	750	38.8	2.75	29.3	118	4.14
	3.8	0.6	1.4	1000	27.8	20.1	0.72	2.43	36.1	11.5	1000	39.8	2.5	31.3	107	4.72
	5.6	1.4	3.2	750	27.6	18.2	0.66	2.18	35.1	12.7	750	40.5	2.8	30.8	120	4.24
	5.6	1.4	3.2	1000	28.8	20.6	0.71	2.27	36.5	12.7	1000	41.5	2.5	32.9	108	4.84
	7.5	2.7	6.2	750	28.2	18.4	0.65	2.11	35.4	13.4	750	41.6	2.8	31.7	121	4.30
	7.5	2.7	6.2	1000	29.3	20.8	0.71	2.20	36.8	13.4	1000	42.6	2.5	33.9	109	4.91
90	3.8	0.6	1.4	750	25.7	17.3	0.67	2.46	34.1	10.5	750	40.3	2.79	30.6	120	4.23
	3.8	0.6	1.4	1000	26.8	19.6	0.73	2.56	35.5	10.5	1000	41.3	2.51	32.7	108	4.83
	5.6	1.4	3.1	750	26.8	17.8	0.66	2.30	34.7	11.7	750	42.0	2.85	32.1	122	4.33
	5.6	1.4	3.1	1000	27.9	20.1	0.72	2.39	36.1	11.7	1000	43.0	2.56	34.3	110	4.93
	7.5	2.6	6.0	750	27.3	18.0	0.66	2.22	34.9	12.3	750	42.9	2.88	32.9	123	4.36
	7.5	2.6	6.0	1000	28.5	20.4	0.72	2.31	36.4	12.3	1000	44.0	2.59	35.1	111	4.98
100	3.8	0.6	1.3	750	24.0	16.6	0.69	2.74	33.3	8.7	Operation Not Recommended					
	3.8	0.6	1.3	1000	24.9	18.8	0.75	2.85	34.7	8.7						
	5.6	1.3	3.0	750	25.1	17.0	0.68	2.56	33.8	9.8						
	5.6	1.3	3.0	1000	26.1	19.3	0.74	2.67	35.2	9.8						
	7.5	2.5	5.7	750	25.6	17.3	0.67	2.48	34.1	10.3						
	7.5	2.5	5.7	1000	26.7	19.6	0.73	2.58	35.5	10.3						
110	3.8	0.5	1.2	750	22.5	16.1	0.72	3.07	33.0	7.4	Operation Not Recommended					
	3.8	0.5	1.2	1000	23.5	18.2	0.78	3.19	34.4	7.4						
	5.6	1.2	2.8	750	23.2	16.3	0.70	2.86	33.1	8.1						
	5.6	1.2	2.8	1000	24.2	18.4	0.76	2.98	34.4	8.1						
	7.5	2.4	5.5	750	23.8	16.5	0.69	2.77	33.3	8.6						
	7.5	2.4	5.5	1000	24.8	18.7	0.75	2.88	34.6	8.6						
120	3.8	0.5	1.1	750	20.4	15.2	0.74	3.44	32.2	5.9	Operation Not Recommended					
	3.8	0.5	1.1	1000	21.2	17.2	0.81	3.58	33.5	5.9						
	5.6	1.2	2.7	750	21.4	15.6	0.73	3.21	32.4	6.7						
	5.6	1.2	2.7	1000	22.3	17.6	0.79	3.34	33.8	6.7						
	7.5	2.3	5.3	750	22.0	15.8	0.72	3.10	32.6	7.1						
	7.5	2.3	5.3	1000	22.9	17.8	0.78	3.23	33.9	7.1						

NOTE: See Legend and Notes on page 25.



### 50PCH,PCV036 – 1200 CFM NOMINAL AIRFLOW

EWT (F)	GPM	WPD		COOLING - EWT 80/67 F							HEATING - EAT 70 F					
		PSI	ft wg	Airflow CFM	TC	SC	Sensible/ Total Ratio	kW	HR	EER	Airflow CFM	HC	kW	HE	LAT	COP
20	9.0	6.4	14.8	Operation Not Recommended							860	22.6	2.67	14.1	94	2.49
	9.0	6.4	14.8	Operation Not Recommended							1150	23.2	2.39	15.1	89	2.84
30	4.5	1.8	4.3	860	39.9	24.2	0.61	1.67	45.6	23.8	860	25.6	2.80	16.6	98	2.68
	4.5	1.8	4.3	1150	41.5	27.4	0.66	1.74	47.4	23.8	1150	26.2	2.51	17.7	91	3.06
	6.8	3.1	7.1	860	40.1	24.3	0.61	1.62	45.5	24.7	860	26.8	2.85	17.6	99	2.76
	6.8	3.1	7.1	1150	41.7	27.5	0.66	1.69	47.4	24.7	1150	27.5	2.56	18.8	92	3.15
	9.0	5.4	12.5	860	40.0	24.3	0.61	1.60	45.5	25.0	860	27.5	2.88	18.2	100	2.80
	9.0	5.4	12.5	1150	41.7	27.5	0.66	1.67	47.3	25.0	1150	28.2	2.59	19.4	93	3.19
40	4.5	1.6	3.6	860	39.2	24.0	0.61	1.80	45.3	21.8	860	30.1	2.98	20.3	102	2.95
	4.5	1.6	3.6	1150	40.8	27.2	0.67	1.87	47.1	21.8	1150	30.8	2.68	21.7	95	3.37
	6.8	2.7	6.2	860	39.7	24.2	0.61	1.71	45.5	23.3	860	31.6	3.05	21.6	104	3.04
	6.8	2.7	6.2	1150	41.4	27.4	0.66	1.78	47.4	23.3	1150	32.4	2.74	23.1	96	3.47
	9.0	4.8	11.1	860	39.9	24.3	0.61	1.67	45.6	23.9	860	32.4	3.08	22.3	105	3.09
	9.0	4.8	11.1	1150	41.6	27.4	0.66	1.74	47.4	23.9	1150	33.2	2.77	23.8	97	3.52
50	4.5	1.4	3.2	860	38.0	23.6	0.62	1.98	44.7	19.2	860	34.5	3.16	24.1	107	3.20
	4.5	1.4	3.2	1150	39.5	26.7	0.68	2.06	46.5	19.2	1150	35.4	2.84	25.7	98	3.65
	6.8	2.4	5.6	860	38.8	23.9	0.62	1.85	45.1	21.0	860	36.3	3.23	25.6	109	3.30
	6.8	2.4	5.6	1150	40.4	27.0	0.67	1.92	47.0	21.0	1150	37.2	2.90	27.3	100	3.76
	9.0	4.4	10.1	860	39.2	24.0	0.61	1.79	45.3	21.9	860	37.3	3.27	26.4	110	3.35
	9.0	4.4	10.1	1150	40.8	27.2	0.67	1.87	47.2	21.9	1150	38.2	2.93	28.2	101	3.82
60	4.5	1.3	2.9	860	36.1	22.9	0.63	2.20	43.6	16.4	860	38.9	3.32	27.8	112	3.43
	4.5	1.3	2.9	1150	37.6	25.9	0.69	2.29	45.4	16.4	1150	39.8	2.99	29.7	102	3.91
	6.8	2.3	5.2	860	37.5	23.5	0.63	2.04	44.4	18.4	860	40.9	3.40	29.5	114	3.53
	6.8	2.3	5.2	1150	39.1	26.5	0.68	2.13	46.3	18.4	1150	41.9	3.05	31.5	104	4.02
	9.0	4.0	9.3	860	38.0	23.6	0.62	1.97	44.7	19.3	860	42.0	3.44	30.4	115	3.58
	9.0	4.0	9.3	1150	39.6	26.7	0.68	2.05	46.5	19.3	1150	43.0	3.09	32.5	105	4.08
70	4.5	1.2	2.7	860	34.6	22.5	0.65	2.46	42.9	14.0	860	43.1	3.47	31.4	116	3.64
	4.5	1.2	2.7	1150	36.0	25.5	0.71	2.56	44.7	14.0	1150	44.1	3.12	33.5	106	4.15
	6.8	2.1	4.9	860	35.8	22.9	0.64	2.28	43.6	15.7	860	45.2	3.55	33.2	119	3.74
	6.8	2.1	4.9	1150	37.3	25.9	0.70	2.38	45.4	15.7	1150	46.3	3.19	35.4	107	4.26
	9.0	3.8	8.7	860	36.4	23.1	0.63	2.20	43.9	16.6	860	46.4	3.59	34.2	120	3.79
	9.0	3.8	8.7	1150	37.9	26.1	0.69	2.29	45.7	16.6	1150	47.5	3.22	36.5	108	4.32
80	4.5	1.1	2.5	860	32.5	21.8	0.67	2.76	41.9	11.8	860	47.0	3.61	34.8	121	3.82
	4.5	1.1	2.5	1150	33.8	24.7	0.73	2.88	43.7	11.8	1150	48.2	3.24	37.1	109	4.36
	6.8	2.0	4.6	860	33.9	22.3	0.66	2.56	42.6	13.2	860	49.2	3.68	36.6	123	3.92
	6.8	2.0	4.6	1150	35.3	25.2	0.72	2.67	44.4	13.2	1150	50.4	3.30	39.1	111	4.47
	9.0	3.6	8.3	860	34.5	22.5	0.65	2.47	42.9	14.0	860	50.3	3.71	37.6	124	3.97
	9.0	3.6	8.3	1150	35.9	25.5	0.71	2.57	44.7	14.0	1150	51.5	3.34	40.1	111	4.53
85	4.5	1.0	2.4	860	31.5	21.5	0.68	2.9	41.5	10.8	860	48.8	3.67	36.3	123	3.90
	4.5	1.0	2.4	1150	32.8	24.4	0.74	3.05	43.3	10.8	1150	50.0	3.29	38.8	110	4.45
	6.8	1.9	4.4	860	32.8	21.9	0.67	2.72	42.1	12.1	860	50.9	3.73	38.1	125	4.00
	6.8	1.9	4.4	1150	34.1	24.8	0.73	2.84	43.8	12.1	1150	52.2	3.35	40.7	112	4.56
	9.0	3.5	8.1	860	33.4	22.1	0.66	2.62	42.3	12.8	860	52.0	3.76	39.0	126	4.05
	9.0	3.5	8.1	1150	34.7	25.0	0.72	2.73	44.1	12.8	1150	53.2	3.38	41.7	113	4.62
90	4.5	1.0	2.3	860	30.5	21.2	0.70	3.10	41.1	9.8	860	50.6	3.72	37.9	125	3.99
	4.5	1.0	2.3	1150	31.8	24.0	0.76	3.23	42.8	9.8	1150	51.9	3.34	40.4	112	4.54
	6.8	1.9	4.3	860	31.7	21.6	0.68	2.88	41.6	11.0	860	52.7	3.79	39.6	127	4.08
	6.8	1.9	4.3	1150	33.0	24.4	0.74	3.00	43.3	11.0	1150	54.0	3.40	42.3	113	4.65
	9.0	3.4	7.9	860	32.2	21.7	0.67	2.78	41.7	11.6	860	53.7	3.82	40.5	128	4.12
	9.0	3.4	7.9	1150	33.5	24.5	0.73	2.89	43.4	11.6	1150	55.0	3.43	43.2	114	4.70
100	4.5	0.9	2.2	860	28.3	20.5	0.72	3.47	40.2	8.1	Operation Not Recommended					
	4.5	0.9	2.2	1150	29.5	23.1	0.79	3.62	41.9	8.2						
	6.8	1.8	4.1	860	29.5	20.8	0.71	3.24	40.6	9.1						
	6.8	1.8	4.1	1150	30.7	23.5	0.77	3.37	42.2	9.1						
	9.0	3.3	7.5	860	30.1	21.0	0.70	3.13	40.8	9.6						
	9.0	3.3	7.5	1150	31.3	23.7	0.76	3.25	42.5	9.6						
110	4.5	0.9	2.1	860	26.2	19.8	0.75	3.88	39.5	6.8						
	4.5	0.9	2.1	1150	27.3	22.4	0.82	4.04	41.1	6.8						
	6.8	1.7	4.0	860	27.2	20.0	0.73	3.63	39.7	7.5						
	6.8	1.7	4.0	1150	28.4	22.6	0.80	3.78	41.3	7.5						
	9.0	3.1	7.2	860	27.6	20.0	0.72	3.51	39.6	7.9						
	9.0	3.1	7.2	1150	28.8	22.7	0.79	3.65	41.3	7.9						
120	4.5	0.9	2.0	860	24.1	19.0	0.79	4.31	38.9	5.6						
	4.5	0.9	2.0	1150	25.1	21.4	0.86	4.49	40.4	5.6						
	6.8	1.6	3.8	860	25.1	19.2	0.77	4.05	39.0	6.2						
	6.8	1.6	3.8	1150	26.1	21.8	0.83	4.21	40.6	6.2						
	9.0	3.0	7.0	860	25.4	19.2	0.76	3.92	38.9	6.5						
	9.0	3.0	7.0	1150	26.5	21.8	0.82	4.08	40.5	6.5						

NOTE: See Legend and Notes on page 25.

# Performance data (cont)



## 50PCH,PCV042 — 1350 CFM NOMINAL AIRFLOW

EWT (F)	GPM	WPD		COOLING - EWT 80/67 F							HEATING - EAT 70 F					
		PSI	ft wg	Airflow CFM	TC	SC	Sensible/ Total Ratio	kW	HR	EER	Airflow CFM	HC	kW	HE	LAT	COP
20	10.5	9.2	21.3	Operation Not Recommended							1050	28.8	3.37	18.1	95	2.51
	10.5	9.2	21.3	Operation Not Recommended							1400	29.5	3.03	19.3	90	2.86
30	5.3	2.3	5.3	1050	47.4	30.6	0.65	1.87	53.7	25.4	1050	31.6	3.45	20.5	98	2.68
	5.3	2.3	5.3	1400	49.3	34.7	0.70	1.95	55.9	25.4	1400	32.4	3.10	21.9	91	3.06
	7.9	4.3	10.0	1050	48.4	31.1	0.64	1.76	54.4	27.5	1050	32.9	3.49	21.6	99	2.76
	7.9	4.3	10.0	1400	50.4	35.2	0.70	1.83	56.6	27.5	1400	33.7	3.14	23.1	92	3.15
	10.5	7.9	18.2	1050	48.9	31.3	0.64	1.71	54.7	28.6	1050	33.6	3.52	22.3	100	2.80
	10.5	7.9	18.2	1400	50.9	35.5	0.70	1.78	57.0	28.6	1400	34.5	3.16	23.8	93	3.20
40	5.3	2.0	4.6	1050	45.9	29.9	0.65	2.05	52.8	22.4	1050	36.1	3.59	24.4	102	2.95
	5.3	2.0	4.6	1400	47.8	33.9	0.71	2.13	55.0	22.4	1400	37.0	3.23	26.1	94	3.36
	7.9	3.9	8.9	1050	47.0	30.4	0.65	1.92	53.4	24.5	1050	37.8	3.64	25.8	103	3.04
	7.9	3.9	8.9	1400	48.9	34.4	0.70	2.00	55.6	24.5	1400	38.7	3.27	27.6	96	3.46
	10.5	7.1	16.4	1050	47.5	30.7	0.65	1.86	53.8	25.5	1050	38.7	3.67	26.6	104	3.09
	10.5	7.1	16.4	1400	49.4	34.7	0.70	1.94	56.0	25.5	1400	39.6	3.30	28.4	96	3.52
50	5.3	1.8	4.1	1050	44.4	29.2	0.66	2.26	52.0	19.6	1050	40.8	3.74	28.5	106	3.20
	5.3	1.8	4.1	1400	46.2	33.1	0.72	2.35	54.2	19.6	1400	41.8	3.36	30.4	98	3.65
	7.9	3.5	8.1	1050	45.4	29.7	0.65	2.11	52.6	21.5	1050	42.8	3.80	30.2	108	3.30
	7.9	3.5	8.1	1400	47.3	33.6	0.71	2.20	54.8	21.5	1400	43.8	3.41	32.2	99	3.76
	10.5	6.5	15.0	1050	46.0	30.0	0.65	2.04	52.9	22.5	1050	43.9	3.83	31.1	109	3.35
	10.5	6.5	15.0	1400	47.9	33.9	0.71	2.12	55.1	22.5	1400	44.9	3.44	33.2	100	3.82
60	5.3	1.6	3.7	1050	43.1	28.8	0.67	2.51	51.7	17.2	1050	45.6	3.89	32.6	110	3.44
	5.3	1.6	3.7	1400	44.9	32.6	0.73	2.61	53.8	17.2	1400	46.7	3.49	34.8	101	3.92
	7.9	3.3	7.5	1050	43.9	29.0	0.66	2.34	51.8	18.8	1050	47.8	3.96	34.5	112	3.54
	7.9	3.3	7.5	1400	45.7	32.8	0.72	2.43	53.9	18.8	1400	49.0	3.56	36.9	102	4.04
	10.5	6.1	14.0	1050	44.4	29.2	0.66	2.25	52.1	19.7	1050	49.0	4.00	35.6	113	3.60
	10.5	6.1	14.0	1400	46.2	33.1	0.72	2.35	54.2	19.7	1400	50.2	3.59	38.0	103	4.10
70	5.3	1.5	3.4	1050	41.3	28.1	0.68	2.80	50.9	14.8	1050	50.3	4.04	36.7	114	3.65
	5.3	1.5	3.4	1400	43.0	31.8	0.74	2.91	52.9	14.8	1400	51.5	3.63	39.2	104	4.16
	7.9	3.1	7.1	1050	42.2	28.3	0.67	2.60	51.0	16.2	1050	52.8	4.11	38.8	117	3.76
	7.9	3.1	7.1	1400	43.9	32.0	0.73	2.71	53.1	16.2	1400	54.1	3.70	41.5	106	4.29
	10.5	5.7	13.2	1050	42.8	28.5	0.67	2.51	51.3	17.1	1050	54.1	4.16	40.0	118	3.82
	10.5	5.7	13.2	1400	44.5	32.3	0.73	2.61	53.4	17.1	1400	55.4	3.73	42.7	107	4.35
80	5.3	1.4	3.2	1050	39.5	27.4	0.70	3.13	50.1	12.6	1050	54.9	4.18	40.7	118	3.85
	5.3	1.4	3.2	1400	41.1	31.0	0.76	3.26	52.2	12.6	1400	56.3	3.76	43.4	107	4.39
	7.9	2.9	6.7	1050	40.4	27.6	0.68	2.91	50.3	13.9	1050	57.6	4.27	43.0	121	3.96
	7.9	2.9	6.7	1400	42.1	31.3	0.74	3.03	52.4	13.9	1400	59.0	3.83	45.9	109	4.51
	10.5	5.4	12.6	1050	41.0	27.9	0.68	2.80	50.6	14.6	1050	59.0	4.31	44.2	122	4.01
	10.5	5.4	12.6	1400	42.7	31.5	0.74	2.92	52.6	14.6	1400	60.4	3.87	47.2	110	4.58
85	5.3	1.3	3.1	1050	38.4	27.1	0.71	3.32	49.8	11.6	1050	57.2	4.25	42.6	120	3.94
	5.3	1.3	3.1	1400	40.0	30.7	0.77	3.46	51.8	11.6	1400	58.6	3.82	45.5	109	4.49
	7.9	2.8	6.5	1050	39.4	27.3	0.69	3.08	50.0	12.8	1050	59.9	4.34	44.9	123	4.05
	7.9	2.8	6.5	1400	41.1	30.9	0.75	3.21	52.0	12.9	1400	61.3	3.89	48.0	111	4.61
	10.5	5.3	12.3	1050	40.1	27.5	0.69	2.97	50.2	13.5	1050	61.3	4.38	46.2	124	4.10
	10.5	5.3	12.3	1400	41.7	31.2	0.75	3.09	52.3	13.6	1400	62.7	3.93	49.3	111	4.68
90	5.3	1.3	3.0	1050	37.4	26.8	0.72	3.51	49.4	10.7	1050	59.4	4.32	44.6	122	4.03
	5.3	1.3	3.0	1400	39.0	30.3	0.78	3.65	51.5	10.7	1400	60.8	3.88	47.6	110	4.59
	7.9	2.8	6.4	1050	38.5	27.0	0.70	3.26	49.6	11.8	1050	62.1	4.40	46.9	125	4.13
	7.9	2.8	6.4	1400	40.1	30.6	0.76	3.39	51.6	11.8	1400	63.6	3.96	50.1	112	4.71
	10.5	5.2	12.0	1050	39.1	27.2	0.70	3.14	49.8	12.5	1050	63.5	4.45	48.1	126	4.19
	10.5	5.2	12.0	1400	40.7	30.8	0.76	3.27	51.9	12.5	1400	65.1	3.99	51.4	113	4.77
100	5.3	1.2	2.8	1050	35.2	26.2	0.74	3.94	48.7	8.9	Operation Not Recommended					
	5.3	1.2	2.8	1400	36.7	29.6	0.81	4.10	50.7	8.9	Operation Not Recommended					
	7.9	2.7	6.1	1050	36.4	26.4	0.73	3.66	48.9	9.9	Operation Not Recommended					
	7.9	2.7	6.1	1400	37.9	29.9	0.79	3.81	50.9	9.9	Operation Not Recommended					
	10.5	5.0	11.6	1050	37.1	26.6	0.72	3.52	49.1	10.5	Operation Not Recommended					
	10.5	5.0	11.6	1400	38.6	30.1	0.78	3.67	51.1	10.5	Operation Not Recommended					
110	5.3	1.2	2.7	1050	32.8	25.5	0.78	4.41	47.9	7.4	Operation Not Recommended					
	5.3	1.2	2.7	1400	34.2	28.9	0.85	4.60	49.9	7.4	Operation Not Recommended					
	7.9	2.6	5.9	1050	34.1	25.7	0.76	4.11	48.1	8.3	Operation Not Recommended					
	7.9	2.6	5.9	1400	35.5	29.1	0.82	4.28	50.1	8.3	Operation Not Recommended					
	10.5	4.8	11.2	1050	34.8	25.9	0.75	3.96	48.4	8.8	Operation Not Recommended					
	10.5	4.8	11.2	1400	36.2	29.4	0.81	4.12	50.4	8.8	Operation Not Recommended					
120	5.3	1.1	2.6	1050	30.2	24.8	0.82	4.95	47.1	6.1	Operation Not Recommended					
	5.3	1.1	2.6	1400	31.4	28.0	0.89	5.15	49.1	6.1	Operation Not Recommended					
	7.9	2.5	5.7	1050	31.5	25.0	0.79	4.61	47.3	6.8	Operation Not Recommended					
	7.9	2.5	5.7	1400	32.8	28.3	0.86	4.80	49.3	6.8	Operation Not Recommended					
	10.5	4.7	10.8	1050	32.3	25.3	0.78	4.45	47.6	7.3	Operation Not Recommended					
	10.5	4.7	10.8	1400	33.7	28.6	0.85	4.63	49.5	7.3	Operation Not Recommended					

NOTE: See Legend and Notes on page 25.



### 50PCH,PCV048 — 1600 CFM NOMINAL AIRFLOW

EWT (F)	GPM	WPD		COOLING - EWT 80/67 F							HEATING - EAT 70 F					
		PSI	ft wg	Airflow CFM	TC	SC	Sensible/ Total Ratio	kW	HR	EER	Airflow CFM	HC	kW	HE	LAT	COP
20	12.0	6.8	15.6	Operation Not Recommended							1200	30.9	3.54	19.6	94	2.56
	12.0	6.8	15.6								1600	31.6	3.18	20.9	88	2.92
30	6.0	1.8	4.1	1200	56.4	34.4	0.61	2.25	64.0	25.1	1200	33.9	3.60	22.3	96	2.76
	6.0	1.8	4.1	1600	58.8	39.0	0.66	2.34	66.7	25.1	1600	34.7	3.24	23.8	90	3.14
	9.0	3.4	7.8	1200	57.5	34.6	0.60	2.11	64.6	27.2	1200	34.4	3.63	22.7	97	2.78
	9.0	3.4	7.8	1600	59.8	39.1	0.65	2.20	67.2	27.2	1600	35.3	3.26	24.2	90	3.17
	12.0	6.2	14.3	1200	57.9	34.5	0.60	2.05	64.8	28.2	1200	35.1	3.65	23.3	97	2.82
	12.0	6.2	14.3	1600	60.3	39.1	0.65	2.14	67.5	28.2	1600	36.0	3.27	24.9	91	3.22
40	6.0	1.6	3.7	1200	54.8	34.0	0.62	2.47	63.2	22.2	1200	37.9	3.70	25.8	99	3.00
	6.0	1.6	3.7	1600	57.1	38.5	0.67	2.57	65.8	22.2	1600	38.8	3.33	27.5	92	3.42
	9.0	3.1	7.2	1200	56.0	34.3	0.61	2.31	63.8	24.3	1200	39.5	3.74	27.2	100	3.10
	9.0	3.1	7.2	1600	58.3	38.9	0.67	2.40	66.4	24.3	1600	40.5	3.36	29.1	93	3.53
	12.0	5.8	13.4	1200	56.6	34.5	0.61	2.23	64.1	25.4	1200	40.7	3.76	28.3	101	3.18
50	6.0	1.5	3.4	1200	52.9	33.3	0.63	2.72	62.1	19.4	1200	43.6	3.81	31.0	104	3.36
	6.0	1.5	3.4	1600	55.1	37.7	0.68	2.83	64.7	19.4	1600	44.7	3.42	33.0	96	3.83
	9.0	3.0	6.8	1200	54.3	33.8	0.62	2.53	62.9	21.4	1200	44.9	3.85	32.1	105	3.42
	9.0	3.0	6.8	1600	56.5	38.3	0.68	2.64	65.5	21.4	1600	46.0	3.46	34.3	97	3.90
	12.0	5.5	12.7	1200	55.0	34.0	0.62	2.45	63.2	22.5	1200	46.0	3.87	33.1	106	3.49
	12.0	5.5	12.7	1600	57.2	38.5	0.67	2.55	65.8	22.5	1600	47.1	3.48	35.3	97	3.98
60	6.0	1.4	3.2	1200	50.7	32.5	0.64	3.02	61.0	16.8	1200	48.2	3.91	35.0	107	3.61
	6.0	1.4	3.2	1600	52.8	36.8	0.70	3.15	63.5	16.8	1600	49.3	3.51	37.4	99	4.11
	9.0	2.8	6.5	1200	52.3	33.1	0.63	2.81	61.8	18.6	1200	50.5	3.96	37.1	109	3.74
	9.0	2.8	6.5	1600	54.5	37.5	0.69	2.92	64.4	18.6	1600	51.8	3.56	39.6	100	4.26
	12.0	5.3	12.2	1200	53.0	33.4	0.63	2.70	62.2	19.6	1200	51.8	3.99	38.3	110	3.81
70	6.0	1.3	3.0	1200	48.3	31.5	0.65	3.38	59.9	14.3	1200	53.5	4.02	39.8	111	3.90
	6.0	1.3	3.0	1600	50.3	35.7	0.71	3.52	62.3	14.3	1600	54.8	3.61	42.4	102	4.44
	9.0	2.7	6.3	1200	50.0	32.2	0.64	3.13	60.7	16.0	1200	56.2	4.08	42.2	113	4.03
	9.0	2.7	6.3	1600	52.1	36.4	0.70	3.25	63.2	16.0	1600	57.5	3.67	45.0	103	4.60
	12.0	5.1	11.8	1200	50.9	32.5	0.64	3.01	61.1	16.9	1200	57.6	4.12	43.4	114	4.10
	12.0	5.1	11.8	1600	53.0	36.8	0.70	3.13	63.6	16.9	1600	59.0	3.70	46.4	104	4.68
80	6.0	1.3	2.9	1200	45.7	30.5	0.67	3.79	58.6	12.1	1200	58.8	4.14	44.5	115	4.16
	6.0	1.3	2.9	1600	47.6	34.5	0.72	3.94	61.0	12.1	1600	60.2	3.72	47.5	105	4.74
	9.0	2.6	6.1	1200	47.5	31.2	0.66	3.50	59.5	13.6	1200	61.7	4.21	47.1	118	4.29
	9.0	2.6	6.1	1600	49.5	35.3	0.71	3.64	61.9	13.6	1600	63.2	3.78	50.2	107	4.90
	12.0	4.9	11.4	1200	48.4	31.6	0.65	3.37	59.9	14.4	1200	63.3	4.25	48.4	119	4.36
85	6.0	1.2	2.8	1200	44.3	29.9	0.68	4.02	58.0	11.1	1200	61.3	4.20	46.7	117	4.28
	6.0	1.2	2.8	1600	46.1	33.8	0.73	4.19	60.4	11.1	1600	62.8	3.78	49.9	106	4.88
	9.0	2.6	6.0	1200	46.2	30.6	0.66	3.72	58.8	12.5	1200	64.3	4.28	49.4	120	4.40
	9.0	2.6	6.0	1600	48.1	34.7	0.72	3.87	61.3	12.5	1600	65.9	3.84	52.7	108	5.02
	12.0	4.9	11.3	1200	47.1	31.0	0.66	3.57	59.3	13.2	1200	65.9	4.32	50.7	121	4.47
	12.0	4.9	11.3	1600	49.0	35.1	0.72	3.72	61.7	13.2	1600	67.5	3.88	54.1	109	5.09
90	6.0	1.2	2.8	1200	42.9	29.3	0.68	4.26	57.4	10.1	1200	63.9	4.27	49.0	119	4.39
	6.0	1.2	2.8	1600	44.6	33.2	0.74	4.43	59.8	10.1	1600	65.5	3.83	52.3	108	5.01
	9.0	2.6	5.9	1200	44.8	30.1	0.67	3.93	58.2	11.4	1200	66.9	4.35	51.7	122	4.51
	9.0	2.6	5.9	1600	46.6	34.1	0.73	4.10	60.6	11.4	1600	68.6	3.91	55.1	110	5.14
	12.0	4.8	11.1	1200	45.7	30.5	0.67	3.78	58.6	12.1	1200	68.5	4.39	53.0	123	4.57
100	6.0	1.2	2.7	1200	39.8	28.2	0.71	4.79	56.2	8.3	1600	70.2	3.95	56.6	111	5.21
	6.0	1.2	2.7	1600	41.4	31.9	0.77	4.99	58.5	8.3	1200	70.2	3.95	56.6	111	5.21
	9.0	2.5	5.8	1200	41.8	28.9	0.69	4.43	57.0	9.4	1200	70.2	3.95	56.6	111	5.21
	9.0	2.5	5.8	1600	43.5	32.7	0.75	4.62	59.3	9.4	1600	70.2	3.95	56.6	111	5.21
	12.0	4.7	10.9	1200	42.8	29.3	0.69	4.26	57.4	10.0	1200	70.2	3.95	56.6	111	5.21
	12.0	4.7	10.9	1600	44.6	33.2	0.74	4.44	59.7	10.0	1600	70.2	3.95	56.6	111	5.21
110	6.0	1.1	2.6	1200	36.5	26.9	0.74	5.40	55.0	6.8	1200	70.2	3.95	56.6	111	5.21
	6.0	1.1	2.6	1600	38.0	30.4	0.80	5.62	57.3	6.8	1200	70.2	3.95	56.6	111	5.21
	9.0	2.4	5.6	1200	38.6	27.7	0.72	5.00	55.8	7.7	1200	70.2	3.95	56.6	111	5.21
	9.0	2.4	5.6	1600	40.2	31.4	0.78	5.21	58.0	7.7	1200	70.2	3.95	56.6	111	5.21
	12.0	4.6	10.6	1200	39.7	28.1	0.71	4.81	56.1	8.2	1200	70.2	3.95	56.6	111	5.21
120	6.0	1.1	2.5	1200	33.0	25.5	0.77	6.09	53.9	5.4	1200	70.2	3.95	56.6	111	5.21
	6.0	1.1	2.5	1600	34.4	28.9	0.84	6.34	56.1	5.4	1200	70.2	3.95	56.6	111	5.21
	9.0	2.4	5.5	1200	35.2	26.4	0.75	5.65	54.6	6.2	1200	70.2	3.95	56.6	111	5.21
	9.0	2.4	5.5	1600	36.7	29.9	0.81	5.88	56.8	6.2	1200	70.2	3.95	56.6	111	5.21
	12.0	4.5	10.4	1200	36.3	26.8	0.74	5.44	55.0	6.7	1200	70.2	3.95	56.6	111	5.21
12.0	4.5	10.4	1600	37.8	30.3	0.80	5.66	57.2	6.7	1200	70.2	3.95	56.6	111	5.21	

NOTE: See Legend and Notes on page 25.

# Performance data (cont)



## 50PCH,PCV060 — 2000 CFM NOMINAL AIRFLOW

EWT (F)	GPM	WPD		COOLING - EWT 80/67 F							HEATING - EAT 70 F					
		PSI	ft wg	Airflow CFM	TC	SC	Sensible/Total Ratio	kW	HR	EER	Airflow CFM	HC	kW	HE	LAT	COP
20	15.0	14.0	32.2	Operation Not Recommended							1460	41.6	4.98	25.8	96	2.45
	15.0	14.0	32.2	Operation Not Recommended							1950	42.6	4.48	27.5	90	2.79
30	7.5	3.4	7.9	1460	68.2	41.6	0.61	3.00	78.3	22.8	1460	45.5	5.08	29.2	99	2.62
	7.5	3.4	7.9	1950	71.0	47.0	0.66	3.12	81.6	22.8	1950	46.6	4.56	31.1	92	2.99
	11.3	6.8	15.8	1460	69.0	41.5	0.60	2.87	78.7	24.0	1460	47.4	5.13	30.9	100	2.71
	11.3	6.8	15.8	1950	71.8	47.0	0.65	2.99	82.0	24.0	1950	48.6	4.61	33.0	93	3.09
	15.0	12.6	29.2	1460	69.3	41.3	0.60	2.82	78.8	24.6	1460	48.5	5.16	31.8	101	2.75
	15.0	12.6	29.2	1950	72.1	46.8	0.65	2.94	82.1	24.6	1950	49.7	4.64	34.0	94	3.14
40	7.5	3.1	7.0	1460	66.6	41.1	0.62	3.21	77.4	20.8	1460	52.2	5.27	35.1	103	2.91
	7.5	3.1	7.0	1950	69.3	46.5	0.67	3.34	80.6	20.8	1950	53.5	4.73	37.5	95	3.31
	11.3	6.3	14.6	1460	67.8	41.5	0.61	3.05	78.1	22.2	1460	54.8	5.34	37.3	105	3.01
	11.3	6.3	14.6	1950	70.6	47.0	0.67	3.18	81.3	22.2	1950	56.1	4.80	39.8	97	3.43
	15.0	11.8	27.2	1460	68.3	41.6	0.61	2.98	78.4	22.9	1460	56.2	5.38	38.5	106	3.06
50	7.5	2.8	6.4	1460	64.7	40.3	0.62	3.47	76.4	18.7	1460	59.5	5.48	41.4	108	3.18
	7.5	2.8	6.4	1950	67.3	45.6	0.68	3.61	79.6	18.7	1950	60.9	4.92	44.2	99	3.63
	11.3	5.9	13.7	1460	66.0	40.9	0.62	3.28	77.1	20.1	1460	62.6	5.57	44.1	110	3.29
	11.3	5.9	13.7	1950	68.7	46.3	0.67	3.41	80.3	20.1	1950	64.1	5.01	47.1	100	3.75
	15.0	11.1	25.7	1460	66.7	41.2	0.62	3.19	77.5	20.9	1460	64.3	5.63	45.6	111	3.35
	15.0	11.1	25.7	1950	69.4	46.6	0.67	3.32	80.7	20.9	1950	65.9	5.05	48.7	101	3.82
60	7.5	2.6	6.0	1460	62.4	39.3	0.63	3.78	75.3	16.5	1460	66.9	5.70	47.8	112	3.44
	7.5	2.6	6.0	1950	65.0	44.5	0.69	3.93	78.4	16.5	1950	68.5	5.12	51.0	103	3.92
	11.3	5.6	13.0	1460	63.7	39.9	0.63	3.56	75.8	17.9	1460	70.4	5.82	50.9	115	3.55
	11.3	5.6	13.0	1950	66.3	45.1	0.68	3.70	78.9	17.9	1950	72.1	5.22	54.4	104	4.05
	15.0	10.7	24.6	1460	64.2	40.0	0.62	3.45	75.9	18.6	1460	72.4	5.88	52.6	116	3.61
70	7.5	2.4	5.6	1460	59.6	38.0	0.64	4.15	73.7	14.3	1460	74.2	5.93	54.1	117	3.66
	7.5	2.4	5.6	1950	62.0	43.0	0.69	4.32	76.7	14.3	1950	75.9	5.33	57.8	106	4.18
	11.3	5.4	12.5	1460	61.1	38.6	0.63	3.89	74.3	15.7	1460	78.0	6.05	57.5	119	3.78
	11.3	5.4	12.5	1950	63.6	43.7	0.69	4.05	77.4	15.7	1950	79.9	5.44	61.4	108	4.31
	15.0	10.3	23.7	1460	61.6	38.8	0.63	3.77	74.4	16.3	1460	80.1	6.12	59.2	121	3.84
	15.0	10.3	23.7	1950	64.2	43.9	0.68	3.92	77.5	16.3	1950	82.0	5.50	63.2	109	4.37
80	7.5	2.3	5.4	1460	56.4	36.7	0.65	4.59	72.1	12.3	1460	81.1	6.15	60.1	121	3.86
	7.5	2.3	5.4	1950	58.8	41.5	0.71	4.78	75.1	12.3	1950	83.0	5.52	64.2	109	4.41
	11.3	5.2	12.0	1460	58.1	37.3	0.64	4.29	72.7	13.5	1460	84.9	6.27	63.4	124	3.97
	11.3	5.2	12.0	1950	60.4	42.2	0.70	4.47	75.7	13.5	1950	87.0	5.63	67.7	111	4.52
	15.0	9.9	22.9	1460	58.7	37.5	0.64	4.15	72.8	14.1	1460	86.9	6.33	65.1	125	4.02
85	7.5	2.3	5.2	1460	54.8	36.1	0.66	4.84	71.3	11.4	1460	84.1	6.25	62.8	123	3.95
	7.5	2.3	5.2	1950	57.0	40.8	0.72	5.04	74.2	11.4	1950	86.2	5.60	67.0	111	4.50
	11.3	5.1	11.8	1460	56.4	36.6	0.65	4.52	71.9	12.5	1460	87.8	6.40	65.9	126	4.04
	11.3	5.1	11.8	1950	58.7	41.4	0.70	4.71	74.8	12.5	1950	89.9	5.70	70.4	113	4.61
	15.0	9.8	22.6	1460	57.1	36.8	0.64	4.37	72.0	13.1	1460	89.6	6.40	67.5	127	4.09
	15.0	9.8	22.6	1950	59.5	41.6	0.70	4.55	75.0	13.1	1950	91.8	5.80	72.0	114	4.66
90	7.5	2.2	5.1	1460	53.1	35.4	0.67	5.09	70.5	10.4	1460	87.2	6.35	65.4	125	4.03
	7.5	2.2	5.1	1950	55.3	40.1	0.73	5.30	73.4	10.4	1950	89.3	5.70	69.9	112	4.59
	11.3	5.0	11.6	1460	54.8	35.9	0.66	4.76	71.0	11.5	1460	90.7	6.45	68.4	128	4.12
	11.3	5.0	11.6	1950	57.1	40.7	0.71	4.95	74.0	11.5	1950	92.9	5.80	73.1	114	4.70
	15.0	9.6	22.2	1460	55.5	36.1	0.65	4.60	71.2	12.1	1460	92.3	6.50	69.8	129	4.16
100	7.5	2.1	4.9	1460	51.7	34.3	0.69	5.67	69.0	8.8	1950	94.5	5.84	74.5	115	4.74
	7.5	2.1	4.9	1950	51.7	38.9	0.75	5.90	71.9	8.8	1950	94.5	5.84	74.5	115	4.74
	11.3	4.9	11.3	1460	51.4	34.7	0.68	5.29	69.5	9.7	1950	94.5	5.84	74.5	115	4.74
	11.3	4.9	11.3	1950	53.5	39.3	0.73	5.51	72.3	9.7	1950	94.5	5.84	74.5	115	4.74
	15.0	9.4	21.7	1460	52.1	34.8	0.67	5.11	69.6	10.2	1950	94.5	5.84	74.5	115	4.74
	15.0	9.4	21.7	1950	54.2	39.4	0.73	5.32	72.4	10.2	1950	94.5	5.84	74.5	115	4.74
110	7.5	2.0	4.7	1460	46.6	33.8	0.73	6.33	68.2	7.4	1950	94.5	5.84	74.5	115	4.74
	7.5	2.0	4.7	1950	48.5	38.2	0.79	6.59	71.0	7.4	1950	94.5	5.84	74.5	115	4.74
	11.3	4.8	11.0	1460	47.8	33.6	0.70	5.91	68.0	8.1	1950	94.5	5.84	74.5	115	4.74
	11.3	4.8	11.0	1950	49.8	38.1	0.76	6.15	70.8	8.1	1950	94.5	5.84	74.5	115	4.74
	15.0	9.2	21.2	1460	48.6	33.7	0.69	5.71	68.2	8.5	1950	94.5	5.84	74.5	115	4.74
120	7.5	2.0	4.6	1460	43.0	33.1	0.77	7.07	67.2	6.1	1950	94.5	5.84	74.5	115	4.74
	7.5	2.0	4.6	1950	44.7	37.5	0.84	7.36	70.0	6.1	1950	94.5	5.84	74.5	115	4.74
	11.3	4.7	10.7	1460	44.2	32.8	0.74	6.61	66.8	6.7	1950	94.5	5.84	74.5	115	4.74
	11.3	4.7	10.7	1950	46.0	37.1	0.81	6.88	69.6	6.7	1950	94.5	5.84	74.5	115	4.74
	15.0	9.0	20.7	1460	44.9	32.7	0.73	6.38	66.8	7.0	1950	94.5	5.84	74.5	115	4.74
	15.0	9.0	20.7	1950	46.8	37.0	0.79	6.64	69.5	7.0	1950	94.5	5.84	74.5	115	4.74

NOTE: See Legend and Notes on page 25.





**LEGEND AND NOTES FOR PAGES 14-24**

**LEGEND**

- AHRI** — Air-Conditioning, Heating, and Refrigeration Institute
- db** — Dry Bulb
- COP** — Coefficient of Performance
- EAT** — Entering Air Temperature (F)
- EER** — Energy Efficiency Ratio
- EWT** — Entering Water Temperature (F)
- GPM** — Gallons per Minute
- HC** — Heating Capacity (MBtuh)
- HE** — Heat of Extraction (MBtuh)
- HR** — Heat of Rejection (MBtuh)
- ISO** — International Organization for Standardization
- LAT** — Latent Heat (MBtuh)
- LWT** — Leaving Water Temperature
- MBtuh** — Btuh in Thousands
- SC** — Sensible Capacity (MBtuh)
- TC** — Total Capacity (MBtuh)
- wb** — Wet Bulb
- WPD** — Water Pressure Differential

**NOTES:**

1. Interpolation is permissible; extrapolation is not.
2. All entering air conditions are 80 F db and 67 F wb in cooling and 70 F db in heating.
3. AHRI/ISO certified conditions are 80.6 F db and 66.2 F wb in cooling and 68 F db in heating.
4. Table does not reflect fan or pump power corrections for AHRI/ISO conditions.
5. All performance is based upon the lower voltage of dual voltage rated units.
6. Operation below 40 F EWT is based upon a 15% antifreeze solution.
7. Operation below 60 F EWT requires optional insulated water/refrigerant circuit.
8. See performance correction tables for operating conditions other than those listed above.
9. For operation in the shaded area when water is used instead of an anti-freeze solution, the LWT must be calculated. Flow must be maintained to a level so that the LWT is maintained above 40 F when the JW3 jumper is not clipped. Because the refrigerant temperature can potentially reach as low as 32 F with 40 F LWT, a nuisance cutout could occur due to the activation of the low temperature protection. JW3 should never be clipped for standard range equipment or systems without antifreeze.

**AIRFLOW CORRECTION TABLE**

AIRFLOW % of Nominal	COOLING					HEATING		
	Total Capacity	Sensible Capacity	Sensible/Total Ratio	kW	THR	Heating Capacity	Power	Heat of Extraction
75	0.976	1.113	0.937	0.961	0.884	0.920	0.961	0.961
81.25	0.983	1.079	0.955	0.973	0.913	0.938	0.969	0.972
87.5	0.989	1.048	0.972	0.984	0.939	0.955	0.978	0.983
93.75	0.995	1.022	0.987	0.993	0.967	0.974	0.989	0.992
100	1.000	1.000	1.000	1.000	1.000	1.000	1.000	1.000
106.25	1.005	0.982	1.012	1.006	1.043	1.038	1.012	1.007
112.5	1.010	0.968	1.022	1.009	1.102	1.092	1.025	1.013
118.75	1.014	0.958	1.030	1.011	1.179	1.166	1.039	1.017
125	1.018	0.953	1.037	1.012	1.280	1.265	1.054	1.020

**LEGEND**

- THR** — Total Heat of Rejection (MBtuh)

**ENTERING AIR CORRECTION TABLE — HEATING**

HEATING CORRECTIONS			
Ent Air DB (F)	Heating Capacity	kW	Heat of Extraction
45	1.051	0.780	1.131
50	1.033	0.823	1.095
55	1.020	0.868	1.065
60	1.010	0.917	1.038
65	1.003	0.968	1.014
68	1.000	1.000	1.000
70	0.998	1.022	0.991
75	0.993	1.078	0.967
80	0.987	1.137	0.942

**LEGEND**

- DB** — Dry Bulb

# Performance data (cont)



## ENTERING AIR CORRECTION TABLE — COOLING

COOLING CORRECTIONS												
Ent Air WB (F)	Total Cooling Capacity	Sensible Cooling Capacity Multiplier - Entering DB (F)								kW	THR	
		65	70	75	80	80.6	85	90	95			
50	0.780	0.978	*	*	*	*	*	*	*	*	0.997	0.824
55	0.833	0.897	1.056	*	*	*	*	*	*	*	0.998	0.867
60	0.895	0.751	0.918	1.106	*	*	*	*	*	*	0.999	0.917
65	0.968	—	0.678	0.899	1.121	1.148	1.344	*	*	*	1.000	0.975
66.2	0.987	—	0.610	0.842	1.070	1.067	1.294	*	*	*	1.000	0.990
67	1.000	—	0.551	0.778	1.000	1.026	1.216	1.427	*	*	1.000	1.000
70	1.051	—	—	0.641	0.886	0.914	1.108	1.309	1.487	*	1.001	1.040
75	1.144	—	—	—	0.609	0.640	0.857	1.066	1.238	*	1.001	1.114

LEGEND

DB — Dry Bulb  
 THR — Total Heat of Rejection  
 WB — Wet Bulb

\*Sensible capacity equals total capacity.

NOTE: AHRI/ISO/ASHRAE 13256-1 uses entering air conditions of Cooling — 80.6 F db/66.2 F wb and Heating — 68 F db/59 F wb.

## ANTIFREEZE CORRECTION TABLE

ANTIFREEZE TYPE	ANTIFREEZE %	COOLING			HEATING		WPD CORRECTION FACTOR
		EWT 90 F			EWT 30 F		
		Total Capacity	Sensible Capacity	kW	Heating Capacity	kW	
Water	0	1.000	1.000	1.000	1.000	1.000	1.000
Propylene Glycol	5	0.995	0.995	1.003	0.989	0.997	1.070
	15	0.986	0.986	1.009	0.968	0.990	1.210
	25	0.978	0.978	1.014	0.947	0.983	1.360
Methanol	5	0.997	0.997	1.002	0.989	0.997	1.070
	15	0.990	0.990	1.007	0.968	0.990	1.160
	25	0.982	0.982	1.012	0.949	0.984	1.220
Ethanol	5	0.998	0.998	1.002	0.981	0.994	1.140
	15	0.994	0.994	1.005	0.944	0.983	1.300
	25	0.986	0.986	1.009	0.917	0.974	1.360
Ethylene Glycol	5	0.998	0.998	1.002	0.993	0.998	1.040
	15	0.994	0.994	1.004	0.980	0.994	1.120
	25	0.988	0.988	1.008	0.966	0.990	1.200

LEGEND

EWT — Entering Wet Bulb  
 WPD — Water Pressure Differential



### 50PCH,PCV BLOWER PERFORMANCE — STANDARD UNIT

50PCH, PCV	FAN SPEED	RATED AIRFLOW	MIN CFM	AIRFLOW (cfm) AT EXTERNAL STATIC PRESSURE (in. wg)															
				0.00	0.05	0.10	0.15	0.20	0.25	0.30	0.35	0.40	0.45	0.50	0.60	0.70	0.80	0.90	1.00
006	Hi	220	150			310	300	290	280	270	250	230	210	180					
	Med			260	250	240	230	210	200	190	180								
009	Hi	325	225			410	400	380	360	350	330	320	300	280					
	Med			390	370	360	340	320	310	290	280	260							
012	Hi	400	300			470	460	450	440	430	420	400	390	380	320				
	Med			420	410	400	390	380	370	360	350	340							
015	Hi	525	375			745	725	706	696	686	666	637	588	539	451				
	Med			686	676	666	657	647	637	617	608	588	549	510	451				
018	Hi	600	450			745	725	706	696	686	666	637	588	539	451				
	Med			686	676	666	657	647	637	617	608	588	549	510	451				
024	Hi	800	600			941	931	912	893	874	855	836	817	789	732	656			
	Med			960	950	941	931	912	893	874	855	836	817	789	732	656			
030	Hi	1000	750			1140	1121	1093	1064	1102	1074	1045	1017	979	903	798			
	Med			1188	1169	1140	1121	1093	1064	1102	1074	1045	1017	979	903	798			
036	Hi	1200	900			1436	1416	1387	1358	1329	1310	1280	1232	1174	1077	931			
	Med			1474	1455	1436	1416	1387	1358	1329	1310	1280	1232	1174	1077	931			
042	Hi	1350	1050			1501	1473	1444	1416	1378	1340	1302	1264	1226	1131				
	Med			1558	1530	1501	1473	1444	1416	1378	1340	1302	1264	1226	1131	1064			
048	Hi	1600	1200			1805	1786	1881	1853	1815	1767	1710	1653	1596	1416	1216	1216		
	Med			1843	1824	1805	1786	1881	1853	1815	1767	1710	1653	1596	1416	1216	1216		
060	Hi	2000	1500			2176	2156	2117	2078	2048	2019	1999	1970	1921	1842	1754	1627		
	Med			2195	2195	2185	2176	2156	2117	2078	2048	2019	1999	1970	1921	1842	1754	1627	

NOTES:

1. Shaded areas denote ESP (external static pressure) where operation is not recommended.
2. Units factory shipped on medium speed. Other speeds require field selection.
3. All airflow is rated and shown above at lowest voltage if unit is dual voltage rated, i.e., 208-v for 208/230-v units.
4. Only two-speed fan (Hi and Med) available on 575-v units.
5. Performance stated is at the rated power supply. Performance may vary as the power supply varies from the rated.

### 50PCH,PCV BLOWER PERFORMANCE — HIGH-STATIC UNIT

50PCH, PCV	FAN SPEED	RATED AIRFLOW	MIN CFM	AIRFLOW (cfm) AT EXTERNAL STATIC PRESSURE (in. wg)															
				0.00	0.05	0.10	0.15	0.20	0.25	0.30	0.35	0.40	0.45	0.50	0.60	0.70	0.80	0.90	1.00
015	Hi	525	375			774	764	755	745	735	715	696	676	637	519				
	Med			735	725	706	696	686	676	657	647	637	617	588	480				
018	Hi	600	450			774	764	755	745	735	715	696	676	637	519				
	Med			735	725	706	696	686	676	657	647	637	617	588	480				
024	Hi	800	600									988	960	979	903	789	665		
	Med							979	960	931	912	884	855	827	751	675	675		
030	Hi	1000	750									1074	1026	1102	988	874	760		
	Med			998	988	979	960	941	931	912	893	865	836	798	884	779	884	779	
036	Hi	1200	900									1484	1455	1426	1358	1251	1135	931	
	Med			1319	1310	1300	1290	1280	1271	1261	1242	1222	1213	1193	1116	1038			
042	Hi	1350	1050									1397	1387	1378	1311	1178			
	Med			1321	1311	1302	1292	1473	1463	1444	1425	1425	1235	1216	1188	1121			
048	Hi	1600	1200									1957	1938	1910	1862	1786	1701	1577	1435
	Med			1948	1948	1938	1919	1891	1872	1843	1824	1796	1767	1739	1691	1625	1539	1416	1254
060	Hi	2000	1500									2254	225	2195	2156	2087	2019	1940	1852
	Med			2352	2352	2342	2332	2323	2313	2293	2274	2254	225	2195	2156	2087	2019	1940	1852

NOTES:

1. Shaded areas denote ESP (external static pressure) where operation is not recommended.
2. Units factory shipped on medium speed. Other speeds require field selection.
3. All airflow is rated and shown above at lowest voltage if unit is dual voltage rated, i.e., 208-v for 208/230-v units.
4. Only two-speed fan (Hi and Med) available on 575-v units.
5. Performance stated is at the rated power supply. Performance may vary as the power supply varies from the rated.
6. High-static blower not available on unit sizes 006-012.

# Electrical data



## 50PCH,PCV UNIT ELECTRICAL DATA

50PCH,PCV UNIT	VOLTAGE CODE	RATED VOLTAGE V-Ph-Hz*	VOLTAGE MIN/MAX	COMPRESSOR			STANDARD UNITS				UNITS WITH HIGH-STATIC BLOWER			
				QTY	RLA	LRA	Fan Motor FLA	Total Unit FLA	Min Circuit AMP	Max Fuse/HACR	Fan Motor FLA	Total Unit FLA	Min Circuit AMP	Max Fuse/HACR
006	3	208/230-1-60	197/254	1	3.3	17.7	0.40	3.7	4.5	15	—	—	—	—
	4	265-1-60	239/292	1	2.9	13.5	0.40	3.3	4.0	15	—	—	—	—
009	3	208/230-1-60	197/254	1	5.6	22.2	0.80	6.4	7.8	15	—	—	—	—
	4	265-1-60	239/292	1	3.8	18.8	0.70	4.5	5.5	15	—	—	—	—
012	3	208/230-1-60	197/254	1	5.1	32.5	0.80	5.9	7.2	15	—	—	—	—
	4	265-1-60	239/292	1	4.0	31.5	0.70	4.7	5.7	15	—	—	—	—
015	3	208/230-1-60	197/254	1	6.0	29.0	1.00	7.0	8.5	15	1.00	7.0	8.5	15
	4	265-1-60	239/292	1	5.4	28.0	0.86	6.3	7.6	15	0.86	6.3	7.6	15
018	3	208/230-1-60	197/254	1	7.2	33.0	1.00	8.2	10.0	15	1.50	8.7	10.5	15
	4	265-1-60	239/292	1	5.9	28.0	0.86	6.8	8.2	15	1.30	7.2	8.7	15
024	3	208/230-1-60	197/254	1	12.8	58.3	1.50	14.3	17.5	30	3.00	15.8	19.0	30
	4	265-1-60	239/292	1	9.6	54.0	1.30	10.9	13.3	20	2.70	12.3	14.7	20
030	3	208/230-1-60	197/254	1	14.1	73.0	3.00	17.1	20.6	30	3.00	17.1	20.6	30
	4	265-1-60	239/292	1	11.2	60.0	2.70	13.9	16.7	25	2.70	13.9	16.7	25
	5	208/230-3-60	197/254	1	8.9	58.0	3.00	11.9	14.1	20	3.00	11.9	14.1	20
	6	460-3-60	414/506	1	4.2	28.0	1.70	5.9	7.0	15	1.70	5.9	7.0	15
036	3	208/230-1-60	197/254	1	16.7	79.0	1.80	18.5	22.7	35	3.00	19.7	23.9	40
	4	265-1-60	239/292	1	13.5	72.0	2.00	15.5	18.9	30	2.70	16.2	19.6	30
	5	208/230-3-60	197/254	1	10.4	73.0	1.80	12.2	14.8	25	3.00	13.4	16.0	25
	6	460-3-60	414/506	1	5.8	38.0	1.24	7.0	8.5	15	1.70	7.5	9.0	15
042	3	208/230-1-60	197/254	1	17.9	112.0	3.00	20.9	25.4	40	3.00	20.9	25.4	40
	5	208/230-3-60	197/254	1	13.5	88.0	3.00	16.5	19.9	30	3.00	16.5	19.9	30
	6	460-3-60	414/506	1	6.0	44.0	1.70	7.7	9.2	15	1.70	7.7	9.2	15
	1	575-3-60	518/633	1	4.9	34.0	1.40	6.3	7.5	15	1.40	6.3	7.5	15
048	3	208/230-1-60	197/254	1	21.8	117.0	3.40	25.2	30.7	50	4.90	26.7	32.2	50
	5	208/230-3-60	197/254	1	13.7	83.1	3.40	17.1	20.5	30	4.90	18.6	22.0	35
	6	460-3-60	414/506	1	6.2	41.0	1.80	8.0	9.6	15	2.50	8.7	10.3	15
1	575-3-60	518/633	1	4.8	33.0	1.40	6.2	7.4	15	1.90	6.7	7.9	15	
060	3	208/230-1-60	197/254	1	26.3	134.0	4.90	31.2	37.8	60	5.80	32.1	38.7	60
	5	208/230-3-60	197/254	1	15.6	110.0	4.90	20.5	24.4	40	5.80	21.4	25.3	40
	6	460-3-60	414/506	1	7.8	52.0	2.50	10.3	12.3	20	2.60	10.4	12.4	20
	1	575-3-60	518/633	1	5.8	38.9	1.90	7.7	9.2	15	2.30	8.1	9.6	15

LEGEND

- FLA — Full Load Amps
- HACR — Heating, Air Conditioning and Refrigeration
- LRA — Locked Rotor Amps
- RLA — Rated Load Amps

\*The 460-v units using an internal secondary pump will require a neutral wire from the supply side in order to feed the accessory with 265-v.

NOTES:

1. HACR circuit breaker in U.S.A. only.
2. All fuses Class RK-5.
3. High-static blower not available on unit sizes 006-012.

# Typical piping and wiring



## TYPICAL HORIZONTAL INSTALLATION — 50PCH UNITS

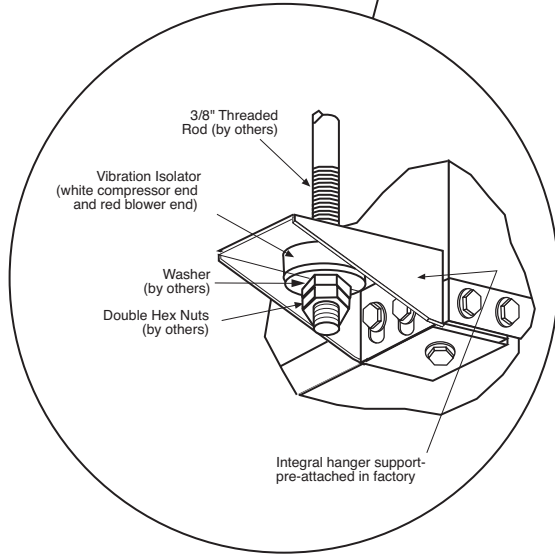
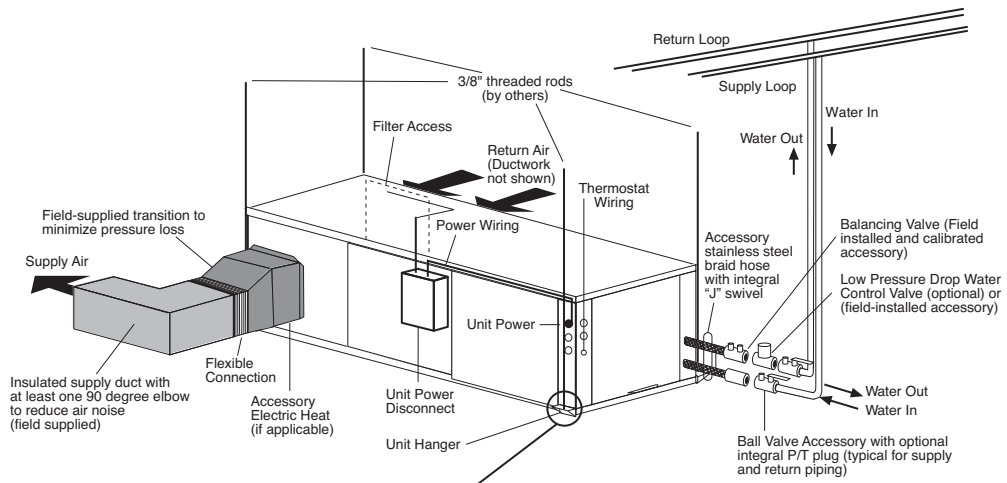

## TYPICAL VERTICAL INSTALLATION — 50PCV UNITS

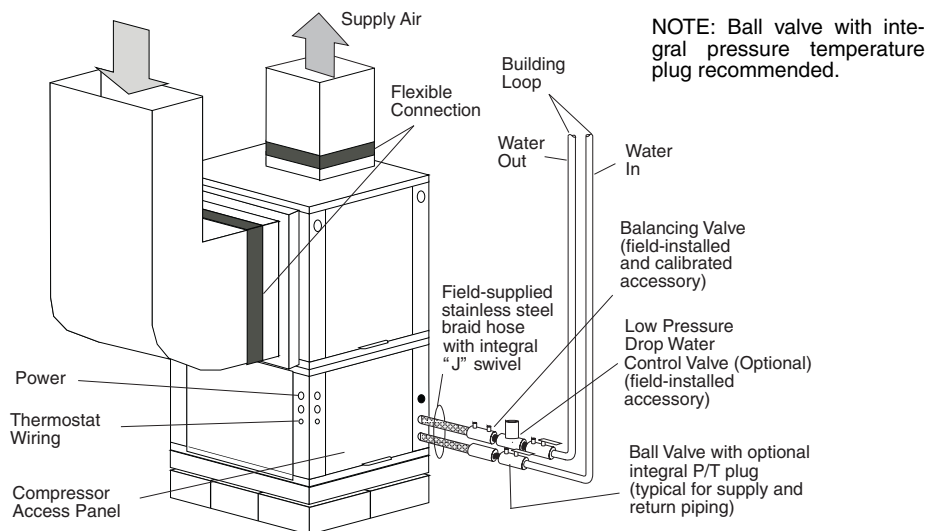

# Typical control wiring schematics



## 50PCH,PCV UNITS WITH COMPLETE C CONTROLLER, SINGLE-PHASE

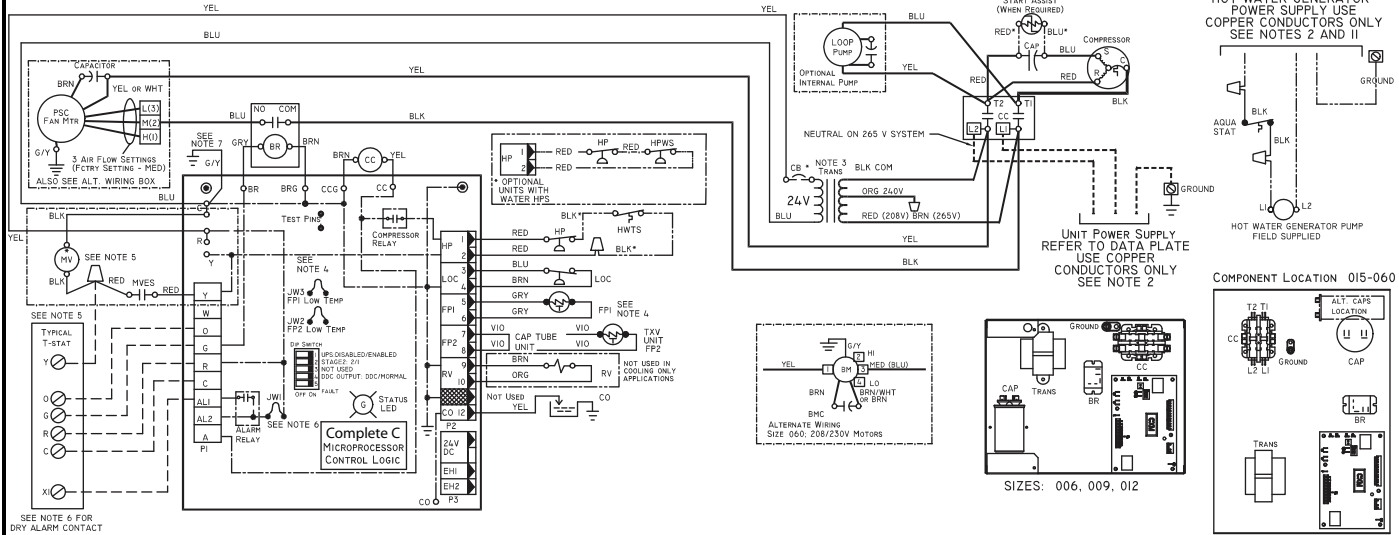

### LEGEND

- AL** — Alarm Relay Contacts
- BM** — Blower Motor
- BMC** — Blower Motor Capacitor
- BR** — Blower Relay
- CAP** — Compressor Capacitor
- CB** — Circuit Breaker
- CC** — Compressor Contactor
- CO** — Sensor, Condensate Overflow
- FP1** — Sensor, Low Temperature Protection Water Coil
- FP2** — Sensor, Low Temperature Protection Air Coil
- HP** — High-Pressure Switch
- HPWS** — High-Pressure Water Switch
- HWTS** — High Leaving Water Temperature Switch
- JW1** — Jumper, Alarm

- LOC** — Loss of Charge Pressure Switch
- MV** — Motorized Valve
- MVES** — Motorized Valve End Switch
- NEC** — National Electrical Code
- P1** — Field Wiring Terminal Block
- PSC** — Permanent Split Capacitor
- RV** — Reversing Valve Coil
- TRANS** — Transformer
- TXV** — Thermostatic Expansion Valve
- Field Line Voltage Wiring
- - - Field Low Voltage Wiring
- . - Printed Circuit Trace
- . . Optional Wiring

- Relay/Contactor Coil
- Condensate Pan
- Solenoid Coil
- Temperature Switch
- Thermistor
- Ground
- Wire Nut

\*Optional.

### NOTES:

1. Compressor and blower motor thermally protected internally.
2. All wiring to the unit must comply with NEC and local codes.
3. Transformer for 208/230 v will be connected for 208 v operation. For 230 v operation, switch RED wire to ORG wire. Insulate open end of RED lead. Transformer is energy limiting or may have circuit breaker.
4. FP1 thermistor provides freeze protection for water. When using antifreeze solutions, cut JW3 jumper.
5. Typical heat pump thermostat wiring shown. Refer to thermostat installation instructions for wiring to the unit. Wire "Y" from thermostat to "Y" Complete C when a motorized valve is not used. "O" terminal is not used in cooling only applications. Thermostat wiring must be Class 1 and voltage rating equal to or greater than unit supply voltage.

6. 24-v alarm signal shown. For dry alarm contact, cut JW1 jumper and for anti-freeze solutions, cut JW3 jumper.
7. Transformer secondary ground via green wire with yellow stripe from "C" terminal to control box.
8. Hot water generator pump only in models with hot water generation and internal pump option.
9. For auxiliary staging options, consult electric heat installation manual.
10. Fan motors factory wired for medium speed. For high or low speed, remove BLU wire from fan motor speed trap "M" and connect to "H" for high speed or "L" for low speed.
11. Aquastat is with unit and must be wired in series with the hot leg to the pump. Aquastat is rated for voltage up to 277 v.

## 50PCH,PCV UNITS WITH DELUXE D CONTROLLER, THREE-PHASE (208/230 V)

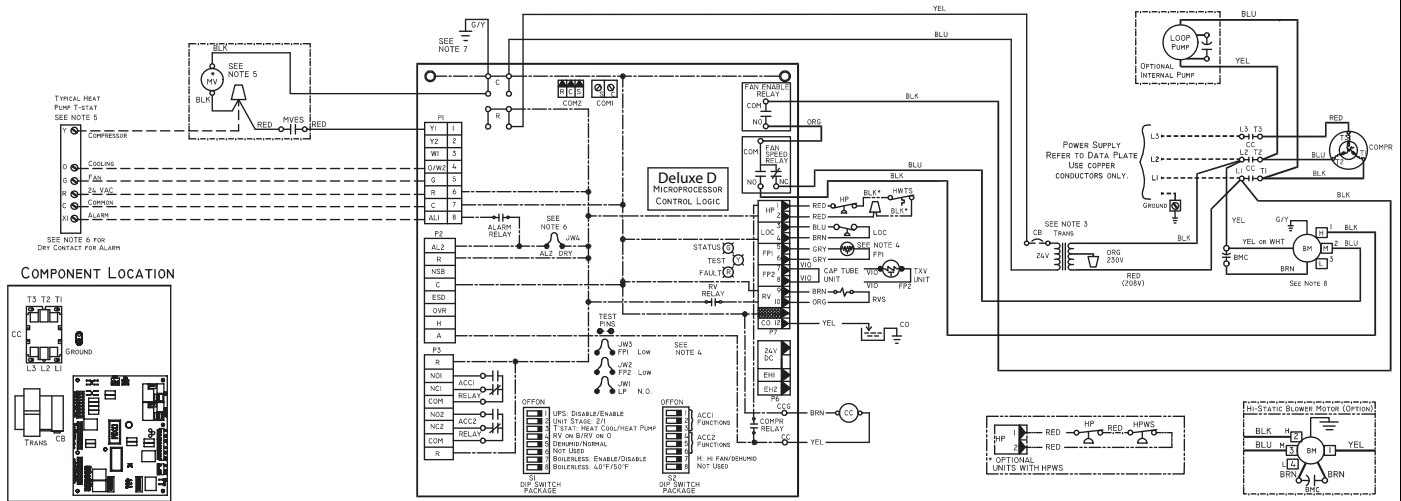

- AL** — Alarm Relay Contacts
- BM** — Blower Motor
- BMC** — Blower Motor Capacitor
- BR** — Blower Relay
- CAP** — Compressor Capacitor
- CB** — Circuit Breaker
- CC** — Compressor Contactor
- CO** — Sensor, Condensate Overflow
- FP1** — Sensor, Low Temperature Protection Water Coil
- FP2** — Sensor, Low Temperature Protection Air Coil
- HP** — High-Pressure Switch
- HPWS** — High-Pressure Water Switch
- HWTS** — High Leaving Water Temperature Switch
- JW1** — Jumper, Alarm

### LEGEND

- |  |   |
|--|---|
| <ul style="list-style-type: none"> <li><b>LOC</b> — Loss of Charge Pressure Switch</li> <li><b>MV</b> — Motorized Valve</li> <li><b>MVES</b> — Motorized Valve End Switch</li> <li><b>NEC</b> — National Electrical Code</li> <li><b>P1</b> — Field Wiring Terminal Block</li> <li><b>RVS</b> — Reversing Valve Solenoid</li> <li><b>TRANS</b> — Transformer</li> <li><b>TXV</b> — Thermostatic Expansion Valve</li> </ul> | <ul style="list-style-type: none"> <li> Relay/Contactor Coil</li> <li> Condensate Pan</li> <li> Solenoid Coil</li> <li> Thermistor</li> <li> Ground</li> <li> Wire Nut</li> </ul> |
|--|---|
- - - - - Field Line Voltage Wiring  
 - - - - - Field Low Voltage Wiring  
 - · - · - Printed Circuit Trace  
 - · · - Optional Wiring

\*Optional.

#### NOTES:

1. Compressor thermally protected internally.
2. All wiring to the unit must comply with NEC and local codes.
3. Transformer is wired to 208-v RED lead for 208-3-60 units. For 230-3-60, switch RED and ORG leads at L1 and insulate RED lead. Transformer is energy limiting or may have circuit breaker.
4. FP1 thermistor provides freeze protection for water. When using antifreeze solutions, cut JW3 jumper.
5. Refer to microprocessor control, LON, or thermostat installation instructions for wiring to the unit. Wire "Y" from thermostat to "Y1" Deluxe D when motorized valve is not used. Thermostat wiring must be Class 1 and voltage rating equal to or greater than unit supply voltage. Heat/cool thermostats not compatible with motorized water valve.
6. 24-v alarm signal shown. For dry alarm contact, cut JW4 jumper and dry contact will be available between AL1 and AL2.
7. Transformer secondary ground via green wire with yellow stripe from "C" terminal to control box.
8. Blower motor is factory wired for medium and high speeds. For any other combination of speeds, attach black wire to the higher of the two desired speed taps and the blue wire to the lower of the two desired speed taps.

# Typical control wiring schematics (cont)



## 50PCH,PCV UNITS WITH DELUXE D CONTROLLER, THREE-PHASE (460 V)

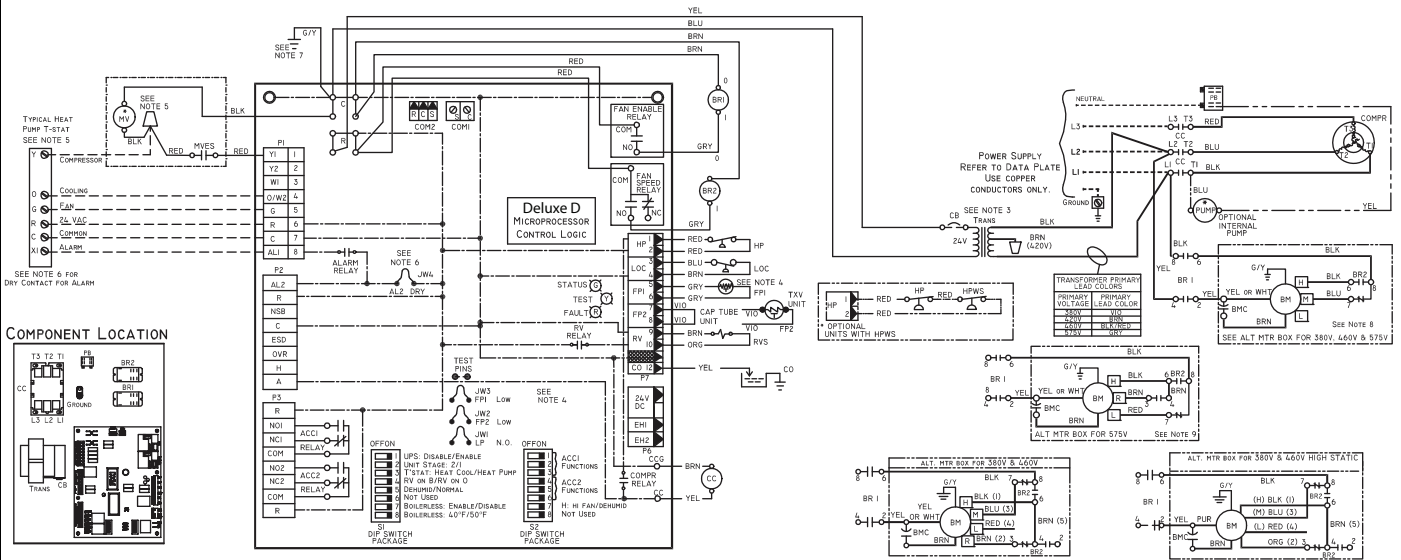

### LEGEND

- |  |   |                      |
|--|---|----------------------|
| <b>AL</b> — Alarm Relay Contacts                           | <b>LOC</b> — Loss of Charge Pressure Switch | Relay/Contactor Coil |
| <b>BM</b> — Blower Motor                                   | <b>MV</b> — Motorized Valve                 | Condensate Pan       |
| <b>BMC</b> — Blower Motor Capacitor                        | <b>MVES</b> — Motorized Valve End Switch    | Solenoid Coil        |
| <b>BR</b> — Blower Relay                                   | <b>NEC</b> — National Electrical Code       | Thermistor           |
| <b>CAP</b> — Compressor Capacitor                          | <b>P1</b> — Field Wiring Terminal Block     | Ground               |
| <b>CB</b> — Circuit Breaker                                | <b>PB</b> — Power Block                     | Wire Nut             |
| <b>CC</b> — Compressor Contactor                           | <b>RVS</b> — Reversing Valve Solenoid       |                      |
| <b>CCH</b> — Crankcase Heater                              | <b>TRANS</b> — Transformer                  |                      |
| <b>CO</b> — Sensor, Condensate Overflow                    | <b>TXV</b> — Thermostatic Expansion Valve   |                      |
| <b>FP1</b> — Sensor, Low Temperature Protection Water Coil | Field Line Voltage Wiring                   |                      |
| <b>FP2</b> — Sensor, Low Temperature Protection Air Coil   | Field Low Voltage Wiring                    |                      |
| <b>HP</b> — High-Pressure Switch                           | Printed Circuit Trace                       |                      |
| <b>HPWS</b> — High-Pressure Water Switch                   | Optional Wiring                             |                      |
| <b>JW1</b> — Clippable Field Selection Jumper              |   |                      |

\*Optional.

### NOTES:

- Compressor thermally protected internally.
- All wiring to the unit must comply with NEC and local codes.
- Transformer is wired to 460-v BLK/RED lead for 460-3-60 units or 575-v GRY lead for 575-3-60 units. Transformer is energy limiting or may have circuit breaker.
- FP1 thermistor provides low temperature protection for water. When using antifreeze solutions, cut JW3 jumper.
- Refer to microprocessor control, LON, or thermostat installation instructions for wiring to the unit. Wire "Y" from thermostat to "Y1" Deluxe D when motorized valve is not used. Thermostat wiring must be Class 1 and voltage rating equal to or greater than unit supply voltage. Heat/cool thermostats not compatible with motorized water valve.
- 24-v alarm signal shown. For dry alarm contact, cut JW4 jumper and dry contact will be available between AL1 and AL2.
- Transformer secondary ground via green wire with yellow stripe from "C" terminal to control box.
- Blower motor is factory wired for medium and high speeds. For any other combination of speeds, attach black wire to the higher of the two desired speed taps at the motor. Attach the blue wire to the lower of the two desired speed taps.
- Blower motor is factory wired for high and low speeds. No other combination of speeds is available.
- The 460-v units using an internal secondary pump will require a neutral wire from the supply side in order to feed the accessory with 265-v.



## 50PCH,PCV UNITS WITH COMPLETE C AND LON CONTROLLER (460 V)

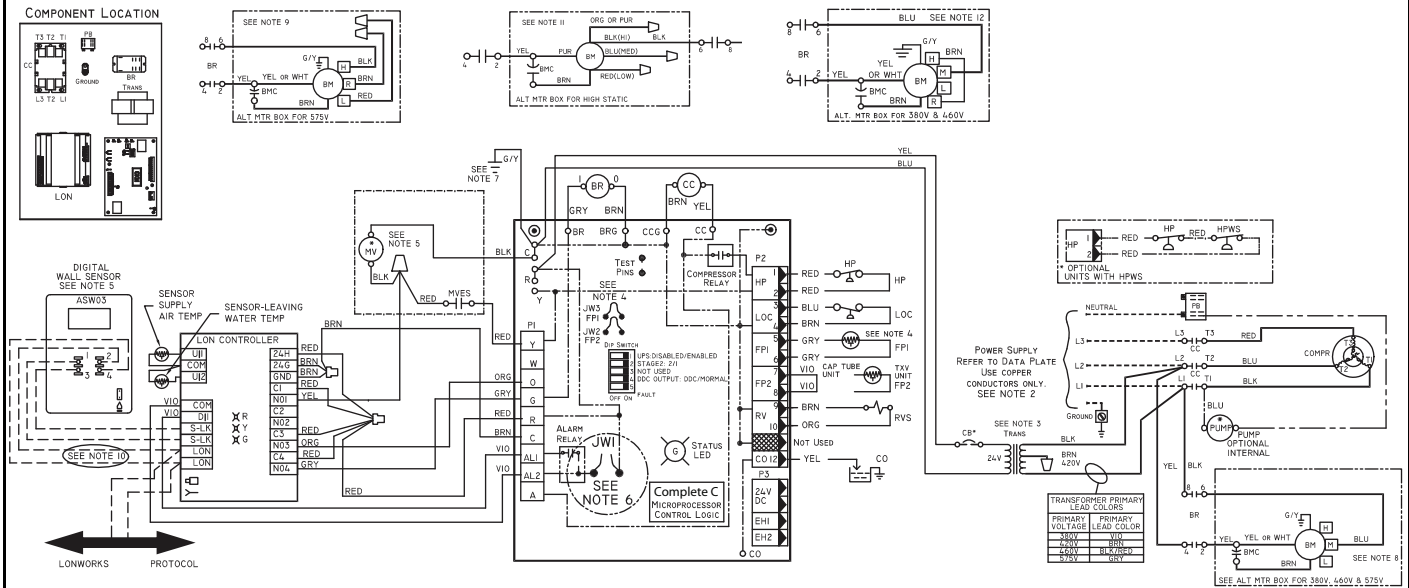

### LEGEND

- |   |   |   |
|---|---|---|
| <p><b>AL</b> — Alarm Relay Contacts</p> <p><b>BM</b> — Blower Motor</p> <p><b>BMC</b> — Blower Motor Capacitor</p> <p><b>BR</b> — Blower Relay</p> <p><b>CAP</b> — Compressor Capacitor</p> <p><b>CB</b> — Circuit Breaker</p> <p><b>CC</b> — Compressor Contactor</p> <p><b>CO</b> — Sensor, Condensate Overflow</p> <p><b>FP1</b> — Sensor, Low Temperature Protection, Water Coil</p> <p><b>FP2</b> — Sensor, Low Temperature Protection, Air Coil</p> <p><b>HP</b> — High-Pressure Switch</p> <p><b>HPWS</b> — High-Pressure Water Switch</p> <p><b>JW1</b> — Clippable Field Selection Jumper</p> <p><b>LOC</b> — Loss of Charge Pressure Switch</p> <p><b>LON</b> — Local Operating Network</p> <p><b>MV</b> — Motorized Valve</p> <p><b>MVES</b> — Motorized Valve End Switch</p> <p>*Optional Wiring.</p> | <p><b>NEC</b> — National Electrical Code</p> <p><b>P1</b> — Field Wiring Terminal Block</p> <p><b>RVS</b> — Reversing Valve Solenoid</p> <p><b>TRANS</b> — Transformer</p> <p><b>TXV</b> — Thermostatic Expansion Valve</p> <p>--- Field Line Voltage Wiring</p> <p>--- Field Low Voltage Wiring</p> <p>- - - Printed Circuit Trace</p> <p>... Optional Wiring</p> <p>○ Relay/Contactor Coil</p> <p>□ Condensate Pan</p> <p>⊂ Solenoid Coil</p> <p>⊂ Temperature Switch</p> | <p>⊕ Thermistor</p> <p>⊕ Ground</p> <p>⊕ Wire Nut</p> <p>⊕ Relay Contacts - N.C.</p> <p>⊕ Relay Contacts - N.O.</p> <p>⊕ Low Pressure Switch</p> <p>⊕ High Pressure Switch</p> <p>⊕ Splice Cap</p> <p>⊕ Circuit Breaker</p> |
|---|---|---|

### NOTES:

1. Compressor and blower motor thermally protected internally.
2. All wiring to the unit must comply with NEC and local codes.
3. Transformer is wired to 460 v BLK/RED lead for 460-3-60 units. Transformer is energy limiting or may have circuit breaker.
4. FP1 thermistor provides low temperature protection for water. When using antifreeze solutions, cut JW3 jumper.
5. Refer to microprocessor control, LON, or thermostat installation instructions for wiring to the unit. Wire "N01" from LON to "Y1" Complete C when a motorized valve is not used. Low voltage wiring must be Class 1 and voltage rating equal to or greater than unit supply voltage.
6. Factory cut JW1 jumper. Dry contact will be available between AL1 and AL2.
7. Transformer secondary ground via green wire with yellow strip from "C" terminal to control box.
8. Fan motors are factory wired for medium speed. For high or low speed, remove BLU wire from fan motor speed tap "M" and connect to "H" for high speed or "L" for low speed.
9. For low speed, remove BLK wire from BR "6" and replace with RED. Connect BLK and BRN wires together.
10. Optional LON wires. Only connect if LON connection is desired at the wall sensor.
11. For blower motors with leads. For medium or low speed, disconnect BLK wire from BR "6". Connect BLK and ORG/PUR wire together. Connect RED for low or BLU for medium to BR "6".
12. Blower motor factory wired to medium speed. For low speed remove BLU wire from medium tap and connect to low speed tap. For high speed, remove BLU wire from existing speed tap and remove BRN jumper wire from high speed tap. Connect BLU wire to high speed tap. Tape off unconnected end of BRN jumper.
13. The 460-v units using an internal secondary pump will require a neutral wire from the supply side in order to feed the accessory with 265-v.

# Typical control wiring schematics (cont)



## 50PCH, PCV UNITS WITH DELUXE D AND LON CONTROLLER (460 V)

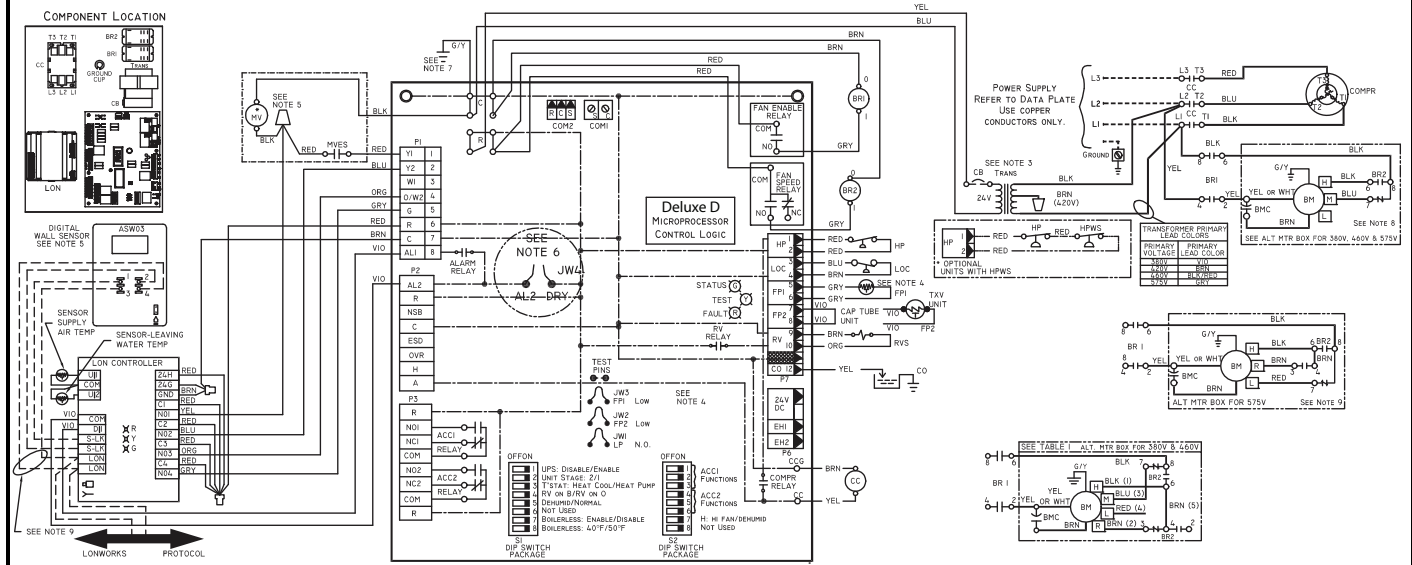

- AL** — Alarm Relay Contacts
  - BM** — Blower Motor
  - BMC** — Blower Motor Capacitor
  - BR** — Blower Relay
  - CAP** — Compressor Capacitor
  - CB** — Circuit Breaker
  - CC** — Compressor Contactor
  - CO** — Sensor, Condensate Overflow
  - FP1** — Sensor, Low Temperature Protection, Water Coil
  - FP2** — Sensor, Low Temperature Protection, Air Coil
  - HP** — High-Pressure Switch
  - HPWS** — High-Pressure Water Switch
  - JW1** — Clippable Field Selection Jumper
  - LOC** — Loss of Charge Pressure Switch
  - LON** — Local Operating Network
  - MV** — Motorized Valve
  - MVES** — Motorized Valve End Switch
- \*Optional Wiring.

- NEC** — National Electrical Code
- P1** — Field Wiring Terminal Block
- RVS** — Reversing Valve Solenoid
- TRANS** — Transformer
- TXV** — Thermostatic Expansion Valve
- --- --- Field Line Voltage Wiring
- - - - - Field Low Voltage Wiring
- . - . - Printed Circuit Trace
- . . . - Optional Wiring
- Relay/Contactor Coil
- Condensate Pan
- ⊞ Solenoid Coil
- ⊞ Temperature Switch

- ⊞ Thermistor
- ⊞ Ground
- ⊞ Wire Nut
- ⊞ Relay Contacts - N.C.
- ⊞ Relay Contacts - N.O.
- ⊞ Low Pressure Switch
- ⊞ High Pressure Switch
- ⊞ Splice Cap
- ⊞ Circuit Breaker

**NOTES:**

1. Compressor and blower motor thermally protected internally.
2. All wiring to the unit must comply with NEC and local codes.
3. Transformer is wired to 460-v BLK/RED lead for 460-3-60 units. Transformer is energy limiting or may have circuit breaker.
4. FP1 thermistor provides low temperature protection for water. When using antifreeze solutions, cut JW3 jumper.
5. Refer to microprocessor control, LON, thermostat installation instructions for wiring to the unit. Wire "N01" from LON to "Y1" Deluxe D when motorized valve is not used. Thermostat wiring must be Class 1 and voltage rating equal to or greater than unit supply voltage.
6. Factory cut JW4 jumper. Dry contact will be available between AL1 and AL2.
7. Transformer secondary ground via green wire with yellow stripe from "C" terminal to control box.
8. Blower motor is factory wired for medium and high speeds. For any other combination of speeds, attach black wire to the higher of the two desired speed taps at the motor, and attach the blue wire to the lower of the two desired speed taps.
9. Blower motor is factory wired for high and low speeds. No other combination is available.
10. Optional LON wires. Only connect if LON connection is desired at the wall sensor.
11. The 460-v units using an internal secondary pump will require a neutral wire from the supply side in order to feed the accessory with 265-v.

### WSHP OPEN CONTROL

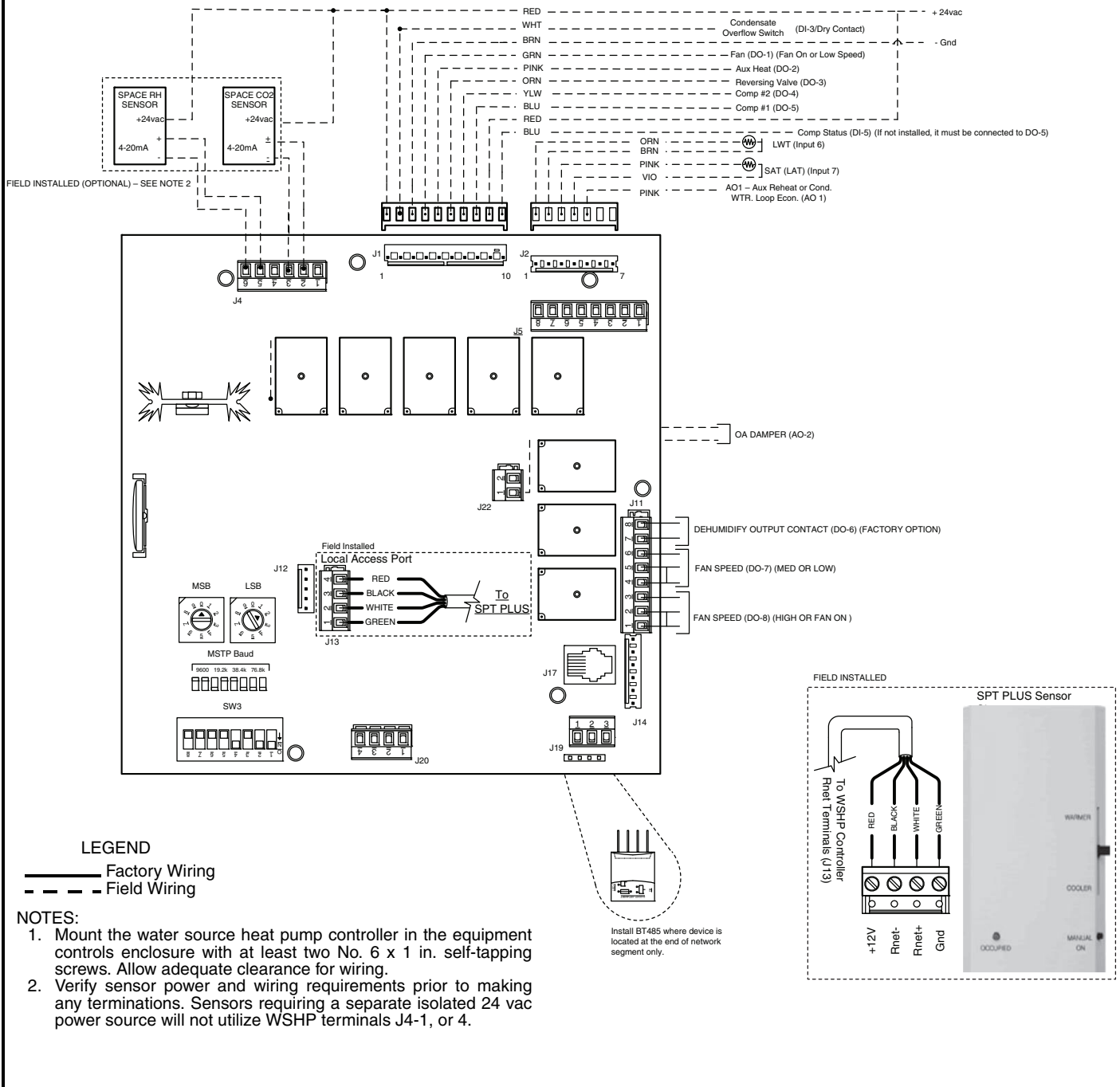

- RED - Condensate Overflow Switch (DI-3/Dry Contact)
- WHT - +24vac
- BRN - Gnd
- GRN - Fan (DO-1) (Fan On or Low Speed)
- PINK - Aux Heat (DO-2)
- ORN - Reversing Valve (DO-3)
- YLV - Comp #2 (DO-4)
- BLU - Comp #1 (DO-5)
- RED - Comp Status (DI-5) (If not installed, it must be connected to DO-5)
- BLU - LWT (Input 6)
- ORN - SAT (LAT) (Input 7)
- BRN - AO1 - Aux Reheat or Cond. WTR. Loop Econ. (AO 1)
- PINK - PINK
- VIO - PINK

**LEGEND**  
 ——— Factory Wiring  
 - - - - - Field Wiring

- NOTES:**
1. Mount the water source heat pump controller in the equipment controls enclosure with at least two No. 6 x 1 in. self-tapping screws. Allow adequate clearance for wiring.
  2. Verify sensor power and wiring requirements prior to making any terminations. Sensors requiring a separate isolated 24 vac power source will not utilize WSHP terminals J4-1, or 4.

Install BT485 where device is located at the end of network segment only.

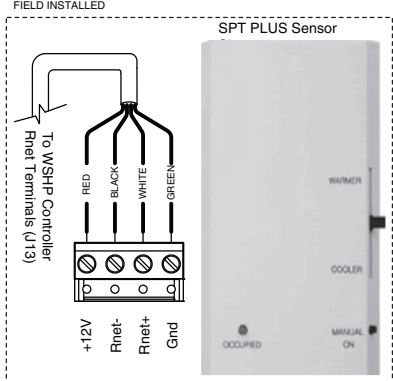

# Typical control wiring schematics (cont)



## PREMIERLINK™ CONTROLLER APPLICATIONS WITH COMPLETE C CONTROL

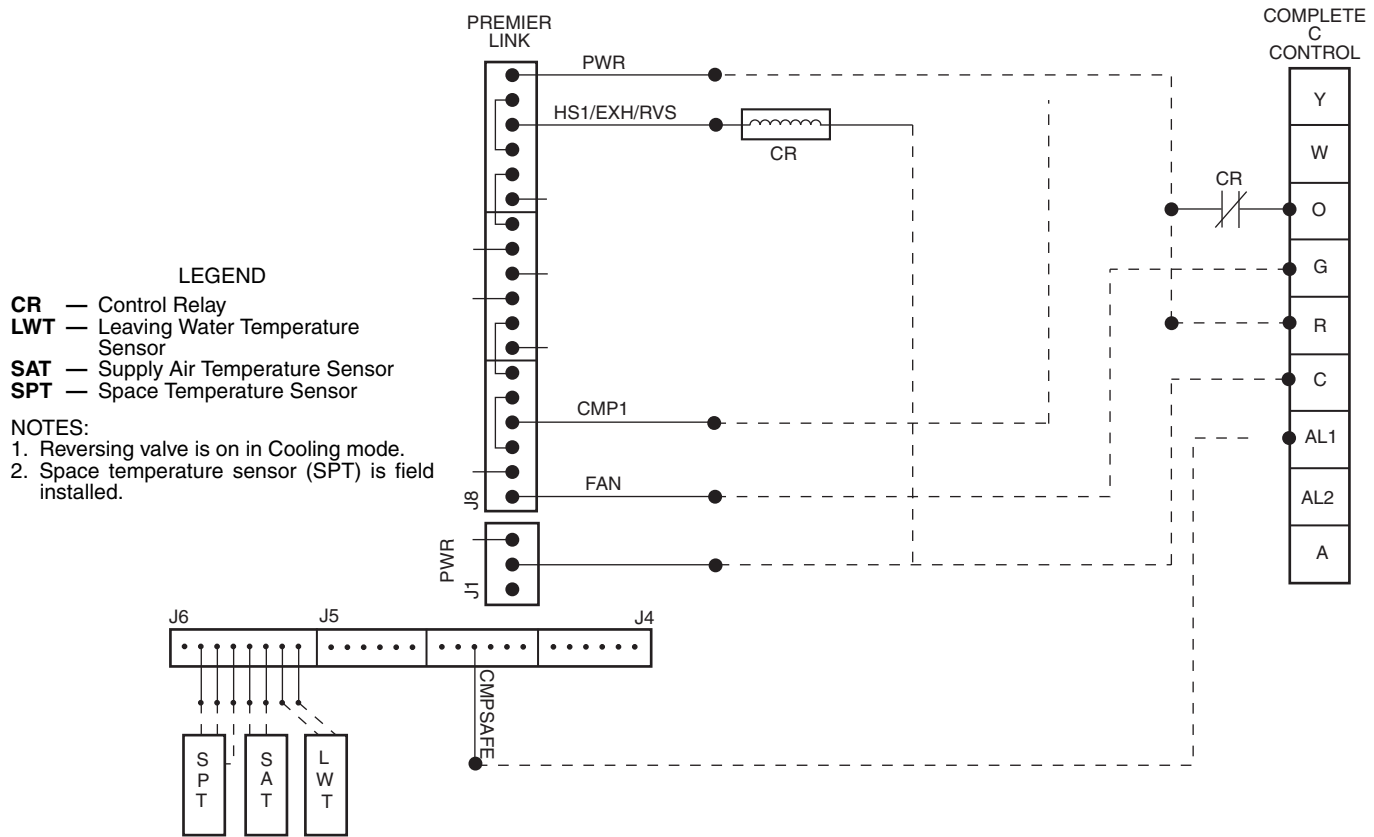

## PREMIERLINK CONTROLLER APPLICATIONS WITH DELUXE D CONTROL

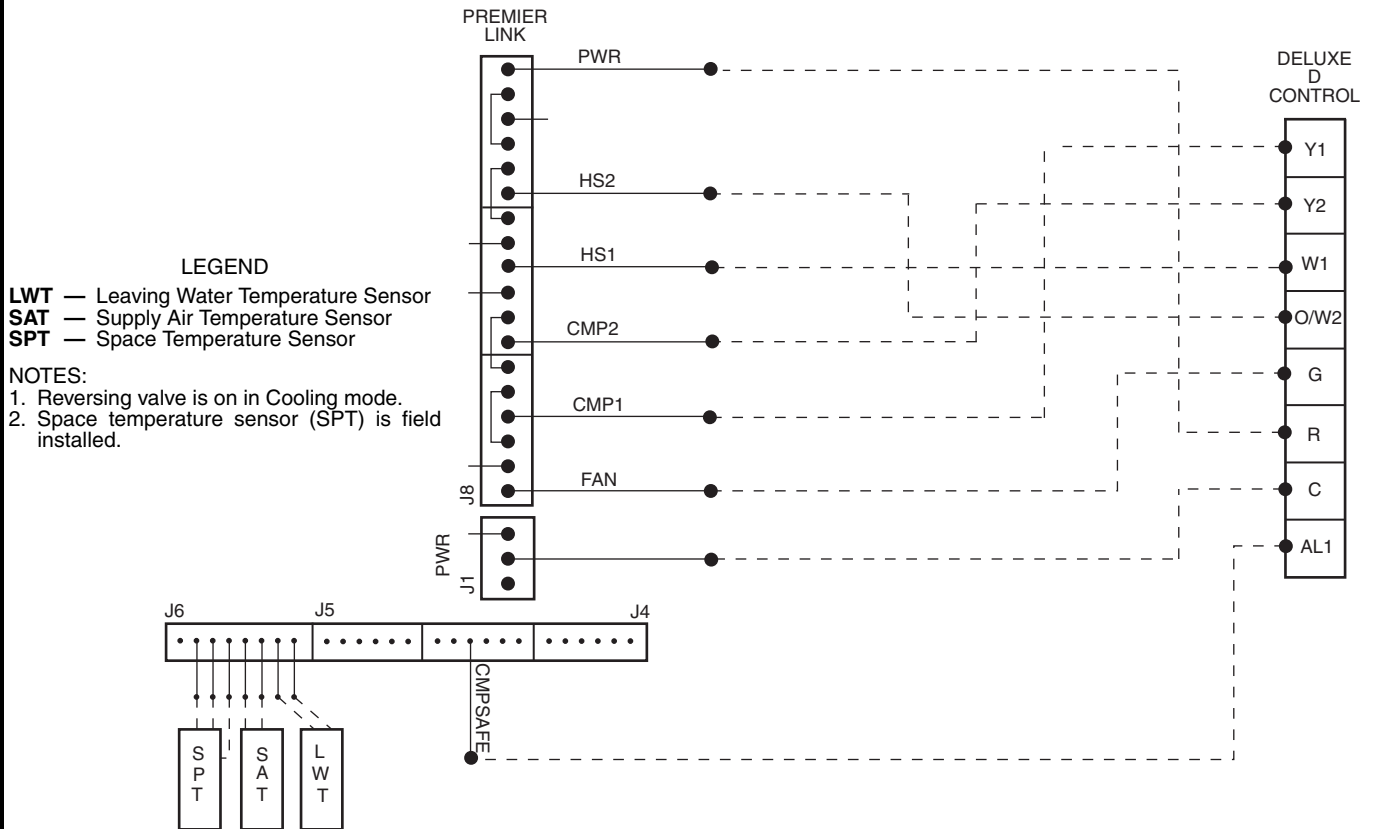

# Application data



Aquazone™ water source heat pumps are available in a flexible, efficient array of models, which can be used in all types of water loop, ground water, and ground loop type systems. Aquazone products provide optimal energy efficient solutions and adapt to the most challenging design requirements.

## AQUAZONE PRODUCT GUIDE

50 SERIES	TYPE SIZE (tons)	APPLICATION
50HQP,VQP	Large Capacity 6-10 (HQP) 6 1/2-25 (VQP)	Environmentally sound unit with Puron® refrigerant (R-410A) designed to handle large zoned areas for all geothermal and boiler/tower applications.
50PC	Compact 1/2-5	Compact WSHP with Puron refrigerant (R-410A) for boiler/tower, ground water, or ground loop systems.
50PS	Premium Efficiency 1/2-6	Premium, ultra efficient unit with Puron refrigerant (R-410A) for boiler/tower, ground water, or ground loop systems
50PEC	High Efficiency Console 3/4-1 1/2	Efficient console unit with Puron refrigerant (R-410A) and attractive design for finished interior, under-window installations.
50PT	Premium Efficiency 2-6	Premium, ultra efficient 2-stage unit with Puron refrigerant (R-410A) for new boiler/tower, ground water, or ground loop systems
50PSW	Water-to-Water 3-28	Efficient unit with Puron refrigerant (R-410A) serves as an alternative to pre-heat or cool air. Unit can be used as a stand-alone or supplemental boiler/chiller in most hydronic heating applications. Also conditions process fluids, lubricants, and refrigerants.
50RTP	Rooftop 3-20	Economical solution for indoor air quality (IAQ) problems and tempering ventilation air.
50VS	Premium Efficiency Vertical Stack Heat Pump 3/4 to 3 Tons	Ultra efficient unit with environmentally sound Puron refrigerant (R-410A) for boiler/tower and geothermal applications (condominiums, hotels, etc.). Stacked design allows for common piping and simplistic design.

## Water loop system

Water loop (or boiler/tower) system applications typically include a number of units plumbed to a common piping system. For optimal performance, this system should be designed between 2.25 and 3 gpm per ton of cooling capacity. The system is comprised of highly efficient packaged reverse cycle heat pump units interconnected by a water loop. The water circuit serves as both a sink and source for heat absorption and rejection and is designed for entering water temperatures between 60 and 90 F. Within this temperature range units can heat or cool as required from the same water source. Transferring heat from warm to cold spaces in the building, whenever they coexist, conserves energy rather than creating new heat.

Refer to the **Carrier Water Source Heat Pump System Design Guide** for assistance designing water loop systems. The guide includes a practical approach for the most current design recommendations including:

- Product application including horizontal, vertical, console, rooftop and water-to-water applications.
- Ventilation methods and system design including energy recovery.
- Acoustical considerations for different product types.
- Addressing indoor air quality (IAQ) issues such as condensate removal, humidity control.
- Air distribution design including diffuser selection/layout and ductwork design.

- Hydronic system design including pipe sizing/layout and boiler/tower sizing.
- Control configurations such as stand alone, DDC, DCV, and VVT® controls.
- Water Source Heat Pump Efficiency/Operational Cost Comparison chart.
- System variations such as a system without a boiler, variable pumping, and VAV for interior use.

## Condensate drainage

**Venting** — Properly vent condensate lines to prevent fan pressure from causing water to hang up in the piping. Condensate lines should be pitched to assure full drainage of condensate under all load conditions. Use chemical treatment to remove algae in the condensate pans and drains in geographical areas that are conducive to algae growth.

**Trapping** — Condensate trapping is a necessity on every water source heat pump unit. A trap is provided to prevent the backflow of moisture from the condensate pan and into the fan intake or downstream into the mechanical system. The water seal or the length of the trap depends on the positive or negative pressure on the drain pan. As a rule of thumb, size the water seal 1 in. for every 1 in. of negative pressure on the unit. The water seal is the distance from the bottom of the unit condensate piping connection to the bottom of the condensate drain line run-out piping. Therefore, the trap size should be double the water seal dimension.

**Horizontal units** — Horizontal units should be sloped toward the drain at a 1/4 in. per foot pitch. If it is not possible to meet the pitch requirement, a condensate pump should be designed and installed at the unit to pump condensate to a building drain. Horizontal units are not internally trapped; therefore an external trap is necessary. Each unit must be installed with its own individual trap and means to flush or blow out the condensate drain. It is not acceptable to use a common trap or vent for multiple units. The condensate piping system should not be designed with a pipe size smaller than the drain connection pipe size.

**Vertical units** — Vertical units use a condensate hose inside the cabinet that acts as a trapping loop, making an external trap unnecessary. Install each unit with its own vent and means to flush or blow out the condensate drain lines. Do not install a common trap or vent on vertical units.

## Water conditioning

In some applications, maintaining proper water quality may require higher corrosion protection for the water-to-refrigerant heat exchanger. Water quality varies from location to location and is unique for each job. Water characteristics such as pH value, alkalinity, hardness, and specific conductance are important when considering any WSHP application. Water typically includes impurities and hardness that must be removed. The required treatment will depend on the water quality as well as type of system. Water problems fall into three main categories:

1. Scale formation caused by hard water reduces the heat transfer rate and increases the water pressure drop through the heat exchanger. As water is heated, minerals and salts are precipitated from a solution

# Application data (cont)



and deposited on the inside surface of the pipe or tube.

- Corrosion is caused by absorption of gases from the air coupled with water on exposed metal. Corrosion is also common in salt-water areas.
- Organic growths such as algae can reduce the heat transfer rate by forming an insulating coating on the

inside tube surface. Algae can also promote corrosion by pitting.

NOTE: In most commercial water loop applications, Aqua-zone WSHP units use copper water-to-refrigerant heat exchanger. Units can also be equipped with a cupronickel heat exchanger for applications where water is outside the standard contaminant limits for a copper heat exchanger.

## COMPLETE C AND DELUXE D ELECTRONIC CONTROL FEATURES COMPARISON

FEATURES	COMPLETE C	COMPLETE C WITH LON	DELUXE D	DELUXE D WITH LON	COMPLETE C OR DELUXE D WITH WSHP OPEN CONTROLLER
<b>BASIC FEATURES</b>					
High and Low Refrigerant Pressure Protection	S	S	S	S	S
Water Coil Freeze Protection	S	S	S	S	S
True 24 VA Thermostat Signals	S	S	S	S	S
Thermostat Inputs Compatible with Triacs	S	S	S	S	S
Condensate Overflow Sensor	S	S	S	S	S
Anti-Short-Cycle Time Delay	S	S	S	S	S
Random Start	S	S	S	S	S
Alarm (selectable dry contact or 24 VA)	S	S	S	S	S
Water Valve Relay	S	S	S	S	S
Water Valve Relay with Compressor Delay	N/A	N/A	S	S	S
Emergency Shutdown	N/A	DDC	S	DDC	DDC
Night Setback with Override	N/A	DDC	S	DDC	DDC
Outdoor Air Damper Control	N/A	N/A	S	S	S
<b>ADVANCED FEATURES</b>					
Intelligent Reset	S	S	S	S	S
High and Low Voltage Protection	S	S	S	S	S
Air Coil Freeze Protection	S	S	S	S	S
Freeze Set Point Field Select (water, antifreeze)	S	S	S	S	S
Electric Heat Control Outputs	S	S	S	S	S
Boilerless Electric Heat Control	N/A	N/A	S	S	S
Intelligent Reversing Valve Operation	N/A	DDC	S	S	S
High/Low Fan Speed Outputs	N/A	N/A	S	S	S
Intelligent Fan Speed Control	N/A	N/A	S	S	S
Thermostat Type Select (Y,O or Y,W)	N/A	N/A	S	N/A	N/A
Reversing Valve Signal Select (O or B)	N/A	N/A	S	N/A	N/A
Dehumidistat Input	N/A	N/A	S	S	S
Reheat Dehumidification Control	N/A	N/A	O	O	O
Multiple Units on One Thermostat/Wall Sensor	N/A	DDC	S	DDC	DDC
Condenser Waterside/Airside Linkage	N/A	N/A	N/A	N/A	S
Waterside Economizer	N/A	N/A	N/A	N/A	S
Proactive Diagnostics	N/A	N/A	N/A	N/A	S
CO <sub>2</sub> Sensor Capable	N/A	N/A	N/A	N/A	S
IAQ Capable	N/A	N/A	N/A	N/A	S
<b>SERVICE AND RELIABILITY FEATURES</b>					
Service Test Mode	S	S	S	S	S
LED Fault and Status Lights	S	S	S	S	S
Fault Memory After Reset	S	S	S	S	S
Unit Performance Sentinel	S	S	S	S	S
Harness-Type Factory Wiring Connections	S	S	S	S	S
Fully Noise-Tested Design	S	S	S	S	S
CE Approval	S	S	S	S	S
Removable Low Voltage Connector	N/A	N/A	S	S	S
<b>DDC/ENERGY MANAGEMENT FEATURES</b>					
LONMark Compliant	N/A	S	N/A	S	S
BACnet Compliant	N/A	N/A	N/A	N/A	S
Johnson N2 Compliant	N/A	N/A	N/A	N/A	S
Modbus Compliant	N/A	N/A	N/A	N/A	S
Leaving Air and Water Temperature Sensor	N/A	S	N/A	S	S
Digital Wall Sensor	N/A	O	N/A	O	O

### LEGEND

Complete C — Complete C Control System  
 DDC — Direct Digital Controls  
 Deluxe D — Deluxe D Control System  
 IAQ — Indoor Air Quality

LON — LONMark Controller  
 N/A — Not Available  
 O — Optional  
 S — Standard



## WATER QUALITY GUIDELINES

CONDITION	HX MATERIAL*	CLOSED RECIRCULATING†	OPEN LOOP AND RECIRCULATING WELL**
<b>Scaling Potential — Primary Measurement</b>			
Above the given limits, scaling is likely to occur. Scaling indexes should be calculated using the limits below.			
pH/Calcium Hardness Method	All	N/A	pH < 7.5 and Ca Hardness, <100 ppm
<b>Index Limits for Probable Scaling Situations (Operation outside these limits is not recommended.)</b>			
Scaling indexes should be calculated at 150 F for direct use and HWG applications, and at 90 F for indirect HX use. A monitoring plan should be implemented.			
Ryznar Stability Index	All	N/A	<b>6.0 - 7.5</b> If >7.5 minimize steel pipe use.
Langelier Saturation Index	All	N/A	<b>-0.5 to +0.5</b> If <-0.5 minimize steel pipe use. Based upon 150 F HWG and direct well, 85 F indirect well HX.
<b>Iron Fouling</b>			
Iron Fe <sup>2+</sup> (Ferrous) (Bacterial Iron Potential)	All	N/A	<b>&lt;0.2 ppm (Ferrous)</b> If Fe <sup>2+</sup> (ferrous) >0.2 ppm with pH 6 - 8, O <sub>2</sub> <5 ppm check for iron bacteria.
Iron Fouling	All	N/A	<b>&lt;0.5 ppm of Oxygen</b> Above this level deposition will occur.
<b>Corrosion Prevention††</b>			
pH	All	6 - 8.5 Monitor/treat as needed.	<b>6 - 8.5</b> Minimize steel pipe below 7 and no open tanks with pH <8.
Hydrogen Sulfide (H <sub>2</sub> S)	All	N/A	<b>&lt;0.5 ppm</b> At H <sub>2</sub> S>0.2 ppm, avoid use of copper and cupronickel piping or HXs. Rotten egg smell appears at 0.5 ppm level. Copper alloy (bronze or brass) cast components are okay to <0.5 ppm.
Ammonia Ion as Hydroxide, Chloride, Nitrate and Sulfate Compounds	All	N/A	<b>&lt;0.5 ppm</b>
Maximum Chloride Levels	Maximum allowable at maximum water temperature.		
			50 F (10 C)      75 F (24 C)      100 F (38 C)
	Copper	N/A	<20 ppm      NR      NR
	Cupronickel	N/A	<150 ppm      NR      NR
304 SS	N/A	<400 ppm      <250 ppm      <150 ppm	
316 SS	N/A	<1000 ppm      <550 ppm      <375 ppm	
Titanium	N/A	>1000 ppm      >550 ppm      >375 ppm	
<b>Erosion and Clogging</b>			
Particulate Size and Erosion	All	<10 ppm of particles and a maximum velocity of 6 fps. Filtered for maximum 800 micron size.	<10 ppm (<1 ppm "sandfree" for reinjection) of particles and a maximum velocity of 6 fps. Filtered for maximum 800 micron size. Any particulate that is not removed can potentially clog components.
Brackish	All	N/A	Use cupronickel heat exchanger when concentrations of calcium or sodium chloride are greater than 125 ppm are present. (Seawater is approximately 25,000 ppm.)

### LEGEND

- HWG** — Hot Water Generator
- HX** — Heat Exchanger
- N/A** — Design Limits Not Applicable Considering Recirculating Potable Water
- NR** — Application Not Recommended
- SS** — Stainless Steel

\*Heat exchanger materials considered are copper, cupronickel, 304 SS (stainless steel), 316 SS, titanium.

†Closed recirculating system is identified by a closed pressurized piping system.

\*\*Recirculating open wells should observe the open recirculating design considerations.

††If the concentration of these corrosives exceeds the maximum allowable level, then the potential for serious corrosion problems exists.

Sulfides in the water quickly oxidize when exposed to air, requiring that no agitation occur as the sample is taken. Unless tested immediately at the site, the sample will require stabilization with a few drops of one Molar zinc acetate solution, allowing accurate sulfide determination up to 24 hours after sampling. A low pH and high alkalinity cause system problems, even when both values are within ranges shown. The term pH refers to the acidity, basicity, or neutrality of the water supply. Below 7.0, the water is considered to be acidic. Above 7.0, water is considered to be basic. Neutral water contains a pH of 7.0.

To convert ppm to grains per gallon, divide by 17. Hardness in mg/l is equivalent to ppm.

# Application data (cont)



## Acoustical design

Sound power levels represent the sound produced by the source, the WSHP unit, with no regard to attenuation between the source and the space. Acoustical design goals are necessary to provide criteria for occupied spaces. These goals help ensure that people are comfortable and can communicate effectively over the air conditioning system and other background noise sources.

Acoustical design goals are desirable sound pressure levels within a given conditioned space and are represented by noise criteria (NC) curves. Noise criteria curve levels represent a peak over a full spectrum of frequencies. A high value in a low frequency band has the same effect on NC level as a lower value in a high frequency band. It is important that sound levels be balanced over the entire spectrum relative to the NC curve. The lower the NC criteria curve, the more stringent the room acoustical design must be to meet the design goals.

It is important to know how to convert the unit ratings from sound power (Lw) to sound pressure (Lp). This conversion depends on the specifics of the installation's acoustic environment.

Assessing an area's acoustical design means comparing the sound pressure (Lp) with the NC curve for the selected area.

Some of the factors that affect conversion of sound power to sound pressure and consequent NC level include:

- Type of acoustical ceiling
- Use of metal or flex duct
- Absorption in the occupied space
- Location in the occupied space
- Open or closed layout plan
- Use of open or ducted returns
- Orientation of unit to occupant
- Use of lined or unlined duct

**OCTAVE BAND SOUND PRESSURE LEVEL (Lp)  
ASSOCIATED WITH NC CURVES**

NOISE CRITERIA CURVES	OCTAVE BAND SOUND PRESSURE LEVEL (Lp)							
	Frequency (Hz)							
	63	125	250	500	1000	2000	4000	8000
NC-15	49	36	26	17	17	14	12	11
NC-20	52	41	33	27	22	19	17	16
NC-25	54	45	38	31	27	24	22	21
NC-30	58	49	41	36	31	29	28	27
NC-35	61	53	45	40	36	34	33	32
NC-40	64	57	50	45	41	39	38	37
NC-45	67	61	54	49	46	44	43	42
NC-50	71	64	58	54	51	49	48	47
NC-55	74	68	63	58	56	54	53	52
NC-60	77	71	67	63	61	59	58	57
NC-65	80	75	71	68	66	64	63	62

**Equipment selection** — If the unit will be used for space cooling, a unit with at least enough capacity to satisfy the building sensible load should be selected. If the latent cooling load is not satisfied by the selection, a larger unit with enough latent capacity will be required. If the unit will be used for dehumidification purposes only, the latent capacity is the only necessary consideration.

NOTE: In some cases, the high-static option may be required for applications with higher static ductwork, as the reheat coil adds a small amount of resistance to the air stream.

## Sound control

Analyzing the projected sound level in the conditioned space caused by a WSHP unit located in a ceiling plenum is quite involved. The key is to have good sound power ratings (Lw) in dB on the equipment to determine the sound attenuation effect of the ductwork, ceiling and room. Aquazone™ equipment includes standard attenuating features and offers an advanced mute package. In addition, suggestions for unit sound design around the WSHP can be provided.

## Horizontal units

Use the following guidelines for layout of Aquazone™ horizontal units to minimize noise:

1. To select quietest equipment, obtain sound power ratings in accordance with latest standards from manufacturers.
2. Do not locate units over a space with a required noise criteria of 40 or less. Instead, locate units above less sensitive noise areas such as above or in equipment rooms, utility closets, restrooms, storage rooms, or above corridors.
3. Provide at least 10 ft between WSHP units to avoid the additive effect of two noise sources.
4. Provide an acoustical pad underneath the WSHP unit in applications where the unit must be mounted above noise sensitive areas such as private offices or conference rooms. The pad attenuates radiated noise. Be sure the pad has an area at least twice that of the WSHP footprint.
5. Maximize the installed height above the suspended ceiling.
6. Be sure the WSHP unit is located at least 6 ft away from any ceiling return grille to prevent line-of-sight casing noise to reach the space below.
7. Suspend horizontal WSHP unit from the ceiling with hangers that use spring or neoprene type isolators to reduce vibration transmission.
8. Use flexible electrical connections to the WSHP unit. **DO NOT USE RIGID CONNECTIONS.**
9. Use flexible loop water and condensate piping connections to the WSHP unit.
10. Use a canvas duct connector to connect the WSHP discharge flange to the downstream duct system to reduce vibration-induced noise.
11. Provide acoustic interior lining for the first 20 ft of discharge duct, or until the first elbow is reached. The elbow prevents line-of-site sound transmission in the discharge duct.
12. Provide turning vanes in ductwork elbows and tees to reduce air turbulence.
13. Size the sheet metal supply duct with velocities no greater than 1000 fpm.





14. Ensure ductwork is rigid.
15. Use round ducts whenever possible to further reduce noise.
16. Allow at least 3 equivalent duct diameters of straight duct upstream and downstream of the unit before allowing any fittings, transitions, etc.
17. Seal all penetrations around duct entering the space.
18. Provide a 4-ft run-out duct made of flexible material to connect a diffuser to the supply trunk duct. The flex duct provides an “attenuating end-effect” and reduces duct-transmitted sound before it reaches the space. Flex ductwork typically reduces sound by 6 dB.
19. Locate the run-out duct balancing damper as far away from the outlet diffuser as possible. Locating the balancing damper at the trunk duct exit is best.
20. If return air is drawn through a ceiling plenum, provide an acoustically lined return duct elbow or “L” shaped boot at the WSHP to eliminate line-of-sight noise into the ceiling cavity and possibly through the ceiling return air grilles. Face the elbow or boot away from the nearest adjacent WSHP unit to prevent additive noise.
21. Do not hang suspended ceiling from the ductwork.

### **Vertical units**

All guidelines established for horizontal units also apply for vertical units. In addition, since vertical units tend to be installed in small equipment rooms or closets, the following additional guidelines apply:

1. Mount the unit on a pad made of high-density sound absorbing material such as rubber or cork. Extend the pad beyond the WSHP unit footprint by at least 6 inches in each direction.

2. Since the unit returns airflow through a grille mounted in a closet door, provide a sound barrier or some other modification of the closet to prevent line-of-sight noise into the conditioned space.
3. Follow good duct design practice in sizing and locating the connection of the WSHP discharge to the supply duct system. Use an elbow with turning vanes bent in the direction of the fan rotation to minimize turbulence. Make any duct transitions as smooth and gradual as possible to further minimize turbulence and loss of fan static pressure.

### **Solenoid valves**

In applications using variable flow pumping, solenoid valves can be field installed and operated from the control board in the Aquazone WSHP unit.

### **Freeze protection**

Applications where systems are exposed to outdoor temperatures below freezing (32 F) must be protected from freezing. The most common method of protecting water systems from freezing is adding glycol concentrations into the water. Use design care when selecting both the type and concentrations of glycol due to the following:

- Equipment and performance may suffer with high concentrations of glycol and other antifreeze solutions.
- Loss of piping pressure may increase greatly, resulting in higher pumping costs.
- Higher viscosity of the mixture may cause excess corrosion and wear on the entire system.
- Acidity of the water may be greatly increased, promoting corrosion.
- Glycol promotes galvanic corrosion in systems of dissimilar metals. The result is corrosion of one metal by the other, causing leaks.

## WSHP Open sequence of operation

The WSHP Open multi-protocol controller will control mechanical cooling, heating and waterside economizer outputs based on its own space temperature input and set points. An optional CO<sub>2</sub> IAQ (indoor air quality) sensor mounted in the space can maximize the occupant comfort. The WSHP Open controller has its own hardware clock that is automatically set when the heat pump software is downloaded to the board. Occupancy types are described in the scheduling section below. The following sections describe the functionality of the WSHP Open multi-protocol controller. All point objects referred to in this sequence of operation will be referenced to the objects as viewed in the BACview<sup>6</sup> handheld user interface.

**Scheduling** — Scheduling is used to start/stop the unit based on a time period to control the space temperature to specified occupied heating and cooling set points. The controller is defaulted to control by occupied set points all the time, until either a time schedule is configured with BACview<sup>6</sup>, Field Assistant, i-Vu<sup>®</sup> Open, or a third party control system to enable/disable the BAS (Building Automation System) on/off point. The local time and date must be set for these functions to operate properly. The occupancy source can be changed to one of the following:

**Occupancy schedules** — The controller will be occupied 24/7 until a time schedule has been configured using either Field Assistant, i-Vu Open, BACview<sup>6</sup> or a third party control system to enable/disable the BAS on/off point. The BAS point can be disabled by going to Config, then Unit, then Occupancy Schedules and changing the point from enable to disable then clicking OK.

NOTE: This point must be enabled in order for the i-Vu Open, Field Assistant, or BACview<sup>6</sup> control system to assign a time schedule to the controller.

**Schedule\_schedule** — The unit will operate according to the schedule configured and stored in the unit. The schedule is accessible via the BACview<sup>6</sup> Handheld tool, i-Vu Open, or Field Assistant control system. The daily schedule consists of a start/stop time (standard or 24-hour mode) and seven days of the week, starting with Monday and ending on Sunday. To enter a daily schedule, navigate to Config, then Sched, then enter BACview<sup>6</sup> Admin Password (1111), then go to schedule\_schedule. From here, enter either a Weekly or Exception schedule for the unit.

**Occupancy input contact** — The WSHP Open controller has the capability to use an external dry contact closure to determine the occupancy status of the unit. The Occupancy Schedules will need to be disabled in order to utilize the occupancy contact input.

NOTE: Scheduling can only be controlled from one source.

**BAS (Building Automation System) on/off** — A BAS system that supports network scheduling can control the unit through a network communication and the BAS scheduling function once the Occupancy Schedules have been disabled.

NOTE: Scheduling can either be controlled via the unit or the BAS, but not both.

**Indoor fan** — The indoor fan will operate in any one of three modes depending on the user configuration selected.

Fan mode can be selected as Auto, Continuous, or Always On. In Auto mode, the fan is in intermittent operation during both occupied and unoccupied periods. Continuous fan mode is intermittent during unoccupied periods and continuous during occupied periods. Always On mode operates the fan continuously during both occupied and unoccupied periods. In the default mode, Continuous, the fan will be turned on whenever any one of the following is true:

- The unit is in occupied mode as determined by its occupancy status.
- There is a demand for cooling or heating in the unoccupied mode.
- There is a call for dehumidification (optional).

When power is reapplied after a power outage, there will be a configured time delay of 5 to 600 seconds before starting the fan. There are also configured fan delays for Fan On and Fan Off. The Fan On delay defines the delay time (0 to 30 seconds; default 10) before the fan begins to operate after heating or cooling is started while the Fan Off delay defines the delay time (0 to 180 seconds; default 45) the fan will continue to operate after heating or cooling is stopped. The fan will continue to run as long as the compressors, heating stages, or the dehumidification relays are on. If the SPT failure alarm or condensate overflow alarm is active; the fan will be shut down immediately regardless of occupancy state or demand.

**Fan speed control (during heating)** — Whenever heat is required and active, the control continuously monitors the supply-air temperature to verify it does not rise above the configured maximum heating SAT limit (110 F default). As the SAT approaches this value, the control will increase the fan speed as required to ensure the SAT will remain within the limit. This feature provides the most quiet and efficient operation by operating the fan at the lowest speed possible.

**Fan speed control (during cooling)** — Whenever mechanical cooling is required and active, the control continuously monitors the supply-air temperature to verify it does not fall below the configured minimum cooling SAT limit (50 F default). As the SAT approaches this value, the control will increase the fan speed as required to ensure the SAT will remain within the limit. The fan will operate at lowest speed to maximize latent capacity during cooling.

**Cooling** — The WSHP Open controller will operate one or two stages of compression to maintain the desired cooling set point. The compressor outputs are controlled by the PI (proportional-integral) cooling loop and cooling stages capacity algorithm. They will be used to calculate the desired number of stages needed to satisfy the space by comparing the space temperature (SPT) to the appropriate cooling set point. The water side economizer, if applicable, will be used for first stage cooling in addition to the compressor(s). The following conditions must be true in order for the cooling algorithm to run:

- Cooling is set to Enable.
- Heating mode is not active and the compressor time guard has expired.

- Condensate overflow input is normal.
- If occupied, the SPT is greater than the occupied cooling set point.
- Space temperature reading is valid.
- If unoccupied, the SPT is greater than the unoccupied cooling set point.
- If economizer cooling is available and active and the economizer alone is insufficient to provide enough cooling.
- OAT (if available) is greater than the cooling lockout temperature.

If all the above conditions are met, the compressors will be energized as required, otherwise they will be deenergized. If cooling is active and should the SAT approach the minimum SAT limit, the fan will be indexed to the next higher speed. Should this be insufficient and if the SAT falls further (equal to the minimum SAT limit), the fan will be indexed to the maximum speed. If the SAT continues to fall 5° F below the minimum SAT limit, all cooling stages will be disabled.

During Cooling mode, the reversing valve output will be held in the cooling position (either B or O type as configured) even after the compressor is stopped. The valve will not switch position until the Heating mode is required.

The configuration screens contain the minimum SAT parameter as well as cooling lockout based on outdoor-air temperature (OAT). Both can be adjusted to meet various specifications.

There is a 5-minute off time for the compressor as well as a 5-minute time delay when staging up to allow the SAT to achieve a stable temperature before energizing a second stage of capacity. Likewise, a 45-second delay is used when staging down.

After a compressor is staged off, it may be restarted again after a normal time-guard period of 5 minutes and if the supply-air temperature has increase above the minimum supply-air temperature limit.

The WSHP Open controller provides a status input to monitor the compressor operation. The status is monitored to determine if the compressor status matches the commanded state. This input is used to determine if a refrigerant safety switch or other safety device has tripped and caused the compressor to stop operating normally. If this should occur, an alarm will be generated to indicate the faulted compressor condition.

**Heating** — The WSHP Open controller will operate one or two stages of compression to maintain the desired heating set point. The compressor outputs are controlled by the heating PI (proportional-integral) loop and heating stages capacity algorithm. They will be used to calculate the desired number of stages needed to satisfy the space by comparing the space temperature (SPT) to the appropriate heating set point. The following conditions must be true in order for the heating algorithm to run:

- Heating is set to Enable.
- Cooling mode is not active and the compressor time guard has expired.
- Condensate overflow input is normal.

- If occupied, the SPT is less than the occupied heating set point.
- Space temperature reading is valid.
- If unoccupied, the SPT is less than the unoccupied heating set point.
- OAT (if available) is less than the heating lockout temperature.

If all the above conditions are met, the heating outputs will be energized as required, otherwise they will be deenergized. If the heating is active and should the SAT approach the maximum SAT limit, the fan will be indexed to the next higher speed. Should this be insufficient, and the SAT rises further reaching the maximum heating SAT limit, the fan will be indexed to the maximum speed. If the SAT still continues to rise 5° F above the maximum limit, all heating stages will be disabled.

During Heating mode, the reversing valve output will be held in the heating position (either B or O type as configured) even after the compressor is stopped. The valve will not switch position until the Cooling mode is required.

The configuration screens contain the maximum SAT parameter as well as heating lockout based on outdoor-air temperature (OAT); both can be adjusted to meet various specifications.

There is a 5-minute off time for the compressor as well as a 5-minute time delay when staging up to allow the SAT to achieve a stable temperature before energizing a second stage of capacity. Likewise, a 45-second delay is used when staging down.

After a compressor is staged off, it may be restarted again after a normal time-guard period of 5 minutes and if the supply-air temperature has fallen below the maximum supply air temperature limit.

The WSHP Open controller provides a status input to monitor the compressor operation. The status is monitored to determine if the compressor status matches the commanded state. This input is used to determine if a refrigerant safety switch or other safety device has tripped and caused the compressor to stop operating normally. If this should occur, an alarm will be generated to indicate the faulted compressor condition. Also, if auxiliary heat is available (see below), the auxiliary heat will operate to replace the reverse cycle heating and maintain the space temperature as required.

**Auxiliary heat** — The WSHP Open controller can control a two-position, modulating water, or steam valve connected to a coil on the discharge side of the unit and supplied by a boiler or a single-stage ducted electric heater in order to maintain the desired heating set point. Should the compressor capacity be insufficient or a compressor failure occurs, the auxiliary heat will be used. Unless the compressor fails, the auxiliary heat will only operate to supplement the heat provided by the compressor if the space temperature falls more than one degree below the desired heating set point (the amount is configurable). The heat will be controlled so the SAT will not exceed the maximum heating SAT limit.

# Controls (cont)



Auxiliary modulating hot water/steam heating reheat — The control can modulate a hot water or steam valve connected to a coil on the discharge side of the unit and supplied by a boiler in order to maintain the desired heating set point should the compressor capacity be insufficient or a compressor failure occurs. Unless a compressor fault condition exists, the valve will only operate to supplement the heat provided by the compressor if the temperature falls more than one degree below the desired heating set point. The valve will be controlled so the SAT will not exceed the maximum heating SAT limit.

Two-position hot water/steam heating reheat — The control can operate a two-position, NO or NC, hot water or steam valve connected to a coil on the discharge side of the unit and supplied by a boiler in order to maintain the desired heating set point should the compressor capacity be insufficient or a compressor failure occurs. Unless a compressor fault condition exists, the valve will only open to supplement the heat provided by the compressor if the space temperature falls more than one degree below the desired heating set point. The valve will be controlled so the SAT will not exceed the maximum heating SAT limit. The heat stage will also be subject to a 2-minute minimum OFF time to prevent excessive valve cycling.

Single stage electric auxiliary heat — The control can operate a field-installed single stage of electric heat installed on the discharge side of the unit in order to maintain the desired heating set point should the compressor capacity be insufficient or a compressor failure occurs. Unless a compressor fault condition exists, the heat stage will only operate to supplement the heat provided by the compressor if the space temperature falls more than one degree below the desired heating set point. The heat stage will be controlled so the SAT will not exceed the maximum heating SAT limit. The heat stage will also be subject to a 2-minute minimum OFF time to prevent excessive cycling.

**Indoor air quality (IAQ) and demand controlled ventilation (DCV)** — If the optional indoor air quality sensor is installed, the WSHP Open controller can maintain indoor air quality via a modulating OA damper providing demand controlled ventilation. The control operates the modulating OA damper during occupied periods. The control monitors the CO<sub>2</sub> level and compares it to the configured set points, adjusting the ventilation rate as required. The control provides proportional ventilation to meet the requirements of ASHRAE (American Society of Heating, Refrigerating and Air Conditioning Engineers) specifications by providing a base ventilation rate and then increasing the rate as the CO<sub>2</sub> level increases. The control will begin to proportionally increase ventilation when the CO<sub>2</sub> level rises above the start ventilation set point and will reach the full ventilation rate when the CO<sub>2</sub> level is at or above the maximum set point. A user-configurable minimum damper position ensures that proper base ventilation is delivered when occupants are not present. The IAQ configurations can be accessed through the configuration screen. The following conditions must be true in order for this algorithm to run:

- Damper control is configured for DCV.
- The unit is in an occupied mode.

- The IAQ sensor reading is greater than the DCV start control set point.

The control has four user adjustable set points: DCV start control set point, DCV maximum control set point, minimum damper position, and DCV maximum damper position.

Two-position OA damper — The control can be configured to operate a ventilation damper in a two-position ventilation mode to provide the minimum ventilation requirements during occupied periods.

**Waterside economizer** — The WSHP Open controller has the capability of providing modulating or two-position water economizer operation (for a field-installed economizer coil mounted to the entering air side of the unit and connected to the condenser water loop) in order to provide free cooling (or preheating) when water conditions are optimal. Water economizer settings can be accessed through the equipment status screen. The following conditions must be true for economizer operation:

- SAT reading is available.
- EWT reading is available.
- If occupied, the SPT is greater than the occupied cooling set point or less than the occupied heating set point and the condenser water is suitable.
- Space temperature reading is valid.
- If unoccupied, the SPT is greater than the unoccupied cooling set point or less than the unoccupied heating set point and the condenser water is suitable.

Modulating water economizer control — The control has the capability to modulate a water valve to control condenser water flowing through a coil on the entering air side of the unit.

*Cooling* — The purpose is to provide an economizer cooling function by using the water loop when the entering water loop temperature is suitable (at least 5° F below space temperature). If the water loop conditions are suitable, then the valve will modulate open as required to maintain a supply air temperature that meets the load conditions. Should the economizer coil capacity alone be insufficient for a period greater than 5 minutes, or should a high humidity condition occur, then the compressor will also be started to satisfy the load. Should the SAT approach the minimum cooling SAT limit, the economizer valve will modulate closed during compressor operation.

*Heating* — Additionally, the control will modulate the water valve should the entering water loop temperature be suitable for heating (at least 5° F above space temperature) and heat is required. The valve will be controlled in a similar manner except to satisfy the heating requirement. Should the economizer coil capacity alone be insufficient to satisfy the space load conditions for more than 5 minutes, then the compressor will be started to satisfy the load. Should the SAT approach the maximum heating SAT limit, the economizer valve will modulate closed during compressor operation.

Two-position water economizer control — The control has the capability to control a NO or NC, two-position water valve to control condenser water flow through a coil on the entering air side of the unit.

**Cooling** — The purpose is to provide a cooling economizer function directly from the condenser water loop when the entering water loop temperature is suitable (at least 5° F below space temperature). If the optional coil is provided and the water loop conditions are suitable, then the valve will open to provide cooling to the space when required. Should the capacity be insufficient for a period greater than 5 minutes, or should a high humidity condition occur, then the compressor will be started to satisfy the load. Should the SAT reach the minimum cooling SAT limit, the economizer valve will close during compressor operation.

**Heating** — Additionally, the economizer control will open the water valve should the entering water loop temperature be suitable for heating (at least 5° F above space temperature) and heat is required. The valve will be controlled in a similar manner except to satisfy the heating requirement. Should the coil capacity be insufficient to satisfy the space load for more than 5 minutes, then the compressor will be started to satisfy the load. Should the SAT reach the maximum heating SAT limit, the economizer valve will close during compressor operation.

**Demand limit** — The WSHP Open controller has the ability to accept three levels of demand limit from the network. In response to a demand limit, the unit will decrease its heating set point and increase its cooling set point to widen the range in order to immediately lower the electrical demand. The amount of temperature adjustment in response is user adjustable for both heating and cooling and for each demand level. The response to a particular demand level may also be set to zero.

**Condenser water linkage** — The control provides optimized water loop operation using an universal controller (UC) open loop controller. Loop pump operation is automatically controlled by WSHP equipment occupancy schedules, unoccupied demand and tenant override conditions. Positive pump status feedback prevents nuisance fault trips. The condenser water linkage operates when a request for condenser water pump operation is sent from each WSHP to the loop controller. This request is generated whenever any WSHP is scheduled to be occupied, is starting during optimal start (for warm-up or pull down prior to occupancy), there is an unoccupied heating or cooling demand, or a tenant pushbutton override. At each WSHP, the water loop temperature and the loop pump status is given. The WSHP will NOT start a compressor until the loop pumps are running or will shutdown the compressors should the pumps stop. This prevents the WSHP from operating without water flow and thus tripping out on refrigerant pressure, causing a lockout condition. The WSHP Open controller control will prevent this from occurring. Also, the loop controller can be configured to start the pumps only after a configurable number of WSHPs are requesting operation (from 1-"N"). This can be used to prevent starting the entire loop operation for only one WSHP. Meanwhile, the WSHPs will not operate if the loop pump status is off and therefore the WSHP compressor will not run.

# Guide specifications



## Packaged Water Source Heat Pumps

### HVAC Guide Specifications

Size Range: **5,800 to 59,400 Btuh**  
**Cooling Capacity**  
**7,500 to 77,000 Btuh**  
**Heating Capacity**

Carrier Unit: **50PCH, 50PCV**

#### Part 1 — General

##### 1.01 SYSTEM DESCRIPTION

- A. Install water source heat pumps, as indicated on the plans with capacities and characteristics as listed in the schedule and the specifications that follow. Units shall be horizontal or vertical configurations.
- B. Units shall be supplied completely factory built and capable of operation with an entering water temperature range from 60 to 95 F.  
Equivalent units from other manufacturers can be proposed provided approval to bid is given 10 days prior to bid closing.
- C. Units shall be individually packaged with wooden skid covered with protective corner posts and plastic stretch wrapping for maximum protection.

##### 1.02 QUALITY ASSURANCE

- A. All equipment listed in this section must be rated in accordance with AHRI/ASHRAE/ISO 13256-1 performance standard, latest edition, and CSA. The units shall have AHRI/ISO, NRTL, and CSA labels.
- B. All units shall be factory tested under normal operating conditions at nominal water flow rates. This testing shall generate a report card to be shipped with each unit stating performance in both Heating and Cooling modes.
- C. Serial numbers will be recorded by factory and furnished to contractor for ease of unit warranty status. Units that are tested without water flow rates are not acceptable.

#### Part 2 — Product

##### 2.01 EQUIPMENT

- A. General:
  1. The horizontal and vertical heat pumps shall be fabricated from heavy gage galvanized sheet metal with powder coated paint finish on front access panels. All interior surfaces shall be lined with 1/2 in. thick, 1 1/2 lb acoustic type fiberglass insulation. All fiberglass shall be coated and have exposed edges tucked under flanges to prevent the introduction of glass fibers into the airstream. All insulation must meet NFPA 90A, UL-181 (air erosion and mold growth), ASTM-C1071, and ASTM 621 and 622.
  2. Units shall be prewired and precharged in factory.
- B. Unit Cabinet:
  1. Units must be field convertible from side to back or back to side discharge with no additional

parts or unit structure modification. Units will have factory-installed hanger brackets and isolation grommets.

2. Horizontal units shall have one of the following airflow arrangements: right-discharge/left-return; left-discharge/right-return; back-discharge/left-return; or back-discharge/right-return as shown on the plans.
  3. Vertical units shall have one of the following airflow arrangements: left-return/top-discharge, front-return/top-discharge, or right-return/top-discharge. All vertical units will be supplied from the factory internally trapped.
  4. If units with these arrangements are not used, the contractor is responsible for any extra costs incurred by other trades.
  5. Cabinets shall have separate openings and knockouts for entrance of line voltage and low voltage control wiring. Contractor must ensure that units can be easily removed for servicing and coordinate locations of electrical conduit and lights with the electrical contractor.
  6. All units must have a minimum of three access panels for serviceability of compressor compartment. If other arrangements make servicing difficult, the contractor must provide access panels and clear routes to ease service. Architect must approve any changes in layout.
  7. All units must have an insulated panel separating the fan compartment from the compressor compartment.
  8. Units with the compressor in the airstream are not acceptable.
- C. Fan and Motor Assembly:
1. Units rated 60,000 Btuh and under shall have a direct-drive centrifugal fan. The fan motor shall be 3-speed, permanently lubricated, PSC (permanent split capacitor) type with internal thermal overload protection.
  2. Blower shall have inlet rings to allow removal of wheel and motor from one side without removing housing.
  3. Units supplied without permanently lubricated motors must provide external oilers for easy service.
  4. The fan motor shall be isolated from the fan housing by torsionally flexible isolation grommets. The fan and motor assembly must be capable of overcoming the external static pressures as shown on the schedule.
  5. The cfm/static pressure rating of the unit shall be based on a dry coil and a clean filter in place.
- D. Refrigerant Components:
1. All units shall contain a Puron® refrigerant (R-410A) sealed circuit including a high-efficiency Copeland UltraTech™ single-stage rotary compressor (sizes 006 to 018) or scroll



compressor (sizes 024 to 060) designed for heat pump operation, a thermostatic expansion valve for refrigerant metering, an enhanced corrugated aluminum lanced fin and rifled copper tube refrigerant-to-air heat exchanger, reversing valve, coaxial (tube-in-tube) refrigerant-to-water heat exchanger, and safety controls, including a high-pressure switch, low-pressure switch (loss of charge), water coil low temperature sensor, and air coil low temperature sensor.

2. Units shall have a TXV (thermostatic expansion valve) for refrigerant metering, an enhanced aluminum lanced fin and rifled copper tube refrigerant to air heat exchanger, a reversing valve, a coaxial (tube-in-tube) refrigerant-to-water heat exchanger.
3. Refrigerant-to-air heat exchangers shall use corrugated lanced aluminum fins and rifled copper tube construction rated to withstand 625 psig refrigerant working pressure.
4. Refrigerant-to-water heat exchangers shall be of copper inner-water tube and steel refrigerant outer tube design, rated to withstand 625 psig working refrigerant pressure and 500 psig working water pressure. Plate-to-plate heat exchangers cannot be used. Refrigerant-to-water heat exchanger shall be "electro-coated."
5. Units capable for use in standard operating range with entering water temperatures from 60 to 95 F or, if equipped with extended range, 20 to 120 F.
6. Reversing valves shall be four-way solenoid activated refrigerant valves, which shall fail to heating operation should the solenoid fail to function. If the reversing valve solenoid fails to cooling, a low temperature thermostat must be provided to prevent over-cooling an already cold room.

#### E. Drain Pan:

The drain pan shall be constructed of galvanized steel to inhibit corrosion and be fully insulated. Drain outlet shall be located on pan to allow complete and unobstructed drainage of condensate. Vertical units will have a factory-installed trap inside of cabinet. The standard unit will have solid-state electronic condensate overflow protection. A mechanical float switch will be used with the WSHP Open multiple protocol controller option.

#### F. Filter:

1. Units shall have a factory-installed 1 in. wide filter bracket for filter removal from either side. Units shall have a 1 in. thick throwaway type fiberglass filter.
2. The contractor shall purchase one spare set of filters and replace factory-shipped filters on completion of start-up.

3. Filters shall be standard sizes. If units use non-standard filter sizes then the contractor shall provide 12 spare filters for each unit.
4. Field-installed 2 in. filter brackets and 2 in. fiberglass throwaway filters on all units can be installed by contractor.

#### G. Controls and Safeties:

##### 1. Electrical:

- a. A control box shall be located within the unit compressor compartment and shall contain a 50-va transformer, 24-v activated, 2 or 3 pole compressor contactor, terminal block for thermostat wiring and solid-state controller for complete unit operation. Electro-mechanical operation is not acceptable.
- b. Units shall be nameplated for use with time-delay fuses or HACR circuit breakers. Unit controls shall be 24-v and provide heating or cooling as required by the remote thermostat/sensor.

##### 2. Piping:

- a. Supply and return water connections shall be copper FPT fittings and shall be securely mounted flush to the cabinet corner post allowing for connection to a flexible hose without the use of a back-up wrench.
- b. All water connections and electrical knock-outs must be in the compressor compartment corner post as to not interfere with the serviceability of unit. Contractor shall be responsible for any extra costs involved in the installation of units that do not have this feature.

##### 3. Unit Controls:

- a. Safety controls including a high-pressure switch, a low-pressure sensor, and a low water and low air temperature sensor. Access fittings shall be factory installed on high and low pressure refrigerant lines to facilitate field service.
- b. Activation of any safety device shall prevent compressor operation via a lockout device. The lockout shall be reset at the thermostat or at the contractor-supplied disconnect switch.
- c. Units which may be reset only at the disconnect switch shall not be acceptable.

4. The standard Complete C control electronic control system shall interface with a heat pump (Y,O) wall thermostat (mechanical or electronic). The control system microprocessor board shall be specifically designed to protect against building electrical system noise contamination, EMI, and RFI interference. The control system shall have the following features:

- a. 50-va transformer.

## Guide specifications (cont)

- b. Performance monitor (PM). The PM warns when the heat pump is running inefficiently.
  - c. Anti-short cycle time delay on compressor operation time delay shall be 5 minutes minimum.
  - d. Random start on power up mode.
  - e. Low voltage protection.
  - f. High voltage protection.
  - g. Unit shutdown on high or low refrigerant pressures.
  - h. Unit shutdown on low water temperature.
  - i. Water coil freeze protection (selectable for water or antifreeze).
  - j. Air coil freeze protection (check filter switch).
  - k. Condensate overflow shutdown.
  - l. Option to reset unit at thermostat or disconnect. Fault type shall be retained in memory if reset at thermostat.
  - m. Automatic intelligent reset. Unit shall automatically reset 5 minutes after trip if the fault has cleared. Should a fault reoccur 3 times sequentially then permanent lockout will occur.
  - n. Ability to defeat time delays for servicing.
  - o. Light-emitting diodes (LEDs) to indicate high pressure, low pressure, low voltage, high voltage, air/water freeze protection, condensate overflow and control status.
  - p. The low-pressure switch SHALL NOT be monitored for the first 90 seconds after a compressor start command to prevent nuisance safety trips.
  - q. Remote fault type indication at thermostat.
  - r. Selectable 24-v or pilot duty dry contact alarm output.
  - s. 24-v output to cycle a motorized water valve with compressor contactor.
  - t. Electric heat output to control two stages of electric heat.
  - u. Service test mode for troubleshooting and service.
5. Optional electronic Deluxe D control system shall have all the features of the Complete C control system with the following additional features:
- a. 75-va transformer.
  - b. A removable thermostat connector.
  - c. Random start on return from night setback.
  - d. Intelligent reversing valve operation for extended life and quiet operation.
  - e. Night setback control from low temperature thermostat, with 2-hour override initiated by a momentary signal from the thermostat.
  - f. Dry contact night setback night setback thermostats.
  - g. Ability to work with heat/cool (Y, W) thermostats.
  - h. Ability to work with heat pump thermostats using O or B reversing valve control.
  - i. Single grounded wire to initiate night setback, or emergency shutdown.
  - j. Boilerless system control can switch automatically to electric heat at low loop water temperature.
  - k. Dehumidistat input providing fan control for dehumidification operating.
  - l. Multiple units connected to one sensor providing communication for up to 3 water source heat pumps.
  - m. Selection of boilerless changeover temperature set point.
  - n. Compressor relay staging for dual stage units or in master/slave applications.
6. WSHP Open Multiple Protocol Control:
- Units shall have all the features above (either C or D boards) and the state of the art WSHP Open multiple protocol interface board. All point objects will have the ability to be viewed in the BACview<sup>6</sup> Handheld user interface. This will permit all units to be daisy chain connected by a 2-wire twisted pair shielded cable. The following points must be available at a central or remote computer location:
- a. space temperature
  - b. leaving water temperature
  - c. discharge air temperature
  - d. command of space temperature set point
  - e. cooling status
  - f. heating status
  - g. low temperature sensor alarm
  - h. high pressure switch alarm
  - i. fan on/off position of space thermostat
  - j. unoccupied/occupied command
  - k. cooling demand
  - l. heating demand
  - m. fan "ON/AUTO" command
  - n. fault prevention with auto reset
  - o. itemized fault code viewed with BACview interface
- Additional WSHP Open multiple protocol control features shall include:
- a. two-position OA damper
  - b. modulating OA damper with DCV
  - c. auxiliary modulating hot water/steam heating
  - d. two-position hot water/steam heating





- e. single stage electric auxiliary heat
  - f. auto fan speed control (heating/cooling)
  - g. power fail restart delay
  - h. dehumidification
  - i. modulating water economizer control
  - j. two-position water economizer control
7. PremierLink™ controller will function with CCN and ComfortVIEW™ software. It shall also be compatible with ComfortLink™ controllers. It shall be ASHRAE 62-99 compliant and Internet ready. It shall accept a CO<sub>2</sub> sensor in the conditioned space and be demand controlled ventilation (DCV) ready. The communication rate must be 38.4K or faster. It shall include an integrated economizer controller.

#### H. Special Features:

1. Cupronickel coaxial water-to-refrigerant heat exchangers can be provided.
2. E-coated airside coil provides protection from corrosion in coastal areas, marine applications or other areas in which corrosion may be an issue.
3. High-static blower provides increased airflow at various static pressure conditions (available on sizes 015-060).
4. Aquazone™ thermostat controls are available as follows:
  - a. Programmable multi-stage thermostat offers 7-day clock, holiday scheduling, large backlit display, and remote sensor capability.
  - b. Programmable 7-day light-activated thermostat offers occupied comfort settings with lights on, and unoccupied energy savings with lights off.
  - c. Programmable 7-day flush-mount thermostat offers locking coverplate with tamper proof screws, flush to wall mount, dual point with adjustable deadband, O or B terminal, and optional remote sensor.
  - d. Programmable 5-day thermostat offers 2-stage heat, 2-stage cool, auto changeover, 5-minute built-in compressor protection, and included locking cover.
  - e. Non-programmable thermostat offers 2 heat stages, 2 cool stages, auto changeover, 5-minute built-in compressor protection, and included locking cover.
5. A loop controller with six stages (2 stages for heating and 4 stages for heat rejection) can be provided.
6. A filter rack (2 in.) to enhance the filtration system of the water source heat pump is available. NOTE: Filter rack does not include filters.
7. Fire-rated hose kits with a fixed MPT on one end and a swivel with an adapter on the other

- end are available. Hose kits can be either stainless steel or galvanized.
8. Ball valves (brass body) for shut off and balancing water flow are available with memory, memory stop, and pressure temperature ports.
  9. Y strainers (bronze body) are “Y” type configuration with a brass cap and stainless steel strainer screen. Maximum operating pressure rating of strainer is 450 psi.
  10. Solenoid valves (brass body) provide slow operation for quiet system application.
  11. Hose kit assemblies include a ported ball valve with pressure temperature (P/T) plug ports and flexible stainless steel hose with swivel and nipple. Return hose includes a ball valve, preset measure flow (gpm) with two P/T ports, and flexible stainless steel hose with a swivel and nipple.
  12. Multiple-protocol WSHP Open controller remote sensors for Aquazone flush-mount thermostats and DDC control options. Only Carrier sensors can be used with the WSHP Open controller. Sensors are available as follows:
    - a. SPT Standard offers space temperature sensor with communication port.
    - b. SPT Plus offers space temperature sensor with set point adjust, local override with indicating light and communication port.
    - c. SPT Pro offers space temperature sensor with LCD display, set point adjust, local override, alarm icon, outside air, and unit status with heating and cooling set points.
    - d. SPT Pro+ offers space temperature sensor with LCD display, set point adjust, local override, alarm icon, outside air, unit status with heating and cooling set points, and fan speed control.
  13. PremierLink™ accessories for providing a fully integrated DDC system are available including supply air temperature sensors, communicating room sensors, CO<sub>2</sub> sensors, and linkage thermostats.
  14. Aquazone system control panel as specified in the 50RLP Product Data (525-00040) is available.
  15. Sound attenuation (mute) package shall consist of high technology sound attenuating materials strategically applied to the cabinet, in addition to the standard system, to further dampen sound.
  16. Extended range for units operating with entering water temperatures below dew point. Extended entering water temperatures range from 20 to 120 F.

## Guide specifications (cont)



17. LONMark compliant controller shall contain the factory-loaded Aquazone water source heat pump application for an interoperable control solution.
18. Full filter frame shall be available in place of the standard 1 in. return air filter. The frame shall include a locking door to facilitate filter changes and cleaning without disrupting duct connections. Frames shall be available in 1 and 2 in. sizes.
19. LON wall sensors are available in 3 models: sensor only, sensor with status override indicator, and sensor with set point, status adjustment override, and digital LCD display.



