



Product Data

OMNIZONE™ 50XCA06-24 Air-Cooled

Indoor Self-Contained Systems with PURON® Refrigerant (R-410A)

5 to 20 Nominal Tons



OMNIZONE™

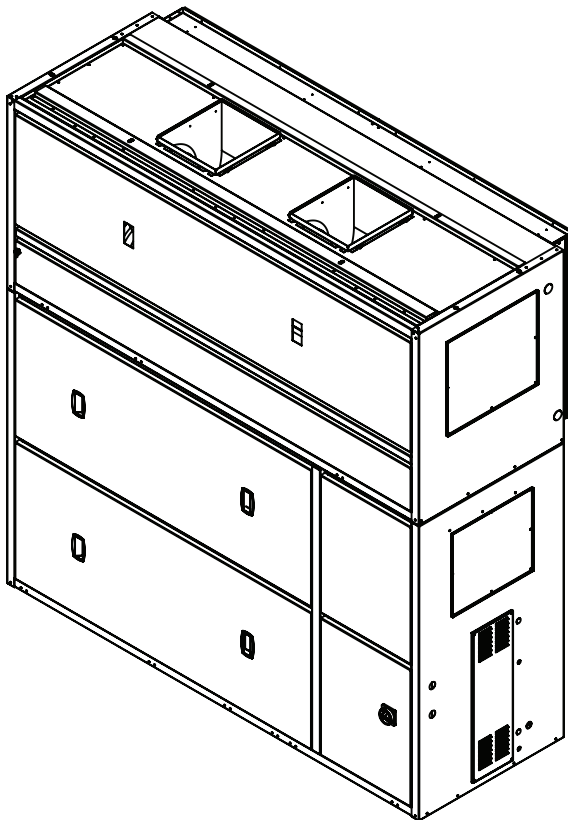

The 50XCA single-package cooling units with integral air-cooled condensers offer:

- Compact, durable, and attractive cabinet fits any working environment
- Available in ducted or free return with rear return connections with vertical supply air discharge
- Provides high-efficiency cooling for commercial and industrial projects
- Rear condenser inlet and discharge and belt drive condenser fan permit condenser air connections to be ducted through window or wall louver
- Uses Puron® refrigerant (R-410A)

Features/Benefits

The Omnizone 50XCA units provide a practical and economical approach to comfort conditioning requirements for offices, factories, and other applications in existing buildings when indoor air-cooled condensers are required.

Design flexibility

The 50XCA indoor packaged units are designed to provide the flexibility required in replacement, renovation, and new construction. Units are available in 6 sizes from 5 tons to 20 tons which meet the needs for cooling restaurants, retail stores, warehouses, offices, and building additions.



Features/Benefits (cont)



The compact footprint and service from the front of the units save valuable floor space in equipment rooms. Belt drive condensers provide adequate static to overcome ducting and louver static losses. This allows units to be positioned against an existing window or wall louver, or ducted to the outside, as required. These units can be installed in the equipment room or the conditioned space and used for either ducted or free return applications. Unit supply air discharge is vertical.

Easy installation and maintenance

The units are completely pre-piped and wired at the factory to ensure time and money saving installation and service. Exterior access panels are easily removed to provide speedy inspection, and service work may be done from the front of the unit. Precision engineered parts translate to a quality built, reliable design that will operate efficiently, minimize service calls, and provide years of reliable operation.

Designed for customer satisfaction

Where space and styling are important considerations, 50XCA units are designed to exceed expectations. The high quality baked enamel finish will fit any environment attractively. These packaged systems provide the user with economy and product satisfaction in cooling, dehumidification, filtering, and air circulation.

Efficient design to increase savings

In order to provide an energy efficient HVAC solution, all 50XCA units have been designed to exceed the ASHRAE 90.1 (2010) guidelines.

Special features for outstanding performance

- High-efficiency scroll compressors deliver quiet, reliable cooling capacity. Compressor motor protection is assured by quick-acting, internal sensing elements that prevent trouble before it starts.

- Space-saver slab type evaporator and condenser coils use advanced heat transfer technology and provide peak heat transfer efficiency with large coil face area. Fins are mechanically bonded to nonferrous, seamless tubing for efficient leak-free operation.
- Quiet fan performance moves large volumes of indoor air. Compact housing and specially designed discharge air section provide superior air-handling capacity. Vertical supply air discharge is standard. Horizontal supply air option available on sizes 10 to 20 tons.
- Convenient front access electrical control center contains all factory pre-wired control devices.
- A stainless steel, sloped, condensate pan is standard. As a result of this new design, the coil is easily accessed for cleaning.
- The cabinets are constructed of galvanized steel, bonderized, and coated on all external surfaces with a baked enamel finish. The paint finish is nonchalking and is capable of withstanding ASTM (American Society for Testing and Materials) Standard No. B117 500-hour salt spray test.
- Choose between a full line of room-mounted thermostats.
- Full compressor protection is assured by several devices, including current-sensing lockout relay(s), anti-short cycle control, and high and low-pressurestats. These devices lock out the compressor(s) under abnormal operating conditions to prevent compressor damage and ensure long life.
- The 50XCA units are covered by a standard limited 5-year warranty on the compressor and a standard limited one-year warranty on all other parts.
- Easy to understand and operate controls provide a virtually mistake-proof control operation.
- All motors are protected against single-phasing conditions.
- Units are built in an ISO 9001:2000 (International Standards Organization) certified manufacturing facility, and are fully run-tested.

Environmentally sound

Carrier's Puron® refrigerant (R-410A) enables you to make an environmentally responsible decision. Puron refrigerant (R-410A) is an HFC refrigerant that does not contain chlorine that is damaging to the stratospheric ozone layer. Puron refrigerant (R-410A) is unaffected by the Montreal Protocol. Puron refrigerant (R-410A) is a safe, efficient and environmentally sound refrigerant for the future.

Table of contents

	Page
Features/Benefits	1,2
Model Number Nomenclature	3
AHRI Capacity Ratings	3
Physical Data	4
Options and Accessories	5
Dimensions	6-12
Selection Procedure	12
Performance Data	13-30
Electrical Data	31,32
Typical Wiring Schematics	33-38
Controls	39
Typical Piping and Wiring	40
Application Data	41,42
Guide Specifications	43,44

Model number nomenclature



50XC A 24 A A - J 5 A A H 0 AA

50XC – OMNIZONE™ Indoor Packaged Unit

Condenser Option

A – Air-Cooled

Unit Size – Nominal Tons

06 – 5 14 – 12
 08 – 7 1/2 16 – 15
 12 – 10 24 – 20

Return Air/Discharge Air Options

A – Rear Return, Vertical Discharge, Single Unit, Ducted
 E* – Rear Return, Front Discharge, Single Unit, Ducted

Heating Coil Options

A – No Factory Installed Heating Coil

Evaporator Fan Speed

Set by selection program

Evaporator Motor Hp Options

B – 1/2 Hp Motor F – 2 Hp Motor
 C – 3/4 Hp Motor G – 3 Hp Motor
 D – 1 Hp Motor H – 5 Hp Motor
 E – 1 1/2 Hp Motor J – 7 1/2 Hp Motor

Voltage Options

1 – 575-3-60
 5 – 208/230-3-60
 6 – 460-3-60

Factory-Installed Options Code

See codes in unit price pages

Design Revision Level

0 – Original Release

Condenser Motor Hp Options

D – 1 Hp Motor
 E – 1 1/2 Hp Motor
 F – 2 Hp Motor
 G – 3 Hp Motor
 H – 5 Hp Motor
 J – 7 1/2 Hp Motor

Condenser Coil Options

A – No Condenser Filter, No Low Ambient Option, Low ESP
 B – No Condenser Filter, No Low Ambient Option, Medium ESP
 C – No Condenser Filter, No Low Ambient Option, High ESP
 D – No Condenser Filter, No Low Ambient Option, Highest ESP†
 F – No Condenser Filter, Low Ambient Option, Low ESP
 G – No Condenser Filter, Low Ambient Option, Medium ESP
 H – No Condenser Filter, Low Ambient Option, High ESP
 J – No Condenser Filter, Low Ambient Option, Highest ESP†

Control Options

A – Standard Controls

* Front discharge not available on size 06 or 08.

† Highest ESP not available for size 14-24.

AHRI* capacity ratings

UNIT 50XCA	NOMINAL TONS	EVAPORATOR CFM	CONDENSER CFM	NET COOLING (Btuh)	TOTAL kW	EER	IEER
06	5	1,875	2,800	65,000	5.8	11.2	11.4
08	7 ¹ / ₂	2,625	3,500	80,000	7.1	11.2	11.4
12	10	3,500	5,500	119,000	10.6	11.2	11.4
14	12	4,200	8,000	140,000	12.7	11.0	11.2
16	15	5,250	8,000	162,000	14.7	11.0	11.2
24	20	7,000	11,400	240,000	24.0	10.0	10.1

LEGEND

EER — Energy Efficiency Ratio
 IEER — Integrated Energy Efficiency Ratio

*AHRI — Air Conditioning, Heating, and Refrigeration Institute.

NOTE: Unit is tested in accordance with AHRI standard 340/360.



Physical data



UNIT 50XCA	06	08	12	14	16	24
NOMINAL CAPACITY (tons)	5	7.5	10	12	15	20
UNIT OPERATING WEIGHT (lb)	891	1144	1269	1298	1575	2000
COMPRESSOR	Scroll					
Compressor Model	ZP57	ZP67	ZP51	ZP57	ZP72	ZP103
Qty	1	1	2	2	2	2
Steps of Control	1	1	2	2	2	2
Operating Charge R-410A (lb)	17.4	21.4	15.5 / 14.6	22.1 / 20.8	26.1 / 19.1	26.6 / 19.5
EVAPORATOR FAN	Adjustable, Belt-Drive, Centrifugal					
Nominal Cfm	1750	2625	3500	4375	5250	7500
Cfm Range	1500 to 2500	2250 to 3750	3000 to 5000	3600 to 6000	4500 to 7500	6000 to 10000
Available Static (in. wg)	0 - 1.6	0 - 1.6	0 - 1.6	0 - 1.6	0 - 1.6	0 - 1.6
Evaporator Fan Size	110-10R	110-10R	120-9R	120-9R	120-9R	120-11R
Number of Evaporator Fans	1	2	2	2	3	3
Standard Speed Range (Rpm)	576 - 782	712 - 949	656 - 875	712 - 949	689 - 918	762 - 931
Max. Allowable Rpm	1600	1700	1700	1700	1700	1700
Vertical Belt (Type)	A48	BX41	BX48	BX47	BX47	BX60
Fan Pulley (Type)	AK89	BK65	BK70	BK65	BK67	BK95
Motor Pulley (Type)	1VL44	1VP34	1VP34	1VP34	1VP34	1VP50
Std HP	.5	1	1	1.5	1.5	3
HP Range	.5 - 2	1 - 2	1 - 3	1.5 - 5	1.5 - 5	3 - 7.5
Fan Shaft Size (in.)	0.75	1	1	1	1.1875	1.1875
Motor Shaft Size (in.)	0.625	0.875	0.875	0.875	0.875	1.125
Center Distance (in.) - Vertical	15.3	15.3	18.1	18.1	18.1	21.3
Center Distance (in.) - Horizontal	N/A	N/A	15.5	13.0	15.7	18.1
EVAPORATOR COIL	³ / ₈ -in. OD, Enhanced Copper Tube, Aluminum Fins					
Quantity Rows ... Fin/in.	4...12	4...12	5...12	5...12	5...12	5...12
Fin Block Size (H x L) (in.)	28 x 34	28 x 46	32 x 60	32 x 60	32 x 80	36 x 80
Face Area (sq ft)	6.6	8.9	13.3	13.3	17.8	20.0
RETURN AIR FILTERS						
Std 1 in., throwaway	(2) 25 x 25	(2) 25 x 25	(8) 16 x 16	(8) 16 x 16 (2) 16 x 20	(8) 16 x 16 (2) 16 x 20	(4) 18 x 18 (4) 18 x 24
CONDENSER FAN	Adjustable, Belt-Drive, Centrifugal					
Nominal Cfm	2800	3500	5500	8000	8000	11400
Cfm Range	2100 - 3500	2625 - 4300	4125 - 6875	6000 - 9500	6000 - 9500	8550 - 12700
Available Static	0 - 1.0	0 - 1.0	0 - 1.0	0 - 1.0	0 - 1.0	0 - 1.0
Condenser Fan Size	110-10R	110-10R	150-12R	150-15R	150-15R	150-11R
Number of Condenser Fans	2	2	2	2	2	3
Standard Speed Range (Rpm)	656 - 875	712 - 949	712 - 949	764 - 1011	764 - 1011	820 - 1041
Max. Allowable Rpm	1700	1700	1700	1600	1600	1700
Belt (Type)	BX66	BX65	BX75	BX77	BX82	BX87
Fan Pulley (Type)	BK70	BK65	BK90	BK100	BK130	BK85
Motor Pulley (Type)	1VP34	1VP34	1VP34	1VP34	1VP44	1VP50
Std HP	1	1.5	2	2	3	5
HP Range	1 - 1.5	1.5 - 2	2 - 3	2 - 3	3 - 5	5 - 7.5
Fan Shaft Size (in.)	1	1	1	1.1875	1.1875	1.4375
Motor Shaft Size (in.)	0.875	0.875	0.875	0.875	1.125	1.125
Center Distance (in.)	27.1	27.1	29.8	29.8	29.8	35.1
CONDENSER COIL	³ / ₈ -in. OD, Enhanced Copper Tube, Aluminum Fins					
Quantity Rows ... Fin/in.	6...16W	6...16W	6...16W	6...16W	6...16W	6...16W
Fin Block Size (H x L) (in.)	30 x 46	30 x 46	34 x 60	34 x 80	34 x 80	40 x 80
Face Area (sq ft)	9.58	9.58	14.17	18.89	18.89	22.22
HIGH PRESSURE SWITCH	Opens at 595 ± 10 psig; Closes at 443 ± 15 psig					
LOW PRESSURE SWITCH	Opens at 53 ± 5 psig; Closes at 80 ± 7 psig					
CONDENSATE DRAIN LINE (in.)	1 at ³ / ₄ MPT (Male Pipe Thread)					

Options and accessories



ITEM	FACTORY-INSTALLED OPTION	FIELD-INSTALLED ACCESSORY
Hot Water Coil		X
Low Ambient Operation	X	
Supply Air Plenum		X
Winter Start Operation	X	

Factory-installed options

Low ambient option allows a refrigerant pressure controlled VFD (variable frequency drive) to adjust condenser fan speed to control head pressure. This fan speed control permits unit to operate in cooling even in winter, when outdoor air temperature is down to 0° F.

Winter start option provides a bypass of low pressure switch on start up for initial 90 seconds.

Field-installed accessories

Supply air plenum provides adjustable horizontal and vertical louvers for controlled free blow into conditioned space. The plenum mounts easily on top of base unit and matches unit styling.

Hot water coil provides a 2 row coil encased in a 5 in. deep metal casing.

Dimensions — 50XCA06,08



REAR RETURN, VERTICAL DISCHARGE

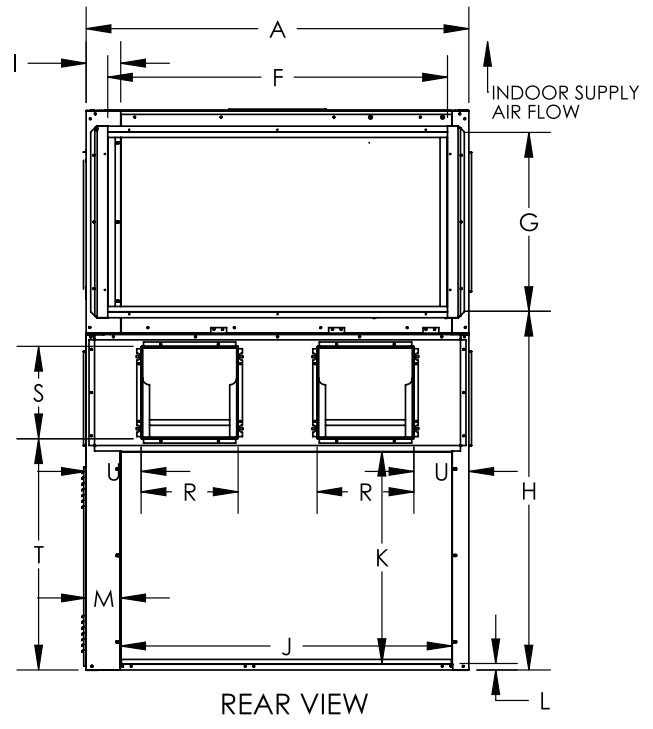
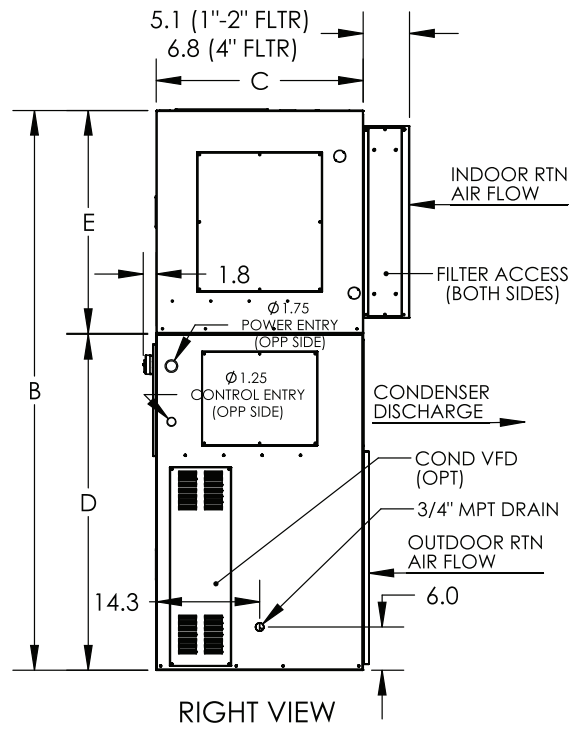
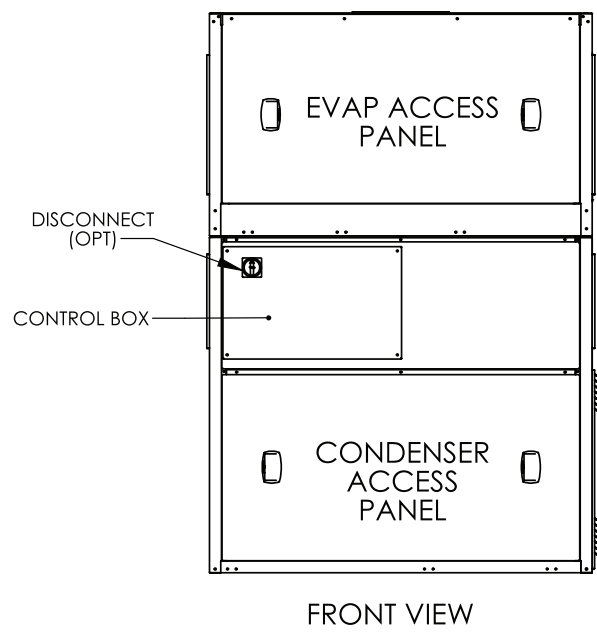
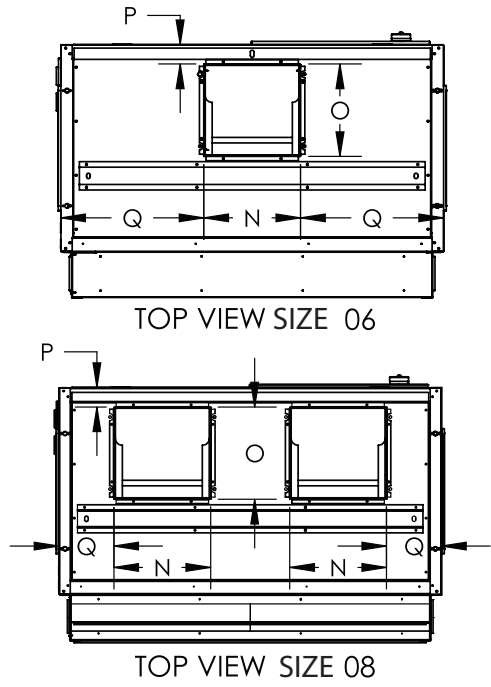

UNIT 50XCA	WIDTH	HEIGHT	DEPTH	COND SECTION	EVAP SECTION	EVAP RETURN DUCT				COND RETURN DUCT			EVAP SUPPLY DUCT (Blower Opening)				COND DISCHARGE DUCT (Blower Opening)				
	A	B	C	D	E	F	G	H	I	J	K	L	M	N	O	P	Q	R	S	T	U
06	53.1	77.1	29.0	46.6	31.0	47.2	24.8	49.8	4.8	46	29.4	0.9	4.8	13.4	12.8	2.7	19.8	13.4	12.8	32.1	7.6
08	53.1	77.1	29.0	46.6	31.0	47.2	24.8	49.8	4.8	46	29.4	0.9	4.8	13.4	12.8	2.7	7.6	13.4	12.8	32.1	7.6

NOTE: Dimensions are in inches.

Dimensions — 50XCA12,14



REAR RETURN, VERTICAL DISCHARGE

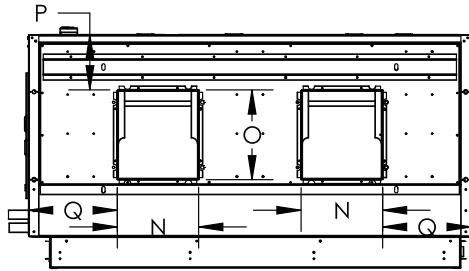

TOP VIEW

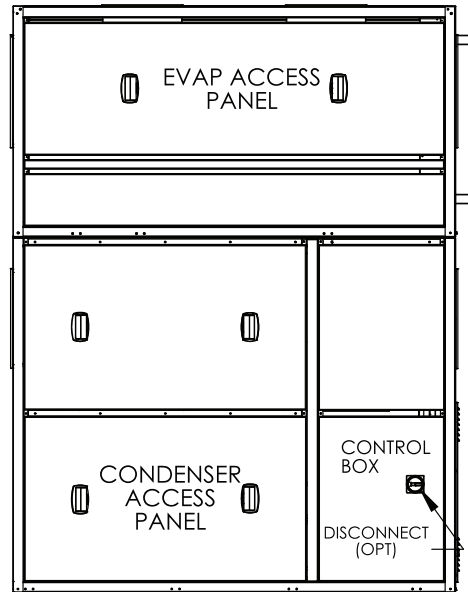

FRONT VIEW

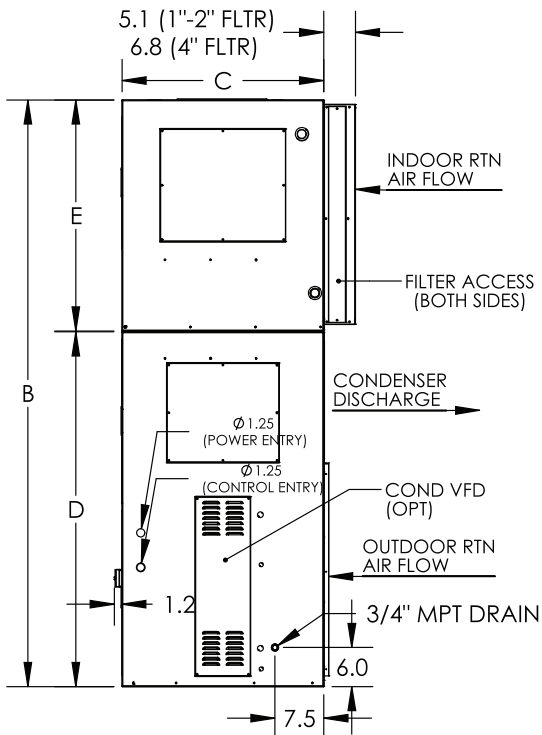

RIGHT VIEW

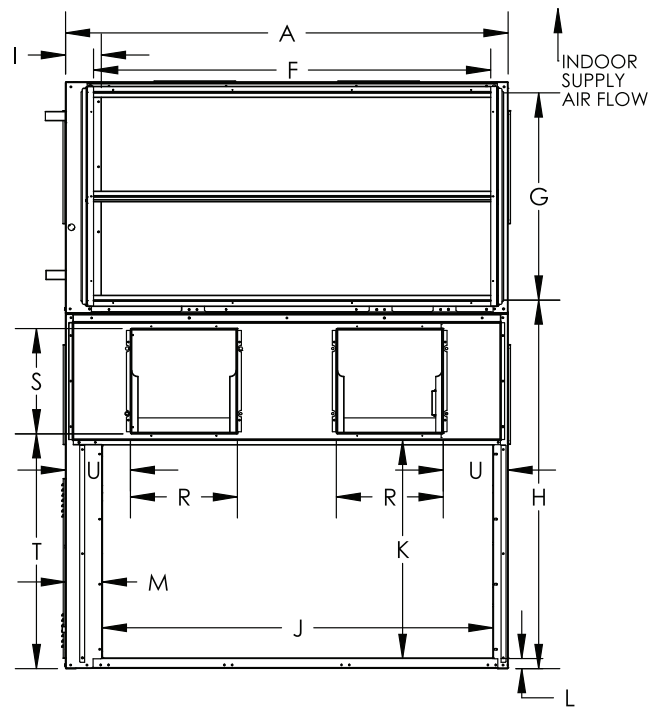

REAR VIEW

UNIT 50XCA	WIDTH	HEIGHT	DEPTH	COND SECTION	EVAP SECTION	EVAP RETURN DUCT				COND RETURN DUCT				EVAP SUPPLY DUCT (Blower Opening)				COND DISCHARGE DUCT (Blower Opening)			
	A	B	C	D	E	F	G	H	I	J	K	L	M	N	O	P	Q	R	S	T	U
12	68.0	90.1	31.2	54.5	35.5	61.1	31.8	56.7	5.5	60	32.8	1.5	5.7	12.5	13.8	8.5	13.6	16.4	16.2	36.5	11.5
14	88.0	90.1	31.2	54.5	35.5	81.0	31.8	56.7	2.5	80	32.8	1.5	5.7	12.5	13.8	8.9	23.6	18.9	16.2	36.6	17.2

NOTE: Dimensions are in inches.

Dimensions — 50XCA12,14 (cont)



REAR RETURN, FRONT DISCHARGE

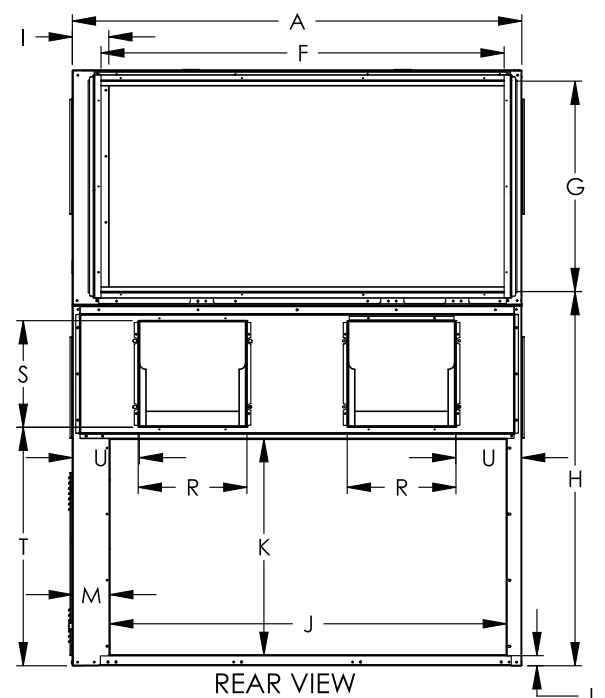
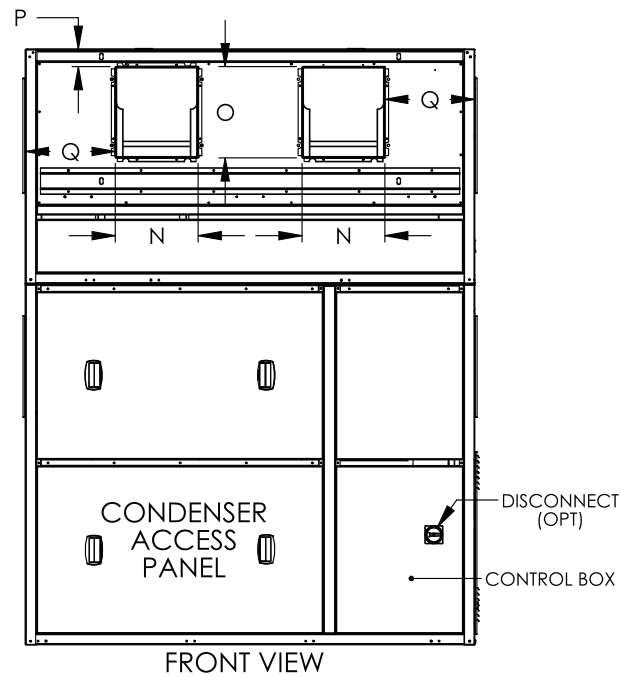
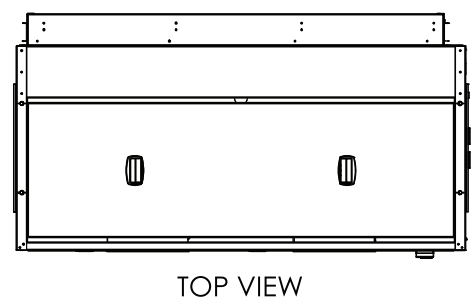
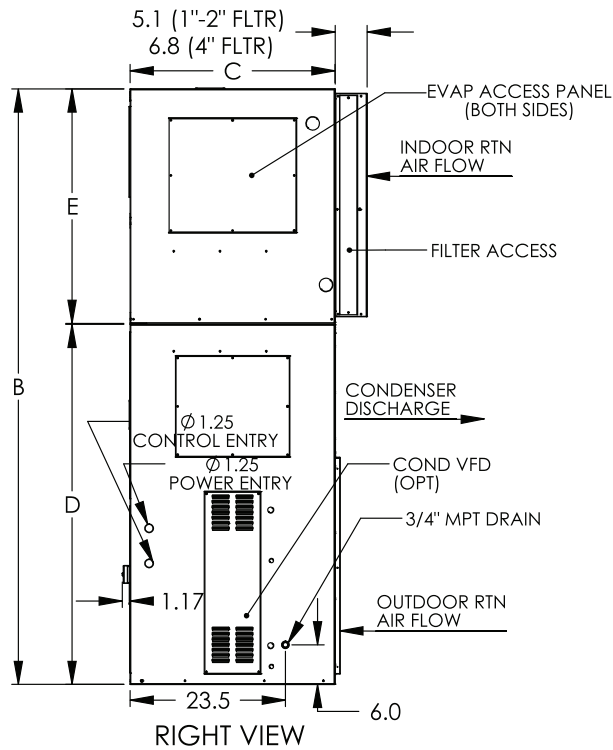

UNIT 50XCA	WIDTH	HEIGHT	DEPTH	COND SECTION		EVAP RETURN DUCT				COND RETURN DUCT				EVAP SUPPLY DUCT (Blower Opening)				COND DISCHARGE DUCT (Blower Opening)			
	A	B	C	D	E	F	G	H	I	J	K	L	M	N	O	P	Q	R	S	T	U
12	68.0	90.1	31.2	54.5	35.5	61.1	31.8	56.7	5.5	60	32.8	1.5	5.7	12.5	13.8	2.7	13.6	16.4	16.2	36.5	11.5
14	88.0	90.1	31.2	54.5	35.5	81.0	31.8	56.7	2.5	80	32.8	1.5	5.7	12.5	13.8	2.7	23.6	18.9	16.2	36.6	17.2

NOTE: Dimensions are in inches.

Dimensions — 50XCA16,24



REAR RETURN, VERTICAL DISCHARGE

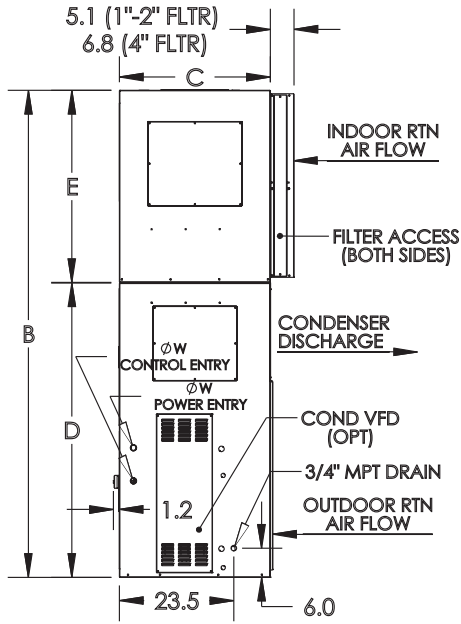

RIGHT VIEW

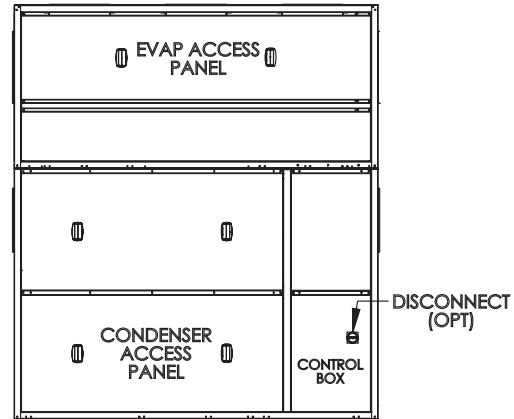

FRONT VIEW

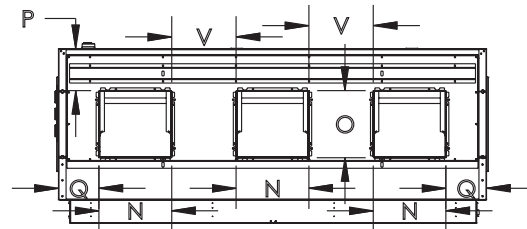

TOP VIEW

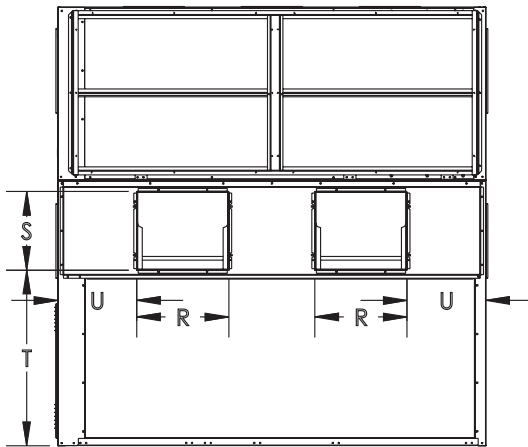

REAR VIEW SIZE 16

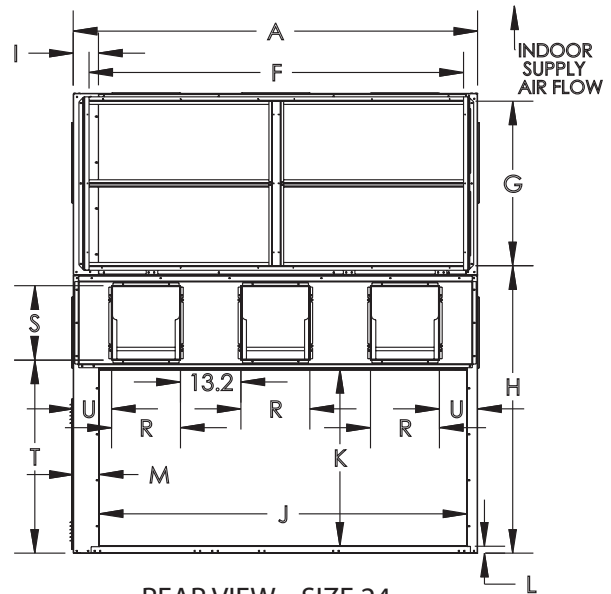

REAR VIEW SIZE 24

UNIT 50XCA	WIDTH	HEIGHT	DEPTH	COND SECTION		EVAP SECT			EVAPORATOR RETURN DUCT			CONDENSER RETURN DUCT				EVAP SUPPLY DUCT (Blower Opening)				COND DISCHARGE DUCT (Blower Opening)				DIA*
	A	B	C	D	E	F	G	H	I	J	K	L	M	N	O	P	Q	V	R	S	T	U	W	
16	88.0	90.1	31.2	54.5	35.5	81.0	31.8	56.7	5.5	80	32.8	1.5	5.7	12.5	13.8	8.5	13.5	11.7	18.9	16.2	36.5	16.2	1.25	
24	88.0	100.1	31.2	60.5	39.5	81.5	35.8	62.6	5.5	80	38.5	1.5	5.7	14.9	13.8	8.6	8.3	13.2	15.0	16.2	42.0	8.3	2.00	

* Diameter of power and control entries.
NOTE: Dimensions are in inches.

Dimensions — 50XCA16,24 (cont)



REAR RETURN, FRONT DISCHARGE

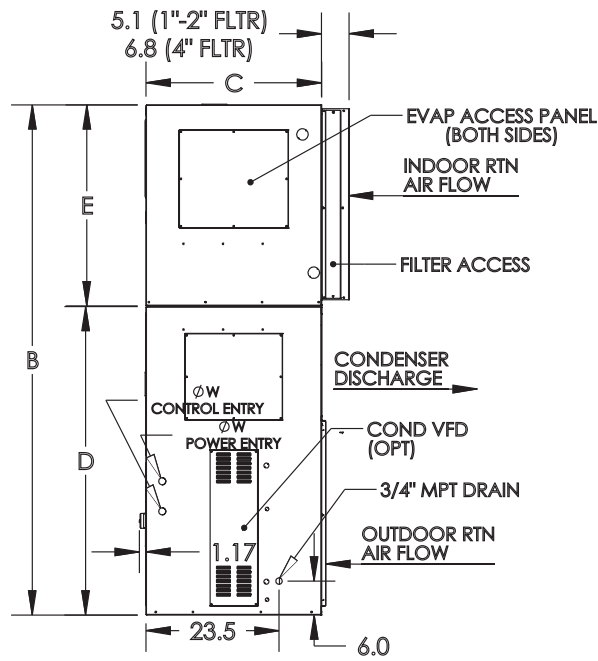

RIGHT VIEW

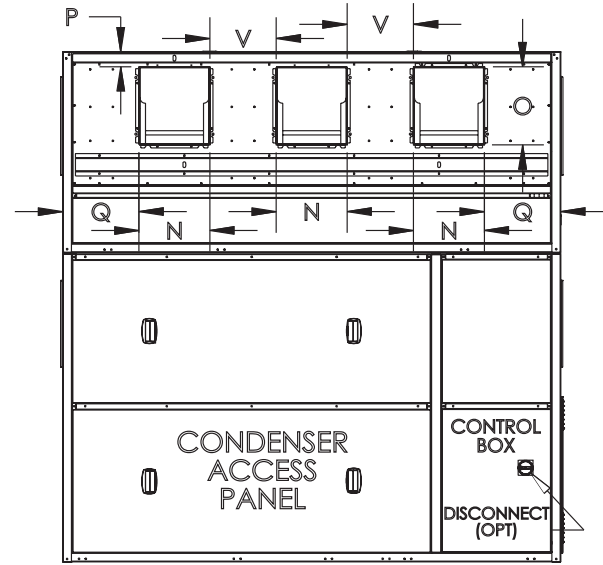

FRONT VIEW

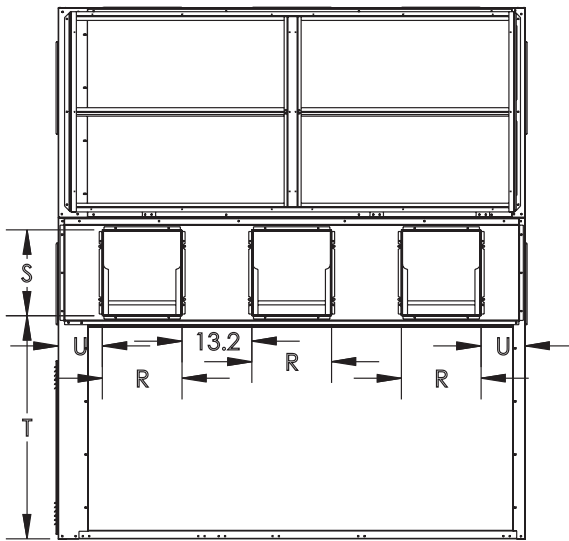

REAR VIEW SIZE 24

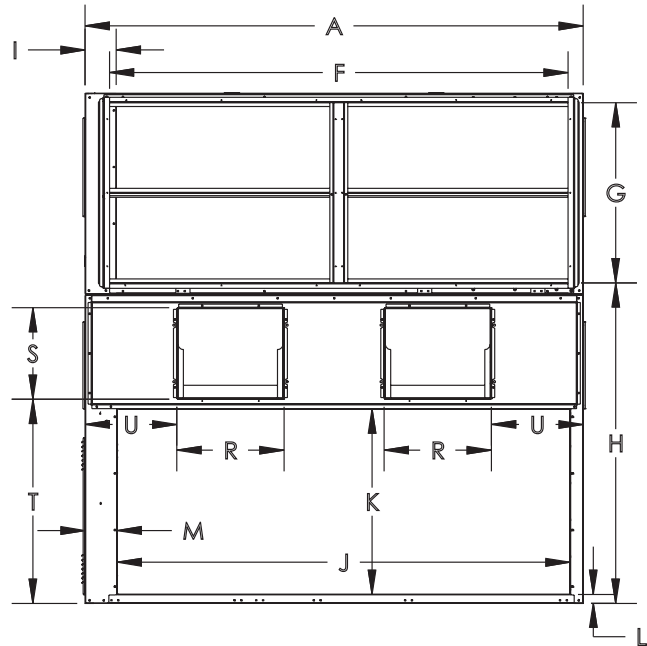

REAR VIEW SIZE 16

UNIT 50XCA	WIDTH	HEIGHT	DEPTH	COND SECTION	EVAP SECT	EVAPORATOR RETURN DUCT				CONDENSER RETURN DUCT				EVAP SUPPLY DUCT (Blower Opening)				COND DISCHARGE DUCT (Blower Opening)					DIA*
	A	B	C	D	E	F	G	H	I	J	K	L	M	N	O	P	Q	V	R	S	T	U	
16	88.0	90.1	31.2	54.5	35.5	81.0	31.8	56.7	5.5	80	32.8	1.5	5.7	12.5	13.8	8.5	13.5	11.7	18.9	16.2	36.5	16.2	1.25
24	88.0	100.1	31.2	60.5	39.5	81.5	35.8	62.6	5.5	80	38.5	1.5	5.7	14.9	13.8	8.6	8.3	13.2	15.0	16.2	42.0	8.3	2.00

* Diameter of power and control entries.
NOTE: Dimensions are in inches.

50XC PLENUM UNIT

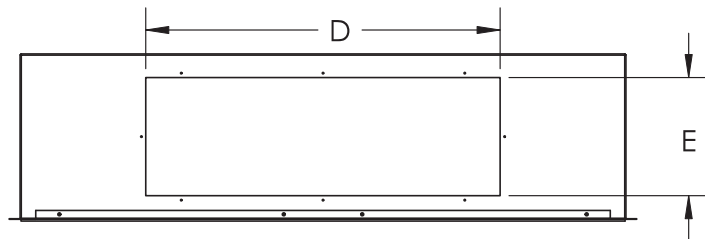
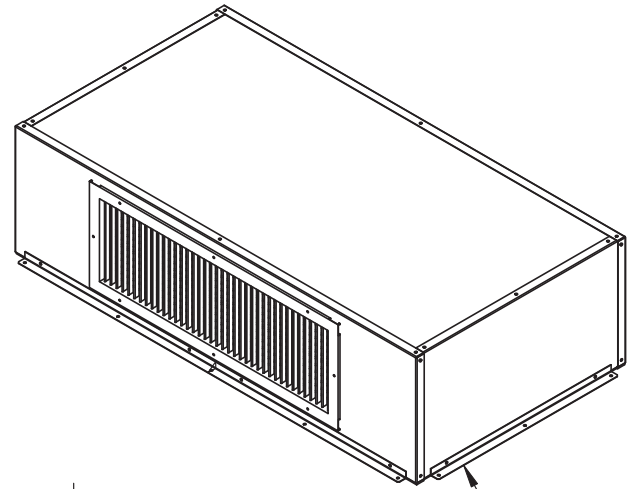

**FRONT VIEW
LESS GRILLE**

MOUNTING ANGLES

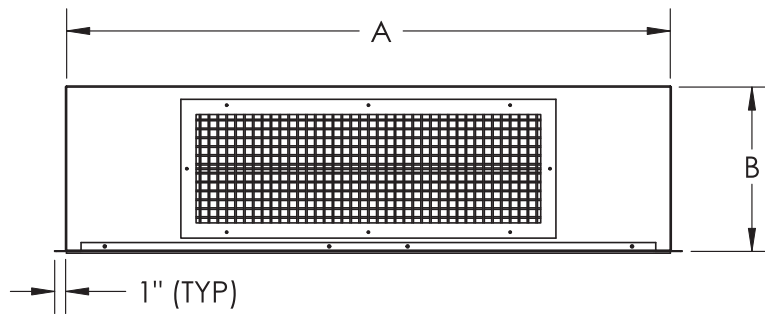

FRONT VIEW

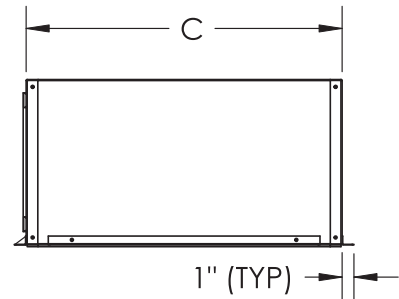

RIGHT VIEW

MODEL	UNIT SIZE	A	B	C	D	E	WGT (lb)
50XCA900-200A00	06	51.3	14.0	26.8	30.0	10.0	65
50XCA900-201A00	08	51.3	14.0	26.8	45.0	10.0	65
50XCA900-202A00	12	66.0	14.0	28.9	60.0	10.0	80
50XCA900-203A00	14	86.0	19.0	28.9	48.0	15.0	115
50XCA900-204A00	16	86.0	19.0	28.9	60.0	15.0	115
50XCA900-205A00	24	86.0	19.0	28.9	80.0	15.0	115

Dimensions (cont)

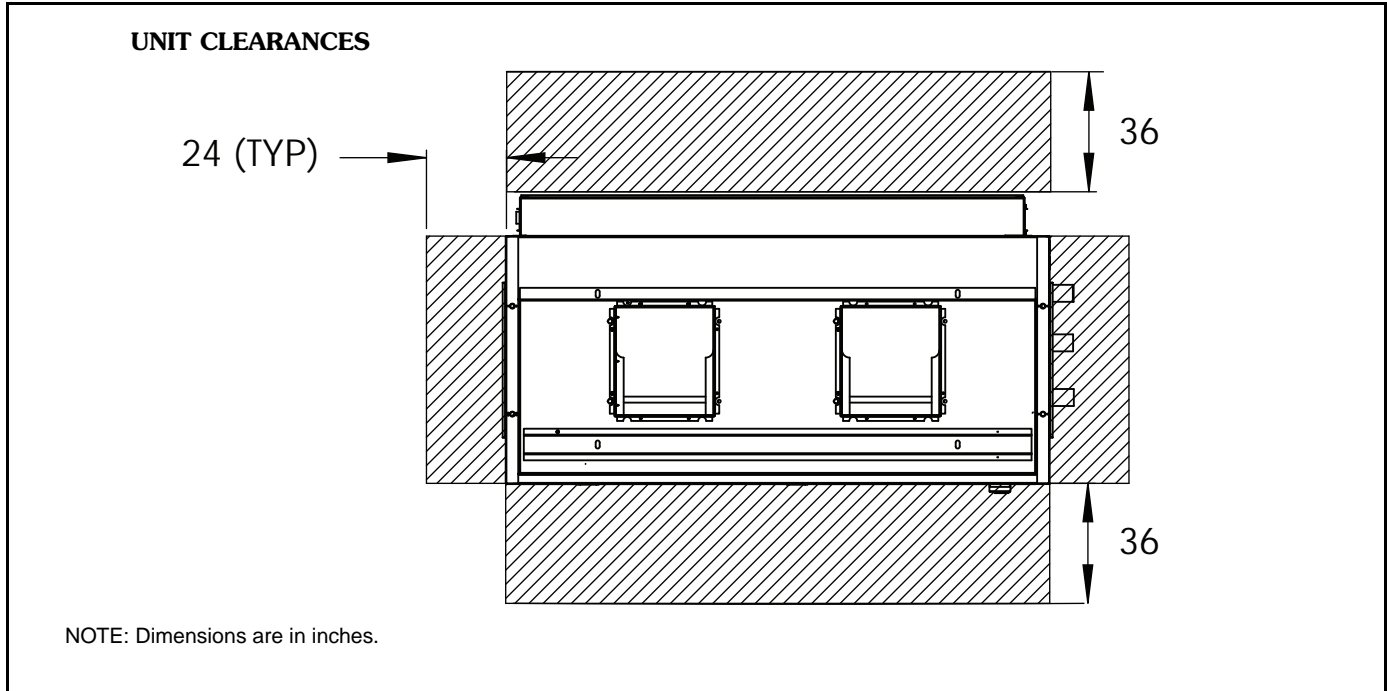

Selection procedure (50XCA08 unit example)

I Determine design conditions.

Given:

Cooling Requirements

Total Cooling Capacity (TC)	82,000 Btuh
Sensible Cooling Capacity (SHC)	65,000 Btuh
Evaporator Air Quantity	3,000 Cfm
Condenser Air Quantity	3,500 Cfm
Summer Entering-Air Conditions:	
Entering dry bulb (edb)	80 F
Entering wet bulb (ewb)	67 F
Entering Condenser Air Temp (EAT)	95 F
Unit Voltage	460 V

Fan Requirements

External Static Pressure Required	0.75
ESP (in. wg)	0.75

II Select unit based on cooling requirements.

Enter Gross Cooling Capacities table for 50XCA08 unit at 3000 cfm and required wet bulb of 67 F and read down to the section displaying capacities with 95 F entering-air temperature. The 50XCA08 provides a total capacity closest to design requirements.

For example:

Unit selection — 50XCA08

Selected at 3000 cfm of 80 F edb, 67 F ewb entering air.

TC = 83,800 Btuh

SHC = 66,500 Btuh

Compressor — Power Input = 5.85 kW

Leaving Air db
= 59.9 F

Leaving Air wb at 67 F wb
= 58.3 F

III Fan requirements.

External static pressure (ESP) required 0.75 in. wg

Enter Evaporator Fan Performance table for cfm, and static pressure required to obtain the following data:

For 3000 cfm and 0.75 ESP, by interpolation the fan operates at 967 rpm and requires 0.97 brake horsepower.

Since standard motor horsepower is 1.0, it will produce the necessary cfm and ESP for this job.

Performance data



GROSS COOLING CAPACITIES

50XA06 (5 TONS)

Entering Condenser Air		BF	AIR ENTERING EVAPORATOR — 80 F Edb (F) - CFM											
			2500				2000				1500			
ECT (F)	CFM		Air Entering Evaporator — Ewb (F)											
		57	62	67	75	57	62	67	75	57	62	67	75	
		0.20	0.10	0.10	0.03	0..34	0.15	0.14	0.10	0.44	0.22	0.18	0.15	
55	2100	TC	73.4	74.8	80.4	90.4	68.8	71.9	77.8	87.8	62.9	67.9	73.7	83.7
		SHC	73.4	70.2	58.6	38.9	68.8	63.2	53.4	36.9	62.1	55.2	47.5	34.5
		LDB	53.08	54.40	58.75	65.92	48.48	51.18	55.83	63.36	42.07	46.49	51.34	59.30
		LWB	45.41	51.41	56.79	65.43	43.16	48.97	54.36	63.10	39.61	45.04	50.43	59.29
	2800	TC	74.0	75.7	81.5	92.2	69.3	72.7	78.8	89.4	63.3	68.5	74.5	85.0
		SHC	74.0	70.7	59.0	39.5	69.3	63.6	53.7	37.4	62.4	55.4	47.8	35.0
		LDB	52.85	54.22	58.60	65.71	48.23	51.03	55.66	63.11	41.87	46.35	51.15	59.01
		LWB	45.30	51.28	56.63	65.22	43.03	48.84	54.18	62.86	39.46	44.88	50.23	59.00
	3500	TC	74.5	76.1	82.2	93.1	69.6	73.0	79.4	90.2	63.5	68.8	75.0	85.6
		SHC	74.5	70.9	59.3	39.9	69.6	63.8	54.0	37.7	62.5	55.6	48.0	35.2
		LDB	52.70	54.13	58.49	65.59	48.09	50.95	55.54	62.97	41.79	46.23	51.01	58.88
		LWB	45.22	51.21	56.54	65.11	42.96	48.76	54.08	62.73	39.39	44.77	50.11	58.87
75	2100	TC	68.7	69.3	74.4	83.5	64.6	66.7	72.1	81.3	59.0	63.2	68.6	77.8
		SHC	68.7	67.3	56.1	36.5	64.6	60.6	50.9	34.5	59.0	52.8	45.1	32.2
		LDB	54.80	55.46	59.67	66.79	50.37	52.37	56.96	64.42	43.96	47.94	52.76	60.63
		LWB	46.22	52.26	57.64	66.23	44.09	50.05	55.40	64.09	40.86	46.40	51.77	60.58
	2800	TC	69.5	70.3	75.5	85.2	65.2	67.6	73.1	82.8	59.5	63.8	69.5	79.1
		SHC	69.5	67.8	56.5	37.1	65.2	61.1	51.3	35.0	59.5	53.1	45.5	32.7
		LDB	54.52	55.26	59.51	66.59	50.10	52.17	56.76	64.18	43.66	47.76	52.54	60.36
		LWB	46.09	52.11	57.48	66.04	43.96	49.87	55.21	63.86	40.70	46.22	51.55	60.31
	3500	TC	70.0	70.9	76.3	86.2	65.6	68.0	73.8	83.8	59.7	64.2	70.0	79.8
		SHC	70.0	68.1	56.8	37.5	65.6	61.3	51.6	35.4	59.7	53.3	45.7	33.0
		LDB	54.34	55.15	59.39	66.45	49.93	52.09	56.63	64.03	43.50	47.63	52.39	60.18
		LWB	46.01	52.03	57.37	65.92	43.87	49.79	55.10	63.72	40.62	46.10	51.42	60.14
95	2100	TC	63.4	63.5	67.6	75.8	59.8	60.9	65.7	74.0	54.9	57.8	62.8	71.1
		SHC	63.4	63.5	53.3	33.9	59.8	57.7	48.2	31.9	54.9	50.2	42.5	29.7
		LDB	56.74	56.84	60.66	67.73	52.58	53.68	58.16	65.57	46.46	49.52	54.32	62.13
		LWB	47.14	53.16	58.57	67.11	45.16	51.21	56.55	65.18	42.14	47.93	53.26	62.00
	2800	TC	64.3	64.5	68.8	77.5	60.5	61.9	66.8	75.5	55.3	58.5	63.7	72.4
		SHC	64.3	64.5	53.7	34.4	60.5	58.1	48.6	32.4	55.3	50.4	42.9	30.2
		LDB	56.44	56.48	60.53	67.54	52.26	53.49	57.99	65.34	46.21	49.36	54.11	61.85
		LWB	46.99	53.01	58.41	66.92	45.01	51.02	56.36	64.96	42.01	47.73	53.03	61.73
	3500	TC	64.8	65.0	69.6	78.6	61.0	62.4	67.5	76.5	55.7	59.0	64.3	73.3
		SHC	64.8	65.0	54.1	34.8	61.0	58.4	48.9	32.8	55.7	50.7	43.2	30.5
		LDB	56.23	56.29	60.39	67.40	52.05	53.36	57.84	65.18	45.99	49.20	53.93	61.66
		LWB	46.90	52.93	58.30	66.80	44.91	50.91	56.23	64.81	41.90	47.59	52.88	61.55
105	2100	TC	60.4	60.5	63.8	71.6	57.1	57.7	62.2	70.0	52.4	54.8	59.5	67.4
		SHC	60.4	60.5	51.8	32.5	57.1	56.0	46.7	30.5	52.4	48.7	41.1	28.3
		LDB	57.84	57.93	61.22	68.24	53.82	54.46	58.84	66.20	47.96	50.43	55.18	62.95
		LWB	47.64	53.62	59.08	67.59	45.76	51.83	57.17	65.77	42.90	48.76	54.07	62.78
	2800	TC	61.3	61.4	65.0	73.3	57.8	58.7	63.2	71.5	53.0	55.6	60.4	68.7
		SHC	61.3	61.4	52.1	33.0	57.8	56.5	47.1	31.0	53.0	49.1	41.4	28.8
		LDB	57.52	57.61	61.09	68.06	53.49	54.26	58.67	65.98	47.63	50.19	54.97	62.67
		LWB	47.50	53.48	58.92	67.40	45.61	51.63	56.99	65.55	42.73	48.52	53.85	62.51
	3500	TC	61.9	62.0	65.9	74.4	58.3	59.3	64.0	72.6	53.4	56.0	61.1	69.6
		SHC	61.9	62.0	52.5	33.4	58.3	56.8	47.4	31.4	53.4	49.3	41.8	29.2
		LDB	57.29	57.39	60.94	67.91	53.26	54.11	58.50	65.80	47.38	50.08	54.78	62.46
		LWB	47.39	53.39	58.80	67.27	45.49	51.53	56.85	65.40	42.61	48.42	53.68	62.32
115	2100	TC	57.3	57.3	59.9	67.3	54.2	54.3	58.4	65.8	49.9	51.5	56.1	63.6
		SHC	57.3	57.3	50.2	31.0	54.2	54.3	45.1	29.1	49.9	47.1	39.6	27.0
		LDB	59.00	59.09	61.79	68.77	55.15	55.22	59.53	66.84	49.53	51.38	56.07	63.77
		LWB	48.18	54.09	59.60	68.07	46.39	52.48	57.82	66.37	43.68	49.64	54.92	63.57
	2800	TC	58.3	58.3	61.2	68.9	55.1	55.4	59.6	67.4	50.6	52.4	57.1	64.9
		SHC	58.3	58.3	50.7	31.6	55.1	54.5	45.6	29.6	50.6	47.5	40.0	27.4
		LDB	58.63	58.72	61.62	68.58	54.76	55.16	59.33	66.61	49.11	51.15	55.82	63.49
		LWB	48.01	53.94	59.43	67.89	46.21	52.28	57.62	66.15	43.47	49.40	54.67	63.29
	3500	TC	58.8	58.8	62.0	69.9	55.5	55.9	60.2	68.3	50.9	52.8	57.6	65.7
		SHC	58.8	58.8	51.0	31.9	55.5	54.9	45.9	29.9	50.9	47.7	40.2	27.7
		LDB	58.45	58.54	61.49	68.46	54.58	54.99	59.21	66.47	48.92	51.03	55.69	63.32
		LWB	47.92	53.87	59.32	67.78	46.12	52.17	57.51	66.02	43.38	49.29	54.54	63.14

LEGEND

- BF — Bypass Factor
- ECT — Entering Condenser Temperature (F)
- EDB — Entering Dry Bulb (F)
- EWB — Entering Wet Bulb (F)
- LDB — Leaving Dry Bulb (F)
- LWB — Leaving Wet Bulb (F)
- SHC — Sensible Capacity (1000 Btu/hr)
- TC — Total Capacity (1000 Btu/hr)
- kW — Compressor Motor Power Input (kilowatts)

Performance data (cont)



GROSS COOLING CAPACITIES (cont)

50XA08 (7¹/₂ Tons)

Entering Condenser Air		BF	AIR ENTERING EVAPORATOR — 80 F Edb (F) - CFM											
ECT (F)	CFM		3750				3000				2250			
			Air Entering Evaporator — Ewb (F)											
			57	62	67	75	57	62	67	75	57	62	67	75
0.30	0.11	0.10	0.06	0.43	0.20	0.13	0.12	0.52	0.31	0.17	0.16			
55	2625	TC	95.1	95.4	100.9	113.5	89.6	91.1	98.1	110.8	82.1	86.4	93.8	106.4
		SHC	95.1	95.3	80.3	50.9	89.6	86.8	72.4	47.9	82.1	75.4	63.8	44.5
		LDB	56.76	56.81	60.59	67.72	52.61	53.61	58.11	65.58	46.56	49.48	54.30	62.17
		LWB	47.15	53.14	58.61	67.13	45.18	51.24	56.60	65.20	42.19	47.98	53.32	62.05
		KW	3.95	3.97	4.07	4.32	3.85	3.88	4.01	4.26	3.71	3.79	3.93	4.18
	3500	TC	96.1	96.2	102.4	115.5	90.4	92.1	99.5	112.7	82.7	87.1	94.9	108.1
		SHC	96.1	96.2	80.9	51.5	90.4	87.3	73.0	48.5	82.7	75.7	64.3	45.0
		LDB	56.51	56.61	60.44	67.57	52.37	53.47	57.94	65.40	46.31	49.36	54.11	61.94
		LWB	47.03	53.06	58.48	66.98	45.06	51.11	56.44	65.02	42.07	47.85	53.14	61.81
		KW	3.53	3.53	3.61	3.80	3.45	3.47	3.57	3.76	3.35	3.41	3.51	3.70
	4300	TC	96.5	96.7	103.1	116.6	90.8	92.5	100.0	113.6	83.0	87.5	95.3	108.8
		SHC	96.5	96.7	81.2	51.9	90.8	87.6	73.2	48.8	83.0	75.9	64.5	45.3
LDB		56.41	56.49	60.37	67.49	52.24	53.39	57.88	65.30	46.19	49.26	54.04	61.83	
LWB		46.98	53.02	58.42	66.90	45.00	51.06	56.38	64.93	42.01	47.77	53.07	61.71	
	KW	3.30	3.31	3.37	3.53	3.24	3.26	3.34	3.49	3.16	3.21	3.29	3.44	
75	2625	TC	88.9	89.0	93.2	105.0	84.0	84.5	90.8	102.6	77.2	80.1	87.0	98.8
		SHC	88.9	89.0	77.1	48.0	84.0	83.2	69.4	45.0	77.2	72.3	60.9	41.7
		LDB	58.27	58.36	61.34	68.43	54.32	54.72	59.01	66.44	48.53	50.72	55.49	63.28
		LWB	47.84	53.79	59.30	67.77	46.00	52.10	57.46	66.00	43.18	49.13	54.44	63.09
		KW	5.06	5.06	5.16	5.44	4.96	4.97	5.11	5.38	4.81	4.87	5.02	5.29
	3500	TC	89.9	89.9	94.7	106.8	84.8	85.5	92.0	104.3	77.8	81.0	88.0	100.3
		SHC	89.9	89.9	77.8	48.6	84.8	83.7	69.9	45.6	77.8	72.7	61.3	42.2
		LDB	58.04	58.13	61.18	68.29	54.08	54.56	58.89	66.27	48.30	50.54	55.32	63.08
		LWB	47.74	53.70	59.17	67.64	45.88	51.97	57.32	65.84	43.07	48.98	54.28	62.89
		KW	4.58	4.58	4.66	4.85	4.50	4.51	4.61	4.81	4.39	4.44	4.55	4.74
	4300	TC	90.4	90.5	95.4	107.9	85.3	86.0	92.7	105.3	78.1	81.3	88.6	101.1
		SHC	90.4	90.5	78.1	48.9	85.3	84.0	70.2	45.9	78.1	72.9	61.6	42.5
LDB		57.90	58.00	61.11	68.19	53.94	54.47	58.79	66.17	48.17	50.48	55.21	62.95	
LWB		47.67	53.64	59.11	67.55	45.82	51.90	57.24	65.74	43.00	48.91	54.18	62.78	
	KW	4.32	4.32	4.38	4.54	4.26	4.27	4.35	4.51	4.17	4.21	4.30	4.46	
95	2625	TC	82.1	82.2	84.7	95.4	77.8	77.9	82.6	93.4	71.8	73.4	79.7	90.3
		SHC	82.1	82.2	73.8	44.8	77.8	77.9	66.2	41.9	71.8	68.9	57.7	38.6
		LDB	59.93	60.01	62.15	69.19	56.21	56.31	60.00	67.37	50.75	52.08	56.74	64.49
		LWB	48.60	54.47	60.06	68.48	46.89	52.94	58.39	66.89	44.28	50.34	55.63	64.25
		KW	6.36	6.37	6.43	6.72	6.25	6.26	6.38	6.67	6.10	6.14	6.30	6.58
	3500	TC	82.9	83.0	86.1	97.1	78.5	78.5	83.8	95.0	72.2	74.1	80.4	91.7
		SHC	82.9	83.0	74.3	45.4	78.5	78.5	66.5	42.4	72.2	69.3	58.1	39.1
		LDB	59.73	59.82	62.02	69.06	56.03	56.13	59.89	67.21	50.58	51.93	56.61	64.30
		LWB	48.51	54.39	59.93	68.35	46.80	52.86	58.26	66.73	44.19	50.22	55.51	64.06
		KW	5.83	5.83	5.89	6.10	5.75	5.75	5.85	6.06	5.64	5.67	5.79	6.00
	4300	TC	83.5	83.6	86.9	98.2	79.0	79.1	84.5	96.0	72.6	74.5	81.1	92.6
		SHC	83.5	83.6	74.6	45.8	79.0	79.1	66.9	42.8	72.6	69.4	58.3	39.4
LDB		59.59	59.67	61.95	68.96	55.87	55.97	59.79	67.11	50.42	51.86	56.49	64.17	
LWB		48.45	54.33	59.87	68.27	46.73	52.80	58.18	66.63	44.12	50.16	55.41	63.94	
	KW	5.55	5.55	5.60	5.77	5.48	5.49	5.56	5.73	5.39	5.42	5.52	5.68	
105	2625	TC	78.3	78.3	80.2	90.2	74.4	74.4	78.2	88.6	68.7	69.5	75.6	85.8
		SHC	78.3	78.3	71.9	43.1	74.4	74.4	64.4	40.3	68.7	67.0	56.1	37.1
		LDB	60.86	60.95	62.61	69.60	57.28	57.38	60.54	67.84	52.00	52.86	57.39	65.10
		LWB	49.02	54.85	60.46	68.86	47.39	53.39	58.90	67.34	44.89	51.04	56.29	64.84
		KW	7.07	7.08	7.13	7.41	6.97	6.97	7.08	7.37	6.81	6.83	7.00	7.29
	3500	TC	79.1	79.1	81.6	91.9	75.0	75.1	79.5	90.0	69.2	70.4	76.3	87.0
		SHC	79.1	79.1	72.4	43.6	75.0	75.1	64.9	40.7	69.2	67.4	56.3	37.5
		LDB	60.67	60.75	62.49	69.47	57.09	57.18	60.39	67.72	51.82	52.71	57.31	64.95
		LWB	48.94	54.77	60.34	68.74	47.30	53.30	58.75	67.21	44.80	50.88	56.18	64.69
		KW	6.54	6.54	6.58	6.79	6.45	6.46	6.54	6.76	6.34	6.36	6.48	6.70
	4300	TC	79.7	79.8	82.3	93.0	75.5	75.6	80.0	91.0	69.6	70.8	76.9	87.9
		SHC	79.7	79.8	72.8	44.0	75.5	75.6	65.1	41.1	69.6	67.6	56.6	37.8
LDB		60.52	60.60	62.41	69.38	56.93	57.02	60.33	67.61	51.66	52.60	57.18	64.82	
LWB		48.87	54.71	60.27	68.66	47.22	53.24	58.69	67.11	44.72	50.80	56.07	64.57	
	KW	6.24	6.24	6.28	6.45	6.18	6.18	6.25	6.42	6.09	6.10	6.20	6.37	
115	2625	TC	74.1	74.1	75.4	84.8	70.5	70.5	73.6	83.2	65.3	65.6	71.0	80.7
		SHC	74.1	74.1	69.8	41.4	70.5	70.5	62.5	38.5	65.3	64.9	54.2	35.3
		LDB	61.90	61.98	63.11	70.03	58.47	58.56	61.10	68.39	53.40	53.68	58.15	65.81
		LWB	49.49	55.26	60.87	69.25	47.94	53.87	59.41	67.84	45.56	51.71	57.01	65.51
		KW	7.82	7.82	7.86	8.14	7.71	7.71	7.81	8.10	7.56	7.57	7.73	8.02
	3500	TC	75.0	75.1	76.7	86.3	71.2	71.3	74.8	84.7	65.9	66.5	71.9	82.0
		SHC	75.0	75.1	70.3	41.8	71.2	71.3	63.0	39.0	65.9	65.2	54.5	35.7
		LDB	61.66	61.74	62.99	69.91	58.24	58.33	60.96	68.25	53.17	53.57	58.03	65.64
		LWB	49.38	55.17	60.76	69.14	47.83	53.78	59.28	67.70	45.45	51.55	56.87	65.34
		KW	7.28	7.28	7.32	7.52	7.20	7.20	7.28	7.49	7.09	7.10	7.22	7.43
	4300	TC	75.7	75.7	77.4	87.4	71.8	71.8	75.5	85.7	66.3	66.9	72.5	82.9
		SHC	75.7	75.7	70.7	42.2	71.8	71.8	63.3	39.3	66.3	65.5	54.8	36.1
LDB		61.51	61.59	62.91	69.82	58.07	58.16	60.88	68.15	53.00	53.46	57.91	65.51	
LWB		49.31	55.10	60.70	69.06	47.75	53.71	59.20	67.61	45.37	51.48	56.76	65.22	
	KW	6.99	6.99	7.02	7.19	6.93	6.93	6.99	7.16	6.83	6.84	6.94	7.11	

LEGEND

- BF — Bypass Factor
- ECT — Entering Condenser Temperature (F)
- EDB — Entering Dry Bulb (F)
- EWB — Entering Wet Bulb (F)
- LDB — Leaving Dry Bulb (F)
- LWB — Leaving Wet Bulb (F)
- SHC — Sensible Capacity (1000 Btu/hr)
- TC — Total Capacity (1000 Btu/hr)
- KW — Compressor Motor Power Input (kilowatts)



GROSS COOLING CAPACITIES (cont)

50XA12 (10 TONS)

Entering Condenser Air		BF	AIR ENTERING EVAPORATOR — 80 F Edb (F) - CFM											
			5000				4000				3000			
ECT (F)	CFM		Air Entering Evaporator — Ewb (F)											
		57	62	67	75	57	62	67	75	57	62	67	75	
		0.23	0.06	0.05	0.03	0.37	0.13	0.08	0.06	0.46	0.23	0.11	0.10	
55	4800	TC	140.7	140.9	151.0	171.6	131.8	135.1	146.3	166.9	119.7	127.4	139.0	159.3
		SHC	140.7	140.9	117.2	75.7	131.8	125.6	105.3	71.0	119.7	108.2	92.4	65.8
		LDB	54.21	54.30	58.75	66.32	49.79	51.37	56.13	63.98	43.44	47.13	52.10	60.24
		LWB	45.94	52.09	57.48	65.97	43.81	49.88	55.21	63.77	40.59	46.26	51.54	60.18
	KW	5.93	5.93	6.09	6.42	5.80	5.85	6.02	6.34	5.62	5.74	5.91	6.22	
	6000	TC	141.6	141.8	152.6	173.7	132.5	136.0	147.7	168.7	120.2	128.2	140.0	160.8
		SHC	141.6	141.8	117.9	76.4	132.5	126.1	105.9	71.6	120.2	108.6	92.9	66.4
		LDB	54.03	54.13	58.62	66.19	49.62	51.26	56.00	63.83	43.27	47.01	51.96	60.07
		LWB	45.86	52.02	57.37	65.85	43.72	49.79	55.08	63.63	40.50	46.14	51.41	60.02
	KW	5.31	5.31	5.42	5.64	5.22	5.26	5.37	5.59	5.11	5.18	5.30	5.50	
	7600	TC	142.1	142.6	153.3	174.8	132.9	136.5	148.3	169.6	120.5	128.6	140.5	161.5
		SHC	142.1	141.3	118.1	76.4	132.9	126.3	106.2	71.9	120.5	108.8	93.1	66.6
LDB		53.95	54.23	58.57	66.13	49.54	51.21	55.94	63.76	43.18	46.95	51.89	59.99	
LWB		45.82	51.96	57.32	65.78	43.68	49.74	55.03	63.56	40.46	46.08	51.34	59.94	
KW	4.97	4.96	5.05	5.21	4.90	4.93	5.01	5.17	4.82	4.87	4.96	5.11		
75	4800	TC	131.8	132.0	140.0	159.5	123.7	125.4	135.8	155.2	112.6	118.3	129.3	148.5
		SHC	131.8	132.0	112.8	71.6	123.7	120.7	101.0	66.9	112.6	103.8	88.1	61.7
		LDB	55.83	55.93	59.54	67.05	51.65	52.50	57.11	64.88	45.59	48.47	53.38	61.44
		LWB	46.71	52.78	58.24	66.66	44.71	50.85	56.16	64.65	41.70	47.54	52.79	61.35
	KW	7.65	7.65	7.80	8.16	7.51	7.53	7.72	8.08	7.31	7.41	7.60	7.95	
	6000	TC	132.7	132.9	141.2	161.3	124.5	126.2	136.9	156.8	113.2	119.1	130.2	149.8
		SHC	132.7	132.9	113.3	72.2	124.5	121.1	101.4	67.5	113.2	104.2	88.5	62.2
		LDB	55.67	55.77	59.44	66.94	51.48	52.39	57.00	64.76	45.41	48.35	53.26	61.29
		LWB	46.63	52.71	58.15	66.56	44.63	50.77	56.06	64.53	41.61	47.43	52.67	61.21
	KW	6.94	6.94	7.03	7.28	6.84	6.86	6.98	7.22	6.72	6.78	6.91	7.14	
	7600	TC	133.2	133.3	141.9	162.1	124.9	126.7	137.5	157.6	113.5	119.5	130.7	150.5
		SHC	133.2	133.3	113.6	72.5	124.9	121.4	101.7	67.7	113.5	104.4	88.8	62.5
LDB		55.58	55.68	59.40	66.89	51.39	52.34	56.95	64.70	45.32	48.29	53.19	61.21	
LWB		46.59	52.68	58.11	66.52	44.59	50.72	56.01	64.47	41.56	47.38	52.61	61.14	
KW	6.53	6.54	6.60	6.78	6.47	6.48	6.57	6.74	6.38	6.43	6.51	6.68		
95	4800	TC	121.9	122.0	127.6	145.4	114.7	114.9	123.9	141.9	104.7	108.3	118.3	136.2
		SHC	121.9	122.0	107.9	67.0	114.7	114.9	96.2	62.4	104.7	98.9	83.5	57.3
		LDB	57.65	57.75	60.43	67.88	53.72	53.81	58.19	65.90	48.02	49.95	54.78	62.76
		LWB	47.56	53.54	59.08	67.46	45.71	51.89	57.21	65.63	42.92	48.94	54.16	62.64
	KW	9.68	9.68	9.80	10.18	9.53	9.53	9.72	10.10	9.32	9.39	9.60	9.98	
	6000	TC	122.8	122.9	128.7	147.1	115.4	115.6	124.9	143.3	105.3	109.1	119.2	137.4
		SHC	122.8	122.9	108.3	67.5	115.4	115.6	96.6	62.9	105.3	99.3	83.8	57.7
		LDB	57.49	57.59	60.36	67.78	53.55	53.65	58.10	65.79	47.83	49.83	54.67	62.63
		LWB	47.49	53.47	59.01	67.37	45.63	51.81	57.12	65.53	42.83	48.83	54.05	62.51
	KW	8.89	8.90	8.97	9.23	8.80	8.80	8.92	9.18	8.66	8.71	8.85	9.09	
	7600	TC	123.2	123.3	129.3	147.9	115.8	116.0	125.5	144.1	105.6	109.4	119.7	138.0
		SHC	123.2	123.3	108.5	67.8	115.8	116.0	96.8	63.1	105.6	99.5	84.0	58.0
LDB		57.42	57.51	60.31	67.73	53.47	53.56	58.06	65.74	47.74	49.77	54.61	62.56	
LWB		47.45	53.44	58.97	67.33	45.59	51.78	57.07	65.47	42.79	48.78	53.99	62.45	
KW	8.45	8.45	8.51	8.69	8.38	8.38	8.47	8.65	8.29	8.32	8.42	8.59		
105	4800	TC	116.5	116.6	120.9	137.9	109.8	109.9	117.5	134.6	100.4	102.9	112.5	129.4
		SHC	116.5	116.6	105.2	64.6	109.8	109.9	93.6	59.9	100.4	96.3	81.0	54.9
		LDB	58.64	58.73	60.93	68.32	54.84	54.94	58.78	66.45	49.32	50.73	55.53	63.47
		LWB	48.01	53.94	59.53	67.89	46.25	52.37	57.76	66.16	43.57	49.66	54.88	63.33
	KW	10.81	10.82	10.91	11.29	10.66	10.66	10.84	11.22	10.45	10.51	10.72	11.10	
	6000	TC	117.3	117.4	121.9	139.4	110.5	110.6	118.5	136.0	101.0	103.7	113.3	130.6
		SHC	117.3	117.4	105.6	65.1	110.5	110.6	94.0	60.4	101.0	96.6	81.3	55.3
		LDB	58.49	58.58	60.85	68.23	54.68	54.78	58.69	66.34	49.14	50.63	55.42	63.34
		LWB	47.95	53.88	59.46	67.80	46.17	52.30	57.68	66.06	43.48	49.56	54.78	63.21
	KW	10.00	10.00	10.07	10.33	9.90	9.91	10.02	10.28	9.77	9.81	9.95	10.20	
	7600	TC	117.7	117.8	122.5	140.1	110.8	111.0	119.0	136.7	101.3	104.0	113.7	131.2
		SHC	117.7	117.8	105.8	65.3	110.8	111.0	94.2	60.6	101.3	96.8	81.5	55.5
LDB		58.42	58.51	60.81	68.19	54.60	54.71	58.64	66.29	49.06	50.58	55.37	63.28	
LWB		47.91	53.85	59.42	67.76	46.13	52.26	57.64	66.01	43.44	49.52	54.73	63.15	
KW	9.54	9.54	9.59	9.77	9.47	9.47	9.55	9.74	9.37	9.40	9.50	9.68		
115	4800	TC	110.8	110.9	114.0	129.9	104.5	104.7	110.8	127.0	95.9	97.3	106.2	122.3
		SHC	110.8	110.9	102.3	62.0	104.5	104.7	90.9	57.4	95.9	93.5	78.4	52.4
		LDB	59.69	59.78	61.44	68.78	56.04	56.14	59.38	67.02	50.71	51.57	56.30	64.21
		LWB	48.49	54.37	59.99	68.33	46.81	52.87	58.34	66.71	44.26	50.42	55.64	64.05
	KW	12.01	12.01	12.08	12.47	11.86	11.87	12.01	12.40	11.66	11.70	11.90	12.29	
	6000	TC	111.6	111.7	114.9	131.3	105.2	105.3	111.7	128.2	96.3	97.9	107.0	123.4
		SHC	111.6	111.7	102.7	62.5	105.2	105.3	91.3	57.8	96.3	93.8	78.7	52.8
		LDB	59.55	59.63	61.38	68.70	55.90	56.00	59.31	66.92	50.58	51.50	56.21	64.10
		LWB	48.43	54.31	59.93	68.25	46.74	52.81	58.26	66.62	44.19	50.34	55.54	63.95
	KW	11.20	11.20	11.25	11.50	11.09	11.10	11.20	11.46	10.96	10.98	11.13	11.38	
	7600	TC	111.9	112.0	115.4	132.0	105.5	105.7	112.1	128.9	96.6	98.3	107.4	124.0
		SHC	111.9	112.0	102.9	62.7	105.5	105.7	91.5	58.1	96.6	94.0	78.9	53.0
LDB		59.48	59.56	61.34	68.66	55.82	55.91	59.26	66.88	50.48	51.44	56.15	64.04	
LWB		48.40	54.28	59.90	68.22	46.70	52.77	58.23	66.57	44.14	50.29	55.49	63.89	
KW	10.73	10.73	10.77	10.95	10.66	10.66	10.73	10.91	10.56	10.58	10.68	10.86		

LEGEND

- | | | |
|--|-----------------------------|---|
| BF — Bypass Factor | EWB — Entering Wet Bulb (F) | SHC — Sensible Capacity (1000 Btu/hr) |
| ECT — Entering Condenser Temperature (F) | LDB — Leaving Dry Bulb (F) | TC — Total Capacity (1000 Btu/hr) |
| EDB — Entering Dry Bulb (F) | LWB — Leaving Wet Bulb (F) | KW — Compressor Motor Power Input (kilowatts) |

Performance data (cont)



GROSS COOLING CAPACITIES (cont)

50XCA14 (12 TONS)														
Entering Condenser Air		BF	AIR ENTERING EVAPORATOR — 80 F Edb (F) - CFM											
			6000				4800				3600			
ECT (F)	CFM		Air Entering Evaporator — Ewb (F)											
		57	62	67	75	57	62	67	75	57	62	67	75	
		0.24	0.09	0.08	0.05	0.38	0.15	0.12	0.10	0.47	0.25	0.15	0.13	
55	6000	TC	165.3	166.3	178.4	202.5	155.0	159.4	172.8	196.7	141.0	150.5	164.0	187.6
		SHC	165.3	163.1	136.5	88.8	155.0	146.7	123.2	83.4	141.0	127.1	108.6	77.5
		LDB	54.74	55.21	59.37	66.62	50.40	52.14	56.73	64.30	44.09	47.82	52.68	60.60
		LWB	46.20	52.28	57.65	66.14	44.11	50.11	55.43	64.00	40.93	46.54	51.85	60.51
	kW	6.11	6.13	6.21	6.39	6.05	6.08	6.17	6.34	5.97	6.02	6.11	6.27	
	8000	TC	165.8	166.9	179.2	204.0	155.5	159.9	173.5	197.8	141.3	150.8	164.6	188.6
		SHC	165.8	163.7	136.8	89.3	155.5	147.0	123.5	83.8	141.3	127.2	108.8	77.8
		LDB	54.66	55.13	59.33	66.54	50.31	52.08	56.69	64.23	44.01	47.81	52.63	60.51
		LWB	46.17	52.24	57.60	66.07	44.07	50.07	55.38	63.93	40.89	46.51	51.79	60.42
	kW	5.51	5.51	5.54	5.62	5.48	5.49	5.53	5.60	5.45	5.47	5.50	5.57	
	9500	TC	166.2	167.2	179.7	204.6	155.8	160.2	174.0	198.5	141.6	151.2	165.0	189.2
		SHC	166.2	163.8	137.0	89.5	155.8	147.1	123.7	84.1	141.6	127.4	109.0	78.1
LDB		54.61	55.10	59.29	66.51	50.25	52.06	56.64	64.18	43.95	47.76	52.58	60.46	
LWB		46.14	52.22	57.57	66.04	44.04	50.05	55.34	63.88	40.86	46.47	51.75	60.37	
kW	5.24	5.24	5.26	5.32	5.23	5.24	5.25	5.30	5.22	5.22	5.24	5.28		
75	6000	TC	155.1	155.3	165.2	187.7	145.8	148.1	160.3	182.7	133.1	140.1	152.7	174.9
		SHC	155.1	155.3	131.2	83.8	145.8	141.1	118.0	78.5	133.1	122.0	103.6	72.7
		LDB	56.31	56.40	60.17	67.37	52.15	53.20	57.71	65.22	46.11	49.13	53.94	61.79
		LWB	46.94	52.99	58.41	66.85	44.96	51.05	56.36	64.88	41.97	47.77	53.05	61.65
	kW	8.16	8.16	8.24	8.44	8.09	8.11	8.21	8.39	8.00	8.05	8.14	8.33	
	8000	TC	155.7	155.9	166.0	189.0	146.3	148.9	161.0	183.8	133.4	140.6	153.3	175.8
		SHC	155.7	155.9	131.5	84.2	146.3	141.4	118.3	78.9	133.4	122.2	103.8	73.0
		LDB	56.22	56.30	60.13	67.30	52.06	53.15	57.66	65.14	46.02	49.08	53.87	61.70
		LWB	46.90	52.94	58.36	66.79	44.92	50.99	56.31	64.80	41.92	47.71	52.99	61.56
	kW	7.45	7.46	7.49	7.58	7.43	7.44	7.47	7.56	7.39	7.41	7.45	7.53	
	9500	TC	156.1	156.2	166.6	189.8	146.7	149.2	161.6	184.6	133.7	141.0	153.8	176.4
		SHC	156.1	156.2	131.8	84.5	146.7	141.5	118.5	79.2	133.7	122.4	104.0	73.3
LDB		56.15	56.26	60.09	67.26	51.99	53.12	57.61	65.09	45.95	49.02	53.82	61.64	
LWB		46.87	52.92	58.33	66.75	44.89	50.97	56.27	64.76	41.89	47.67	52.94	61.51	
kW	7.14	7.14	7.15	7.20	7.13	7.13	7.15	7.19	7.12	7.12	7.14	7.17		
95	6000	TC	143.5	143.6	150.6	171.0	135.3	135.9	146.4	166.9	124.1	127.8	140.0	160.6
		SHC	143.5	143.6	125.4	78.3	135.3	134.3	112.3	73.1	124.1	115.9	98.1	67.5
		LDB	58.08	58.17	61.05	68.19	54.17	54.48	58.78	66.22	48.39	50.65	55.31	63.08
		LWB	47.76	53.72	59.23	67.63	45.93	52.05	57.38	65.84	43.12	49.19	54.37	62.89
	kW	10.55	10.55	10.61	10.80	10.48	10.48	10.57	10.77	10.39	10.27	10.52	10.71	
	8000	TC	144.1	144.3	151.6	172.4	135.8	136.7	147.1	168.1	124.3	129.2	140.6	161.3
		SHC	144.1	144.3	125.8	78.7	135.8	134.6	112.6	73.5	124.3	116.6	98.3	67.7
		LDB	57.98	58.07	60.98	68.13	54.07	54.44	58.73	66.15	48.35	50.48	55.25	63.01
		LWB	47.71	53.68	59.17	67.57	45.88	51.98	57.33	65.77	43.10	49.02	54.31	62.83
	kW	9.79	9.79	9.82	9.90	9.76	9.77	9.80	9.88	9.73	9.74	9.78	9.85	
	9500	TC	144.6	144.8	152.1	173.3	136.2	137.0	147.7	168.9	124.7	129.4	141.2	162.0
		SHC	144.6	144.8	126.0	79.1	136.2	134.8	112.9	73.8	124.7	116.7	98.6	68.0
LDB		57.90	58.00	60.96	68.08	53.98	54.40	58.68	66.10	48.26	50.44	55.18	62.95	
LWB		47.68	53.65	59.15	67.53	45.84	51.96	57.28	65.72	43.05	49.00	54.25	62.77	
kW	9.44	9.44	9.45	9.49	9.43	9.43	9.44	9.48	9.43	9.43	9.44	9.47		
105	6000	TC	137.3	137.4	142.6	162.4	129.7	129.6	138.8	158.6	119.0	122.1	133.3	152.6
		SHC	137.3	137.4	122.2	75.6	129.7	129.6	109.3	70.4	119.0	113.2	95.4	64.7
		LDB	59.03	59.12	61.53	68.60	55.24	55.38	59.36	66.74	49.70	51.34	55.99	63.77
		LWB	48.20	54.11	59.68	68.04	46.44	52.56	57.93	66.34	43.77	49.83	55.05	63.57
	kW	11.85	11.85	11.90	12.09	11.78	11.78	11.87	12.05	11.68	11.71	11.82	12.00	
	8000	TC	137.7	137.8	143.7	163.6	130.0	130.3	139.5	159.4	119.2	122.8	133.6	153.3
		SHC	137.7	137.8	122.6	75.9	130.0	130.3	109.5	70.6	119.2	113.5	95.4	64.9
		LDB	58.96	59.05	61.47	68.56	55.18	55.24	59.31	66.70	49.65	51.27	55.99	63.72
		LWB	48.17	54.08	59.62	67.98	46.41	52.50	57.88	66.29	43.74	49.75	55.02	63.51
	kW	11.08	11.08	11.11	11.19	11.06	11.06	11.09	11.17	11.02	11.03	11.07	11.15	
	9500	TC	138.2	138.4	144.1	164.3	130.5	130.6	140.2	160.2	119.6	123.1	134.2	154.0
		SHC	138.2	138.4	122.8	76.1	130.5	130.6	109.8	70.9	119.6	113.6	95.6	65.1
LDB		58.88	58.97	61.44	68.52	55.09	55.19	59.25	66.65	49.54	51.23	55.92	63.66	
LWB		48.13	54.05	59.59	67.95	46.37	52.47	57.83	66.25	43.69	49.72	54.96	63.46	
kW	10.73	10.73	10.74	10.77	10.72	10.72	10.73	10.76	10.71	10.72	10.73	10.75		
115	6000	TC	130.4	130.5	134.2	152.8	123.4	123.5	130.6	149.5	113.4	115.2	125.4	144.1
		SHC	130.4	130.5	118.8	72.5	123.4	123.5	106.0	67.4	113.4	109.7	92.0	61.7
		LDB	60.08	60.16	62.04	69.07	56.44	56.54	59.97	67.31	51.12	52.21	56.84	64.51
		LWB	48.67	54.53	60.14	68.48	47.00	53.04	58.51	66.89	44.46	50.60	55.85	64.28
	kW	13.18	13.18	13.22	13.39	13.12	13.12	13.18	13.36	13.02	13.04	13.14	13.31	
	8000	TC	130.8	130.9	135.3	154.0	123.7	123.8	131.6	150.2	113.6	116.0	126.1	144.8
		SHC	130.8	130.9	119.2	72.8	123.7	123.8	106.4	67.5	113.6	110.0	92.2	61.9
		LDB	60.02	60.10	61.98	69.03	56.39	56.48	59.89	67.28	51.07	52.13	56.78	64.47
		LWB	48.65	54.51	60.08	68.43	46.98	53.02	58.44	66.85	44.44	50.51	55.78	64.23
	kW	12.45	12.45	12.47	12.54	12.42	12.42	12.45	12.52	12.38	12.39	12.43	12.50	
	9500	TC	131.4	131.5	135.8	154.5	124.2	124.3	132.1	151.0	114.0	116.3	126.7	145.4
		SHC	131.4	131.5	119.4	73.0	124.2	124.3	106.6	67.8	114.0	110.2	92.5	62.1
LDB		59.93	60.01	61.95	69.00	56.29	56.39	59.86	67.23	50.96	52.09	56.70	64.41	
LWB		48.61	54.47	60.05	68.40	46.93	52.98	58.41	66.80	44.39	50.48	55.72	64.18	
kW	12.10	12.10	12.11	12.13	12.10	12.10	12.11	12.13	12.08	12.09	12.10	12.12		

LEGEND

BF — Bypass Factor	EWB — Entering Wet Bulb (F)	SHC — Sensible Capacity (1000 Btu/hr)
ECT — Entering Condenser Temperature (F)	LDB — Leaving Dry Bulb (F)	TC — Total Capacity (1000 Btu/hr)
Edb — Entering Dry Bulb (F)	LWB — Leaving Wet Bulb (F)	kW — Compressor Motor Power Input (kilowatts)



CONDENSER FAN PERFORMANCE

50XCA06 (5 Tons)

CFM	ESP (in. wg)											
	0.00		0.10		0.20		0.30		0.40		0.50	
	Rpm	Bhp	Rpm	Bhp	Rpm	Bhp	Rpm	Bhp	Rpm	Bhp	Rpm	Bhp
1800	594	0.19	594	0.19	594	0.19	676	0.25	755	0.33	828	0.42
1900	588	0.19	588	0.19	598	0.20	686	0.27	764	0.35	836	0.44
2000	582	0.19	582	0.19	610	0.21	696	0.29	773	0.37	844	0.46
2100	576	0.19	576	0.19	623	0.23	707	0.31	783	0.40	852	0.49
2200	570	0.20	570	0.20	636	0.25	718	0.33	793	0.42	861	0.51
2300	564	0.20	564	0.20	649	0.27	730	0.36	803	0.44	870	0.54
2400	558	0.20	573	0.22	662	0.29	742	0.38	814	0.47	880	0.57
2500	552	0.21	589	0.24	676	0.32	754	0.41	825	0.50	890	0.60
2600	546	0.21	605	0.26	690	0.34	766	0.43	836	0.53	901	0.63
2600	540	0.21	622	0.28	704	0.37	779	0.46	848	0.56	911	0.66
2800	550	0.23	638	0.31	719	0.40	792	0.49	860	0.59	923	0.70
2900	570	0.26	655	0.34	734	0.43	806	0.53	872	0.63	934	0.74
3000	590	0.29	672	0.37	749	0.46	819	0.56	885	0.67	946	0.78

50XCA06 (5 Tons) (cont)

CFM	ESP (in. wg)											
	0.60		0.70		0.80		0.90		1.00		1.10	
	Rpm	Bhp	Rpm	Bhp	Rpm	Bhp	Rpm	Bhp	Rpm	Bhp	Rpm	Bhp
1800	896	0.51	960	0.61	1020	0.72	—	—	—	—	—	—
1900	902	0.54	965	0.64	1025	0.74	1082	0.86	—	—	—	—
2000	909	0.56	971	0.66	1030	0.77	1086	0.88	1140	1.00	—	—
2100	917	0.58	978	0.69	1036	0.80	1091	0.91	1145	1.03	1196	1.16
2200	925	0.61	985	0.72	1042	0.83	1097	0.94	1150	1.06	1201	1.19
2300	933	0.64	993	0.75	1049	0.86	1103	0.98	1155	1.10	1206	1.22
2400	942	0.67	1001	0.78	1057	0.89	1110	1.01	1162	1.13	1211	1.26
2500	951	0.70	1009	0.81	1065	0.93	1117	1.05	1168	1.17	1217	1.30
2600	961	0.74	1018	0.85	1073	0.96	1125	1.09	1175	1.21	1224	1.34
2700	971	0.77	1028	0.89	1081	1.00	1133	1.13	1183	1.25	1231	1.39
2800	982	0.81	1037	0.93	1090	1.05	1141	1.17	1191	1.30	1238	1.43
2900	992	0.85	1047	0.97	1100	1.09	1150	1.21	1199	1.34	1246	1.48
3000	1003	0.89	1058	1.01	1110	1.13	1159	1.26	1207	1.39	—	—

LEGEND

Bhp — Brake Horsepower
ESP — External Static Pressure

NOTES:

- Units are available with several motor hp options. Refer to Physical Data table.
- Static pressure losses for any options or accessories must be applied to external static pressure before entering the fan performance table.

- Interpolation is permitted; extrapolation is not.
- Fan performance is based on unit casing, and dry DX (direct expansion) coil losses at sea level.

Performance data (cont)



CONDENSER FAN PERFORMANCE (cont)

50XCA08 (7 1/2 Tons)																
CFM	ESP (in. wg)															
	0.00		0.10		0.20		0.30		0.40		0.50		0.60		0.70	
	Rpm	Bhp	Rpm	Bhp	Rpm	Bhp	Rpm	Bhp	Rpm	Bhp	Rpm	Bhp	Rpm	Bhp	Rpm	Bhp
2500	594	0.25	594	0.25	662	0.32	738	0.41	807	0.50	872	0.60	932	0.70	988	0.81
2650	588	0.26	600	0.27	682	0.36	757	0.45	824	0.55	887	0.65	946	0.75	1001	0.87
2800	582	0.27	625	0.31	704	0.40	776	0.49	842	0.59	903	0.70	961	0.81	1016	0.93
2950	576	0.28	650	0.35	726	0.45	795	0.54	860	0.65	920	0.76	977	0.87	1030	0.99
3100	597	0.31	675	0.40	748	0.50	816	0.60	879	0.71	938	0.82	993	0.94	1046	1.06
3250	625	0.36	700	0.45	771	0.55	836	0.66	898	0.77	956	0.88	1010	1.00	1062	1.13
3400	654	0.42	726	0.51	794	0.61	858	0.72	918	0.83	974	0.95	1027	1.08	1078	1.21
3550	683	0.47	752	0.57	818	0.68	879	0.79	938	0.91	993	1.03	1045	1.16	1095	1.29
3700	712	0.54	778	0.64	842	0.75	901	0.86	958	0.98	1012	1.11	1064	1.24	1113	1.37
3850	741	0.60	805	0.71	866	0.82	924	0.94	979	1.06	1032	1.19	1083	1.33	1131	1.47
4000	770	0.68	831	0.79	890	0.90	947	1.02	1001	1.15	1053	1.29	1102	1.42	1150	1.56
4150	799	0.75	858	0.87	915	0.99	970	1.11	1023	1.25	1073	1.38	1122	1.52	1168	1.67
4300	828	0.84	885	0.96	940	1.08	994	1.21	1045	1.34	1094	1.49	1142	1.63	1188	1.78
4450	856	0.93	912	1.05	966	1.18	1017	1.31	1068	1.45	1116	1.59	1162	1.74	1207	1.89
4600	885	1.03	939	1.15	991	1.28	1042	1.42	1090	1.56	1138	1.71	1183	1.86	—	—

50XCA08 (7 1/2 Tons) (cont)																
CFM	ESP (in. wg)															
	0.80		0.90		1.00		1.10		1.20		1.30		1.40			
	Rpm	Bhp	Rpm	Bhp	Rpm	Bhp	Rpm	Bhp	Rpm	Bhp	Rpm	Bhp	Rpm	Bhp		
2500	1042	0.93	1094	1.05	1144	1.17	1192	1.30	1238	1.43	1283	1.57	1327	1.72		
2650	1055	0.98	1105	1.11	1154	1.23	1201	1.36	1247	1.50	1291	1.64	1334	1.78		
2800	1068	1.05	1117	1.17	1166	1.30	1212	1.43	1257	1.57	1301	1.71	1343	1.86		
2950	1081	1.11	1131	1.24	1178	1.37	1224	1.50	1268	1.64	1311	1.79	1353	1.94		
3100	1096	1.18	1144	1.31	1191	1.44	1236	1.58	1279	1.72	1322	1.87	—	—		
3250	1111	1.26	1159	1.39	1205	1.53	1249	1.67	1292	1.81	1334	1.96	—	—		
3400	1127	1.34	1174	1.47	1219	1.61	1263	1.75	1305	1.90	—	—	—	—		
3550	1143	1.42	1189	1.56	1234	1.70	1277	1.85	1319	2.00	—	—	—	—		
3700	1160	1.51	1206	1.65	1249	1.80	1292	1.95	—	—	—	—	—	—		
3850	1178	1.61	1222	1.75	1265	1.90	—	—	—	—	—	—	—	—		
4000	1195	1.71	1239	1.86	—	—	—	—	—	—	—	—	—	—		
4150	1213	1.82	1257	1.97	—	—	—	—	—	—	—	—	—	—		
4300	1232	1.93	—	—	—	—	—	—	—	—	—	—	—	—		
4450	—	—	—	—	—	—	—	—	—	—	—	—	—	—		
4600	—	—	—	—	—	—	—	—	—	—	—	—	—	—		

LEGEND

Bhp — Brake Horsepower
ESP — External Static Pressure

NOTES:

- Units are available with several motor hp options. Refer to Physical Data table.
- Static pressure losses for any options or accessories must be applied to external static pressure before entering the fan performance table.

- Interpolation is permitted; extrapolation is not.
- Fan performance is based on unit casing, and dry DX (direct expansion) coil losses at sea level.



CONDENSER FAN PERFORMANCE (cont)

50XCA12 (10 Tons)																
CFM	ESP (in. wg)															
	0.00		0.10		0.20		0.30		0.40		0.50		0.60		0.70	
	Rpm	Bhp	Rpm	Bhp	Rpm	Bhp	Rpm	Bhp	Rpm	Bhp	Rpm	Bhp	Rpm	Bhp	Rpm	Bhp
4100	427	0.58	476	0.70	526	0.83	570	0.96	610	1.09	648	1.23	684	1.36	720	1.51
4300	448	0.67	494	0.79	543	0.93	586	1.07	625	1.21	662	1.34	697	1.49	731	1.63
4500	468	0.76	512	0.89	559	1.04	602	1.18	640	1.33	676	1.47	710	1.62	744	1.77
4700	489	0.87	531	1.00	576	1.15	618	1.31	655	1.46	691	1.61	724	1.76	757	1.91
4900	510	0.98	550	1.12	594	1.28	634	1.44	671	1.60	706	1.75	738	1.91	770	2.07
5100	531	1.11	569	1.25	611	1.41	651	1.58	687	1.75	721	1.91	753	2.07	784	2.24
5300	552	1.25	588	1.39	628	1.56	667	1.74	703	1.91	736	2.08	768	2.24	798	2.41
5500	572	1.39	607	1.54	646	1.71	684	1.90	719	2.08	752	2.25	783	2.43	813	2.60
5700	593	1.55	626	1.70	664	1.88	701	2.07	736	2.26	768	2.44	798	2.62	828	2.80
5900	614	1.72	646	1.87	682	2.06	718	2.25	752	2.45	784	2.64	814	2.83	843	3.01
6100	635	1.90	665	2.06	700	2.25	735	2.45	769	2.65	800	2.85	830	3.04	858	3.24
6300	656	2.09	685	2.25	719	2.45	753	2.66	786	2.87	817	3.07	846	3.27	874	3.47
6500	676	2.30	705	2.46	737	2.66	770	2.88	803	3.09	833	3.30	862	3.51	889	3.72
6700	697	2.52	725	2.69	756	2.89	788	3.11	820	3.33	850	3.55	878	3.77	905	3.98
6900	718	2.75	744	2.92	774	3.13	806	3.35	837	3.58	866	3.81	894	4.03	921	4.26

50XCA12 (10 Tons) (cont)												
CFM	ESP (in. wg)											
	0.80		0.90		1.00		1.10		1.20		1.30	
	Rpm	Bhp	Rpm	Bhp	Rpm	Bhp	Rpm	Bhp	Rpm	Bhp	Rpm	Bhp
4100	—	—	—	—	—	—	—	—	—	—	—	—
4300	765	1.79	—	—	—	—	—	—	—	—	—	—
4500	776	1.92	—	—	—	—	—	—	—	—	—	—
4700	788	2.07	819	2.24	—	—	—	—	—	—	—	—
4900	801	2.23	831	2.40	860	2.57	—	—	—	—	—	—
5100	814	2.40	843	2.58	872	2.75	900	2.93	—	—	—	—
5300	827	2.59	856	2.76	884	2.94	912	3.13	939	3.31	—	—
5500	841	2.78	869	2.96	896	3.14	923	3.33	950	3.52	976	3.72
5700	856	2.99	883	3.17	910	3.36	936	3.55	962	3.74	987	3.94
5900	870	3.20	897	3.39	923	3.58	949	3.78	974	3.98	999	4.18
6100	885	3.43	911	3.63	937	3.82	962	4.02	987	4.23	1011	4.43
6300	900	3.67	926	3.87	951	4.08	976	4.28	1000	4.49	1024	4.70
6500	916	3.93	941	4.14	966	4.34	990	4.55	1014	4.76	1037	4.98
6700	931	4.20	956	4.41	981	4.62	1004	4.84	—	—	—	—
6900	947	4.48	972	4.70	996	4.91	—	—	—	—	—	—

LEGEND

Bhp — Brake Horsepower
ESP — External Static Pressure

NOTES:

- Units are available with several motor hp options. Refer to Physical Data table.
- Static pressure losses for any options or accessories must be applied to external static pressure before entering the fan performance table.
- Interpolation is permitted; extrapolation is not.
- Fan performance is based on unit casing, and dry DX (direct expansion) coil losses at sea level.

Performance data (cont)



CONDENSER FAN PERFORMANCE (cont)

50XCA14 (12 Tons)																
CFM	ESP (in. wg)															
	0.00		0.10		0.20		0.30		0.40		0.50		0.60		0.70	
	Rpm	Bhp	Rpm	Bhp	Rpm	Bhp	Rpm	Bhp	Rpm	Bhp	Rpm	Bhp	Rpm	Bhp	Rpm	Bhp
6000	494	1.50	494	1.50	494	1.50	494	1.50	494	1.50	521	1.68	554	1.93	586	2.18
6250	488	1.52	488	1.52	488	1.52	488	1.52	494	1.56	528	1.80	561	2.05	592	2.30
6500	482	1.53	482	1.53	482	1.53	482	1.53	502	1.67	536	1.92	568	2.17	599	2.44
6750	476	1.55	476	1.55	476	1.55	477	1.56	511	1.79	544	2.05	576	2.31	606	2.58
7000	470	1.56	470	1.56	470	1.56	488	1.68	520	1.93	552	2.18	583	2.45	613	2.73
7250	464	1.58	464	1.58	466	1.59	498	1.82	530	2.07	561	2.33	591	2.60	621	2.88
7500	458	1.59	458	1.59	477	1.73	509	1.96	540	2.21	570	2.48	600	2.76	628	3.04
7750	452	1.61	459	1.66	489	1.88	519	2.12	549	2.37	579	2.64	608	2.92	636	3.22
8000	446	1.62	472	1.81	501	2.04	530	2.28	560	2.54	588	2.81	617	3.10	644	3.40
8250	458	1.77	485	1.97	513	2.20	542	2.45	570	2.71	598	2.99	626	3.28	653	3.59
8500	472	1.93	498	2.14	526	2.38	553	2.63	580	2.90	608	3.18	635	3.48	661	3.79
8750	486	2.11	512	2.33	538	2.56	564	2.82	591	3.09	618	3.38	644	3.68	670	4.00
9000	500	2.29	525	2.52	550	2.76	576	3.02	602	3.30	628	3.59	654	3.90	679	4.22
9250	514	2.49	538	2.72	563	2.97	588	3.23	613	3.52	638	3.81	663	4.13	688	4.45
9500	528	2.70	551	2.93	575	3.19	600	3.46	624	3.74	649	4.05	673	4.36	697	4.69

50XCA14 (12 Tons) (cont)																
CFM	ESP (in. wg)															
	0.80		0.90		1.00		1.10		1.20		1.30		1.40			
	Rpm	Bhp	Rpm	Bhp	Rpm	Bhp	Rpm	Bhp	Rpm	Bhp	Rpm	Bhp	Rpm	Bhp		
6000	616	2.43	644	2.69	671	2.96	697	3.23	722	3.50	746	3.78	768	4.06		
6250	622	2.57	650	2.84	677	3.11	703	3.39	728	3.67	751	3.95	774	4.24		
6500	628	2.71	656	2.98	683	3.27	709	3.55	734	3.84	757	4.13	780	4.43		
6750	635	2.86	663	3.14	689	3.43	715	3.72	739	4.02	763	4.32	786	4.62		
7000	642	3.01	669	3.30	696	3.60	721	3.90	745	4.20	769	4.51	792	4.82		
7250	649	3.17	676	3.47	702	3.77	727	4.08	752	4.39	775	4.71	—	—		
7500	656	3.34	683	3.65	709	3.96	734	4.27	758	4.59	781	4.91	—	—		
7750	663	3.52	690	3.83	715	4.15	740	4.47	764	4.80	—	—	—	—		
8000	671	3.71	697	4.02	722	4.35	747	4.67	—	—	—	—	—	—		
8250	679	3.90	705	4.22	730	4.55	754	4.89	—	—	—	—	—	—		
8500	687	4.11	712	4.44	737	4.77	—	—	—	—	—	—	—	—		
8750	695	4.32	720	4.66	744	5.00	—	—	—	—	—	—	—	—		
9000	704	4.55	728	4.89	—	—	—	—	—	—	—	—	—	—		
9250	712	4.98	—	—	—	—	—	—	—	—	—	—	—	—		
9500	—	—	—	—	—	—	—	—	—	—	—	—	—	—		

LEGEND

Bhp — Brake Horsepower
ESP — External Static Pressure

NOTES:

- Units are available with several motor hp options. Refer to Physical Data table.
- Static pressure losses for any options or accessories must be applied to external static pressure before entering the fan performance table.
- Interpolation is permitted; extrapolation is not.
- Fan performance is based on unit casing, and dry DX (direct expansion) coil losses at sea level.



CONDENSER FAN PERFORMANCE (cont)

50XCA16 (15 Tons)

CFM	ESP (in. wg)															
	0.00		0.10		0.20		0.30		0.40		0.50		0.60		0.70	
	Rpm	Bhp	Rpm	Bhp	Rpm	Bhp	Rpm	Bhp	Rpm	Bhp	Rpm	Bhp	Rpm	Bhp	Rpm	Bhp
6250	494	1.56	494	1.56	494	1.56	494	1.56	494	1.56	528	1.80	561	2.05	592	2.30
6500	488	1.57	488	1.57	488	1.57	488	1.57	502	1.67	536	1.92	568	2.17	599	2.44
6750	482	1.59	482	1.59	482	1.59	482	1.59	511	1.79	544	2.05	576	2.31	606	2.58
7000	476	1.61	476	1.61	476	1.61	488	1.68	520	1.93	552	2.18	583	2.45	613	2.73
7250	470	1.62	470	1.62	470	1.62	498	1.82	530	2.07	561	2.33	591	2.60	621	2.88
7500	464	1.64	464	1.64	477	1.73	509	1.96	540	2.21	570	2.48	600	2.76	628	3.04
7750	458	1.65	459	1.66	489	1.88	519	2.12	549	2.37	579	2.64	608	2.92	636	3.22
8000	452	1.67	472	1.81	501	2.04	530	2.28	560	2.54	588	2.81	617	3.10	644	3.40
8250	458	1.77	485	1.97	513	2.20	542	2.45	570	2.71	598	2.99	626	3.28	653	3.59
8500	472	1.93	498	2.14	526	2.38	553	2.63	580	2.90	608	3.18	635	3.48	661	3.79
8750	486	2.11	512	2.33	538	2.56	564	2.82	591	3.09	618	3.38	644	3.68	670	4.00
9000	500	2.29	525	2.52	550	2.76	576	3.02	602	3.30	628	3.59	654	3.90	679	4.22
9250	514	2.49	538	2.72	563	2.97	588	3.23	613	3.52	638	3.81	663	4.13	688	4.45
9500	528	2.70	551	2.93	575	3.19	600	3.46	624	3.74	649	4.05	673	4.36	697	4.69
9750	542	2.92	564	3.16	588	3.42	612	3.69	635	3.98	659	4.29	683	4.61	707	4.94

50XCA16 (15 Tons) (cont)

CFM	ESP (in. wg)													
	0.80		0.90		1.00		1.10		1.20		1.30		1.40	
	Rpm	Bhp	Rpm	Bhp	Rpm	Bhp	Rpm	Bhp	Rpm	Bhp	Rpm	Bhp	Rpm	Bhp
6250	622	2.57	650	2.84	677	3.11	703	3.39	728	3.67	751	3.95	774	4.24
6500	628	2.71	656	2.98	683	3.27	709	3.55	734	3.84	757	4.13	780	4.43
6750	635	2.86	663	3.14	689	3.43	715	3.72	739	4.02	763	4.32	786	4.62
7000	642	3.01	669	3.30	696	3.60	721	3.90	745	4.20	769	4.51	792	4.82
7250	649	3.17	676	3.47	702	3.77	727	4.08	752	4.39	775	4.71	—	—
7500	656	3.34	683	3.65	709	3.96	734	4.27	758	4.59	781	4.91	—	—
7750	663	3.52	690	3.83	715	4.15	740	4.47	764	4.80	—	—	—	—
8000	671	3.71	697	4.02	722	4.35	747	4.67	—	—	—	—	—	—
8250	679	3.90	705	4.22	730	4.55	754	4.89	—	—	—	—	—	—
8500	687	4.11	712	4.44	737	4.77	—	—	—	—	—	—	—	—
8750	695	4.32	720	4.66	744	5.00	—	—	—	—	—	—	—	—
9000	704	4.55	728	4.89	—	—	—	—	—	—	—	—	—	—
9250	712	4.78	—	—	—	—	—	—	—	—	—	—	—	—
9500	—	—	—	—	—	—	—	—	—	—	—	—	—	—
9750	—	—	—	—	—	—	—	—	—	—	—	—	—	—

LEGEND

Bhp — Brake Horsepower
ESP — External Static Pressure

NOTES:

- Units are available with several motor hp options. Refer to Physical Data table.
- Static pressure losses for any options or accessories must be applied to external static pressure before entering the fan performance table.
- Interpolation is permitted; extrapolation is not.
- Fan performance is based on unit casing, and dry DX (direct expansion) coil losses at sea level.

Performance data (cont)



CONDENSER FAN PERFORMANCE (cont)

50XCA24 (20 Tons)																
CFM	ESP (in. wg)															
	0.00		0.10		0.20		0.30		0.40		0.50		0.60		0.70	
	Rpm	Bhp	Rpm	Bhp	Rpm	Bhp	Rpm	Bhp	Rpm	Bhp	Rpm	Bhp	Rpm	Bhp	Rpm	Bhp
8,500	594	1.60	636	1.84	682	2.14	724	2.44	764	2.74	801	3.04	837	3.35	870	3.66
8,800	606	1.72	655	2.02	700	2.33	741	2.64	780	2.95	817	3.27	852	3.58	885	3.90
9,100	626	1.90	674	2.22	718	2.54	758	2.85	797	3.18	833	3.50	867	3.82	900	4.15
9,400	647	2.09	693	2.42	736	2.75	776	3.08	813	3.41	849	3.74	882	4.08	915	4.41
9,700	668	2.30	713	2.64	754	2.98	793	3.32	830	3.66	865	4.00	898	4.35	930	4.69
10,000	688	2.52	732	2.87	773	3.22	811	3.57	847	3.92	881	4.27	914	4.63	945	4.99
10,300	709	2.75	752	3.11	791	3.47	829	3.83	864	4.20	898	4.56	930	4.92	961	5.29
10,600	730	3.00	771	3.37	810	3.74	846	4.11	881	4.49	914	4.86	946	5.23	976	5.61
10,900	750	3.26	791	3.64	829	4.02	864	4.41	898	4.79	931	5.17	962	5.56	992	5.95
11,200	771	3.54	810	3.93	847	4.32	882	4.71	916	5.11	948	5.50	979	5.90	1008	6.29
11,500	792	3.83	830	4.23	866	4.64	901	5.04	933	5.44	965	5.85	995	6.25	1024	6.66
11,800	812	4.14	850	4.55	885	4.96	919	5.38	951	5.79	982	6.21	1012	6.62	1041	7.04
12,100	833	4.46	869	4.88	904	5.31	937	5.73	969	6.16	999	6.58	1029	7.01	1057	7.43
12,400	854	4.80	889	5.24	923	5.67	956	6.10	987	6.54	1017	6.97	1046	7.41	1074	7.85
12,700	874	5.16	909	5.60	942	6.05	974	6.49	1005	6.94	1034	7.38	1063	7.83	1090	8.28

50XCA24 (20 Tons) (cont)

CFM	ESP (in. wg)													
	0.80		0.90		1.00		1.10		1.20		1.30		1.40	
	Rpm	Bhp	Rpm	Bhp	Rpm	Bhp	Rpm	Bhp	Rpm	Bhp	Rpm	Bhp	Rpm	Bhp
8,500	902	3.97	933	4.28	963	4.59	992	4.91	1020	5.22	1046	5.54	1073	5.87
8,800	917	4.22	947	4.54	976	4.86	1005	5.19	1032	5.51	1059	5.84	1085	6.17
9,100	931	4.48	961	4.81	990	5.14	1018	5.48	1046	5.81	1072	6.15	1098	6.49
9,400	946	4.75	975	5.09	1004	5.44	1032	5.78	1059	6.13	1085	6.48	1111	6.83
9,700	960	5.04	990	5.39	1018	5.74	1046	6.10	1072	6.45	1098	6.81	1124	7.17
10,000	975	5.34	1004	5.70	1032	6.07	1060	6.43	1086	6.80	1112	7.16	1137	7.53
10,300	990	5.66	1019	6.03	1047	6.40	1074	6.77	1100	7.15	1126	7.53	1150	7.91
10,600	1006	5.99	1034	6.37	1062	6.75	1088	7.13	1114	7.52	1139	7.91	1164	8.29
10,900	1021	6.33	1049	6.72	1076	7.11	1103	7.51	1128	7.90	1153	8.30	1178	8.70
11,200	1037	6.69	1064	7.09	1091	7.49	1117	7.90	1143	8.30	1168	8.71	1192	9.11
11,500	1053	7.07	1080	7.48	1106	7.89	1132	8.30	1157	8.71	1182	9.13	1206	9.55
11,800	1069	7.46	1096	7.88	1122	8.30	1147	8.72	1172	9.15	1196	9.57	1220	10.00
12,100	1085	7.86	1111	8.29	1137	8.73	1162	9.16	1187	9.59	—	—	—	—
12,400	1101	8.29	1127	8.73	1153	9.17	1178	9.61	—	—	—	—	—	—
12,700	1117	8.73	1143	9.18	1169	9.63	—	—	—	—	—	—	—	—

LEGEND

Bhp — Brake Horsepower
ESP — External Static Pressure

NOTES:

- Units are available with several motor hp options. Refer to Physical Data table.
- Static pressure losses for any options or accessories must be applied to external static pressure before entering the fan performance table.
- Interpolation is permitted; extrapolation is not.
- Fan performance is based on unit casing, and dry DX (direct expansion) coil losses at sea level.



EVAPORATOR FAN PERFORMANCE

50XCA06 (5 Tons)																				
CFM	ESP (in. wg)																			
	0.00		0.10		0.20		0.30		0.40		0.50		0.60		0.70		0.80		0.90	
	Rpm	Bhp	Rpm	Bhp	Rpm	Bhp	Rpm	Bhp	Rpm	Bhp	Rpm	Bhp	Rpm	Bhp	Rpm	Bhp	Rpm	Bhp	Rpm	Bhp
1500	594	0.23	594	0.23	594	0.23	612	0.24	670	0.29	727	0.34	785	0.40	842	0.46	897	0.53	950	0.60
1600	588	0.24	588	0.24	588	0.24	630	0.28	684	0.32	738	0.37	793	0.43	847	0.49	900	0.56	952	0.64
1700	582	0.26	582	0.26	596	0.27	650	0.31	701	0.36	752	0.41	803	0.47	854	0.53	905	0.60	955	0.67
1800	576	0.28	576	0.28	618	0.31	670	0.36	719	0.40	767	0.45	815	0.51	863	0.57	911	0.64	959	0.71
1900	570	0.29	586	0.31	641	0.35	691	0.40	738	0.45	784	0.50	829	0.56	875	0.62	920	0.69	966	0.76
2000	564	0.31	612	0.35	664	0.40	712	0.45	757	0.50	801	0.56	845	0.61	888	0.67	931	0.74	975	0.81
2100	593	0.36	637	0.40	687	0.46	734	0.51	778	0.56	820	0.61	862	0.67	903	0.73	944	0.80	985	0.87
2200	621	0.42	663	0.46	710	0.51	756	0.57	799	0.62	840	0.68	879	0.74	919	0.80	958	0.86	997	0.93
2300	649	0.48	689	0.52	734	0.58	779	0.63	820	0.69	860	0.75	898	0.81	936	0.87	974	0.93	1011	1.00
2400	677	0.54	715	0.59	759	0.64	801	0.70	842	0.76	880	0.82	918	0.88	954	0.95	990	1.01	1026	1.08
2500	705	0.61	742	0.66	783	0.72	824	0.78	864	0.84	902	0.90	938	0.97	973	1.03	1008	1.10	1043	1.17

50XCA06 (5 Tons) (cont)																				
CFM	ESP (in. wg)																			
	1.00		1.10		1.20		1.30		1.40		1.50		1.60		1.70		1.80		1.90	
	Rpm	Bhp	Rpm	Bhp	Rpm	Bhp	Rpm	Bhp	Rpm	Bhp	Rpm	Bhp	Rpm	Bhp	Rpm	Bhp	Rpm	Bhp	Rpm	Bhp
1500	1000	0.68	1047	0.76	1092	0.84	1134	0.93	1174	1.01	1213	1.10	1249	1.19	1284	1.28	1318	1.36	1351	1.46
1600	1001	0.71	1049	0.80	1094	0.88	1137	0.97	1178	1.06	1218	1.14	1255	1.24	1291	1.33	1326	1.42	1359	1.52
1700	1004	0.75	1051	0.83	1096	0.92	1139	1.01	1181	1.10	1221	1.19	1259	1.28	1296	1.38	1331	1.48	1365	1.57
1800	1007	0.79	1053	0.87	1098	0.96	1141	1.05	1183	1.14	1224	1.24	1262	1.33	1300	1.43	—	—	—	—
1900	1011	0.83	1056	0.92	1100	1.00	1143	1.09	1185	1.19	1225	1.28	1264	1.38	1302	1.48	—	—	—	—
2000	1018	0.89	1061	0.97	1104	1.05	1146	1.14	1187	1.24	1227	1.33	1266	1.43	—	—	—	—	—	—
2100	1027	0.94	1068	1.02	1109	1.11	1150	1.20	1190	1.29	1230	1.39	1268	1.49	—	—	—	—	—	—
2200	1037	1.01	1076	1.09	1116	1.17	1155	1.26	1194	1.35	1233	1.45	—	—	—	—	—	—	—	—
2300	1049	1.08	1087	1.16	1124	1.24	1162	1.33	1200	1.42	—	—	—	—	—	—	—	—	—	—
2400	1063	1.16	1099	1.23	1135	1.32	1171	1.40	1207	1.49	—	—	—	—	—	—	—	—	—	—
2500	1077	1.24	1112	1.32	1147	1.40	1181	1.48	1216	1.57	—	—	—	—	—	—	—	—	—	—

LEGEND

Bhp — Brake Horsepower
ESP — External Static Pressure

NOTES:

1. Units are available with several motor hp options. Refer to Physical Data table.
2. Static pressure losses for any options or accessories must be applied to external static pressure before entering the fan performance table.
3. Interpolation is permitted; extrapolation is not.
4. Fan performance is based on 1 in. standard throwaway filter, unit casing, and dry DX (direct expansion) coil losses at sea level.

Performance data (cont)



EVAPORATOR FAN PERFORMANCE (cont)

50XCA08 (7½ Tons)																				
CFM	ESP (in. wg)																			
	0.00		0.10		0.20		0.30		0.40		0.50		0.60		0.70		0.80		0.90	
	Rpm	Bhp	Rpm	Bhp	Rpm	Bhp	Rpm	Bhp	Rpm	Bhp	Rpm	Bhp	Rpm	Bhp	Rpm	Bhp	Rpm	Bhp	Rpm	Bhp
2200	594	0.26	594	0.26	594	0.26	644	0.31	707	0.38	766	0.45	820	0.53	871	0.62	918	0.70	963	0.79
2400	588	0.28	588	0.28	602	0.29	667	0.36	728	0.43	785	0.51	838	0.59	888	0.68	935	0.77	979	0.86
2600	582	0.29	582	0.29	630	0.34	692	0.42	750	0.49	805	0.58	857	0.66	906	0.75	952	0.84	996	0.94
2800	576	0.31	597	0.33	659	0.41	718	0.48	774	0.56	827	0.65	877	0.74	925	0.83	970	0.93	1013	1.03
3000	570	0.33	631	0.40	690	0.48	746	0.55	799	0.64	850	0.73	898	0.82	945	0.92	989	1.02	1032	1.12
3200	606	0.40	665	0.48	721	0.55	774	0.64	825	0.73	874	0.82	921	0.91	966	1.01	1009	1.12	1051	1.22
3400	644	0.48	699	0.56	752	0.64	803	0.73	852	0.82	899	0.92	944	1.02	988	1.12	1030	1.23	1071	1.34
3600	681	0.57	734	0.66	785	0.74	833	0.83	880	0.93	925	1.03	969	1.13	1011	1.24	1052	1.35	1092	1.46
3800	719	0.67	770	0.76	818	0.85	864	0.95	909	1.04	952	1.15	995	1.25	1035	1.36	1075	1.48	1114	1.59

50XCA08 (7½ Tons) (cont)																				
CFM	ESP (in. wg)																			
	1.00		1.10		1.20		1.30		1.40		1.50		1.60		1.70		1.80		1.90	
	Rpm	Bhp	Rpm	Bhp	Rpm	Bhp	Rpm	Bhp	Rpm	Bhp	Rpm	Bhp	Rpm	Bhp	Rpm	Bhp	Rpm	Bhp	Rpm	Bhp
2200	1006	0.88	1047	0.97	1085	1.07	1122	1.17	1158	1.27	1193	1.37	1226	1.47	1258	1.58	—	—	—	—
2400	1022	0.96	1062	1.05	1101	1.15	1138	1.26	1174	1.36	1209	1.46	1242	1.57	1274	1.68	1306	1.79	1336	1.90
2600	1038	1.04	1078	1.14	1117	1.24	1154	1.35	1190	1.46	1225	1.57	1258	1.68	1290	1.79	1322	1.91	1352	2.03
2800	1055	1.13	1095	1.23	1133	1.34	1170	1.45	1206	1.56	1240	1.68	1274	1.79	1306	1.91	1338	2.03	1368	2.15
3000	1073	1.23	1112	1.34	1150	1.45	1187	1.56	1222	1.68	1256	1.79	1290	1.91	1322	2.04	1353	2.16	1384	2.29
3200	1091	1.33	1130	1.45	1167	1.56	1204	1.68	1239	1.80	1273	1.92	1306	2.04	1338	2.17	1369	2.30	1400	2.43
3400	1110	1.45	1148	1.57	1185	1.68	1221	1.81	1256	1.93	1290	2.05	1322	2.18	1354	2.31	1385	2.44	1416	2.58
3600	1131	1.58	1168	1.69	1204	1.82	1239	1.94	1274	2.07	1307	2.20	1340	2.33	1371	2.46	1402	2.60	1432	2.74
3800	1152	1.71	1188	1.84	1224	1.96	1258	2.09	1292	2.22	1325	2.35	1357	2.49	1389	2.62	1419	2.76	1449	2.90

50XCA08 (7½ Tons) (cont)										
CFM	ESP (in. wg)									
	2.00		2.10		2.20		2.30		2.40	
	Rpm	Bhp	Rpm	Bhp	Rpm	Bhp	Rpm	Bhp	Rpm	Bhp
2200	—	—	—	—	—	—	—	—	—	—
2400	1366	2.02	1395	2.13	—	—	—	—	—	—
2600	1382	2.14	1411	2.26	1439	2.39	1467	2.51	1494	2.63
2800	1398	2.27	1427	2.40	1455	2.52	1483	2.65	1510	2.78
3000	1414	2.41	1443	2.54	1471	2.67	1499	2.80	1526	2.94
3200	1429	2.56	1459	2.69	1487	2.82	1515	2.96	—	—
3400	1445	2.71	1474	2.85	1503	2.99	—	—	—	—
3600	1462	2.87	—	—	—	—	—	—	—	—
3800	—	—	—	—	—	—	—	—	—	—

LEGEND

Bhp — Brake Horsepower
ESP — External Static Pressure

NOTES:

- Units are available with several motor hp options. Refer to Physical Data table.
- Static pressure losses for any options or accessories must be applied to external static pressure before entering the fan performance table.

- Interpolation is permitted; extrapolation is not.
- Fan performance is based on 1 in. standard throwaway filter, unit casing, and dry DX (direct expansion) coil losses at sea level.



EVAPORATOR FAN PERFORMANCE (cont)

50XCA12 (10 Tons)																					
CFM	ESP (in. wg)																				
	0.00		0.10		0.20		0.30		0.40		0.50		0.60		0.70		0.80		0.90		
	Rpm	Bhp	Rpm	Bhp	Rpm	Bhp	Rpm	Bhp	Rpm	Bhp	Rpm	Bhp	Rpm	Bhp	Rpm	Bhp	Rpm	Bhp	Rpm	Bhp	
3000	410	0.32	475	0.41	536	0.51	592	0.62	645	0.74	696	0.86	743	0.99	789	1.12	832	1.26	874	1.40	
3200	437	0.38	498	0.48	556	0.59	610	0.70	661	0.83	710	0.95	756	1.08	800	1.22	843	1.36	884	1.51	
3400	464	0.46	522	0.57	577	0.68	629	0.80	678	0.92	725	1.05	770	1.19	813	1.33	854	1.48	894	1.63	
3600	492	0.55	547	0.66	599	0.77	649	0.90	696	1.03	741	1.17	785	1.31	827	1.45	867	1.60	906	1.76	
3800	519	0.64	571	0.76	621	0.88	669	1.01	714	1.15	758	1.29	800	1.43	841	1.59	880	1.74	918	1.90	
4000	546	0.75	596	0.87	644	1.00	689	1.14	733	1.28	776	1.42	817	1.57	856	1.73	894	1.89	932	2.05	
4200	574	0.87	621	0.99	667	1.13	711	1.27	753	1.42	794	1.57	834	1.72	872	1.88	909	2.05	946	2.22	
4400	601	1.00	646	1.13	690	1.27	732	1.42	773	1.57	813	1.72	852	1.88	889	2.05	925	2.22	960	2.39	
4600	628	1.14	672	1.28	714	1.42	755	1.58	794	1.73	833	1.89	870	2.06	906	2.23	942	2.40	976	2.58	
4800	655	1.29	697	1.44	738	1.59	777	1.75	815	1.91	853	2.08	889	2.25	924	2.42	958	2.60	992	2.78	
5000	683	1.46	723	1.61	762	1.77	800	1.93	837	2.10	873	2.27	908	2.45	943	2.63	976	2.81	1009	3.00	

50XCA12 (10 Tons) (cont)																					
CFM	ESP (in. wg)																				
	1.00		1.10		1.20		1.30		1.40		1.50		1.60		1.70		1.80		1.90		
	Rpm	Bhp	Rpm	Bhp	Rpm	Bhp	Rpm	Bhp	Rpm	Bhp	Rpm	Bhp	Rpm	Bhp	Rpm	Bhp	Rpm	Bhp	Rpm	Bhp	
3000	914	1.55	—	—	—	—	—	—	—	—	—	—	—	—	—	—	—	—	—	—	
3200	923	1.66	961	1.82	—	—	—	—	—	—	—	—	—	—	—	—	—	—	—	—	
3400	933	1.79	970	1.95	1006	2.11	—	—	—	—	—	—	—	—	—	—	—	—	—	—	
3600	943	1.92	980	2.09	1015	2.25	1050	2.43	1084	2.61	—	—	—	—	—	—	—	—	—	—	
3800	955	2.07	991	2.24	1026	2.41	1060	2.59	1093	2.77	1125	2.95	1156	3.14	—	—	—	—	—	—	
4000	968	2.22	1003	2.40	1037	2.57	1070	2.75	1102	2.94	1134	3.13	1165	3.32	1195	3.52	—	—	—	—	
4200	981	2.39	1015	2.57	1049	2.75	1081	2.94	1113	3.12	1144	3.32	1175	3.51	1205	3.71	1234	3.92	1263	4.13	
4400	995	2.57	1028	2.75	1061	2.94	1093	3.13	1124	3.32	1155	3.52	1185	3.72	1214	3.92	1243	4.13	1272	4.34	
4600	1010	2.76	1042	2.95	1074	3.14	1106	3.34	1136	3.53	1166	3.74	1196	3.94	1225	4.15	1253	4.36	1281	4.58	
4800	1025	2.97	1057	3.16	1088	3.36	1119	3.56	1149	3.76	1179	3.96	1208	4.17	1236	4.39	1264	4.60	1292	4.82	
5000	1041	3.19	1072	3.39	1103	3.59	1133	3.79	1163	4.00	1192	4.21	1220	4.42	1248	4.64	1276	4.86	1303	5.08	

LEGEND

Bhp — Brake Horsepower
ESP — External Static Pressure

NOTES:

- Units are available with several motor hp options. Refer to Physical Data table.
- Static pressure losses for any options or accessories must be applied to external static pressure before entering the fan performance table.
- Interpolation is permitted; extrapolation is not.
- Fan performance is based on 1 in. standard throwaway filter, unit casing, and dry DX (direct expansion) coil losses at sea level.

Performance data (cont)



EVAPORATOR FAN PERFORMANCE (cont)

50XCA14 (12 Tons)

CFM	ESP (in. wg)																			
	0.00		0.10		0.20		0.30		0.40		0.50		0.60		0.70		0.80		0.90	
	Rpm	Bhp	Rpm	Bhp	Rpm	Bhp	Rpm	Bhp	Rpm	Bhp	Rpm	Bhp	Rpm	Bhp	Rpm	Bhp	Rpm	Bhp	Rpm	Bhp
3500	594	0.62	594	0.62	645	0.71	694	0.80	739	0.88	782	0.97	823	1.06	862	1.15	900	1.23	936	1.32
3700	588	0.66	622	0.72	671	0.82	718	0.91	761	1.00	803	1.09	843	1.18	881	1.28	918	1.37	953	1.46
3900	600	0.74	650	0.84	697	0.93	742	1.03	784	1.13	825	1.22	863	1.32	901	1.42	937	1.52	971	1.61
4100	630	0.86	678	0.96	724	1.06	767	1.16	808	1.27	847	1.37	885	1.47	921	1.57	956	1.68	990	1.78
4300	661	0.99	707	1.10	751	1.20	792	1.31	832	1.42	870	1.53	907	1.63	942	1.74	976	1.85	1009	1.95
4500	692	1.14	736	1.25	778	1.36	818	1.47	856	1.58	893	1.69	929	1.81	963	1.92	997	2.03	1029	2.14
4700	723	1.29	765	1.41	805	1.53	844	1.64	881	1.76	917	1.88	952	1.99	985	2.11	1018	2.23	1050	2.35
4900	753	1.47	794	1.59	833	1.71	870	1.83	906	1.95	941	2.08	975	2.20	1008	2.32	1040	2.44	1071	2.56
5100	784	1.65	823	1.78	861	1.91	897	2.03	932	2.16	966	2.29	999	2.41	1031	2.54	1062	2.67	1092	2.79
5300	815	1.86	853	1.99	889	2.12	924	2.25	958	2.38	991	2.51	1023	2.65	1054	2.78	1084	2.91	1114	3.04
5500	846	2.07	882	2.21	917	2.35	951	2.48	984	2.62	1016	2.76	1047	2.89	1078	3.03	1107	3.17	1136	3.30
5700	876	2.31	911	2.45	945	2.59	978	2.73	1011	2.88	1042	3.02	1072	3.16	1102	3.30	1131	3.44	1159	3.58
5900	907	2.56	941	2.71	974	2.85	1006	3.00	1037	3.15	1068	3.29	1097	3.44	1126	3.59	1155	3.73	1182	3.88
6100	938	2.83	971	2.98	1003	3.13	1034	3.28	1064	3.44	1094	3.59	1123	3.74	1151	3.89	1179	4.04	1206	4.19

50XCA14 (12 tons) (cont)

CFM	ESP (in. wg)																			
	1.00		1.10		1.20		1.30		1.40		1.50		1.60		1.70		1.80		1.90	
	Rpm	Bhp	Rpm	Bhp	Rpm	Bhp	Rpm	Bhp	Rpm	Bhp	Rpm	Bhp	Rpm	Bhp	Rpm	Bhp	Rpm	Bhp	Rpm	Bhp
3500	971	1.41	1005	1.50	1038	1.59	—	—	—	—	—	—	—	—	—	—	—	—	—	—
3700	987	1.56	1021	1.65	1053	1.75	1084	1.84	1115	1.94	—	—	—	—	—	—	—	—	—	—
3900	1005	1.71	1037	1.81	1069	1.91	1100	2.01	1130	2.11	1159	2.21	1187	2.31	—	—	—	—	—	—
4100	1023	1.88	1055	1.98	1086	2.09	1116	2.19	1145	2.30	1174	2.40	1202	2.51	1230	2.62	—	—	—	—
4300	1041	2.06	1073	2.17	1103	2.28	1133	2.39	1162	2.50	1190	2.61	1218	2.72	1245	2.83	1272	2.94	1298	3.05
4500	1061	2.26	1091	2.37	1121	2.48	1150	2.60	1179	2.71	1207	2.82	1234	2.94	1261	3.05	1287	3.17	1313	3.29
4700	1080	2.46	1110	2.58	1140	2.70	1168	2.82	1196	2.94	1224	3.06	1251	3.17	1277	3.29	1303	3.41	1328	3.53
4900	1101	2.68	1130	2.81	1159	2.93	1187	3.05	1215	3.18	1242	3.30	1268	3.42	1294	3.55	1319	3.67	1344	3.80
5100	1122	2.92	1150	3.05	1179	3.18	1206	3.30	1233	3.43	1260	3.56	1286	3.69	1311	3.82	1336	3.95	1361	4.08
5300	1143	3.17	1171	3.30	1199	3.44	1226	3.57	1253	3.70	1279	3.84	1304	3.97	1329	4.10	1354	4.24	1378	4.37
5500	1165	3.44	1192	3.58	1220	3.71	1246	3.85	1272	3.99	1298	4.13	1323	4.26	1348	4.40	1372	4.54	1396	4.68
5700	1187	3.72	1214	3.87	1241	4.01	1267	4.15	1292	4.29	1318	4.44	1342	4.58	1367	4.72	1391	4.86	—	—
5900	1209	4.03	1236	4.17	1262	4.32	1288	4.47	1313	4.61	1338	4.76	1362	4.91	—	—	—	—	—	—
6100	1232	4.34	1258	4.50	1284	4.65	1309	4.80	1334	4.95	—	—	—	—	—	—	—	—	—	—

LEGEND

Bhp — Brake Horsepower
ESP — External Static Pressure

NOTES:

- Units are available with several motor hp options. Refer to Physical Data table.
- Static pressure losses for any options or accessories must be applied to external static pressure before entering the fan performance table.
- Interpolation is permitted; extrapolation is not.
- Fan performance is based on 1 in. standard throwaway filter, unit casing, and dry DX (direct expansion) coil losses at sea level.



EVAPORATOR FAN PERFORMANCE (cont)

50XCA16 (15 Tons)

CFM	ESP (in. wg)																			
	0.00		0.10		0.20		0.30		0.40		0.50		0.60		0.70		0.80		0.90	
	Rpm	Bhp	Rpm	Bhp	Rpm	Bhp	Rpm	Bhp	Rpm	Bhp	Rpm	Bhp	Rpm	Bhp	Rpm	Bhp	Rpm	Bhp	Rpm	Bhp
4500	594	0.50	594	0.50	603	0.51	656	0.59	706	0.67	753	0.75	798	0.82	840	0.90	880	0.98	—	—
4750	588	0.53	588	0.53	624	0.58	676	0.67	724	0.75	770	0.83	813	0.91	855	1.00	894	1.08	933	1.16
5000	582	0.56	592	0.58	646	0.66	696	0.75	743	0.83	787	0.92	830	1.01	870	1.10	909	1.18	947	1.27
5250	576	0.59	616	0.66	668	0.75	716	0.84	762	0.93	805	1.02	847	1.11	886	1.20	924	1.29	961	1.39
5500	587	0.65	641	0.75	690	0.84	737	0.94	782	1.03	824	1.13	864	1.22	903	1.32	940	1.41	976	1.51
5750	614	0.75	665	0.85	713	0.94	759	1.04	802	1.14	843	1.24	882	1.34	920	1.44	957	1.54	992	1.64
6000	641	0.85	690	0.95	736	1.05	780	1.16	822	1.26	862	1.36	901	1.47	938	1.57	974	1.67	1008	1.78
6250	667	0.96	715	1.07	760	1.17	802	1.28	843	1.39	882	1.49	920	1.60	956	1.71	991	1.82	1025	1.93
6500	694	1.08	740	1.19	783	1.30	824	1.41	864	1.52	902	1.64	939	1.75	974	1.86	1009	1.97	1042	2.08
6750	721	1.21	765	1.32	807	1.44	847	1.56	885	1.67	923	1.79	958	1.90	993	2.02	1027	2.13	1059	2.25
7000	747	1.35	790	1.47	831	1.59	870	1.71	907	1.83	943	1.95	978	2.07	1012	2.19	1045	2.31	1077	2.43
7250	774	1.50	815	1.62	855	1.75	893	1.87	929	1.99	965	2.12	999	2.24	1032	2.37	1064	2.49	1096	2.62
7500	801	1.66	841	1.79	879	1.92	916	2.04	951	2.17	986	2.30	1019	2.43	1052	2.56	1084	2.69	1114	2.82

50XCA16 (15 Tons) (cont)

CFM	ESP (in. wg)																			
	1.00		1.10		1.20		1.30		1.40		1.50		1.60		1.70		1.80		1.90	
	Rpm	Bhp	Rpm	Bhp	Rpm	Bhp	Rpm	Bhp	Rpm	Bhp	Rpm	Bhp	Rpm	Bhp	Rpm	Bhp	Rpm	Bhp	Rpm	Bhp
4500	—	—	—	—	—	—	—	—	—	—	—	—	—	—	—	—	—	—	—	—
4750	—	—	—	—	—	—	—	—	—	—	—	—	—	—	—	—	—	—	—	—
5000	983	1.36	—	—	—	—	—	—	—	—	—	—	—	—	—	—	—	—	—	—
5250	997	1.48	1031	1.57	1064	1.67	—	—	—	—	—	—	—	—	—	—	—	—	—	—
5500	1011	1.61	1045	1.70	1078	1.80	1109	1.90	—	—	—	—	—	—	—	—	—	—	—	—
5750	1026	1.74	1059	1.84	1092	1.94	1123	2.05	1154	2.15	—	—	—	—	—	—	—	—	—	—
6000	1042	1.88	1074	1.99	1106	2.10	1137	2.20	1167	2.31	1197	2.42	1226	2.53	—	—	—	—	—	—
6250	1058	2.04	1090	2.15	1121	2.26	1152	2.37	1181	2.48	1210	2.59	1239	2.70	1267	2.81	—	—	—	—
6500	1074	2.20	1106	2.31	1136	2.43	1167	2.54	1196	2.65	1225	2.77	1253	2.89	1280	3.00	1307	3.12	—	—
6750	1091	2.37	1122	2.49	1152	2.60	1182	2.72	1211	2.84	1239	2.96	1267	3.08	1294	3.20	1321	3.32	1347	3.44
7000	1109	2.55	1139	2.67	1169	2.79	1198	2.92	1226	3.04	1254	3.16	1281	3.29	1308	3.41	1335	3.54	1360	3.66
7250	1126	2.74	1156	2.87	1186	2.99	1214	3.12	1242	3.25	1270	3.37	1297	3.50	1323	3.63	1349	3.76	1374	3.89
7500	1145	2.94	1174	3.07	1203	3.20	1231	3.33	1258	3.47	1286	3.60	1312	3.73	1338	3.86	1364	3.99	1389	4.13

LEGEND

Bhp — Brake Horsepower
ESP — External Static Pressure

NOTES:

- Units are available with several motor hp options. Refer to Physical Data table.
- Static pressure losses for any options or accessories must be applied to external static pressure before entering the fan performance table.

- Interpolation is permitted; extrapolation is not.
- Fan performance is based on 1 in. standard throwaway filter, unit casing, and dry DX (direct expansion) coil losses at sea level.

Performance data (cont)



EVAPORATOR FAN PERFORMANCE (cont)

50XCA24 (20 Tons)																				
CFM	ESP (in. wg)																			
	0.00		0.10		0.20		0.30		0.40		0.50		0.60		0.70		0.80		0.90	
	Rpm	Bhp	Rpm	Bhp	Rpm	Bhp	Rpm	Bhp	Rpm	Bhp	Rpm	Bhp	Rpm	Bhp	Rpm	Bhp	Rpm	Bhp	Rpm	Bhp
6,000	594	1.01	594	1.01	645	1.17	693	1.34	737	1.52	781	1.70	825	1.90	870	2.12	917	2.36	965	2.62
6,300	588	1.07	612	1.14	667	1.32	714	1.50	757	1.68	799	1.87	840	2.07	883	2.28	926	2.52	971	2.77
6,600	588	1.14	636	1.29	689	1.48	735	1.67	777	1.86	817	2.05	857	2.25	897	2.47	938	2.70	979	2.95
6,900	615	1.30	660	1.45	711	1.65	757	1.85	798	2.05	837	2.25	875	2.45	913	2.67	951	2.90	990	3.15
7,200	642	1.48	684	1.63	734	1.84	779	2.05	819	2.25	857	2.46	894	2.67	930	2.89	966	3.13	1003	3.37
7,500	668	1.68	708	1.83	756	2.04	801	2.26	840	2.47	877	2.69	913	2.91	948	3.13	983	3.37	1018	3.61
7,800	695	1.88	733	2.04	779	2.26	823	2.49	862	2.71	898	2.93	933	3.16	967	3.39	1000	3.63	1034	3.87
8,000	713	2.03	750	2.19	795	2.41	838	2.65	876	2.88	912	3.10	946	3.33	979	3.57	1012	3.81	1045	4.06
8,300	740	2.27	774	2.43	818	2.66	860	2.90	898	3.14	934	3.38	967	3.61	999	3.85	1031	4.10	1062	4.35
8,600	766	2.53	800	2.69	841	2.92	882	3.17	920	3.42	955	3.67	988	3.91	1019	4.16	1050	4.41	1081	4.67
8,900	793	2.80	825	2.97	865	3.20	905	3.46	942	3.72	977	3.97	1009	4.23	1040	4.48	1070	4.74	1100	5.00
9,200	820	3.09	850	3.27	888	3.50	928	3.77	964	4.04	998	4.30	1030	4.56	1061	4.82	1090	5.09	1119	5.36
9,500	846	3.40	876	3.58	912	3.82	950	4.09	987	4.37	1020	4.64	1052	4.92	1082	5.19	1111	5.46	1139	5.73
9,800	873	3.74	901	3.92	936	4.16	973	4.44	1009	4.72	1042	5.01	1074	5.29	1103	5.57	1131	5.85	1159	6.13
10,000	891	3.97	918	4.16	952	4.40	989	4.68	1024	4.97	1057	5.26	1088	5.55	1117	5.83	1145	6.12	1173	6.40

50XCA24 (20 Tons) (cont)																				
CFM	ESP (in. wg)																			
	1.00		1.10		1.20		1.30		1.40		1.50		1.60		1.70		1.80		1.90	
	Rpm	Bhp	Rpm	Bhp	Rpm	Bhp	Rpm	Bhp	Rpm	Bhp	Rpm	Bhp	Rpm	Bhp	Rpm	Bhp	Rpm	Bhp	Rpm	Bhp
6,000	1014	2.90	1063	3.20	1112	3.53	1161	3.87	1208	4.23	—	—	—	—	—	—	—	—	—	—
6,300	1016	3.05	1063	3.35	1110	3.66	1157	4.00	1204	4.36	1249	4.73	—	—	—	—	—	—	—	—
6,600	1022	3.22	1066	3.51	1111	3.83	1155	4.16	1200	4.50	1245	4.87	1289	5.25	1332	5.65	—	—	—	—
6,900	1030	3.42	1072	3.70	1113	4.01	1156	4.33	1199	4.67	1242	5.03	1285	5.41	1327	5.80	1369	6.21	1409	6.63
7,200	1041	3.64	1080	3.92	1119	4.22	1159	4.53	1200	4.87	1241	5.22	1282	5.59	1323	5.98	1364	6.38	1404	6.80
7,500	1053	3.88	1090	4.15	1127	4.45	1165	4.76	1203	5.09	1242	5.43	1282	5.80	1321	6.18	1361	6.58	1400	6.99
7,800	1068	4.14	1102	4.41	1137	4.70	1173	5.01	1209	5.33	1246	5.67	1284	6.03	1321	6.40	1360	6.80	1397	7.20
8,000	1078	4.32	1111	4.60	1145	4.88	1179	5.19	1214	5.51	1250	5.85	1286	6.20	1323	6.57	1360	6.96	1397	7.36
8,300	1094	4.62	1126	4.89	1158	5.18	1191	5.48	1224	5.80	1258	6.13	1292	6.48	1327	6.84	1362	7.22	1397	7.62
8,600	1111	4.93	1141	5.21	1172	5.50	1203	5.80	1235	6.11	1267	6.44	1300	6.78	1333	7.14	1366	7.51	1400	7.90
8,900	1129	5.27	1158	5.55	1188	5.84	1218	6.14	1248	6.45	1278	6.77	1309	7.11	1341	7.47	1372	7.83	1405	8.22
9,200	1147	5.63	1176	5.91	1204	6.20	1233	6.50	1262	6.81	1291	7.14	1320	7.47	1350	7.82	1381	8.19	1411	8.56
9,500	1167	6.01	1194	6.30	1222	6.59	1249	6.89	1277	7.20	1305	7.53	1333	7.86	1362	8.21	1391	8.57	1420	8.94
9,800	1186	6.41	1213	6.70	1240	7.00	1266	7.30	1293	7.62	1320	7.94	1347	8.28	1374	8.62	1402	8.98	1430	9.35
10,000	1200	6.69	1226	6.99	1252	7.29	1278	7.59	1304	7.91	1331	8.23	1357	8.57	1384	8.91	1411	9.27	1438	9.63

LEGEND

Bhp — Brake Horsepower
ESP — External Static Pressure

NOTES:

- Units are available with several motor hp options. Refer to Physical Data table.
- Static pressure losses for any options or accessories must be applied to external static pressure before entering the fan performance table.
- Interpolation is permitted; extrapolation is not.
- Fan performance is based on 1 in. standard throwaway filter, unit casing, and dry DX (direct expansion) coil losses at sea level.

Electrical data



UNIT ELECTRICAL DATA

UNIT 50XCA	V-PH-Hz	VOLTAGE RANGE		COMPRESSOR NO. 1		COMPRESSOR NO. 2	
		Min	Max	RLA	LRA	RLA	LRA
06	208/230-3-60	187	253	20.5	155	—	—
	460-3-60	414	506	9.6	75	—	—
	575-3-60	518	632	7.6	54	—	—
08	208/230-3-60	187	253	22.4	149	—	—
	460-3-60	414	506	10.6	75	—	—
	575-3-60	518	632	7.7	54	—	—
12	208/230-3-60	187	253	16.0	110	16.0	110
	460-3-60	414	506	7.8	52	7.8	52
	575-3-60	518	632	5.7	39	5.7	39
14	208/230-3-60	187	253	20.5	155	20.5	155
	460-3-60	414	506	9.6	75	9.6	75
	575-3-60	518	632	7.6	54	7.6	54
16	208/230-3-60	187	253	23.2	164	23.2	164
	460-3-60	414	506	11.2	75	11.2	75
	575-3-60	518	632	7.9	54	7.9	54
24	208/230-3-60	187	253	30.1	225	30.1	225
	460-3-60	414	506	16.7	114	16.7	114
	575-3-60	518	632	12.2	80	12.2	80

LEGEND

- FLA — Full Load Amps
- LRA — Locked Rotor Amps
- NEC — National Electrical Code
- RLA — Rated Load Amps



NOTES:

1. In compliance with NEC requirements for multimotor and combination load equipment (NEC Articles 430 and 440), the overcurrent protective device for the unit shall be fuse or HACR circuit breaker. Canadian units may be fuse or circuit breaker.
2. Wire sizing amps are a sum of 125% of the compressor RLA plus 100% of indoor fan motor FLA.
3. Motors are protected against primary single phasing condition.
4. Indoor-fan motors are 3-phase motors of same voltage as unit.

Electrical data (cont)



FAN ELECTRICAL DATA

MOTOR CODE	HP	V-PH-Hz	VOLTAGE RANGE		FLA
			Min	Max	
B	0.50	208/230-3-60	187	253	1.8/2.2
		460-3-60	414	506	1.1
		575-3-60	518	632	0.9
C	0.75	208/230-3-60	187	253	2.5/2.6
		460-3-60	414	506	1.3
		575-3-60	518	632	1.0
D	1.00	208/230-3-60	187	253	3.2/3.2
		460-3-60	414	506	1.6
		575-3-60	518	632	1.1
E	1.50	208/230-3-60	187	253	4.6/4.8
		460-3-60	414	506	2.4
		575-3-60	518	632	1.6
F	2.00	208/230-3-60	187	253	6.0/5.8
		460-3-60	414	506	2.9
		575-3-60	518	632	2.1
G	3.00	208/230-3-60	187	253	9.2/8.6
		460-3-60	414	506	4.3
		575-3-60	518	632	3.4
H	5.00	208/230-3-60	187	253	14.5/13.6
		460-3-60	414	506	6.8
		575-3-60	518	632	5.4
J	7.50	208/230-3-60	187	253	21.5/19.4
		460-3-60	414	506	9.7
		575-3-60	518	632	7.5

LEGEND

FLA — Full Load Amps

NOTE: The FLA data listed in this table is for one fan only. When calculating system FLA, evaporator fan and condenser fan must be included.



Typical wiring schematics

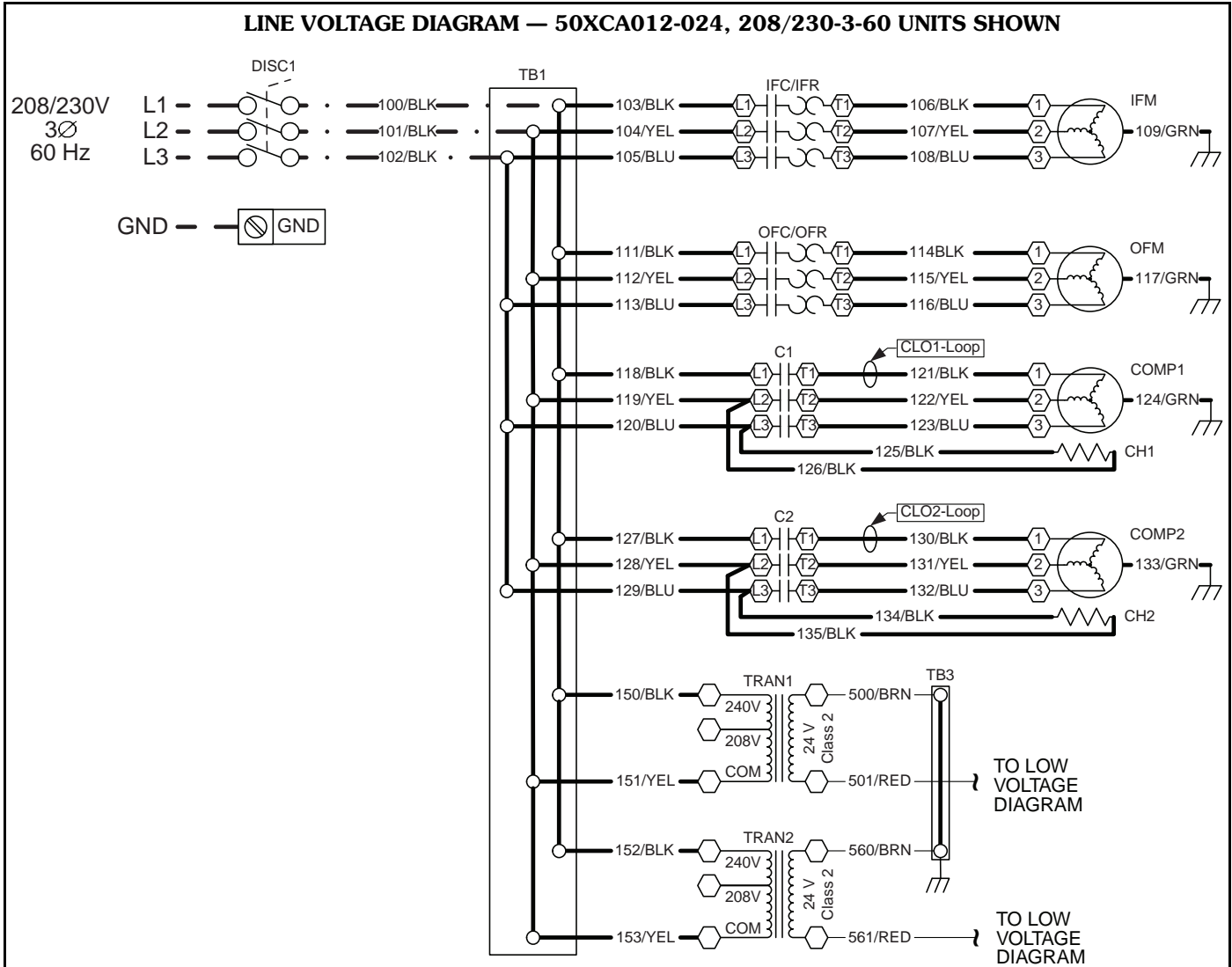

LEGEND AND NOTES FOR WIRING SCHEMATICS

LEGEND	
C	— Compressor Contactor
CH	— Crankcase Heater
CLO	— Compressor Lockout
COMP	— Compressor
CR	— Control Relay
DISC	— Disconnect
FRZ	— Freeze Protection
GND	— Ground
HPS	— High Pressure Switch
HR	— Heat Relay
IFC	— Indoor-Fan Contactor
IFM	— Indoor-Fan Motor
IFR	— Indoor-Fan Relay
LPS	— Low Pressure Switch
OFC	— Outdoor-Fan Contactor
OFM	— Outdoor-Fan Motor

OFR	— Outdoor-Fan Relay
PRES	— Pressure Transducer
TB	— Terminal Block
TRAN	— Transformer
VFD	— Variable Frequency Drive
	Terminal Block Connection
	Marked Terminal
	Unmarked Terminal
	Splice
	Factory Wiring
	Field Power Wiring

NOTES:

1. Fan motors are inherently thermally protected.
2. Three-phase motors are protected under primary single phase conditions.
3. Use conductors suitable for at least 194 F (90 C) when replacing factory wiring.
4. Use copper conductors only.
5. Wiring for field power supply must be rated at 165 F (75 C) minimum.

Typical wiring schematics (cont)



LOW VOLTAGE DIAGRAM — 50XCA012-024, 208/230-3-60 UNITS SHOWN

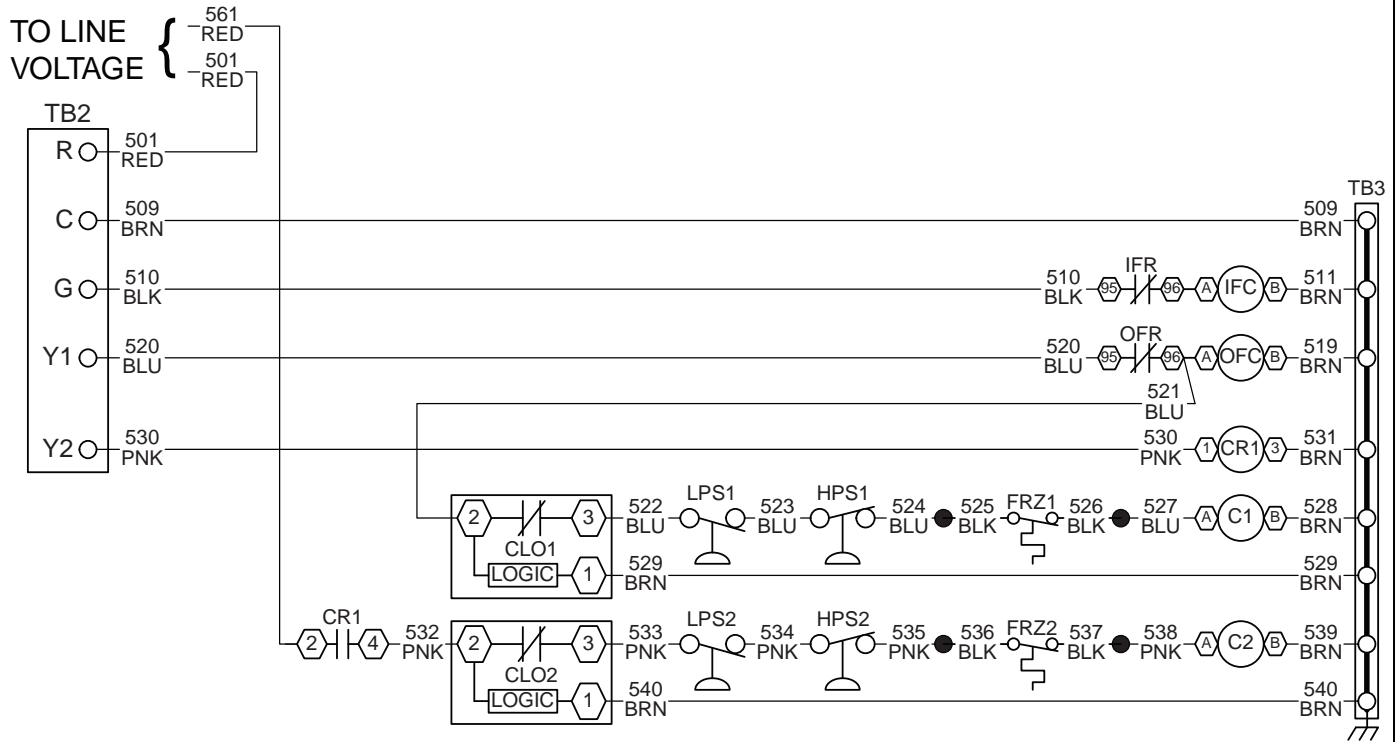

NOTE: Refer to legend and notes on page 33.

TYPICAL WIRING SCHEMATIC FOR WINTER START KIT (50XCA06,08 UNITS)

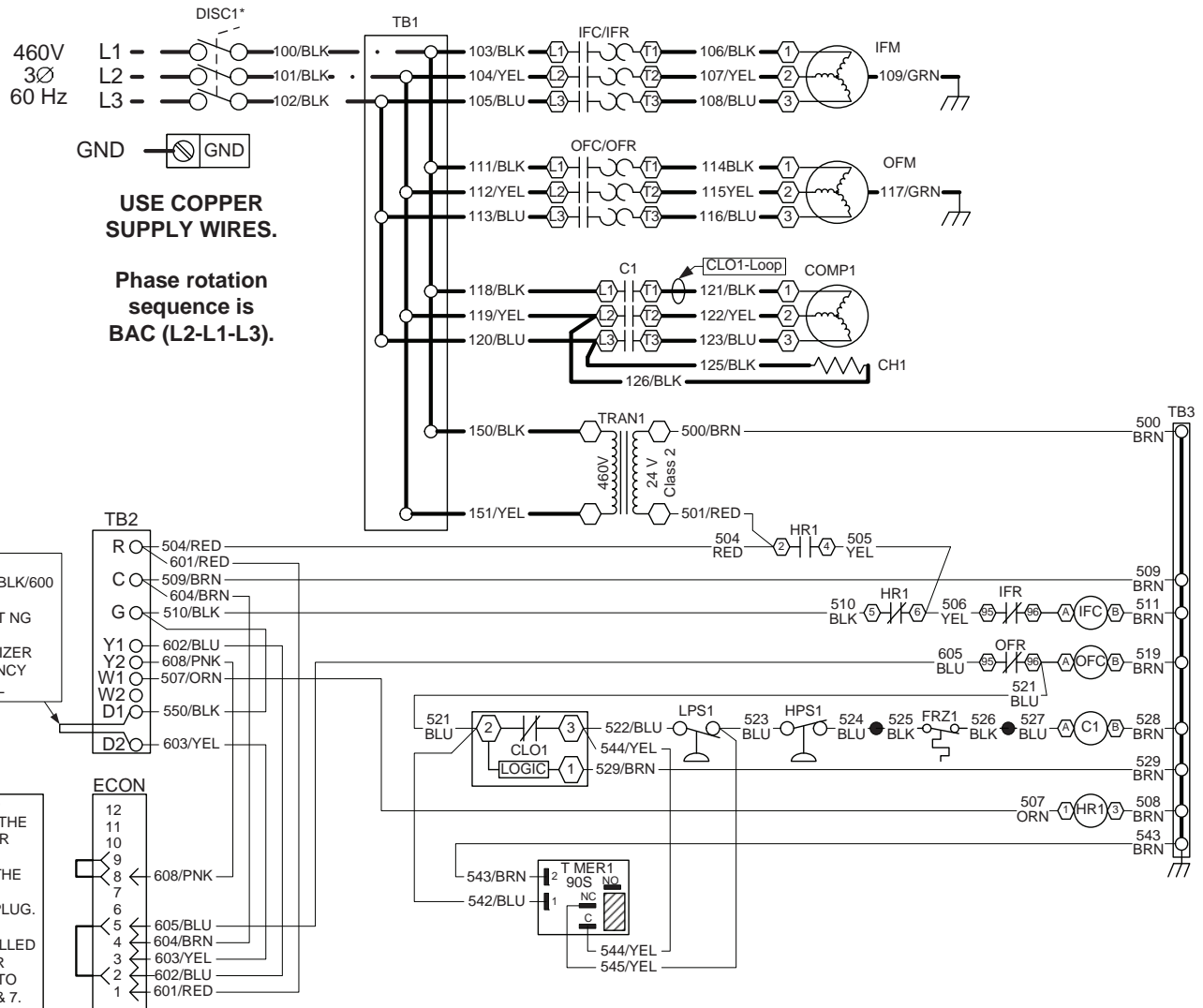

USE COPPER SUPPLY WIRES.

Phase rotation sequence is BAC (L2-L1-L3).

REMOVE JUMPER BLK/600 WHEN CONNECT NG A R-SIDE ECONOMIZER OCCUPANCY CONTROL

WHEN F EL D NSTALLED, THE ECONOMIZER HARNESS REPLACES THE FACTORY SHORTING PLUG. FIELD INSTALLED SAT SENSOR CONNECTS TO CIRCUITS 6 & 7.

NOTE: Refer to legend and notes on page 33.

Typical wiring schematics (cont)



TYPICAL WIRING SCHEMATIC FOR WINTER START KIT (50XCA12-24 UNITS)

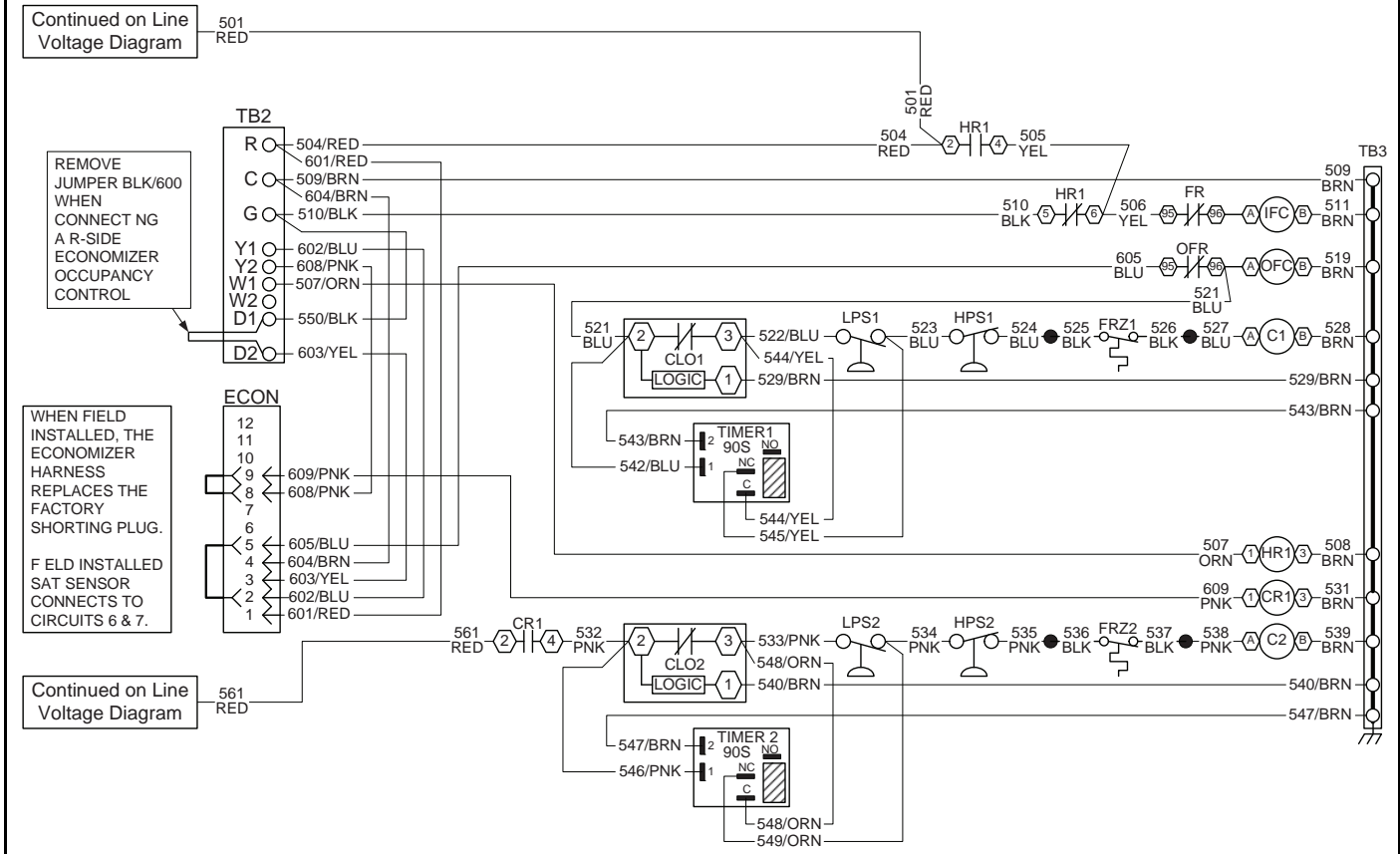

NOTE: Refer to legend and notes on page 33.

TYPICAL WIRING SCHEMATIC FOR LOW AMBIENT OPTION (50XCA06,08 UNITS)

LINE VOLTAGE
SEE UNIT NAMEPLATE
3Ø
60 Hz

**USE COPPER
SUPPLY WIRES.**

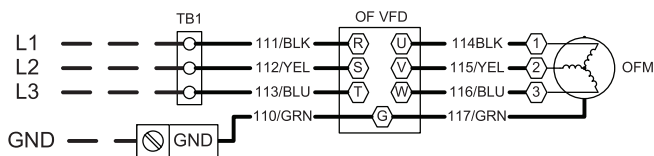

WITHOUT FACTORY INSTALLED DISCONNECT SWITCH

LINE VOLTAGE
SEE UNIT NAMEPLATE
3Ø
60 Hz

**USE COPPER
SUPPLY WIRES.**

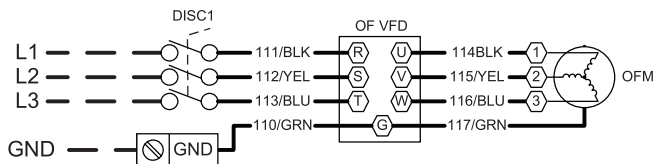

FACTORY INSTALLED DISCONNECT SWITCH OPTION



LOW VOLTAGE CONTROLS

NOTE: Refer to legend and notes on page 33.

Typical wiring schematics (cont)



TYPICAL WIRING SCHEMATIC FOR LOW AMBIENT OPTION (50XCA12-24 UNITS)

LINE VOLTAGE
SEE UNIT NAMEPLATE
3Ø
60 Hz

USE COPPER
SUPPLY WIRES.

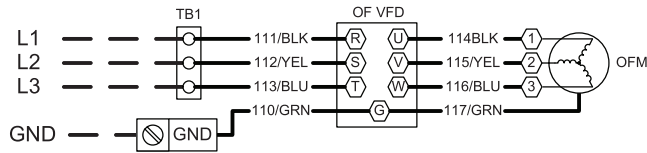

WITHOUT FACTORY INSTALLED DISCONNECT SWITCH

LINE VOLTAGE
SEE UNIT NAMEPLATE
3Ø
60 Hz

USE COPPER
SUPPLY WIRES.

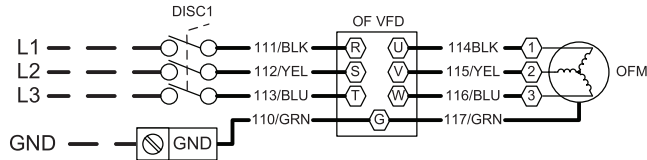

FACTORY INSTALLED DISCONNECT SWITCH OPTION

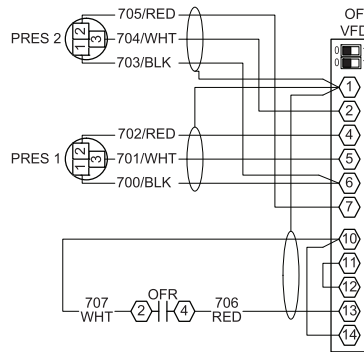

Note: PRES1, PRES2, and OFR are connected with shielded wire. The drain wire is connected to OF VFD terminal 1. The remote end of the drain wire shall be insulated.

LOW VOLTAGE CONTROLS

NOTE: Refer to legend and notes on page 33.

Controls



Operating sequence

All units require the addition of a thermostat accessory package to complete the control circuit. The sequence of operation may vary depending on which package is selected.

Room-mounted thermostat — The unit uses an electronic thermostat mounted in the conditioned space.

Fan circulation — When the thermostat selector switch is set to the FAN position, the evaporator-fan motor will operate to provide air circulation.

Cooling — The evaporator will operate continuously or when the compressor runs, depending on the setting of the thermostat fan selector switch. When the thermostat closes (on a call for cooling), the control relay condenser-fan contactor and compressor contactor(s) close. The control relay will start the indoor fan if it is not already running. The condenser fan contactor will start the condenser air fan and the compressor contactors will immediately start the compressor(s).

A second stage on 50XCA12 to 24 units will close if additional cooling demand is required, and will start the second-stage compressor. When the thermostat is satisfied, the second-stage compressor will stop first, and then the first-stage compressors will stop when cooling demand is satisfied. The condenser will also stop as soon as both cooling stages are satisfied.

A 5-minute timer, TDR (time-delay relay), will prevent the compressor(s) from restarting for 5 minutes after any compressor has stopped.

All units — The control circuit incorporates a current sensing lockout relay (Cycle-LOC™ device) that locks off the compressor(s) when any safety device is activated (low or high pressure switches, or compressor internal overload). If any compressor safety device opens, the compressor will stop. High and low-pressure switches and compressor motor overload protectors will reset automatically when the condition which caused the device to trip has dropped below the reset condition. To reset the Cycle-LOC control device, manually turn the control power OFF, then back ON.

Typical piping and wiring

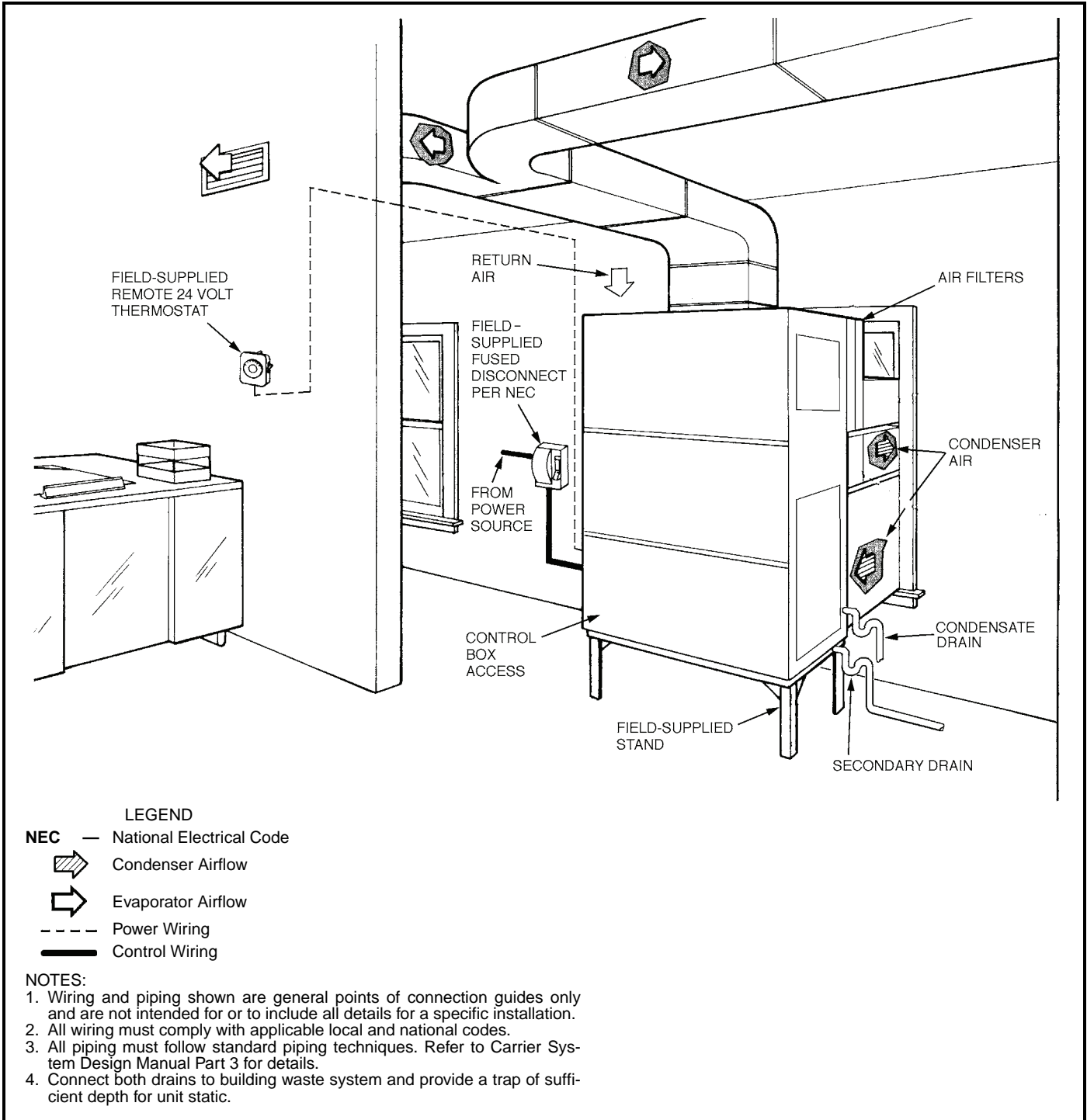

Application data



Location

For best results unit must be properly located and installed. Selected location should not be adjacent to an acoustically sensitive space, for example a conference room or executive office. The best location is in mechanical rooms near areas like elevators, restrooms, stairways, or similar spaces. The mechanical room should use construction methods which will help isolate the transmission of acoustical energy.

Since these units typically use large quantities of ducted condenser air, select a location with the best access to an outside window or wall to accommodate condenser air louver. Locate the unit as close to the wall opening as possible but allow space for return air inlet and access to the evaporator and condenser coil for cleaning. Units on the same floor should have a minimum of 6 ft between units to prevent recirculation of condenser air. Units floor to floor should have a minimum of 10 ft between units to prevent recirculation. Units should not be located with several units pulling condenser air from a small space between buildings, where air may be recirculated. Recirculation of condenser air will result in increased head pressure which may cause units to trip on high pressure.

There are several methods for applying 50XCA units in different space applications. See page 42 for recommended equipment room applications and locations of key components.

Moving units into existing buildings

The 50XCA06-14 units are designed to pass through most 36-in. door openings. The filter rack may also be removed.

Unit isolation

Unit compressors are internally isolated and the compressor compartment is lined with acoustical insulation. If additional vibration isolation is desired, rubber in-shear pads are recommended under the four corners of the unit. Spring isolation is not recommended. All duct connections to the unit should be made with flexible connections to prevent any transmission of vibration to the ductwork.

Evaporator ductwork

Supply duct should be properly supported and the aspect ratio as close to square as possible. Duct should be sized for a maximum of 2000 fpm velocity in areas outside the equipment room. The duct should be lined with acoustical insulation for a minimum of 10 ft beyond the equipment room. A flexible duct connection should be used on the connection to the unit to prevent transmission of any unit vibrations into the duct.

Return duct may be attached to the unit, but is not necessary. The return to the unit should prevent line of sight visibility to the space. Insulated return duct is also recommended for acoustically sensitive spaces. Maximum velocity should not exceed 1000 fpm over occupied spaces. Adequate return area is essential for proper operation.

Condenser ductwork

Condenser supply and discharge air ducts should be as short and straight as possible. Cross-sectional area of the inlet and discharge should never be less than the face area

of the unit openings. When bends must be made, they should be as gradual as space limitations will allow. If the unit will be operated in cold outdoor weather, or if dampers are not provided at the louver, then the condenser ducts should be insulated to prevent condensation.

Design of the louver used for the inlet and discharge of the condenser airflow is critical to preventing recirculation of air and high pressure tips. The louver blades must be heavy enough to prevent unit airflow from drawing them together. Louver blades should be a minimum of 18 gage, and widths over 30 in. should have stiffeners. The inlet louver should not have a flange and the discharge louver should have a flange which directs the air away from the inlet. The use of a deflector in conjunction with the condenser air discharge is also recommended.

Piping traps

All 50XCA units have a drain for the condensate from the evaporator coil. The condensate trap should have a depth adequate to allow 2 in. of water in the trap with the unit running. Provide a clean-out on the trap and vent and pitch the trap for proper drainage.

Controls

All units require a room mounted 24-v thermostat to complete the control system. Carrier has several versions of thermostats to meet a wide range of job conditions, including fully programmable and light-activated versions.

Operational limits

Airflow — 300 to 500 cfm per ton

Air temperature to evaporator:

Cooling

Maximum 90 F

Minimum 67 F

Condenser

Nominal airflow 350 cfm per ton,

Range: 300 to 500 cfm per ton

Condenser air temperature

Maximum 115 F

Minimum without low ambient 55 F

Minimum with low ambient 0° F

Sound considerations

All units are acoustically insulated. When installed in or near areas requiring additional sound attenuation:

- Locate unit in equipment room or closet
- Use acoustic lining in ductwork
- Provide square duct elbows with acoustic lining and turning vanes
- Locate the first supply outlet no less than 10 ft from a lined elbow.
- If unit is located in the conditioned space, return air opening from the space should be a lined elbow or equivalent.
- For critical applications, use packaged sound attenuators or duct silencers. Sound attenuation may be used on both evaporator air and condenser air.

Application data (cont)



Setting condenser fan speed

The 50XCA condenser has a centrifugal blower and a variable pitch drive which allow adjusting the condenser airflow to match the static from the louvers, ductwork,

filters, and sound traps (if used). It is best to adjust the fan to the nominal airflow and the rpm which will achieve this performance. Excess airflow and rpm will make units noisier.

TYPICAL UNIT LOCATION

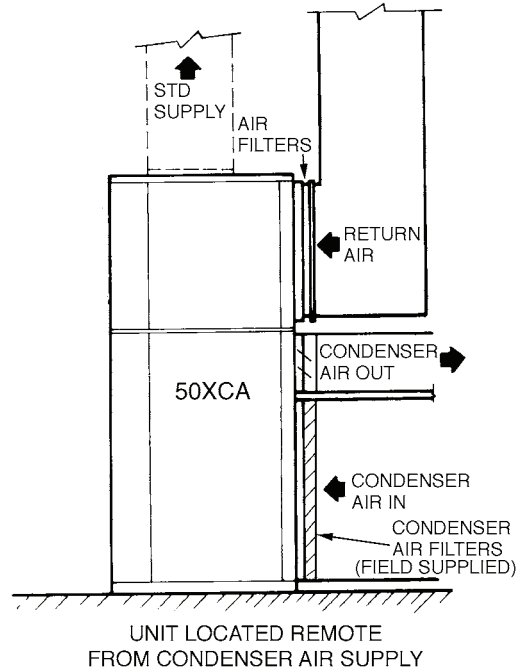
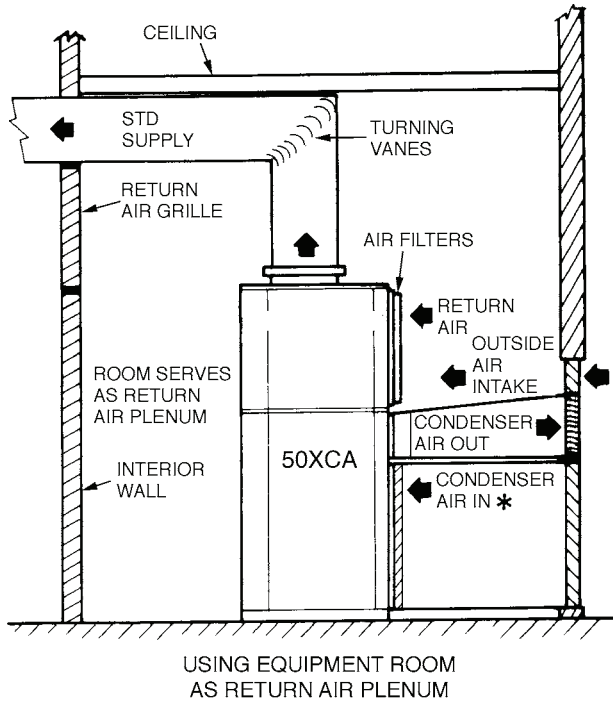

*Provide access to clean condenser coil.

NOTE: Refer to Installation Instructions for detailed louver information.

Guide specifications



Indoor Self-Contained Air-Cooled Unit Constant Volume Application

HVAC Guide Specifications

Size Range: **5 to 20 Tons**

Carrier Model Number: **50XCA**

Part 1 — General

1.01 SYSTEM DESCRIPTION

Indoor packaged vertical air-cooled cooling unit using hermetic scroll compressors and built-in condenser fan for cooling duty. Unit shall discharge supply air vertically or horizontally and condenser air horizontally as shown on contract drawings.

1.02 QUALITY ASSURANCE

- A. Units shall be rated in accordance with AHRI Standard 340/360, latest edition, as appropriate.
- B. Unit shall be designed to conform to ANSI/ASHRAE 15, latest revision safety code, and UL Standard 1995, and shall be UL listed under both American and Canadian Standards.
- C. Unit shall be built in an ISO 9001:2000 certified manufacturing facility and shall be fully run-tested.
- D. Insulation, adhesive, and liner system shall meet NFPA 90A requirements for flame spread and smoke generation.

1.03 DELIVERY, STORAGE, AND HANDLING

Units shall be stored and handled according to manufacturer's recommendations.

Part 2 — Products

2.01 EQUIPMENT

A. General:

Factory-assembled, single-piece, air-cooled cooling unit. Unit shall consist of scroll refrigerant compressor(s), indoor fan section with belt drive centrifugal fans and motor, evaporator coil section with direct expansion coil and drain pan, air-cooled condenser fan section with belt drive centrifugal fans and motor, factory wiring, piping and controls, and a system charge of refrigerant (R-410A). Unit may be used with or without return ductwork.

B. Unit Cabinet:

1. Cabinet shall be constructed of minimum 18 gage zinc surface alloyed steel with a baked enamel finish. Unit shall be capable of withstanding ASTM B117 500-hour salt spray test.
2. Cabinet shall be fully insulated.
3. Unit drain pan shall have positive double slope to the drain to prevent standing water in pan.
4. Panels for servicing shall be easily removable.

C. Evaporator Fan Section:

1. Fans shall be double inlet, centrifugal wheel with forward curved blades designed for continuous operation. Fan wheel and scroll shall be constructed of steel with corrosion resistant finish, and statically and dynamically balanced.

2. Fan shall be belt drive with an adjustable pitch motor pulley and fixed pitch fan pulley, with permanently lubricated ball-bearing type bearings. Units larger than 12 tons use pillow block bearings.
3. Motor shall be 3-phase high-efficiency NEMA frame TEFC (totally enclosed fan cooled) of the same voltage as the compressor(s). Motor shall have permanently lubricated ball bearings.

D. Compressor:

Hermetic scroll compressors shall be internally protected with high pressure relief. Compressors shall be factory rubber shock mounted with internal spring vibration isolators.

E. Coils:

1. Evaporator and condenser coil shall have aluminum plate fins mechanically bonded to seamless copper tubes with all joints brazed. Tube sheet openings shall be swaged to prevent tube wear. Coils shall be face split design.
2. Direct expansion coil shall be designed and tested in accordance with ANSI/ASHRAE 15, latest revision safety code.
3. Coil and drain pan shall be accessible through service access panels for cleaning.

F. Filter:

Filter frame shall be installed upstream of the cooling coil, designed to take a 1-in. or 2-in. thick cleanable or disposable type commercially available filter. Filters shall be accessible from either side of the unit and filter rack shall be usable with ducted or free return. Disposable filters will be supplied with the unit.

G. Condenser:

1. Fans shall be double inlet, centrifugal wheel with forward curved blades designed for continuous operation. Fan wheel and scroll shall be constructed of steel with corrosion resistant finish, and statically and dynamically balanced.
2. Fan shall be belt drive with an adjustable pitch motor pulley and fixed pitch fan pulley, with permanently lubricated, ball-bearing type bearings. Units larger than 12 tons use pillow block bearings.
3. Motor shall be 3-phase high-efficiency NEMA frame TEFC (totally enclosed fan cooled) of the same voltage as the compressor(s). Motor shall have permanently lubricated ball bearings.

H. Operating Characteristics:

Unit shall be capable of providing a constant volume of conditioned air at a specified static pressure within the unit's normal operating range. Unit shall have dual-stage cooling capacity control on all units sizes 12 to 24. Each compressor shall be on an independent refrigerant circuit. Unit shall be capable of starting and operating at up to 115 F outdoor ambient.

Guide specifications (cont)



Units shall be able to operate down to 0° F when equipped with low ambient option.

I. Controls and Safeties:

1. Units shall be furnished with a control terminal block for connection of low voltage controls and thermostats.
2. Unit shall require a room-mounted thermostat mounted in the conditioned space. Thermostat shall be digital type. Thermostat shall control fan operation and be capable of turning unit on and off.
3. Units shall have the following factory-installed safeties:
 - a. High and low-pressure switches.
 - b. Motor and compressor overtemperature.
 - c. Current lockout.
 - d. Inherent automatic fan motor overload.

J. Electrical Requirements:

All electrical power wiring shall enter the unit cabinet at a single location. Control circuit is 24-v, suitable for a field-supplied 24-v thermostat.

K. Refrigerant Components:

Refrigerant circuit components include thermal expansion valves, distributor with nozzle, filter driers, and charging service valves on each circuit. Suction line shall have a refrigerant loop to prevent refrigerant drain back to the compressor. Suction piping shall be insulated with closed cell piping insulation.

L. Special Features:

1. Air Discharge Plenum:

Plenum shall be provided to permit free-blow horizontal air distribution with movable vanes to adjust airflow in horizontal and vertical direction. Plenum is field installed and shall be fully insulated.

2. Heating Coil:

Field-installed hot water coil shall be two rows with copper tube aluminum fins and a powder coated steel casing. Fins shall be bonded to tubes by mechanical expansion. Coil to be leak tested at 400 psi air pressure submerged in water and charged with dry air.

3. Thermostats:

A complete line of thermostats shall be available to meet any application control requirements.

