

**FY5B**  
**Base Series Fan Coil**  
**Upflow / Downflow**  
**Sizes 1 1/2 – 5 Ton (018 thru 060)**



## Product Data



### **AIR HANDLER TECHNOLOGY AT ITS FINEST**

The FY5B fan coil is designed to cover a wide range of air handling requirements. This unit is specifically designed for upflow/downflow applications with the flexibility to choose between Puron® refrigerant, R-410A and R-22. The unique cabinet design of this fan coil meets new stringent regulations for cabinet air leakage, a requirement of 2% cabinet leakage rate when tested at 1.0 inches of static pressure.

The FY5B unit is shipped with a factory-installed Teflon-ring piston (018 thru 048) sizes and a Puron refrigerant TXV (060). All units come with solid state fan controls, 1-in. (25mm) thick insulation with R-value of 4.2, super-quiet multi-speed motors, and fully-wettable coils. Units can accommodate factory- or field-installed heaters from 3 to 30 kW.

The FY5B design is a residential new construction (RNC) model available for use with Puron refrigerant. It comes with or without factory-installed disconnects. It has a pre-painted (gray) galvanized insulated steel casing and fixed speed (PSC) motors for consistent airflow. ArmorCoat™ provides a tin plating of the indoor coil's copper hairpins. This creates a barrier between the corrosion-causing elements and the coil.

A10084

## STANDARD FEATURES

- Grooved copper tubing
- Lanced sine-wave aluminum fin
- Fully-wettable coil
- High-impact thermoplastic condensate pan
- Primary and secondary drain connections
- Unique cabinet design that meets regulations for air leakage. Meets requirements of a 2% cabinet leakage rate when tested at 1.0 inches of static pressure.
- Field-installed heater packages from 3-30 kW (fused, circuit breaker, or non-fused)
- Control board with built-in, replaceable 5-amp blade-type auto fuse
- 2-speed motor in 018 through 048 sizes
- 3-speed motor in 060 sizes
- Cooling controls
- Time-delay relay (TDR)
- Pre-painted galvanized steel cabinet (gray)
- High-density, super thick R-4.2 insulation
- Newly-improved filter rack area - filter door insulation added for an improved air seal
- Sweat connections
- Inspection plate for cleaning A-coil design
- 40-VA, 208/230v transformer
- All models listed with UL (U.S. and Canada) and AHRI
- Designed for manufactured housing applications

## ADDITIONAL FEATURES

- Puron® refrigerant factory-installed Teflon-ring pistons and thermostatic expansion valves (TXV)
- Factory-installed heaters available
- ArmorCoat™ coil protection available

# CARRIER FAN COIL MODEL NUMBER NOMENCLATURE

	1	2	3	4	5	6	7	8	9	10	11	12
	F	Y	5	B	N	F	0	3	6	0	0	0
<b>Product</b> Fan Coil												
<b>Type</b> E = Infinity, Variable speed, Puron V = Performance, Variable speed, Puron X = Comfort, Puron B = Base, Puron – Piston Y = Base, Puron – Piston F = Through-the-wall H = Electric Furnace												
<b>Position</b> 1 = Upflow 4 = Multipoise 5 = Upflow/downflow												
<b>Series</b> A, B, C, D, E												
<b>Electrical</b> N – 208/230v, 1 ph, 60 Hz S = 230v, 1 ph, 50 Hz												
<b>Cabinet Style</b> B – Modular Cabinet (2 piece) F – Single Piece												
							<b>Heating Size</b> 00 = No Heat 05 = 5 kW 75 = 7.5 kW 08 = 8 kW 10 = 10 kW 15 = 15 kW 11 = 11 kW					
							<b>Coil Coating</b> 0 = Standard T = ArmorCoat™					
							<b>Capacity</b> 018/019 = 18,000 024/025 = 24,000 030/031 = 30,000 036/037 = 36,000 042/043 = 42,000 048/049 = 48,000 060/061 = 60,000 001 = 18,000 – 36,000 002 = 18,000 – 36,000 003 = 24,000 – 42,000 004 = 24,000 – 42,000 005 = 30,000 – 48,000 006 = 36,000 – 60,000					

FY5B



Use of the AHRI Certified TM Mark indicates a manufacturer's participation in the program. For verification of certification for individual products, go to [www.ahridirectory.org](http://www.ahridirectory.org).



# DIMENSIONS

UNIT	SERIES	ELECTRICAL CHARACTERISTICS				A	B	C	D	E	F	G	H	COIL CONFIGURATION		SHIPPING WT (LBS) NON TIN-COATED	SHIPPING WT (LBS) TIN-COATED
														SLOPE	"A"		
FY5BNF018	A	X	*		47 5/8"	17 5/8"	15 3/4"	15 5/8"	15 3/8"	23 1/8"	23 5/8"	-	X	-	117	117	
FY5BNF024	A	X	*		49 5/8"	17 5/8"	15 3/4"	15 5/8"	15 3/8"	23 1/8"	23 5/8"	-	X	-	128	128	
FY5BNF030	A	X	*		53 7/16"	21 1/8"	19 1/4"	19 1/8"	19 3/16"	26 15/16"	27 1/2"	-	X	-	145	145	
FY5BNF036	A	X	*		53 7/16"	21 1/8"	19 1/4"	19 1/8"	19 3/16"	26 15/16"	27 1/2"	-	X	-	148	148	
FY5BNF042	A	X	*		49 5/8"	21 1/8"	19 1/4"	19 1/8"	15 11/16"	23 7/16"	23 1/8"	-	-	X	156	156	
FY5BNF048	A	X	*		53 7/16"	24 11/16"	22 3/4"	22 11/16"	19 1/2"	27 1/4"	26 15/16"	-	-	X	182	182	
FY5BNB060	A	X	*		59 3/16"	24 11/16"	22 3/4"	22 11/16"	25 1/4"	32 15/16"	32 5/8"	34 1/16"	-	X	196	196	

208/230-1-60	
208/230-3-60	

X=YES  
O=NO  
\*=YES, DUE TO AVAILABLE FIELD INSTALLED HEATERS.

NOTE:  
1. SERIES DESIGNATION IS THE 14TH POSITION OF UNIT PRODUCT NUMBER  
2. ALL DIMENSIONS ARE IN "INCHES" UNLESS NOTED.

NOTE: ALLOW 21" FROM FRONT FOR SERVICE

### UNIT CONNECTION SIZES

SUCTION: 018 & 024 - 5/8" I.D. SWEAT  
030 & 036 - 3/4" I.D. SWEAT  
042 THRU 060 - 7/8" I.D. SWEAT  
LIQUID: 3/8" I.D. SWEAT  
CONDENSATE: 3/4" FPT

FY5B

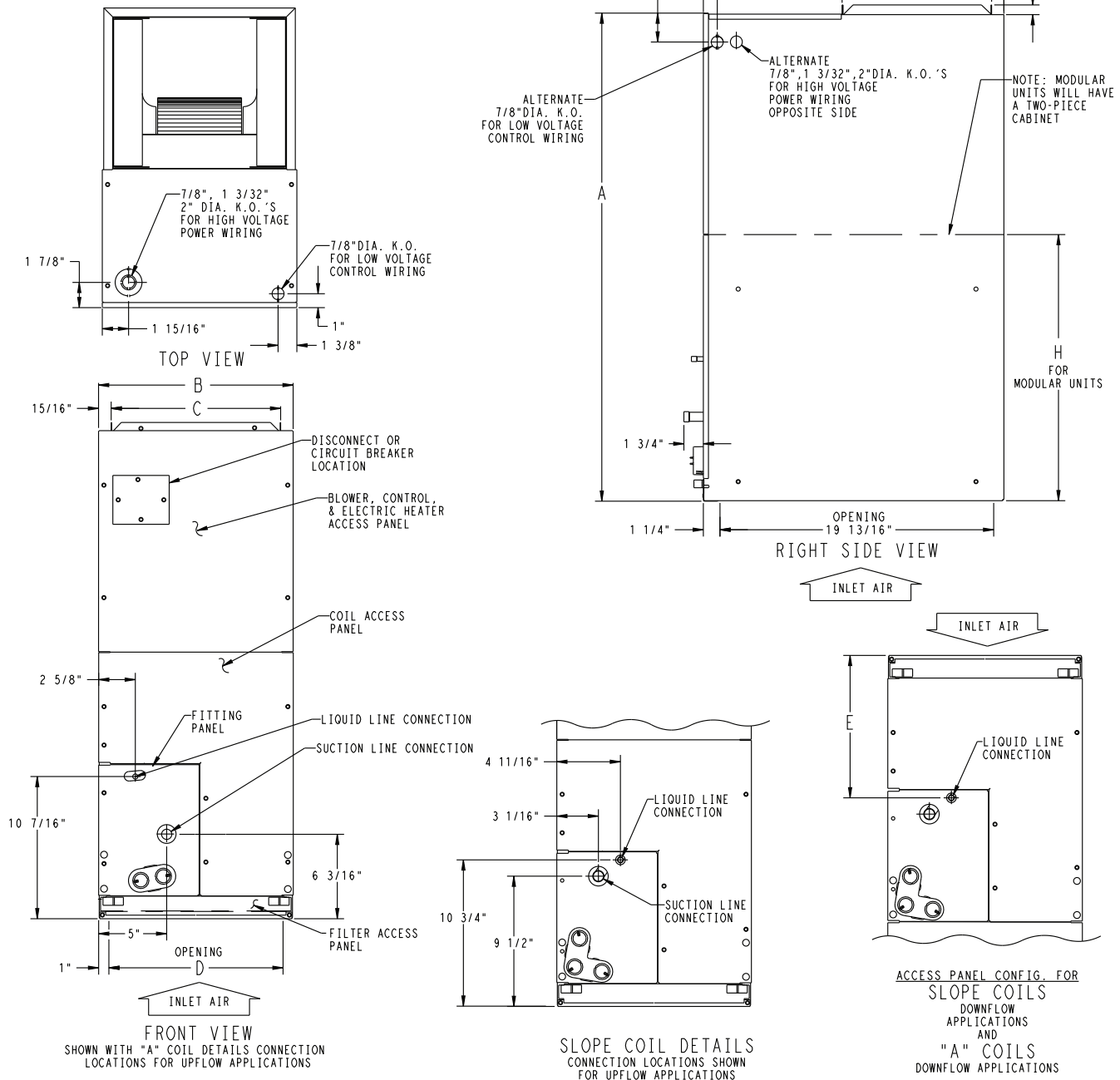

Fig. 1 - FY5B Dimensions - English

A10243

## DIMENSIONS (cont.)

**NOTES:**

1. CONDENSATE PAN DRAIN CAPS NOT SHOWN FOR CLARITY.
2. ALL DIMENSIONS ARE IN "INCHES" UNLESS NOTED.

### SLOPE COIL

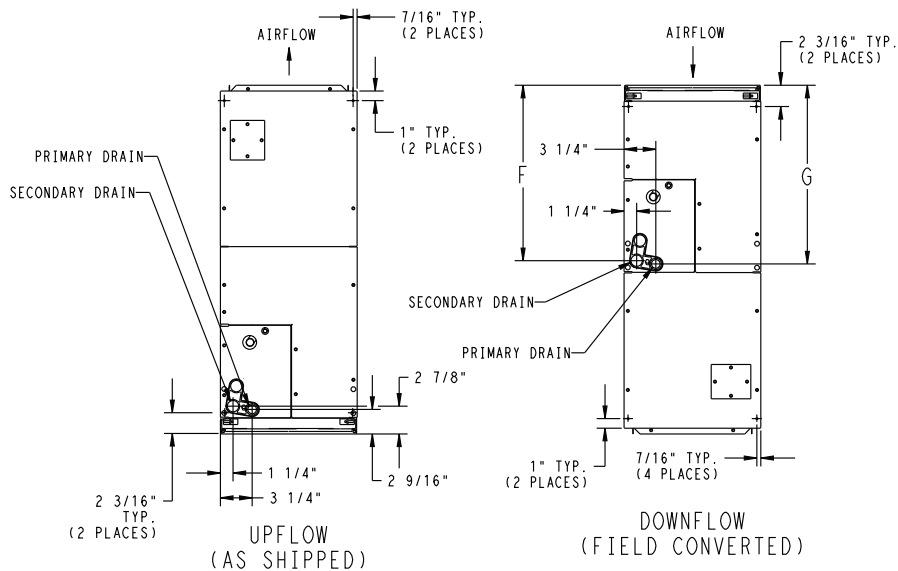

FY5B

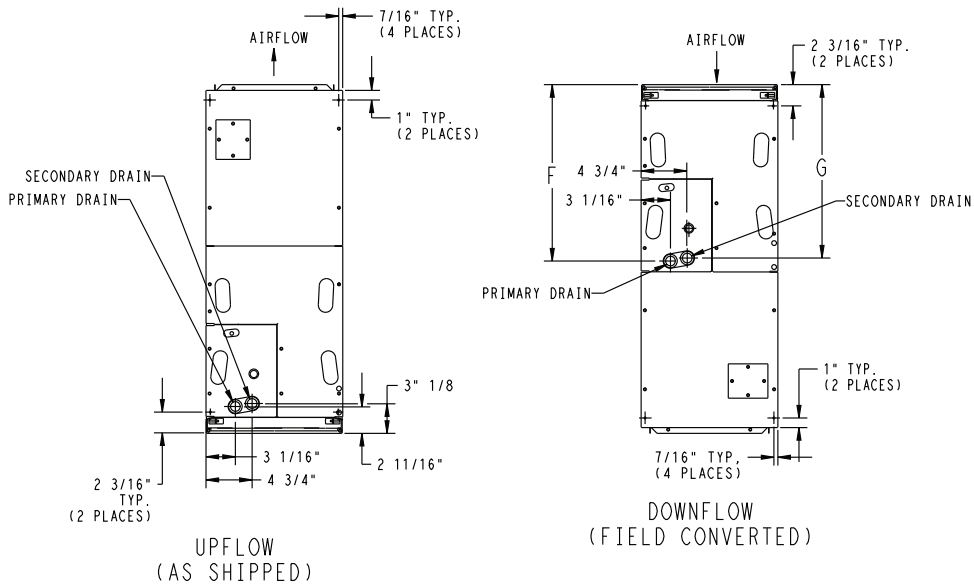

### A-COIL

**Fig. 2 - FY4B Dimensions - English**

A10244

## DIMENSIONS (cont.)

UNIT	SERIES	ELECTRICAL CHARACTERISTICS				A	B	C	D	E	F	G	H	COIL CONFIGURATION		SHIPPING WT (Kgs) NON TIN-COATED	SHIPPING WT (Kgs) TIN-COATED
		SLOPE	"A"	SLOPE	"A"												
FY5BNF018	A	X	*			1209.7	447.7	400.0	396.9	390.5	587.4	600.1	-	X	-	53.1	53.1
FY5BNF024	A	X	*			1260.5	447.7	400.0	396.9	390.5	587.4	600.1	-	X	-	58.1	58.1
FY5BNF030	A	X	*			1357.3	536.6	489.0	485.8	487.4	684.2	698.5	-	X	-	65.8	65.8
FY5BNF036	A	X	*			1357.3	536.6	489.0	485.8	487.4	684.2	698.5	-	X	-	67.1	67.1
FY5BNF042	A	X	*			1260.5	536.6	489.0	485.8	398.5	595.3	587.4	-	-	X	70.8	70.8
FY5BNF048	A	X	*			1357.3	627.1	577.8	576.3	495.3	692.2	684.2	-	-	X	82.6	82.6
FY5BNB060	A	X	*			1503.4	627.1	577.8	576.3	641.4	836.6	828.7	864.5	-	X	88.9	88.9

208/230-1-60  
208/230-3-60

X=YES  
O=NO  
\*YES, DUE TO AVAILABLE FIELD INSTALLED HEATERS.

**NOTE:**

- SERIES DESIGNATION IS THE 14TH POSITION OF UNIT PRODUCT NUMBER
- ALL DIMENSIONS ARE IN "MM" UNLESS NOTED.

NOTE: ALLOW 533.4 FROM FRONT FOR SERVICE

**UNIT CONNECTION SIZES**

SUCTION: 018 & 024 - 15.88 I.D. SWEAT  
030 & 036 - 19.05 I.D. SWEAT  
042 THRU 060 - 22.23 I.D. SWEAT  
LIQUID: 9.53 I.D. SWEAT  
CONDENSATE: 19.0 FPT

**FY5B**

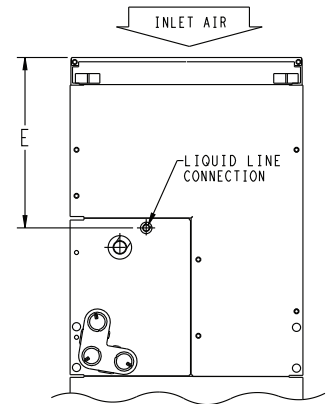
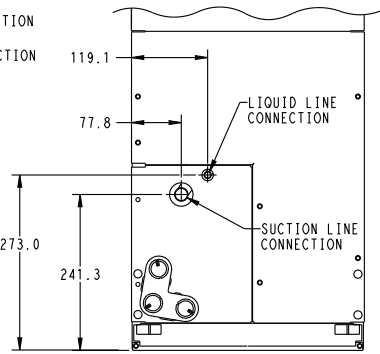
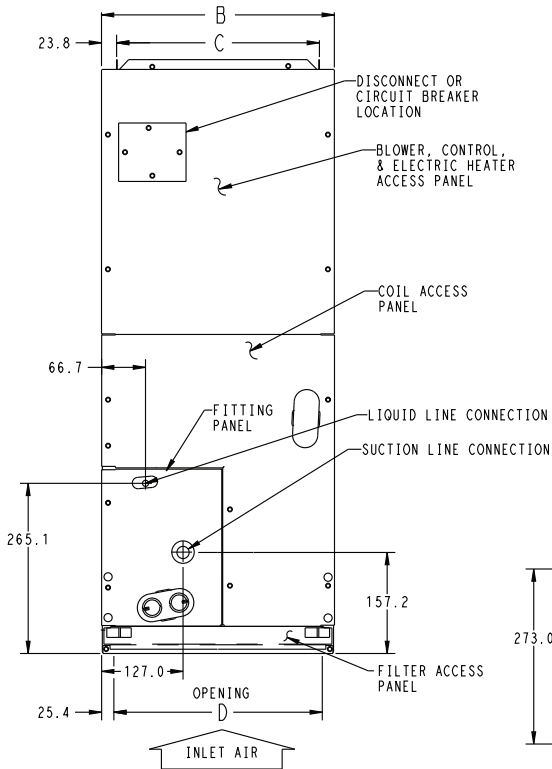
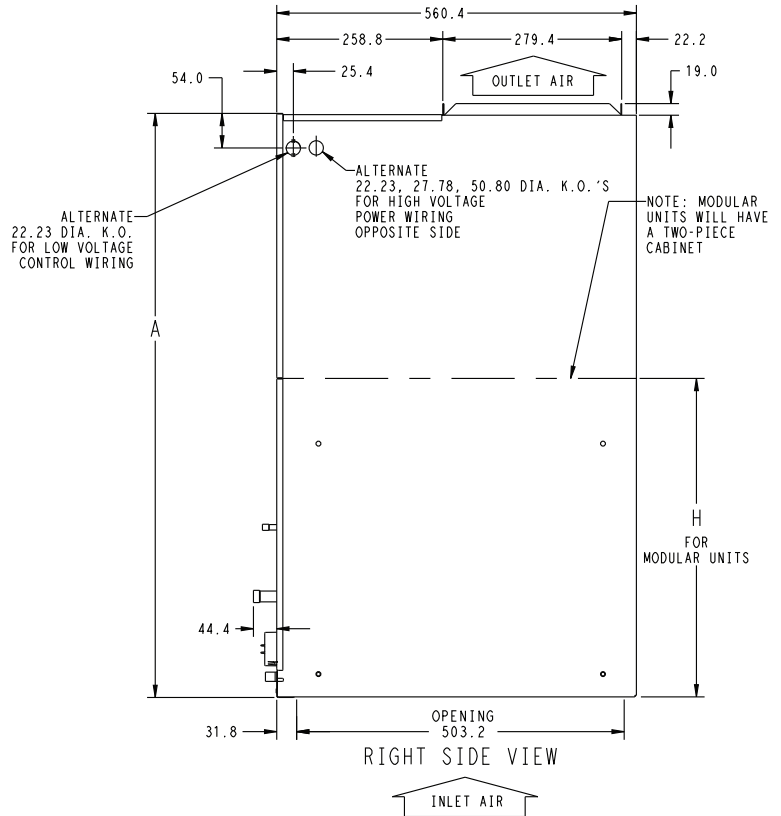
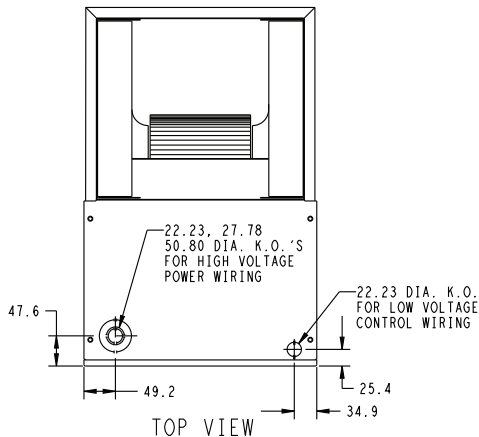

FRONT VIEW  
SHOWN WITH "A" COIL DETAILS CONNECTION LOCATIONS FOR UPFLOW APPLICATIONS

SLOPE COIL DETAILS  
CONNECTION LOCATIONS SHOWN FOR UPFLOW APPLICATIONS

ACCESS PANEL CONFIG. FOR  
SLOPE COILS  
DOWNFLOW APPLICATIONS  
AND  
"A" COILS  
DOWNFLOW APPLICATIONS

**Fig. 3 - FY5B Dimensions - Metric**

A10245

## DIMENSIONS (cont.)

- NOTES:  
 1. CONDENSATE PAN DRAIN CAPS NOT SHOWN FOR CLARITY.  
 2. ALL DIMENSIONS ARE IN "MM" UNLESS NOTED.

### SLOPE COIL

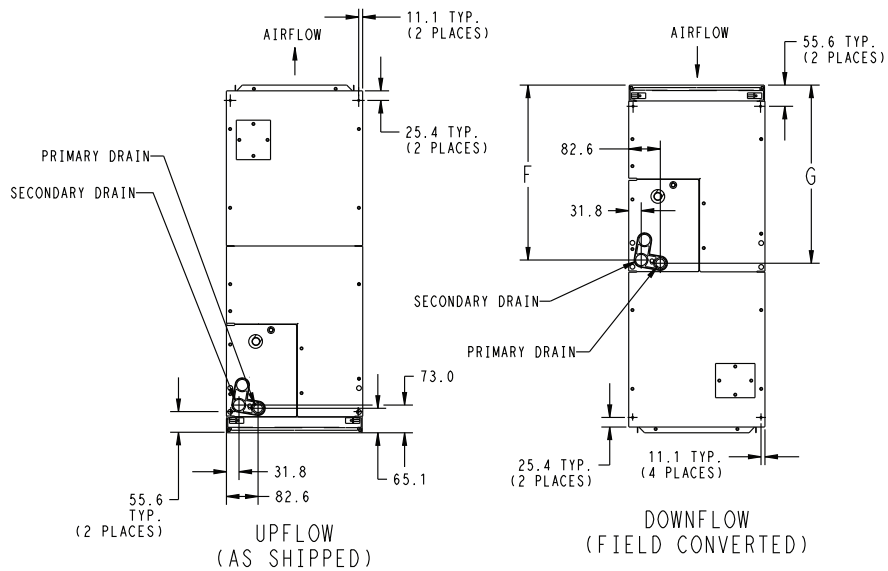

FY5B

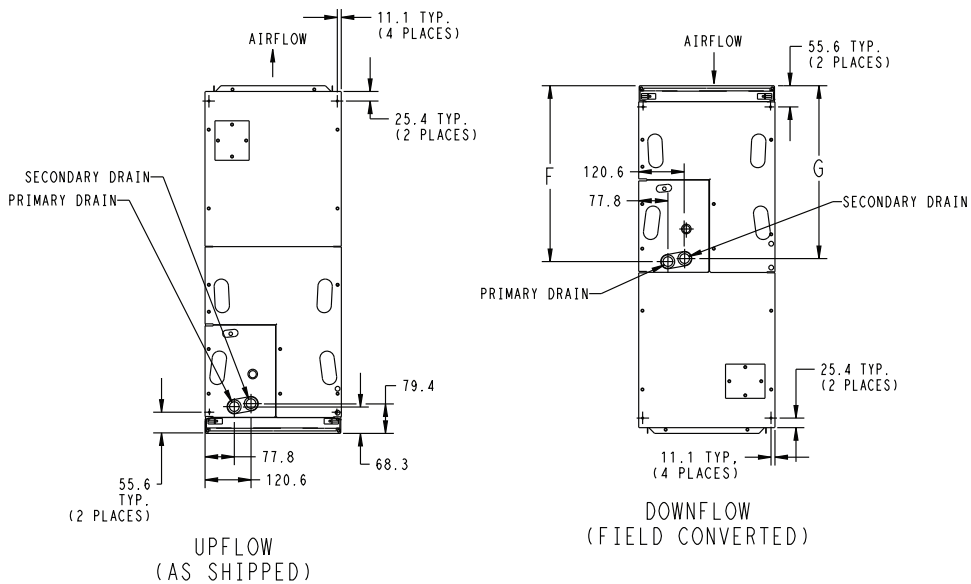

### A-COIL

**Fig. 4 - FY5B Dimensions - Metric**

A10246

## PHYSICAL DATA

ORDERING NO.	FACTORY INSTALLED HEAT (kW)	NOMINAL COOLING CAPACITY (BTUH)	DIMENSIONS			SHIPPING WEIGHT
			Height	Width	Depth	
FY5BNF018(T,0)00	–	18,000	47 5/8–in 1210mm	17–5/8–in 447mm	22–1/16–in 560mm	117 lb 53 kg
FY5BNF018(T,0)05	5					
FY5BNF018(T,0)08	8					
FY5BNF024(T,0)00	–	24,000	49–5/8–in 1260mm	17–5/8–in 447mm	22–1/16–in 560mm	128 lb 58 kg
FY5BNF024(T,0)05	5					
FY5BNF024(T,0)10	10					
FY5BNF030(T,0)00	–	30,000	53–7/16–in 1357mm	21–1/8–in 536mm	22–1/16–in 560mm	145 lb 66kg
FY5BNF030(T,0)08	8					
FY5BNF030(T,0)10	10					
FY5BNF036(T,0)00	–	36,000	53–7/16–in 1357mm	21–1/8–in 536mm	22–1/16–in 560mm	148 lb 67 kg
FY5BNF036(T,0)10	10					
FY5BNF036(T,0)15	15					
FY5BNF042(T,0)00	–	42,000	49–5/8–in 1260mm	21–1/8–in 536mm	22–1/16–in 560mm	156 lb 71 kg
FY5BNF042(T,0)10	10					
FY5BNF042(T,0)15	15					
FY5BNF048(T,0)00	–	48,000	53–7/16–in 1357mm	24–11/16–in 627mm	22–1/16–in 560mm	182 lb 83 kg
FY5BNF048(T,0)10	10					
FY5BNF048(T,0)15	15					
FY5BNB060(T,0)00	–	60,000	59–3/16–in 1503mm	24–11/16–in 627mm	22–1/16–in 560mm	196 lb 89 kg
FY5BNB060(T,0)15	15					

**6th digit:** B – Modular cabinet, C – Disconnect, F – Single piece cabinet

**10th digit:** 0 – Standard copper coil, T – ArmorCoat™

## SPECIFICATIONS

MODEL FY5B	018	024	030	036	042	048	060
<b>COIL</b>							
Rows/Fins Per In.	3 / 14.5						
Face Area (Sq. Ft.)	2.97	2.97	3.46	3.46	4.45	5.93	7.42
Configuration	Slope				A		
Metering Device (Teflon–ring piston) Puron® Refrigerant	EA52PT052	EA52PT057	EA52PT067	EA52PT070	EA52PT076	EA52PT080	N/A <sup>1</sup>
<b>FAN</b>							
CFM (Nominal)	600	800	1000	1200	1400	1600	2000
Motor Type	PSC	PSC	PSC	PSC	PSC	PSC	PSC
Motor Hp	1/6	1/4	1/3	1/3	1/2	1/2	3/4
<b>FILTER*</b>							
21–1/2–in (546 mm) X	13–in (330 mm)	16–3/8–in (417 mm)		19–7/8–in (505 mm)		23–5/16–in (585 mm)	
<b>CABINET CONFIGURATION OPTIONS</b>							
	1–piece	1–piece	1–piece	1–piece	1–piece	1–piece	Modular

\*Filter must be field–supplied for FY5B units.

<sup>1</sup> 5 ton (060) model utilizes a factory installed bi–flow TXV

FY5B



## PERFORMANCE DATA

### AIRFLOW PERFORMANCE (CFM)

FY5B SIZE	BLOWER SPEED	0.10		0.20		0.30		0.40		0.50		0.60	
		208V	230V	208V	230V	208V	230V	208V	230V	208V	230V	208V	230V
018	High	742	825	707	768	642	714	568	648	466	526	403	434
	Low	541	608	480	564	417	511	357	431	299	363	n/a	304
024	High	1041	1112	969	1030	888	936	774	791	573	654	341	438
	Low	874	1014	838	953	781	868	684	740	506	573	341	418
030	High	1256	1327	1186	1242	1071	1132	952	1005	704	791	459	482
	Low	965	1117	949	1074	916	1019	805	902	575	637	396	447
036	High	1306	1490	1264	1418	1207	1338	1135	1241	1043	1127	842	937
	Low	1164	1335	1144	1290	1108	1226	1052	1148	970	1048	697	855
042	High	1723	1768	1639	1681	1544	1576	1435	1465	1309	1340	1144	1182
	Low	1387	1543	1358	1488	1311	1410	1237	1315	1137	1200	997	1047
048	High	1902	1941	1803	1867	1706	1767	1593	1648	1472	1512	1303	1371
	Low	1671	1777	1630	1711	1563	1630	1479	1528	1370	1412	1218	1266
060	High	2064	2128	1989	2050	1906	1965	1819	1875	1725	1778	1624	1674
	Med	1812	1959	1756	1898	1692	1829	1619	1750	1538	1663	1449	1566
	Low	1556	1748	1521	1709	1477	1659	1422	1598	1357	1525	1283	1442

■ – Shading – Airflow outside 450 cfm/ton.

**NOTES:**

1. Airflow based upon dry coil at 230v with factory–approved filter and electric heater (2 element heater sizes 18 thru 36, 3 element heater sizes 42 thru 60). Airflow at 208 volts is approximately 10% lower.
2. To avoid potential for condensate blowing out of drain pan prior to making drain trap: Return static pressure must be less than 0.40 in wc.
3. Airflow above 400 cfm/ton on 048–060 size could result in condensate blowing off coil or splashing out of drain pan.

FY5B

**PERFORMANCE DATA (cont.)**

**GROSS COOLING CAPACITIES (mbh) - Puron® Refrigerant**

FY5B SIZE	INDOOR COIL AIR		SATURATED TEMPERATURE LEAVING EVAPORATOR (°F / °C)														
			35 / 2			40 / 4			45 / 7			50 / 10			55 / 13		
	CFM	EWB	TC	SHC	BF	TC	SHC	BF	TC	SHC	BF	TC	SHC	BF	TC	SHC	BF
018	525	72 / 22	37	19	0.00	33	17	0.00	29	15	0.00	24	13	0.01	19	11	0.02
		67 / 19	30	20	0.02	26	17	0.02	22	15	0.03	17	13	0.03	12	11	0.03
		62 / 17	24	20	0.03	20	17	0.03	16	15	0.03	12	12	0.10	10	10	0.26
	600	72 / 22	41	21	0.00	37	19	0.00	32	17	0.01	27	14	0.02	21	12	0.03
		67 / 19	34	22	0.03	29	19	0.03	24	17	0.03	19	14	0.04	13	12	0.04
		62 / 17	27	22	0.04	22	20	0.04	18	17	0.04	14	14	0.11	11	11	0.27
	675	72 / 22	45	23	0.00	40	21	0.00	35	18	0.02	29	16	0.03	23	13	0.04
		67 / 19	37	24	0.04	32	21	0.04	27	19	0.04	21	16	0.05	15	13	0.05
		62 / 17	29	24	0.05	24	22	0.05	19	19	0.05	15	15	0.13	12	12	0.29
024	700	72 / 22	42	23	0.00	38	20	0.00	33	18	0.00	27	15	0.02	21	12	0.03
		67 / 19	34	23	0.03	30	20	0.03	25	18	0.03	20	15	0.03	13	12	0.04
		62 / 17	27	23	0.03	23	21	0.03	18	18	0.04	14	14	0.11	11	11	0.27
	800	72 / 22	47	25	0.00	42	22	0.00	36	20	0.01	30	17	0.03	24	14	0.04
		67 / 19	38	25	0.04	33	23	0.04	28	20	0.04	22	17	0.04	15	14	0.05
		62 / 17	30	26	0.04	25	23	0.04	20	20	0.05	16	16	0.13	13	13	0.29
	900	72 / 22	51	27	0.00	46	24	0.00	40	21	0.03	33	18	0.04	26	15	0.05
		67 / 19	42	28	0.05	36	25	0.05	30	22	0.05	23	19	0.05	16	15	0.06
		62 / 17	33	28	0.05	27	25	0.05	22	22	0.06	17	17	0.15	14	14	0.30
030	875	72 / 22	60	31	0.00	53	27	0.00	47	24	0.01	39	21	0.02	31	17	0.03
		67 / 19	48	31	0.03	42	28	0.03	35	24	0.04	28	21	0.04	19	17	0.04
		62 / 17	38	31	0.04	32	28	0.04	26	25	0.04	20	20	0.11	16	16	0.27
	1000	72 / 22	66	34	0.00	59	30	0.00	51	27	0.02	43	23	0.04	34	19	0.04
		67 / 19	54	35	0.04	47	31	0.04	39	27	0.05	31	23	0.05	22	19	0.05
		62 / 17	43	35	0.05	36	31	0.05	28	27	0.06	22	22	0.13	18	18	0.29
	1125	72 / 22	72	37	0.00	64	33	0.00	56	29	0.03	47	25	0.05	37	21	0.05
		67 / 19	58	38	0.05	51	34	0.05	42	30	0.06	33	25	0.06	23	21	0.07
		62 / 17	46	38	0.06	39	34	0.06	31	30	0.07	25	25	0.15	20	20	0.30
036	1050	72 / 22	66	34	0.00	59	31	0.00	51	27	0.03	43	23	0.04	33	19	0.05
		67 / 19	53	35	0.05	46	31	0.05	39	28	0.05	30	24	0.05	21	20	0.06
		62 / 17	42	36	0.05	35	32	0.05	28	28	0.06	22	22	0.14	18	18	0.29
	1200	72 / 22	72	38	0.00	64	34	0.00	56	30	0.04	47	26	0.05	37	21	0.06
		67 / 19	59	39	0.06	51	35	0.06	43	31	0.06	33	26	0.06	23	22	0.07
		62 / 17	47	40	0.07	39	35	0.07	31	31	0.08	25	25	0.16	20	20	0.31
	1350	72 / 22	78	41	0.00	70	37	0.02	61	32	0.05	51	28	0.06	40	23	0.07
		67 / 19	64	42	0.07	55	38	0.07	46	33	0.07	36	29	0.08	25	24	0.09
		62 / 17	51	43	0.08	42	39	0.08	34	34	0.09	27	27	0.19	22	22	0.33
042	1225	72 / 22	80	41	0.00	72	37	0.00	62	33	0.02	52	28	0.03	41	23	0.04
		67 / 19	65	42	0.04	57	38	0.04	47	33	0.04	37	29	0.04	26	24	0.05
		62 / 17	52	43	0.04	43	38	0.04	34	34	0.05	27	27	0.12	22	22	0.28
	1400	72 / 22	88	46	0.00	79	41	0.00	69	36	0.03	57	31	0.04	45	26	0.05
		67 / 19	72	47	0.05	62	42	0.05	52	37	0.05	41	32	0.05	29	26	0.06
		62 / 17	57	48	0.06	48	43	0.06	38	38	0.06	30	30	0.14	25	25	0.29
	1575	72 / 22	95	50	0.00	85	45	0.00	74	39	0.04	62	34	0.05	49	28	0.06
		67 / 19	78	51	0.06	68	46	0.06	57	40	0.06	44	35	0.07	31	29	0.07
		62 / 17	62	52	0.07	52	47	0.07	41	41	0.08	33	33	0.17	27	27	0.31
048	1400	72 / 22	89	48	0.00	80	43	0.00	70	38	0.00	58	32	0.02	46	27	0.03
		67 / 19	73	49	0.03	63	43	0.03	53	38	0.03	42	33	0.03	29	27	0.04
		62 / 17	58	49	0.03	48	44	0.03	38	38	0.04	30	30	0.10	25	25	0.26
	1600	72 / 22	99	53	0.00	88	47	0.00	77	42	0.01	65	36	0.03	51	30	0.04
		67 / 19	80	54	0.04	70	48	0.04	59	42	0.04	46	36	0.04	33	30	0.05
		62 / 17	64	55	0.04	53	49	0.04	42	43	0.05	33	33	0.12	28	28	0.28
	1800	72 / 22	107	57	0.00	96	52	0.00	84	45	0.03	70	39	0.04	55	32	0.05
		67 / 19	88	59	0.05	76	53	0.05	64	46	0.05	50	40	0.05	35	33	0.06
		62 / 17	70	60	0.05	58	54	0.05	46	47	0.06	37	37	0.14	30	30	0.29
060	1600	72 / 22	102	54	0.00	92	49	0.00	81	43	0.00	68	37	0.01	54	31	0.02
		67 / 19	83	55	0.02	73	49	0.02	62	43	0.02	49	37	0.03	35	31	0.03
		62 / 17	66	56	0.03	56	50	0.03	45	44	0.03	35	35	0.09	29	29	0.24
	1750	72 / 22	109	58	0.00	99	52	0.00	86	46	0.01	73	40	0.02	58	33	0.02
		67 / 19	89	59	0.03	78	53	0.03	66	47	0.03	52	40	0.03	37	34	0.03
		62 / 17	71	60	0.03	60	54	0.03	48	47	0.04	38	38	0.10	31	31	0.25
	2000	72 / 22	121	64	0.00	109	57	0.00	95	51	0.02	80	44	0.03	64	37	0.03
		67 / 19	99	66	0.04	86	59	0.04	73	52	0.04	58	45	0.04	41	37	0.05
		62 / 17	79	67	0.04	66	60	0.04	53	53	0.05	42	42	0.12	35	35	0.27

See Notes following table.

FY5B

## PERFORMANCE DATA (cont.)

**CFM** – Cubic Ft per Minute  
**SHC** – Gross Sensible Capacity 1000 Btuh

**EWB** – Entering Wet Bulb °F (°C)  
**BF** – Bypass Factor

**LWB** – Leaving Wet Bulb °F (°C)    **TC** – Gross Cooling Capacity 1000 Btuh  
**MBH** – 1000 Btuh

**NOTES:**

1. Contact manufacturer for cooling capacities at conditions other than shown in table.
2. Formulas:  
 Leaving db = entering db -  $\frac{\text{sensible heat cap.}}{1.09 \times \text{CFM}}$   
 Leaving wb = wb corresponding to enthalpy of air leaving coil ( $h_{lwb}$ )  
 $h_{lwb} = h_{ewb} - \frac{\text{total capacity (Btuh)}}{4.5 \times \text{CFM}}$   
 where  $h_{ewb}$  = enthalpy of air entering coil. Direct interpolation is permissible. Do not extrapolate.
3. SHC is based on 80°F (27°C) db temperature of air entering coil. Below 80°F (27°C) db, subtract (Correction Factor x CFM) from SHC. Above 80°F (27°C) db, add (Correction Factor x CFM) to SHC.
4. Bypass Factor = 0 indicates no psychometric solution. Use bypass factor of next lower EWB for approximation.

### SHC CORRECTION FACTOR

BYPASS FACTOR	ENTERING AIR DRY-BULB TEMPERATURE (°F)					
	79	78	77	76	75	Under 75
	81	82	83	84	85	Over 85
	ENTERING AIR DRY-BULB TEMPERATURE (°C)					
	26	25	25	24	24	Under 75
	27	28	28	29	29	Over 85
Correction Factor						
0.10	.098	1.96	2.94	3.92	4.91	Use formula shown below
0.20	0.87	1.74	2.62	3.49	4.36	
0.30	0.76	1.53	2.29	3.05	3.82	

Interpolation is permissible.

Correction Factor =  $1.09 \times (1 - \text{BF}) \times (\text{db} - 80)$

**FY5B**

### MINIMUM CFM AND MOTOR SPEED SELECTION

FY5B SIZE	HEATER kW									
	3	5	8	9	10	15	18	20	24	30
018	525	525	525	—	600	—	—	—	—	—
024	700	700	700	—	700	775	—	—	—	—
030	—	875	875	—	875	875	—	1060	—	—
036	—	1050	970	970	970	920	—	1040	—	—
042	—	—	1225	1225	1225	1225	1225	1225	—	—
048	—	—	1400	1400	1400	1400	1400	1400	1400	1400
060	—	—	1750	1750	1750	1750	1750	1750	1750	1750

**NOTE:** Values indicate low or medium speed.

### AIR DELIVERY PERFORMANCE CORRECTION COMPONENT PRESSURE DROP (in wc) AT INDICATED AIRFLOW (DRY-TO-WET COIL)

FY5B SIZE	CFM															
	500	600	700	800	900	1000	1100	1200	1300	1400	1500	1600	1700	1800	1900	2000
18	0.016	0.027	0.038	—	—	—	—	—	—	—	—	—	—	—	—	—
24	0.016	0.027	0.038	0.049	0.059	—	—	—	—	—	—	—	—	—	—	—
30	—	—	—	0.036	0.046	0.055	0.064	—	—	—	—	—	—	—	—	—
36	—	—	—	—	—	0.055	0.064	0.073	0.081	—	—	—	—	—	—	—
42	—	—	—	—	—	—	—	0.049	0.056	0.063	0.07	—	—	—	—	—
48	—	—	—	—	—	—	—	—	—	0.038	0.043	0.049	0.054	0.059	—	—
60	—	—	—	—	—	—	—	—	—	—	—	0.031	0.036	0.04	0.044	0.049

### FIELD-INSTALLED ACCESSORY FILTER STATIC PRESSURE DROP (in wc)

FY5B SIZE	CFM								
	400	600	800	1000	1200	1400	1600	1800	2000
018, 024	0.012	0.022	0.048	0.072	—	—	—	—	—
030, 036, 042	—	—	0.036	0.051	0.07	0.092	0.12	—	—
048, 060	—	—	—	—	—	0.073	0.086	0.105	0.13

## PERFORMANCE DATA (cont.)

### ELECTRIC HEATER STATIC PRESSURE DROP (in. wc)

018 – 036			042 – 060		
HEATER ELEMENTS	kW	EXTERNAL STATIC PRESSURE CORRECTION	HEATER ELEMENTS	kW	EXTERNAL STATIC PRESSURE CORRECTION
0	0	+ .02	0	0	+ .04
1	3, 5	+ .01	2	8, 10	+ .02
2	8, 10	0	3	9, 15	0
3	9, 15	- .02	4	20	- .02
4	20	- .04	6	18, 24, 30	- .10

The airflow performance data was developed using fan coils with 10–kW electric heaters (2 elements) in the 018 through 036 size units and 15–kW heaters (3 elements) in the 042 through 060 size units. For fan coils with heaters of a different number of elements, the external available static at a given CFM from the curve may be corrected by adding or subtracting available external static pressure as indicated above.

### ACCESSORY ELECTRIC HEATERS

HEATER PART NO.	kW @ 240V	VOLTS/ PH	STAGES (kW OPERATING)	INTERNAL CIRCUIT PROTECTION	FAN COIL SIZE USED WITH	HEATING CAP.** @ 230V
KFCEH0401N03	3	230/1	3	None	018–024	9,400
KFCEH0501N05	5	230/1	5	None	018–060	15,700
KFCEH0801N08	8	230/1	8	None	018–060	25,100
KFCEH0901N10	10	230/1	10	None	018–060	31,400
KFCEH3201F20	20	230/1	5, 20	Fuse‡	030–060	62,800
KFCEH1601315	15	230/3	5, 15	None	036–060	47,100
KFCEH2001318	18	230/3	6, 12, 18	None	042–060	56,500
KFCEH3401F24	24	230/3*	8, 16, 24	Fuse	048, 060	78,300
KFCEH3501F30	30	230/3*	10, 20, 30	Fuse	048, 060	94,100
KFCEH2401C05	5	230/1	5	Circuit Breaker	018–060	15,700
KFCEH2501C08	8	230/1	8	Circuit Breaker	018–060	25,100
KFCEH2601C10	10	230/1	10	Circuit Breaker	018–060	31,400
KFCEH3301C20	20	230/1	5, 20	Circuit Breaker	030–060	62,800
KFCEH2901N09	9	230/1†	3, 9	None	036–060	28,200
KFCEH3001F15	15	230/1	5, 15	Fuse‡	024–060	47,100
KFCEH3101C15	15	230/1	5, 15	Circuit Breaker	024–060	47,100

\* Field convertible to 1 phase.

† Field convertible to 3 phase.

‡ Single point wiring kit required for these heaters in Canada.

\*\* Blower motor heat not included.

### ESTIMATED SOUND POWER LEVEL (dBA)

FY5B SIZE	CONDITIONS		OCTAVE BAND CENTER FREQUENCY*						
	CFM	Ext Static Pressure	63	125	250	500	1000	2000	4000
018	600	0.25	64.7	60.7	56.7	53.7	51.7	49.7	45.7
024	800	0.25	66.0	62.0	58.0	55.0	53.0	51.0	47.0
030	1000	0.25	67.0	63.0	59.0	56.0	54.0	52.0	48.0
036	1200	0.25	67.8	63.8	59.8	56.8	54.8	52.8	48.8
042	1400	0.25	68.4	64.4	60.4	57.4	55.4	53.4	49.4
048	1600	0.25	69.0	65.0	61.0	58.0	56.0	54.0	50.0
060	2000	0.25	70.0	66.0	62.0	59.0	57.0	55.0	51.0

\* Est. sound power levels have been derived using the method described in the 1987 ASHRAE HVAC Systems & Applications Handbook, Chap. 52, p. 52.7.

**PERFORMANCE DATA (cont.)**

**ELECTRICAL DATA FOR UNITS WITH FACTORY-INSTALLED HEATERS**

MODEL	MTR HP	MTR FLA	HEAT PACK INSTALLED	SINGLE CIRCUIT			DUAL CIRCUIT					
				HTR AMPS	MCA	MOCP	HTR AMPS	MCA	MOCP	HTR AMPS	MCA	MOCP
							L1/L2	L1/L2	L1/L2	L3/L4	L3/L4	L3/L4
FY5BNF 018(0,T)05	1/6	0.9	MKFCEH0501N05	18.1/20.0	23.8/26.2	25/30	-	-	-	-	-	-
FY5BNF018(0,T)08	1/6	0.9	MKFCEH0801N08	28.9/32.0	37.3/41.2	40/45	-	-	-	-	-	-
FY5BNF024(0,T)05	1/4	1.4	MKFCEH0501N05	18.1/20.0	24.4/26.8	25/30	-	-	-	-	-	-
FY5BNF024(0,T)10	1/4	1.4	MKFCEH0901N10	36.2/40.0	47.0/51.8	50/60	-	-	-	-	-	-
FY5BNF030(0,T)08	1/3	1.4	MKFCEH0801N08	28.9/32.0	37.9/41.8	40/45	-	-	-	-	-	-
FY5BNF030(0,T)10	1/3	1.4	MKFCEH0901N10	36.2/40.0	47.0/51.8	50/60	-	-	-	-	-	-
FY5BNF036(0,T)10	1/3	1.7	MKFCEH0901N10	36.2/40.0	47.4/52.2	50/60	-	-	-	-	-	-
FY5BNF036(0,T)15	1/3	1.7	MKFCEH1501F15	54.2/59.9	69.9/77.0	80/80	36.2/40.0	48.3/53.0	50/60	18.1/20.0	22.6/25.0	25/25
FY5BNF042(0,T)10	1/2	2.8	MKFCEH0901N10	36.2/40.0	48.8/53.5	50/60	-	-	-	-	-	-
FY5BNF042(0,T)15	1/2	2.8	MKFCEH1501F15	54.2/59.9	71.3/78.4	80/80	36.2/40.0	48.9/53.6	50/60	18.1/20.0	22.6/25.0	25/25
FY5BNF048(0,T)10	1/2	2.7	MKFCEH0901N10	36.2/40.0	48.7/53.4	50/60	-	-	-	-	-	-
FY5BNF048(0,T)15	1/2	2.7	MKFCEH1501F15	54.2/59.9	71.2/78.3	80/80	36.2/40.0	50.6/55.4	60/60	18.1/20.0	22.6/25.0	25/25
FY5BNB060(0,T)15	3/4	5.2	MKFCEH1501F15	54.2/59.9	74.3/81.4	80/90	36.2/40.0	51.8/56.5	60/60	18.1/20.0	22.6/25.0	25/25

**NOTE:** All units 208/230, single-phase, 60 Hz

**MCA** – Minimum Circuit Amps

**FLA** – Full Load Amps

**FY5B**

## PERFORMANCE DATA (cont.)

MODEL NO	MTR HP	MTR FLA	MCA	MOCP	MIN WIRE SIZE AWG*
FY5BNF018T00	1/6	0.9	1.2	15	14
FY5BNF018000					
FY5BNF024T00	1/4	1.4	1.8	15	14
FY5BNF024000					
FY5BNF030T00	1/3	1.4	1.8	15	14
FY5BNF030000					
FY5BNF036T00	1/3	1.7	2.2	15	14
FY5BNF036000					
FY5BNF042T00	1/2	2.8	3.5	15	14
FY5BNF042000					
FY5BNF048T00	1/2	2.7	3.4	15	14
FY5BNF048000					
FY5BNB060T00	3/4	5.2	6.5	15	14
FY5BNB060000					

\* Use copper wire only. Use 75°C only in this application. When using non-metallic (NM) sheathed cable, wire size required should be based on that of 60°C conductors, instead of wire sizes shown in table above per NEC Article 336-26.

**NOTES:** If branch circuit wire length exceeds 100 ft. (30m), consult NEC 215-2 to determine maximum wire length. Use 2% voltage drop. All units 208/230, single-phase, 60 Hz.

**FLA** – Full Load Amps

### FACTORY-INSTALLED HEATER OPTIONS\*

MODEL	018	024	030	036	042	048	060
FY5BN(F,B)	5, 8	5, 10	8, 10	10, 15	10, 15	10, 15	15

\* For field-installed heater/fan coil combinations, see Electric Heater Internal Protection below.

**6th digit:** B – Modular cabinet, F – Single piece cabinet

### ELECTRIC HEATER INTERNAL PROTECTION\*

HEATER KW	PHASE	FUSE QTY/SIZE	CKT BKR QTY/SIZE†
3	1	—	—
5	1	—	1/60
8	1	—	1/60
10	1	—	1/60
15	1	2/30 — 2/60	2/60
20	1	4/60	2/60
24	1/3	6/60	—
30	1/3	6/60	—
9	1/3	—	—
15	3	—	—
18	3	—	—

\* 5-, 8-, 10-kW factory-installed heat has no internal protection. 15-kW factory-installed heat is internally protected with fuses.

† Circuit breakers are 2 pole.

## ACCESSORY ELECTRIC HEATER ELECTRICAL DATA

HEATER PART NO.	kW		INTERNAL CIRCUIT PROTECTION	HEATER AMPS 208/230V				Min Wire Size (AWG) 208/230V†				Max Fuse/Ckt Bkr Amps 208/230V				Max Wire Length 208/230V (Ft)‡	
	240v	208v		Single Circuit	Dual Circuit		Single Circuit	Dual Circuit		Single Circuit	Dual Circuit		Single Circuit	Dual Circuit		Single Circuit	Dual Circuit
					L1,L2	L3,L4		L1,L2	L3,L4		L1, L2	L3, L4		L1,L2	L3,L4		
KFCEH0401N03	3	2.3	1	None	10.9/12.0	—	—	12/12	—	—	20/20	—	—	67/68	—	—	
KFCEH0501N051	5	3.8	1	None	18.1/20.0	—	—	10/10	—	—	30/30	—	—	66/66	—	—	
KFCEH0601N052	5	3.8	1	None	18.1/20.0	—	—	8/8	—	—	35/35	—	—	65/68	—	—	
KFCEH2401C051	5	3.8	1	CHt Bkr	18.1/20.0	—	—	10/10	—	—	30/30	—	—	66/66	—	—	
KFCEH3401C052	5	3.8	1	CHt Bkr	18.1/20.0	—	—	8/8	—	—	35/35	—	—	65/68	—	—	
KFCEH0801N08	8	6.0	1	None	26.9/32.0	—	—	8/8	—	—	45/50	—	—	58/60	—	—	
KFCEH2501C08	8	6.0	1	CHt Bkr	26.9/32.0	—	—	8/8	—	—	45/50	—	—	58/60	—	—	
KFCEH2901N09	9	6.8	1	None	32.6/36.0	—	—	8/6	—	—	50/60	—	—	54/67	—	—	
KFCEH2901N09**	9	6.8	3	None	16.8/20.8	—	—	8/6	—	—	35/35	—	—	63/65	—	—	
KFCEH0901N10	10	7.5	1	None	36.2/40.0	—	—	6/6	—	—	60/60	—	—	78/80	—	—	
KFCEH2601C10	10	7.5	1	CHt Bkr	36.2/40.0	—	—	53.8/58.5	—	—	60/60	—	—	78/80	—	—	
KFCEH3001F15	15	11.3	1	Fuse	54.2/59.9	36.2/40.0	18.1/20.0	76.3/83.4	53.8/58.5	22.7/25.0	80/80	60/60	25/25	88/89	78/80	75/76	
KFCEH3101C15	15	11.3	1	CHt Bkr	—	36.2/40.0	18.1/20.0	—	53.8/58.5	22.7/25.0	—	—	60/60	—	78/80	75/76	
KFCEH1601315	15	11.3	3	None	31.3/34.6	—	—	47.7/51.8	—	—	50/60	—	—	56/60	—	—	
KFCEH2001318	18	13.5	3	None	37.6/41.5	—	—	55.5/60.4	—	—	60/70	—	—	76/77	—	—	
KFCEH3201F20	20	15.0	1	Fuse	72.3/79.9	36.2/40.0	36.2/40.0	98.9/108.4	53.8/58.5	45.3/50.0	100/110	60/60	50/50	85/109	78/80	59/59	
KFCEH3301C20	20	15.0	1	CHt Bkr	—	36.2/40.0	36.2/40.0	—	53.8/58.5	45.3/50.0	—	—	60/60	—	78/80	59/59	
KFCEH3401F24††	24	18.0	3	Fuse	50.1/55.4	—	—	71.2/77.8	—	—	80/80	—	—	94/95	—	—	
	24	18.0	1	Fuse	66.7/65.5	—	—	118.9/127.9	—	—	129/150	—	—	115/116	—	—	
	30	22.5	3	Fuse	62.6/69.2	—	—	86.8/95.0	—	—	90/100	—	—	97/98	—	—	
KFCEH3501F30††	30	22.5	1	Fuse	109.0/120.0	—	—	144.8/158.5	—	—	150/175	—	—	117/150	—	—	

## FIELD MULTIPOINT WIRING OF 24-AND 30-KW SINGLE PHASE

HEATER PART NO.	kW		P H A S E	HEATER AMPS 208/230V						MIN WIRE SIZE (AWG) 208/230V†						MIN AMPACITY 208/230V*						MAX FUSE/CKT BKR AMPS 208/230V						MAX WIRE LENGTH 208/230V (FT)‡					
	240V	208V		Single		Dual		Dual		Single	Dual		Single	Dual		Single	Dual		Single	Dual		Single	Dual		Single	Dual		Single	Dual				
				L1,L2	L3,L4	L5,L6	L1,L2	L3,L4	L5,L6		L1,L2	L3,L4		L5,L6	L1,L2		L3,L4	L5,L6		L1,L2	L3,L4		L5,L6	L1,L2		L3,L4	L5,L6		L1,L2	L3,L4	L5,L6		
KFCEH3401F24††	24	18.0	1	28.9/32.0	28.9/32.0	28.9/32.0	28.9/32.0	28.9/32.0	28.9/32.0	44.7/48.5	36.2/40.0	36.2/40.0	36.2/40.0	8/8	8/8	8/8	10/10	10/10	40/40	59/60	73/73	73/73	—	—	—	—	—	—	—	—	—	—	
KFCEH3501F30††	30	22.5	1	36.2/40.0	36.2/40.0	36.2/40.0	36.2/40.0	36.2/40.0	53.8/58.5	45.3/50.0	45.3/50.0	45.3/50.0	6/6	8/8	8/8	10/10	10/10	50/50	78/80	78/80	59/59	59/59	—	—	—	—	—	—	—	—	—	—	

- \* Includes blower motor amps of largest fan coil used with heater.
  - † Copper wire must be used. If other than uncoated (non-plated), 75°C ambient, copper wire (solid wire for 10 AWG and smaller, stranded wire for larger than 10 AWG) is used, consult applicable tables of the National Electric Code (ANSI/NFPA 70).
  - ‡ Length shown is as measured 1 way along wire path between unit and service panel for a voltage drop not to exceed 2%.
  - \*\* Field convertible to 3 phase.
  - †† Field convertible to 1 phase, single or multiple supply circuit.
- NOTES:**
1. For fan coil sizes 018-036.
  2. For fan coil sizes 042-060.
  3. Single circuit application of F15 and F20 heaters requires single-point wiring kit accessory.



## ACCESSORIES

	ITEM	ACCESSORY PART NO.*	FAN COIL SIZE USED WITH
1.	Disconnect Kit	KFADK0201DSC	Cooling controls and heaters 3– through 10–kW
2.	Downflow Base Kit	KFACB0201CFB	018, 024
		KFACB0301CFB	030, 036, 042
		KFACB0401CFB	048, 060
3.	Downflow Conversion Kit	KFADC0201SLP	Slope Coil Units—018, 024, 030, 036
		KFADC0401ACL	A–Coil Units—042, 048, 060
4.	Single–Point Wiring Kit	KFASP0101SPK	Only with 15– and 20–kW Fused Heaters
5.	Filter Kit (12 Pack)	KFAFK0212MED	018, 024
		KFAFK0312LRG	030, 036, 042
		KFAFK0412XXL	048, 060
6.	PVC Condensate Trap Kit (50 pack)	KFAET0150ETK	All
7.	Air Cleaner 240–volt Conversion Kit	KEAVC0201240	All
8.	Downflow Conversion Gasket Kit	KFAHD0101SLP	All
10.	TXV Kit Puron R–410A	KSATX0201PUR	018, 024, 030
		KSATX0301PUR	036, 042
		KSATX0401PUR	048, 060
11.	TXV Kit R–22	KSATX0601HSO	018, 024, 030, 036, 042
		KSATX0701HSO	048
		KSATX1001HSO	060

\* Factory authorized and listed, field–installed.

### Accessory Kits Description Suggested and Required Use.

**1. Disconnect Kit**

The kit is used to disconnect electrical power to the fan coil so service or maintenance may be performed safely.  
**SUGGESTED USE:** Units for 3- through 10-kW electric resistance heaters and cooling controls.

**2. Downflow Base Kit**

This kit is designed to provide a 1-in (25mm) minimum clearance between unit discharge plenum, ductwork, and combustible materials. It also provides a gap-free seal with the floor.  
**REQUIRED USE:** This kit must be used whenever fan coils are used in downflow applications.

**3. Downflow Conversion Kit**

Fan coils are shipped from the factory for upflow applications. Downflow conversion kits provide proper condensate water drainage and support for the coil when used in downflow applications. Separate kits are available for slope coils and A-coils.  
**REQUIRED USE:** This kit must be used whenever fan coils are used in downflow applications.

**4. Single Point Wiring Kit**

The single point wiring kit acts as a jumper between L1 and L3 lugs, and between the L2 and L4 lugs. This allows the installer to run two heavy-gauge, high-voltage wires into the fan coil rather than 4 light-gauge, high-voltage wires.  
**SUGGESTED USE:** Fan coils with 15- and 20-kW fused heaters only.

**5. Filter Kit (12 pack)**

The kit consists of 12 fan coil framed filters. These filters collect large dust particles from the return air entering the fan coil and prevents them from collecting on the coil. This process helps to keep the coil clean, which increases heat transfer and, in turn, the efficiency of the system.  
**SUGGESTED USE:** To replace filters in fan coils.  
**REQUIRED USE:** All units unless a filter grille is used.

**6. Condensate Drain Trap Kit**

This kit consists of 50 PVC condensate traps. Each trap is pre-formed and ready for field installation. This deep trap helps the system make and hold proper condensate flow even during blower initiation.  
**SUGGESTED USE:** All fan coils.

**7. Air Cleaner 240-volt Conversion Kit**

The AIRA electronic air cleaner comes ready for 115-v operation.  
**REQUIRED USE:** This kit is required when running 240-volt circuit to air cleaner.

**8. Downflow Conversion Gasket Kit**

This kit provides the proper gasketing of units when applied in a downflow application.  
**REQUIRED USE:** Fan coils in downflow applications.

FY5B