

RAS Series
RAS-09-22LKV-UL

**Engineering
Databook**



1:1 Inverter Single Split: RAS-09-22LKV-UL DATABOOK

Contents

1. Product lineup	1
2. Specifications	2
3. Dimensions of Indoor and outdoor units	3
4. Application data	
■ Part load performance	6
■ Sensible capacity tables	11
■ Refrigerant cycle diagram	14
■ Air throw chart	19
■ Indoor and outdoor sound characteristics	24
■ Wiring diagrams	34
■ Remote control	37

1

Product Lineup

Hi-Wall Type	Size	9	12	15	17	22
	Outdoor unit					
	Model name	RAS-09LAV-UL	RAS-12LAV-UL	RAS-15LAV-UL	RAS-17LAV-UL	RAS-22LAV-UL
	RAS-09LKV-UL	●	-	-	-	-
	RAS-12LKV-UL	-	●	-	-	-
	RAS-15LKV-UL	-	-	●	-	-
	RAS-17LKV-UL	-	-	-	●	-
	RAS-22LKV-UL	-	-	-	-	●

2

Specifications

		9	12	15	17	22	
System	Size		9	12	15	17	22
	Outdoor Model		RAS-09LKV-UL	RAS-12LKV-UL	RAS-15LKV-UL	RAS-17LKV-UL	RAS-22LKV-UL
	Indoor Model		RAS-09LAV-UL	RAS-12LAV-UL	RAS-15LAV-UL	RAS-17LAV-UL	RAS-22LAV-UL
Performance	Cooling Rated Capacity	Btu/h	9000	12000	15000	16200	21400
	Cooling Range Capacity		3750 - 10580	2750 - 13950	2750 - 17050	3750 - 20450	4100 - 22500
	EER	Btu/h.W	13.00	12.60	13.00	12.60	8.30
	SEER	Btu/h.W	20	23	20	19	15.5
	Heating Rated Capacity	Btu/h	10800	14200	18000	20200	23200
	Heating Range Capacity		3070 - 16350	3070 - 19000	3070 - 23500	2750 - 21500	3450 - 24350
	COP	Btu/h.W	13.50	13.00	12.80	12.40	10.50
	HSPF		10	9.7	9	9	9
Controls	Wireless (°C, °F, Convertible)		Yes	Yes	Yes	Yes	Yes
	R or RF		IR	IR	IR	IR	IR
Operating Range	Cooling						
	Outdoor Min - Max DB	°F	14~115	14~115	14~115	14~115	14~115
	Indoor Min - Max DB	°F	70~90	70~90	70~90	70~90	70~90
	Indoor Min - Max WB	°F	59~75.2	59~75.2	59~75.2	59~75.2	59~75.2
	Heating						
	Outdoor DB Min - Max	°F	5~75	5~75	5~75	5~75	5~75
	Indoor DB Min - Max	°F	Less than 82	Less than 82	Less than 82	Less than 82	Less than 82
Piping	Min. Piping Length	ft (m)	6.6 (2)	6.6 (2)	6.6 (2)	6.6 (2)	6.6 (2)
	Standard Piping Length	ft (m)	16 (5)	16 (5)	25 (7.5)	25 (7.5)	25 (7.5)
	Max. Piping Length with no additional refrigerant charge	ft (m)	50 (15)	50 (15)	50 (15)	50 (15)	50 (15)
	Max. Piping Length	ft (m)	66 (20)	66 (20)	66 (20)	66 (20)	66 (20)
	Additional refrigerant charge (between 50 - 66 ft./15 - 20 m)		0.22 oz/ft (20g/m)	0.22 oz/ft (20g/m)	0.22 oz/ft (20g/m)	0.22 oz/ft (20g/m)	0.22 oz/ft (20g/m)
	Gas Pipe (size/connection type)	in	3/8	3/8	1/2	1/2	1/2
	Liquid Pipe (size/connection type)	in	1/4	1/4	1/4	1/4	1/4
Electrical	Voltage	V-Ph-Hz	208/230-1-60	208/230-1-60	208/230-1-60	208/230-1-60	208/230-1-60
	Indoor Unit Connected from Outdoor (Yes/No)		Yes	Yes	Yes	Yes	Yes
	Number of Conductors Between Indoor and Outdoor Units		4	4	4	4	4
	Type of Wire (Shielded - yes or no)		No	No	No	No	No
	Cooling Power Consumption	W	690 (250 - 820)	950 (150 - 1250)	1150 (160 - 1720)	1285 (190 - 2010)	2570 (210 - 2720)
	Heating Power Consumption	W	800 (170 - 1400)	1090 (160 - 1580)	1400 (160 - 1990)	1630 (150 - 1910)	2200 (190 - 2440)
	Cooling Running Current	A	3.33 (1.36 - 3.75)	4.35 (0.93 - 5.66)	5.20 (0.94 - 7.60)	5.80 (1.12 - 8.90)	11.5 (1.25 - 12.10)
	Heating Running Current	A	3.74 (0.92 - 6.21)	4.99 (0.99 - 7.00)	6.30 (0.96 - 8.80)	7.30 (0.90 - 8.50)	9.9 (1.14 - 10.80)
	MCA	A	10	13	13	13	15
	MOPA	A	15	20	20	20	25
Outdoor	Dimensions						
	Height	in (mm)	21-11/16 (550)	21-11/16 (550)	21-11/16 (550)	21-11/16 (550)	21-11/16 (550)
	Width	in (mm)	30-11/16 (780)	30-11/16 (780)	30-11/16 (780)	30-11/16 (780)	30-11/16 (780)
	Length	in (mm)	11-7/16 (290)	11-7/16 (290)	11-7/16 (290)	11-7/16 (290)	11-7/16 (290)
	Weight -Gross/Net	lbs (kg)	82 (37)/75 (34)	95 (43)/88 (40)	98 (44)/91 (41)	98 (44)/91 (41)	100 (45)/93 (42)
	Refrigerant charged	lbs (kg)	1.77 (0.80)	2.43 (1.10)	3.09 (1.40)	3.09 (1.40)	3.09 (1.40)
	Variable Speed Outdoor Motor (Yes/No)		Yes	Yes	Yes	Yes	Yes
	Appearance		White	White	White	White	White
Compress	Sound Pressure (dBa)	dBa	47	50	51	52	53
	Type		DA89X1C-23FZ2	DA111A1F-20F2	DA130A1F-27F1	DA130A1F-27F1	DA150A1F-20F1
Indoor	Motor		DC-INVERTER	DC-INVERTER	DC-INVERTER	DC-INVERTER	DC-INVERTER
	Dimensions						
	Width	in (mm)	10-25/32 (275)	10-25/32 (275)	12-19/32 (320)	12-19/32 (320)	12-19/32 (320)
	Height	in (mm)	31-1/8 (790)	31-1/8 (790)	41-5/16 (1050)	41-5/16 (1050)	41-5/16 (1050)
	Length	in (mm)	8-1/16 (205)	8-1/16 (205)	8-15/16 (228)	8-15/16 (228)	8-15/16 (228)
	Weight -Gross/Net	lbs (kg)	25 (11)/20 (9)	25 (11)/20 (9)	35 (16)/29 (13)	35 (16)/29 (13)	35 (16)/29 (13)
	Appearance		White	White	White	White	White
	Sound Pressure at Different Speeds (cooling operation)	dBa	39/36/34/30/27	45/42/40/35/30	44/41/38/35/32	47/44/41/38/35	47/44/41/38/35
	Sound Pressure at Different Speeds (heating operation)	dBa	40/37/35/32/29	46/43/41/36/32	44/41/39/35/32	47/44/42/38/35	47/44/42/38/35
	Air flow (cooling operation)	CFM	303/274/244/211/177	406/355/304/262/219	562/504/445/396/346	636/571/505/447/388	636/571/505/447/388
Air flow (heating operation)	CFM	335/304/272/242/211	438/396/353/300/247	583/544/505/440/374	646/609/572/496/420	646/609/572/496/420	

3

Dimensions of Indoor and outdoor units

Indoor units:

RAS-09LKV-UL
RAS-12LKV-UL

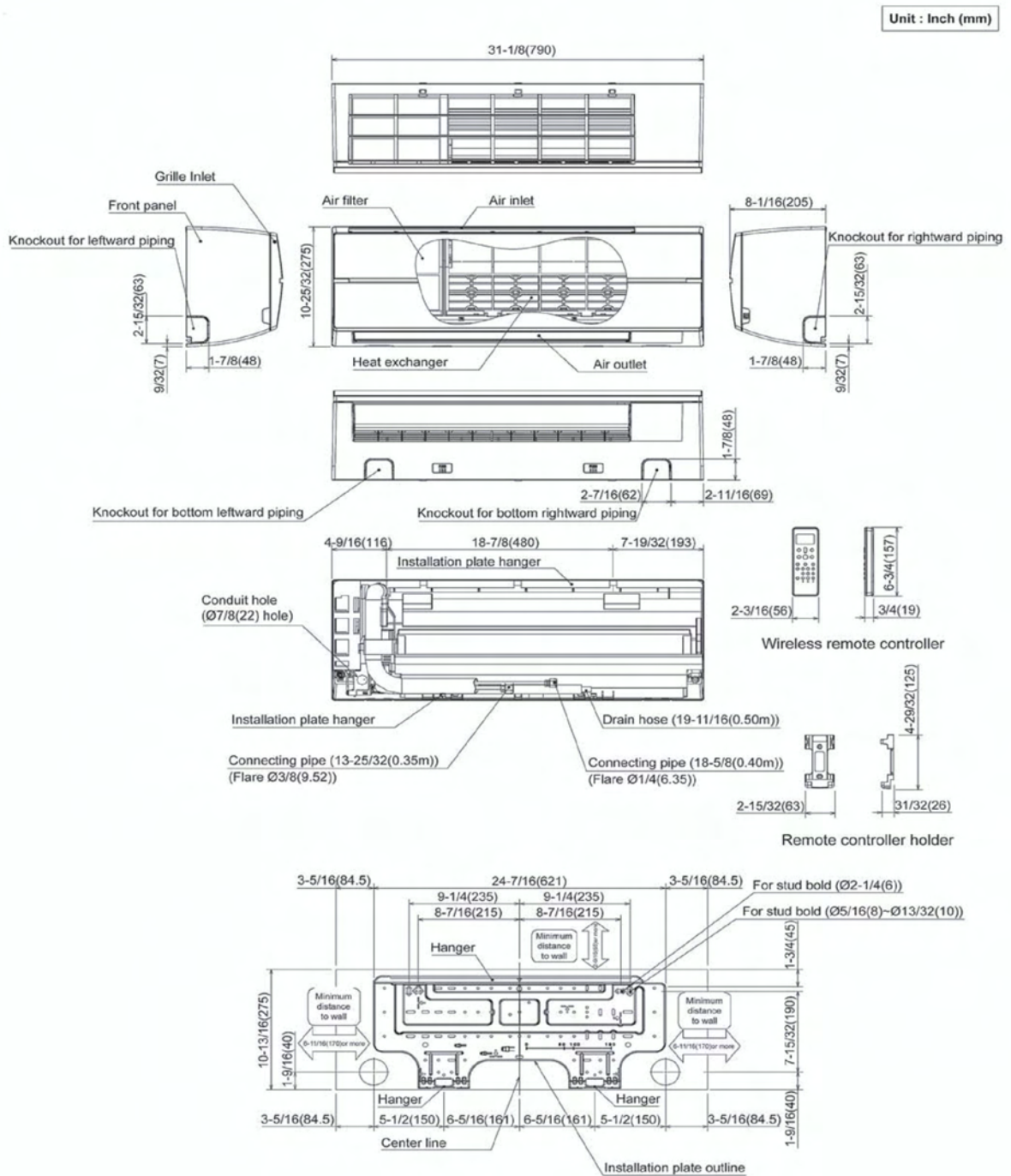

Indoor units:

RAS-15LKV-UL
RAS-17LKV-UL
RAS-22LKV-UL

Unit : Inch (mm)

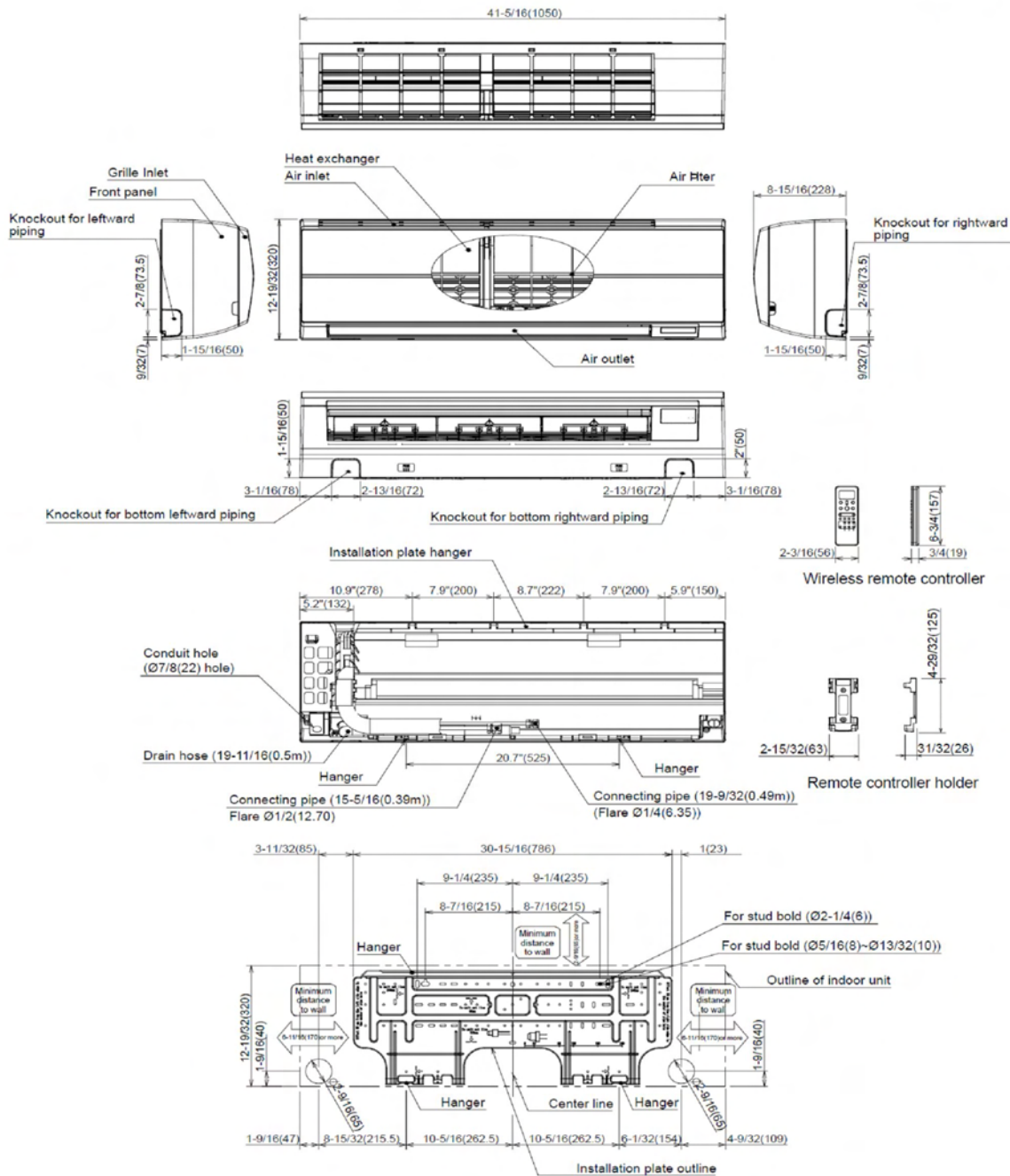

Outdoor units:

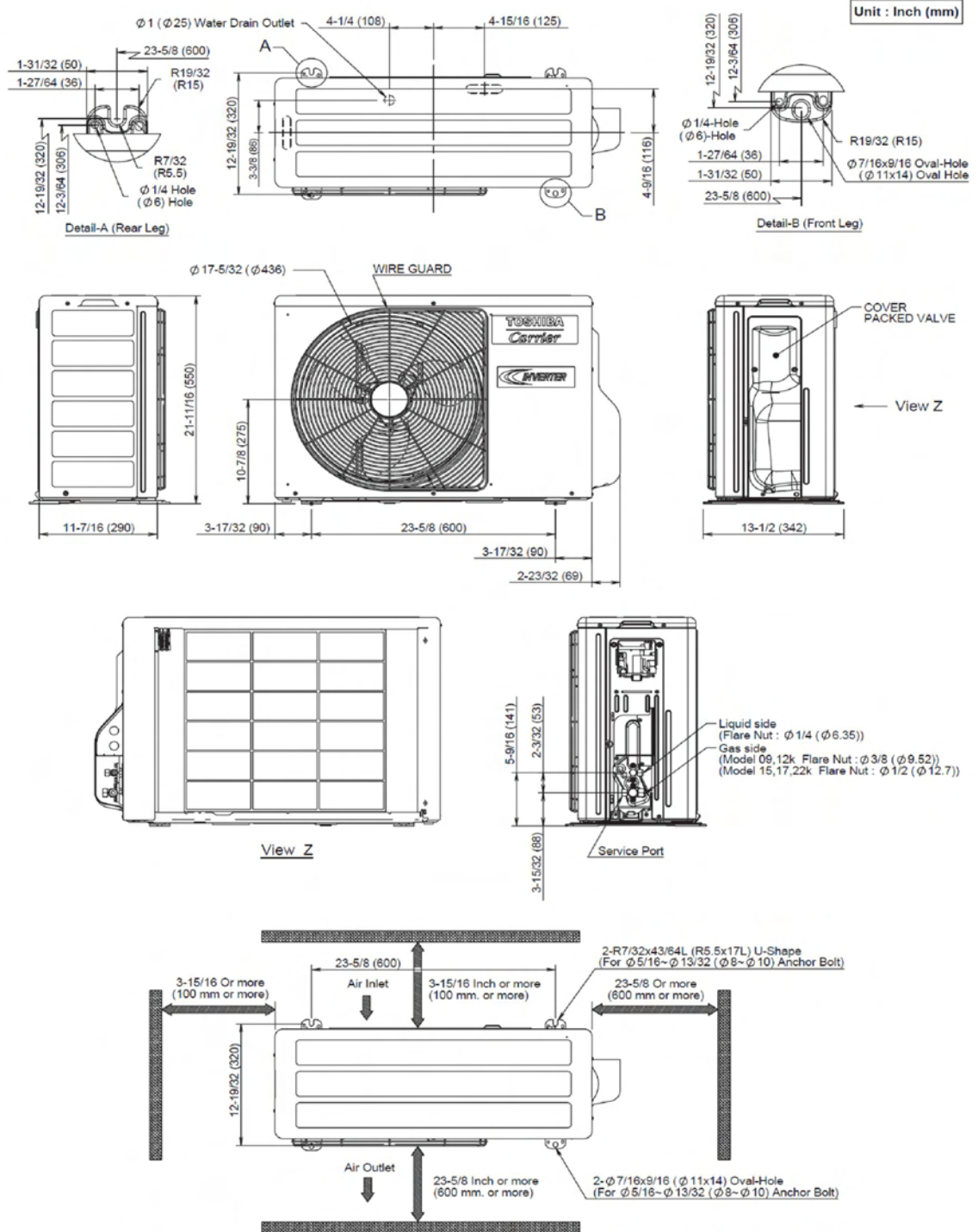

4

Application data

■ Part load performance

RAS-09LKV-UL/RAS-09LAV-UL

	Cooling		Heating	
	BTU	W	BTU	W
MINIMUM	3750	250	3070	170
RATING	9000	690	10800	800

Cooling

OD temp.		Load(%)									
		100	90	80	70	60	50	40	30	20	10
104	Q	8423	7581	6738	5896	5054	4212	3510	3510	3510	3510
	W	739	658	577	497	416	335	268	268	268	268
95	Q	9000	8100	7200	6300	5400	4500	3750	3750	3750	3750
	W	690	615	539	464	388	313	250	250	250	250
86	Q	9576	8618	7661	6703	5746	4788	3990	3990	3990	3990
	W	640	570	500	430	360	290	232	232	232	232
77	Q	10155	9140	8124	7109	6093	5078	4231	4231	4231	4231
	W	591	526	462	397	333	268	214	214	214	214
68	Q	10733	9660	8586	7513	6440	5367	4472	4472	4472	4472
	W	542	483	424	364	305	246	196	196	196	196

Heating

OD temp.		Load(%)									
		100	90	80	70	60	50	40	30	20	10
68	Q	14145	12731	11316	9902	8487	7073	5658	4244	4021	4021
	W	949	845	740	636	531	427	323	218	202	202
59	Q	12751	11476	10201	8926	7651	6376	5100	3825	3625	3625
	W	887	789	692	594	497	399	301	204	188	188
50	Q	11357	10221	9086	7950	6814	5679	4543	3407	3228	3228
	W	825	734	643	553	462	371	280	190	175	175
47	Q	10800	9720	8640	7560	6480	5400	4320	3240	3070	3070
	W	800	712	624	536	448	360	272	184	170	170
41	Q	8082	7274	6466	5657	4849	4041	3233	2425	2297	2297
	W	727	647	567	487	407	327	247	167	154	154
36	Q	7698	6928	6158	5389	4619	3849	3079	2309	2188	2188
	W	698	621	544	468	391	314	237	160	148	148
32	Q	7441	6697	5953	5209	4465	3721	2976	2232	2115	2115
	W	679	604	530	455	380	305	231	156	144	144
23	Q	6800	6120	5440	4760	4080	3400	2720	2040	1933	1933
	W	632	562	493	423	354	284	215	145	134	134
19	Q	6544	5890	5235	4581	3926	3272	2618	1963	1860	1860
	W	613	546	478	411	343	276	208	141	130	130
14	Q	5783	5205	4626	4048	3470	2892	2313	1735	1644	1644
	W	577	514	450	387	323	260	196	133	123	123
5	Q	4390	3951	3512	3073	2634	2195	1756	1317	1248	1248
	W	515	458	402	345	288	232	175	118	109	109

■ Part load performance

RAS-12LKV-UL/RAS-12LAV-UL

	Cooling		Heating	
	BTU	W	BTU	W
MINIMUM	2750	150	3070	160
RATING	12000	950	14200	1090

Cooling

OD temp.		Load(%)									
		100	90	80	70	60	50	40	30	20	10
104	Q	11230	10107	8984	7861	6738	5615	4492	3369	2574	2574
	W	1018	907	796	684	573	462	351	240	161	161
95	Q	12000	10800	9600	8400	7200	6000	4800	3600	2750	2750
	W	950	846	742	639	535	431	327	224	150	150
86	Q	12770	11493	10216	8939	7662	6385	5108	3831	2926	2926
	W	882	786	689	593	497	400	304	208	139	139
77	Q	13540	12186	10832	9478	8124	6770	5416	4062	3103	3103
	W	814	725	636	547	458	369	280	192	129	129
68	Q	14130	12717	11304	9891	8478	7065	5652	4239	3238	3238
	W	746	665	583	502	420	339	257	176	118	118

Heating

OD temp.		Load(%)									
		100	90	80	70	60	50	40	30	20	10
68	Q	18597	16737	14878	13018	11158	9299	7439	5579	4021	4021
	W	1293	1152	1012	871	730	589	449	308	190	190
59	Q	16765	15089	13412	11736	10059	8383	6706	5030	3625	3625
	W	1208	1077	945	814	682	551	419	288	177	177
50	Q	14933	13440	11946	10453	8960	7467	5973	4480	3228	3228
	W	1124	1002	879	757	635	512	390	268	165	165
47	Q	14200	12780	11360	9940	8520	7100	5680	4260	3070	3070
	W	1090	971	853	734	615	497	378	259	160	160
41	Q	10627	9564	8502	7439	6376	5314	4251	3188	2298	2298
	W	991	883	775	667	559	452	344	236	145	145
36	Q	12130	10917	9704	8491	7278	6065	4852	3639	2622	2622
	W	952	848	745	641	537	434	330	227	140	140
32	Q	9784	8806	7827	6849	5870	4892	3914	2935	2115	2115
	W	926	825	724	624	523	422	321	220	136	136
23	Q	8941	8047	7153	6259	5365	4471	3576	2682	1933	1933
	W	861	767	674	580	486	392	299	205	126	126
19	Q	8604	7744	6883	6023	5162	4302	3442	2581	1860	1860
	W	835	744	653	562	471	381	290	199	123	123
14	Q	7604	6844	6083	5323	4562	3802	3042	2281	1644	1644
	W	786	700	615	529	444	358	273	187	115	115
5	Q	5772	5194	4617	4040	3463	2886	2309	1731	1248	1248
	W	702	626	549	473	396	320	244	167	103	103

■ Part load performance

RAS-15LKV-UL/RAS-15LAV-UL

	Cooling		Heating	
	BTU	W	BTU	W
MINIMUM	2750	160	3070	160
RATING	15000	1150	18000	1400

Cooling

OD temp.		Load(%)									
		100	90	80	70	60	50	40	30	20	10
104	Q	14088	12679	11270	9862	8453	7044	5635	4226	2818	2583
	W	1232	1102	972	842	713	583	453	323	193	171
95	Q	15000	13500	12000	10500	9000	7500	6000	4500	3000	2750
	W	1150	1029	908	786	665	544	423	301	180	160
86	Q	15963	14367	12770	11174	9578	7982	6385	4789	3193	2927
	W	1068	955	843	730	618	505	393	280	167	149
77	Q	16925	15233	13540	11848	10155	8463	6770	5078	3385	3103
	W	985	881	777	674	570	466	362	258	154	137
68	Q	17888	16099	14310	12522	10733	8944	7155	5366	3578	3279
	W	903	808	713	617	522	427	332	237	141	126

Heating

OD temp.		Load(%)									
		100	90	80	70	60	50	40	30	20	10
68	Q	23574	21217	18859	16502	14144	11787	9430	7072	4715	4021
	W	1660	1483	1305	1128	951	774	596	419	242	190
59	Q	21252	19127	17002	14876	12751	10626	8501	6376	4250	3625
	W	1552	1386	1221	1055	889	723	558	392	226	177
50	Q	18929	17036	15143	13250	11357	9465	7572	5679	3786	3228
	W	1443	1289	1135	981	827	673	518	364	210	165
47	Q	18000	16200	14400	12600	10800	9000	7200	5400	3600	3070
	W	1400	1251	1101	952	802	653	503	354	204	160
41	Q	13471	12124	10777	9430	8083	6736	5388	4041	2694	2298
	W	1272	1136	1000	865	729	593	457	321	185	145
36	Q	12830	11547	10264	8981	7698	6415	5132	3849	2566	2188
	W	1222	1092	961	831	700	570	439	309	178	140
32	Q	12402	11162	9922	8681	7441	6201	4961	3721	2480	2115
	W	1189	1062	935	808	681	554	427	300	173	136
23	Q	11334	10201	9067	7934	6800	5667	4534	3400	2267	1933
	W	1106	988	870	752	634	515	397	279	161	126
19	Q	10907	9816	8726	7635	6544	5454	4363	3272	2181	1860
	W	1072	958	843	729	614	500	385	271	156	123
14	Q	9639	8675	7711	6747	5783	4820	3856	2892	1928	1644
	W	1010	902	794	686	579	471	363	255	147	115
5	Q	7316	6584	5853	5121	4390	3658	2926	2195	1463	1248
	W	901	805	709	612	516	420	324	228	131	103

■ Part load performance

RAS-17LKV-UL/RAS-17LAV-UL

	Cooling		Heating	
	BTU	W	BTU	W
MINIMUM	3750	190	2750	150
RATING	16200	1285	20200	1630

Cooling

OD temp.		Load(%)									
		100	90	80	70	60	50	40	30	20	10
104	Q	15161	13645	12129	10613	9097	7581	6064	4548	3509	3509
	W	1377	1224	1072	919	766	614	461	308	204	204
95	Q	16200	14580	12960	11340	9720	8100	6480	4860	3750	3750
	W	1285	1143	1000	858	715	573	430	288	190	190
86	Q	17240	15516	13792	12068	10344	8620	6896	5172	3991	3991
	W	1193	1061	928	796	664	532	399	267	176	176
77	Q	18279	16451	14623	12795	10967	9140	7312	5484	4231	4231
	W	1101	979	857	735	613	491	369	246	163	163
68	Q	19319	17387	15455	13523	11591	9660	7728	5796	4472	4472
	W	1009	897	785	673	561	450	338	226	149	149

Heating

OD temp.		Load(%)									
		100	90	80	70	60	50	40	30	20	10
68	Q	26455	23810	21164	18519	15873	13228	10582	7937	5291	3602
	W	1933	1730	1527	1323	1120	917	714	511	308	178
59	Q	23849	21464	19079	16694	14309	11925	9540	7155	4770	3247
	W	1807	1617	1427	1237	1047	857	667	478	288	166
50	Q	21243	19119	16994	14870	12746	10622	8497	6373	4249	2892
	W	1680	1503	1327	1150	974	797	621	444	267	155
47	Q	20200	18180	16160	14140	12120	10100	8080	6060	4040	2750
	W	1630	1459	1287	1116	945	773	602	431	259	150
41	Q	15117	13605	12094	10582	9070	7559	6047	4535	3023	2058
	W	1481	1325	1170	1014	858	703	547	391	236	136
36	Q	14398	12958	11518	10079	8639	7199	5759	4319	2880	1960
	W	1423	1273	1124	974	825	675	526	376	226	131
32	Q	13918	12526	11134	9743	8351	6959	5567	4175	2784	1895
	W	1384	1239	1093	948	802	657	511	366	220	127
23	Q	12719	11447	10175	8903	7631	6360	5088	3816	2544	1732
	W	1287	1152	1016	881	746	611	475	340	205	118
19	Q	12240	11016	9792	8568	7344	6120	4896	3672	2448	1666
	W	1248	1117	986	854	723	592	461	330	199	115
14	Q	10817	9735	8654	7572	6490	5409	4327	3245	2163	1473
	W	1176	1052	929	805	682	558	434	311	187	108
5	Q	8210	7389	6568	5747	4926	4105	3284	2463	1642	1118
	W	1050	940	829	719	609	498	388	277	167	97

■ Part load performance

RAS-22LKV-UL/RAS-22LAV-UL

	Cooling		Heating	
	BTU	W	BTU	W
MINIMUM	4100	210	3450	190
RATING	21400	2570	23200	2200

Cooling

OD temp.		Load(%)									
		100	90	80	70	60	50	40	30	20	10
104	Q	17028	15325	13622	11920	10217	8514	6811	5108	3406	3262
	W	2345	2079	1812	1546	1280	1013	747	480	214	192
95	Q	21400	19260	17120	14980	12840	10700	8560	6420	4280	4100
	W	2570	2278	1986	1694	1402	1110	818	526	235	210
86	Q	22773	20496	18218	15941	13664	11387	9109	6832	4555	4363
	W	2386	2115	1844	1573	1302	1031	760	489	218	195
77	Q	24146	21731	19317	16902	14488	12073	9658	7244	4829	4626
	W	2202	1952	1702	1452	1201	951	701	451	201	180
68	Q	25520	22968	20416	17864	15312	12760	10208	7656	5104	4889
	W	2017	1788	1559	1330	1101	871	642	413	184	165

Heating

OD temp.		Load(%)									
		100	90	80	70	60	50	40	30	20	10
68	Q	30385	27347	24308	21270	18231	15193	12154	9116	6077	4518
	W	2609	2329	2049	1769	1489	1209	929	649	369	225
59	Q	27391	24652	21913	19174	16435	13696	10956	8217	5478	4073
	W	2438	2176	1915	1653	1391	1130	868	606	345	211
50	Q	24397	21957	19518	17078	14638	12199	9759	7319	4879	3628
	W	2268	2025	1781	1538	1294	1051	808	564	321	196
47	Q	23200	20880	18560	16240	13920	11600	9280	6960	4640	3450
	W	2200	1964	1728	1492	1256	1019	783	547	311	190
41	Q	17362	15626	13890	12153	10417	8681	6945	5209	3472	2582
	W	1999	1784	1570	1355	1141	926	712	497	283	173
36	Q	16536	14882	13229	11575	9922	8268	6614	4961	3307	2459
	W	1921	1715	1509	1302	1096	890	684	478	272	166
32	Q	15985	14387	12788	11190	9591	7993	6394	4796	3197	2377
	W	1868	1668	1467	1267	1066	866	665	465	264	161
23	Q	14608	13147	11686	10226	8765	7304	5843	4382	2922	2172
	W	1737	1551	1364	1178	991	805	618	432	246	150
19	Q	14058	12652	11246	9841	8435	7029	5623	4217	2812	2091
	W	1685	1504	1323	1142	962	781	600	419	238	146
14	Q	12423	11181	9938	8696	7454	6212	4969	3727	2485	1847
	W	1587	1417	1246	1076	906	735	565	395	224	137
5	Q	9430	8487	7544	6601	5658	4715	3772	2829	1886	1402
	W	1417	1265	1113	961	809	657	505	352	200	122

■ Sensible capacity tables

Trend of Total & Sensible Heat Capacity / Indoor Air & Outdoor Air temperature.

Product models : RAS-09LKV-UL/RAS-09LAV-UL

Specification of product at standard condition.

Standard Condition	Indoor	80.0 °F DB / 67.0 °F WB
	Outdoor	95.0 °F DB / 75.0 °F WB

Total Cooling Capacity (TC)	9000	Btu/h
Sensible Heat Capacity (SHC)	7164	Btu/h

Outdoor air temp. °F Db	Indoor Air temperature													
	68 °F DB 57 °F WB		73 °F DB 61 °F WB		79 °F DB 64 °F WB		80 °F DB 67 °F WB		82 °F DB 68 °F WB		86 °F DB 72 °F WB		90 °F DB 75 °F WB	
	TC	SHC	TC	SHC	TC	SHC	TC	SHC	TC	SHC	TC	SHC	TC	SHC
68	8816	7553	9735	8051	10426	8559	10733	8543	11039	8537	11691	8455	12228	8289
70	8721	7472	9631	7965	10313	8467	10617	8451	10921	8445	11565	8364	12096	8200
73	8531	7309	9421	7791	10089	8283	10386	8267	10683	8261	11313	8182	11833	8021
77	8341	7147	9212	7618	9865	8099	10155	8083	10445	8077	11062	8000	11570	7843
81	8152	6984	9002	7445	9640	7915	9924	7900	10208	7894	10810	7818	11306	7665
84	7962	6822	8793	7271	9416	7730	9693	7716	9970	7710	10559	7636	11043	7486
88	7772	6659	8583	7098	9191	7546	9462	7532	9733	7526	10307	7454	10780	7308
91	7582	6497	8373	6925	8967	7362	9231	7348	9495	7342	10055	7272	10517	7129
95	7393	6334	8164	6752	8743	7178	9000	7164	9257	7159	9804	7090	10254	6951
99	7203	6171	7954	6578	8518	6993	8769	6980	9020	6975	9552	6908	9991	6773
102	7013	6009	7745	6405	8294	6809	8538	6796	8782	6791	9300	6726	9727	6594
106	6823	5846	7535	6232	8069	6625	8307	6612	8545	6608	9049	6544	9464	6416
109	6634	5684	7326	6058	7845	6441	8076	6428	8307	6424	8797	6362	9201	6237
111	6539	5602	7221	5972	7733	6349	7961	6337	8188	6332	8671	6271	9069	6148
113	6444	5521	7116	5885	7621	6257	7845	6245	8069	6240	8546	6180	8938	6059
115	6349	5440	7011	5798	7508	6164	7730	6153	7951	6148	8420	6089	8806	5970

Trend of Total & Sensible Heat Capacity / Indoor Air & Outdoor Air temperature.

Product models : RAS-12LKV-UL/RAS-12LAV-UL

Specification of product at standard condition.

Standard Condition	Indoor	80.0 °F DB / 67.0 °F WB
	Outdoor	95.0 °F DB / 75.0 °F WB

Total Cooling Capacity (TC)	10800	Btu/h
Sensible Heat Capacity (SHC)	8294	Btu/h

Outdoor air temp. °F Db	Indoor Air temperature													
	68 °F DB 57 °F WB		73 °F DB 61 °F WB		79 °F DB 64 °F WB		80 °F DB 67 °F WB		82 °F DB 68 °F WB		86 °F DB 72 °F WB		90 °F DB 75 °F WB	
	TC	SHC	TC	SHC	TC	SHC	TC	SHC	TC	SHC	TC	SHC	TC	SHC
68	10579	8768	11683	9334	12511	9921	12879	9891	13247	9873	14029	9753	14673	9536
70	10465	8673	11557	9234	12376	9814	12740	9785	13105	9767	13878	9648	14515	9433
73	10237	8485	11305	9033	12107	9601	12463	9572	12820	9554	13576	9438	14199	9228
77	10010	8296	11054	8832	11837	9387	12186	9359	12535	9342	13274	9228	13884	9023
81	9782	8107	10802	8631	11568	9174	11909	9146	12249	9129	12972	9018	13568	8818
84	9554	7919	10551	8430	11299	8960	11632	8933	11964	8917	12670	8808	13252	8612
88	9327	7730	10300	8229	11030	8747	11354	8720	11679	8704	12368	8598	12936	8407
91	9099	7541	10048	8028	10760	8533	11077	8507	11394	8492	12066	8389	12620	8202
95	8871	7352	9797	7828	10491	8319	10800	8294	11109	8279	11764	8179	12304	7997
99	8643	7164	9545	7627	10222	8106	10523	8082	10824	8067	11462	7969	11989	7791
102	8416	6975	9294	7426	9953	7892	10246	7869	10539	7854	11161	7759	11673	7586
106	8188	6786	9042	7225	9683	7679	9968	7656	10253	7642	10859	7549	11357	7381
109	7960	6598	8791	7024	9414	7465	9691	7443	9968	7429	10557	7339	11041	7176
111	7847	6503	8665	6923	9279	7359	9553	7336	9826	7323	10406	7234	10883	7073
113	7733	6409	8539	6823	9145	7252	9414	7230	9683	7217	10255	7129	10725	6970
115	7619	6314	8414	6723	9010	7145	9275	7124	9541	7111	10104	7024	10567	6868

■ Sensible capacity tables

Trend of Total & Sensible Heat Capacity / Indoor Air & Outdoor Air temperature.

Product models : RAS-15LKV-UL/RAS-15LAV-UL

Specification of product at standard condition.

Standard Condition	Indoor	80.0 °F DB / 67.0 °F WB
	Outdoor	95.0 °F DB / 75.0 °F WB

Total Cooling Capacity (TC)	15000	Btu/h
Sensible Heat Capacity (SHC)	12510	Btu/h

Outdoor air temp. °F DB	Indoor Air temperature													
	68 °F DB 57 °F WB		73 °F DB 61 °F WB		79 °F DB 64 °F WB		80 °F DB 67 °F WB		82 °F DB 68 °F WB		86 °F DB 72 °F WB		90 °F DB 75 °F WB	
	TC	SHC	TC	SHC	TC	SHC	TC	SHC	TC	SHC	TC	SHC	TC	SHC
68	14693	13147	16226	14035	17376	14926	17888	14918	18399	14927	19485	14832	20379	14589
70	14535	13006	16051	13884	17189	14765	17695	14758	18201	14767	19275	14672	20160	14432
73	14218	12723	15702	13582	16815	14444	17310	14437	17805	14445	18856	14353	19721	14118
77	13902	12440	15353	13280	16441	14123	16925	14115	17409	14124	18436	14034	19283	13804
81	13586	12157	15003	12978	16067	13802	16540	13794	17013	13803	18017	13715	18844	13490
84	13270	11874	14654	12676	15693	13480	16155	13473	16617	13481	17598	13395	18405	13176
88	12953	11591	14305	12374	15319	13159	15770	13152	16221	13160	17178	13076	17967	12862
91	12637	11308	13956	12072	14945	12838	15385	12831	15825	12839	16759	12757	17528	12548
95	12321	11025	13607	11770	14571	12516	15000	12510	15429	12518	16340	12438	17090	12234
99	12005	10742	13257	11468	14197	12195	14615	12189	15033	12196	15920	12118	16651	11920
102	11689	10459	12908	11165	13823	11874	14230	11868	14637	11875	15501	11799	16212	11606
106	11372	10176	12559	10863	13449	11553	13845	11547	14241	11554	15081	11480	15774	11292
109	11056	9893	12210	10561	13075	11231	13460	11226	13845	11232	14662	11161	15335	10978
111	10898	9751	12035	10410	12888	11071	13268	11065	13647	11072	14452	11001	15116	10821
113	10740	9610	11860	10259	12701	10910	13075	10905	13449	10911	14243	10841	14896	10664
115	10582	9468	11686	10108	12514	10750	12883	10744	13251	10750	14033	10682	14677	10507

Trend of Total & Sensible Heat Capacity / Indoor Air & Outdoor Air temperature.

Product models : RAS-17LKV-UL/RAS-17LAV-UL

Specification of product at standard condition.

Standard Condition	Indoor	80.0 °F DB / 67.0 °F WB
	Outdoor	95.0 °F DB / 75.0 °F WB

Total Cooling Capacity (TC)	16200	Btu/h
Sensible Heat Capacity (SHC)	13580	Btu/h

Outdoor air temp. °F DB	Indoor Air temperature													
	68 °F DB 57 °F WB		73 °F DB 61 °F WB		79 °F DB 64 °F WB		80 °F DB 67 °F WB		82 °F DB 68 °F WB		86 °F DB 72 °F WB		90 °F DB 75 °F WB	
	TC	SHC	TC	SHC	TC	SHC	TC	SHC	TC	SHC	TC	SHC	TC	SHC
68	15868	14267	17524	15233	18766	16200	19319	16194	19871	16206	21044	16108	22010	15851
70	15697	14113	17335	15069	18564	16026	19111	16020	19657	16032	20817	15935	21773	15680
73	15356	13806	16958	14741	18160	15677	18695	15671	19229	15683	20364	15588	21299	15339
77	15014	13499	16581	14413	17756	15328	18279	15323	18802	15334	19911	15242	20825	14998
81	14673	13192	16204	14085	17352	14980	17863	14974	18374	14985	19458	14895	20352	14657
84	14331	12885	15827	13758	16948	14631	17447	14626	17946	14637	19005	14548	19878	14315
88	13990	12578	15449	13430	16544	14282	17032	14277	17519	14288	18553	14201	19404	13974
91	13648	12271	15072	13102	16141	13934	16616	13929	17091	13939	18100	13855	18930	13633
95	13307	11964	14695	12774	15737	13585	16200	13580	16663	13590	17647	13508	18457	13292
99	12965	11657	14318	12446	15333	13236	15784	13231	16236	13241	17194	13161	17983	12951
102	12624	11350	13941	12118	14929	12888	15368	12883	15808	12893	16741	12815	17509	12610
106	12282	11042	13564	11790	14525	12539	14953	12534	15380	12544	16288	12468	17035	12268
109	11941	10735	13186	11463	14121	12190	14537	12186	14953	12195	15835	12121	16562	11927
111	11770	10582	12998	11299	13919	12016	14329	12012	14739	12020	15608	11948	16325	11757
113	11599	10428	12809	11135	13717	11842	14121	11837	14525	11846	15382	11774	16088	11586
115	11428	10275	12621	10971	13515	11667	13913	11663	14311	11672	15156	11601	15851	11416

■ Sensible capacity tables

Trend of Total & Sensible Heat Capacity / Indoor Air & Outdoor Air temperature.

Product models : RAS-22LKV-UL/RAS-22LAV-UL

Specification of product at standard condition.

Standard Condition	Indoor	80.0 °F DB / 67.0 °F WB
	Outdoor	95.0 °F DB / 75.0 °F WB

Total Cooling Capacity (TC)	21400	Btu/h
Sensible Heat Capacity (SHC)	15800	Btu/h

Outdoor air temp. °F DB	Indoor Air temperature													
	68 °F DB 57 °F WB		73 °F DB 61 °F WB		79 °F DB 64 °F WB		80 °F DB 67 °F WB		82 °F DB 68 °F WB		86 °F DB 72 °F WB		90 °F DB 75 °F WB	
	TC	SHC	TC	SHC	TC	SHC	TC	SHC	TC	SHC	TC	SHC	TC	SHC
68	20962	16751	23149	17809	24790	18922	25520	18842	26249	18785	27798	18500	29074	18032
70	20736	16571	22900	17617	24523	18719	25245	18639	25967	18582	27499	18301	28761	17838
73	20285	16210	22401	17234	23989	18311	24696	18233	25402	18178	26901	17903	28136	17450
77	19834	15850	21903	16850	23456	17904	24146	17828	24837	17774	26303	17505	27510	17062
81	19383	15489	21405	16467	22922	17497	23597	17422	24272	17369	25704	17107	26884	16674
84	18931	15128	20907	16084	22389	17090	23048	17017	23707	16965	25106	16708	26258	16286
88	18480	14768	20408	15701	21855	16682	22499	16611	23142	16561	24508	16310	25633	15898
91	18029	14407	19910	15317	21322	16275	21949	16206	22577	16157	23909	15912	25007	15510
95	17578	14047	19412	14934	20788	15868	21400	15800	22012	15752	23311	15514	24381	15122
99	17127	13686	18914	14551	20254	15461	20851	15394	21447	15348	22713	15116	23755	14733
102	16676	13326	18415	14167	19721	15053	20301	14989	20882	14944	22114	14718	23129	14345
106	16224	12965	17917	13784	19187	14646	19752	14583	20317	14539	21516	14319	22504	13957
109	15773	12605	17419	13401	18654	14239	19203	14178	19752	14135	20918	13921	21878	13569
111	15548	12424	17170	13209	18387	14035	18928	13975	19470	13933	20619	13722	21565	13375
113	15322	12244	16921	13017	18120	13831	18654	13772	19187	13731	20319	13523	21252	13181
115	15097	12064	16672	12826	17853	13628	18379	13570	18905	13529	20020	13324	20939	12987

■ Refrigerant cycle diagram

RAS-09LKV-UL/RAS-09LAV-UL

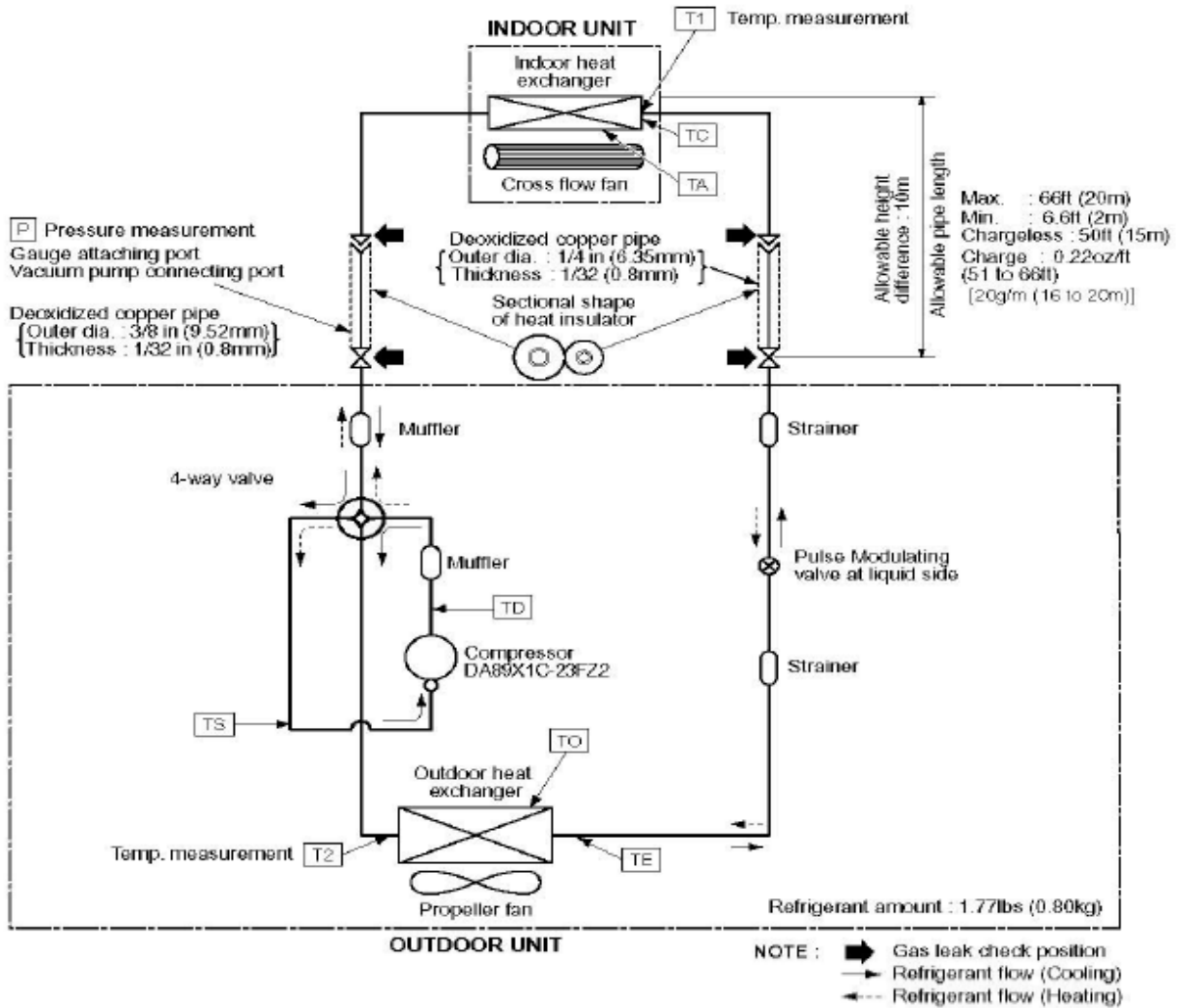

■ Refrigerant cycle diagram

RAS-12LKV-UL/RAS-12LAV-UL

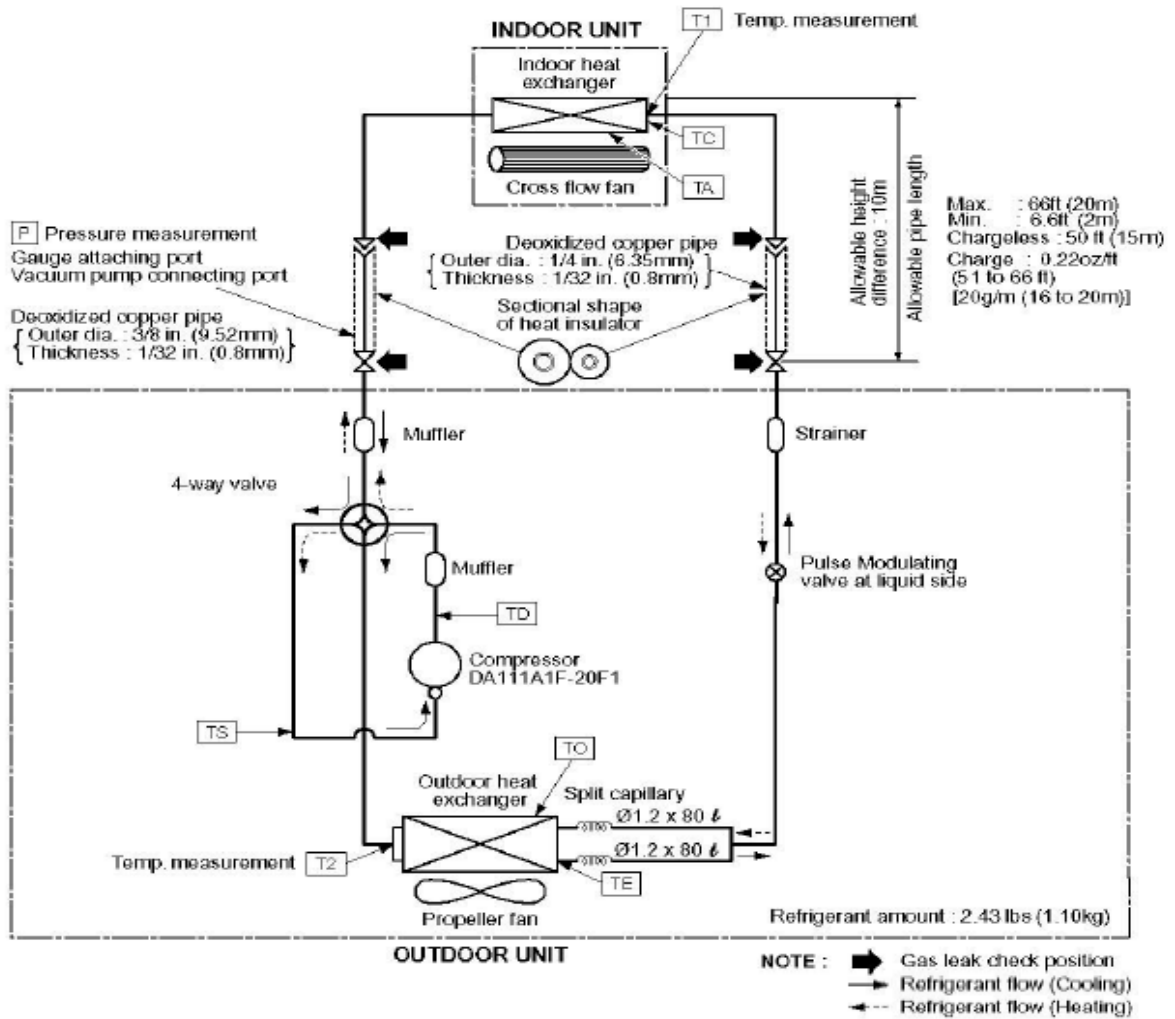

■ Refrigerant cycle diagram

RAS-15LKV-UL/RAS-15LAV-UL

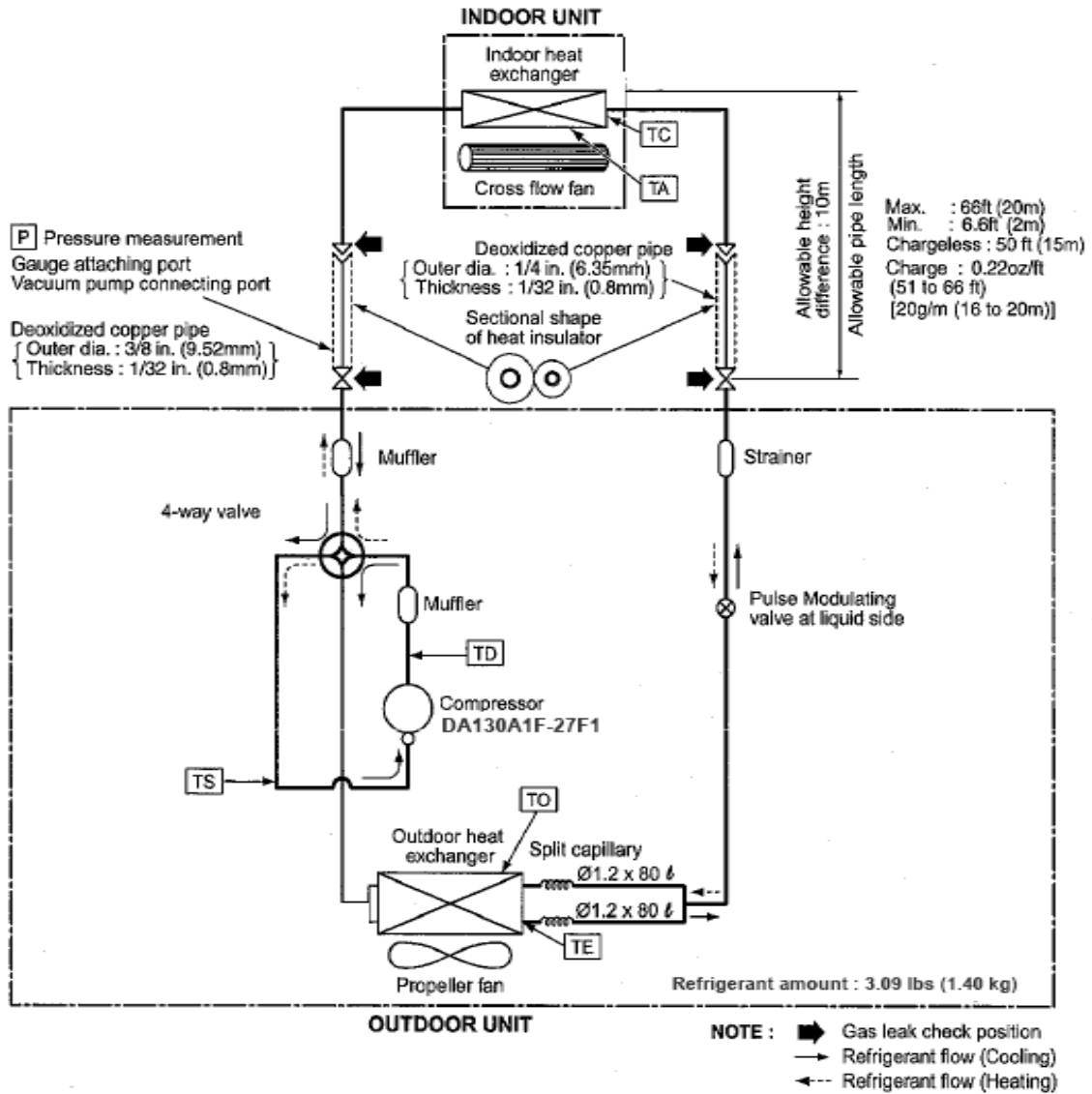

■ Refrigerant cycle diagram

RAS-17LKV-UL/RAS-17LAV-UL

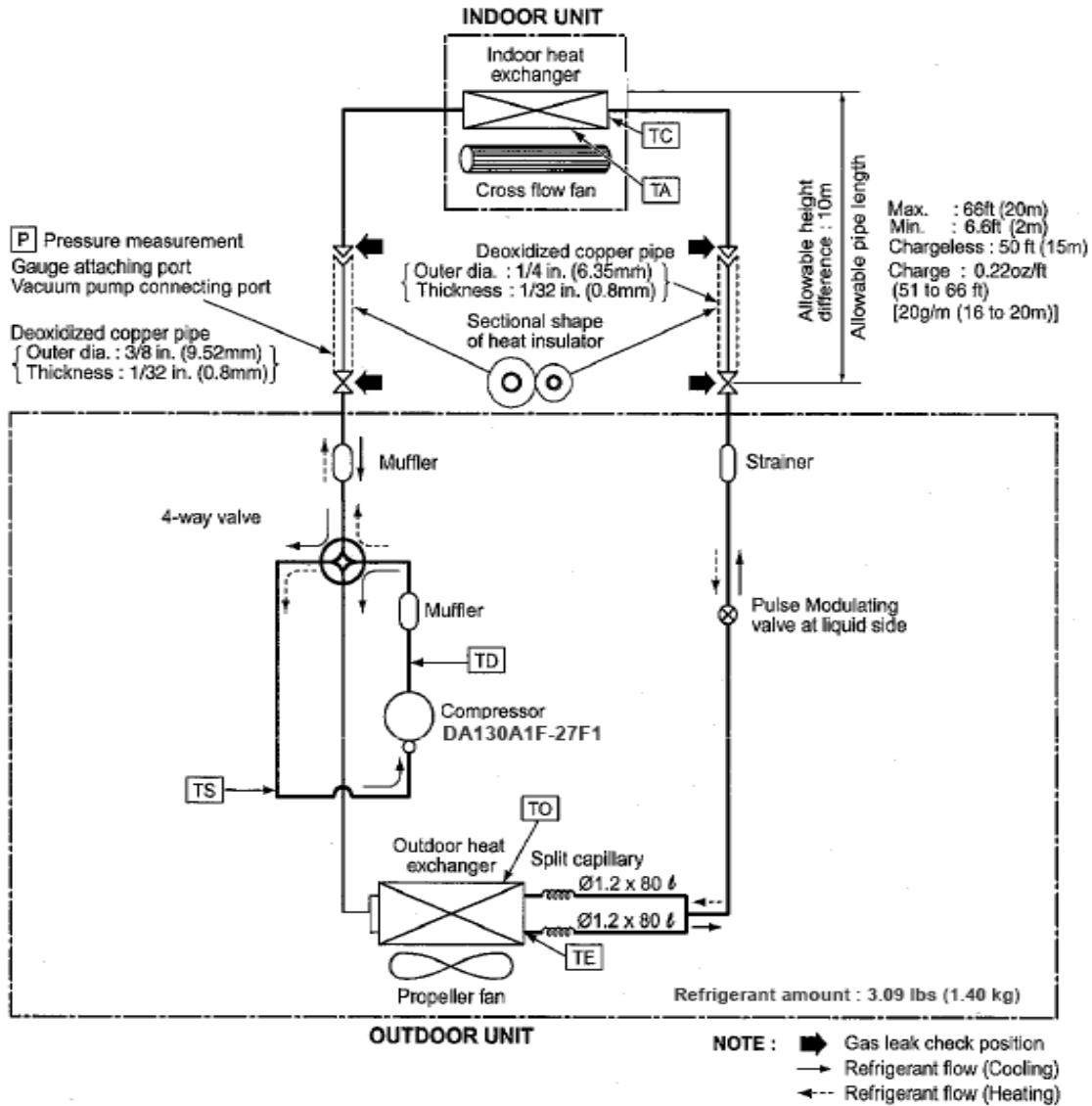

■ Refrigerant cycle diagram

RAS-22LKV-UL/RAS-22LAV-UL

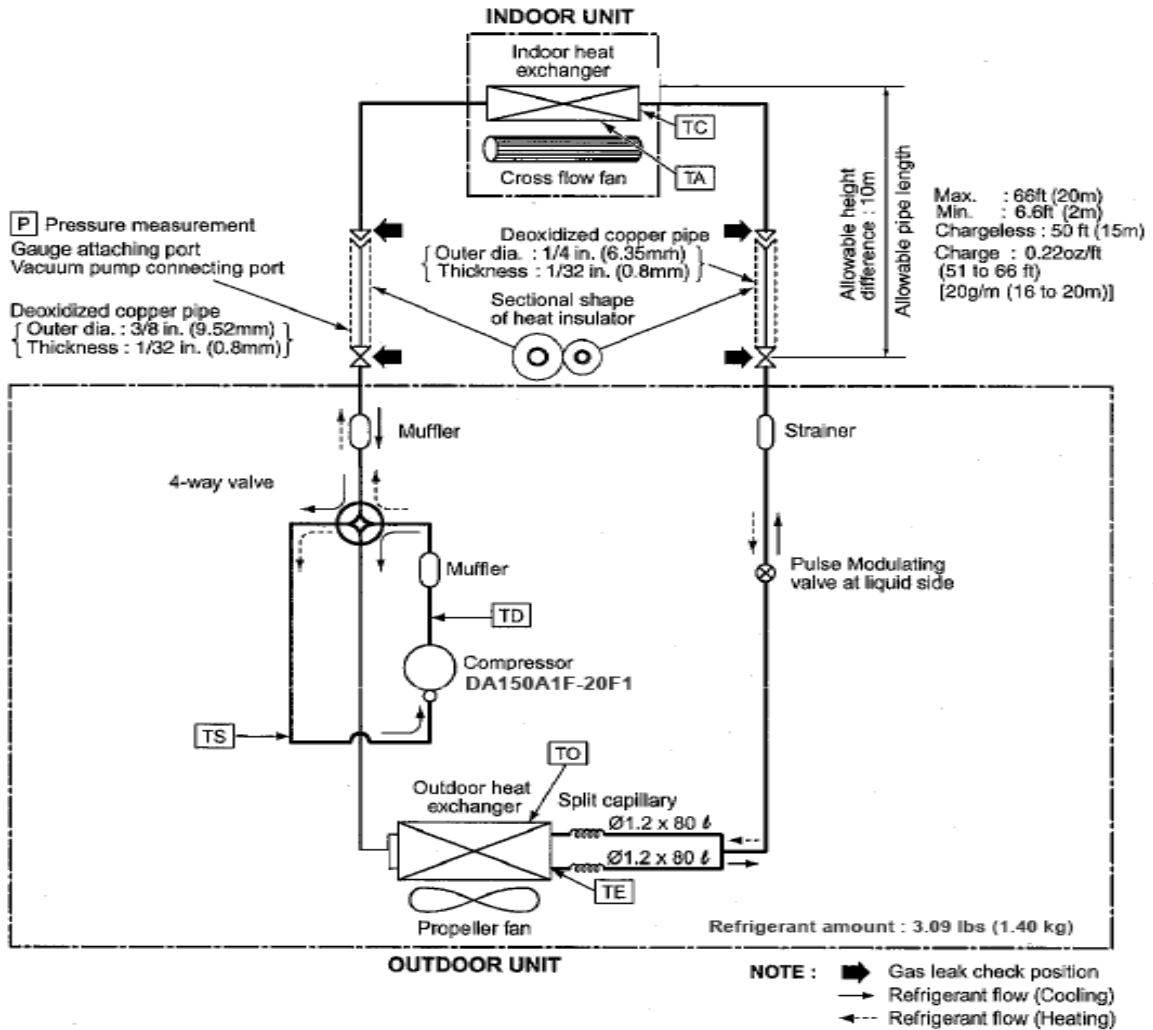

Air throw chart

Cooling

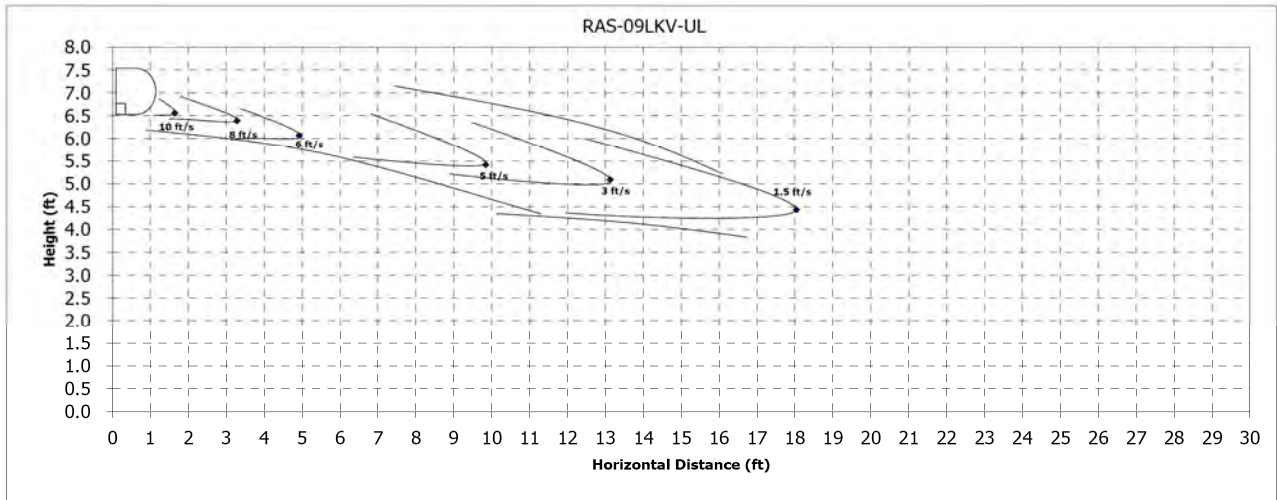

Heating

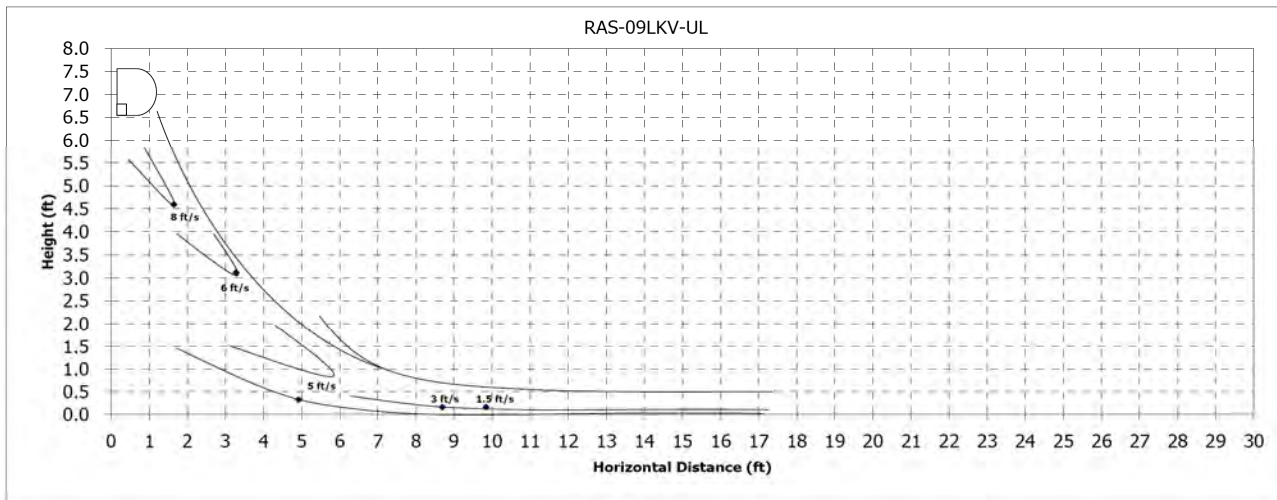

Air throw chart

Cooling

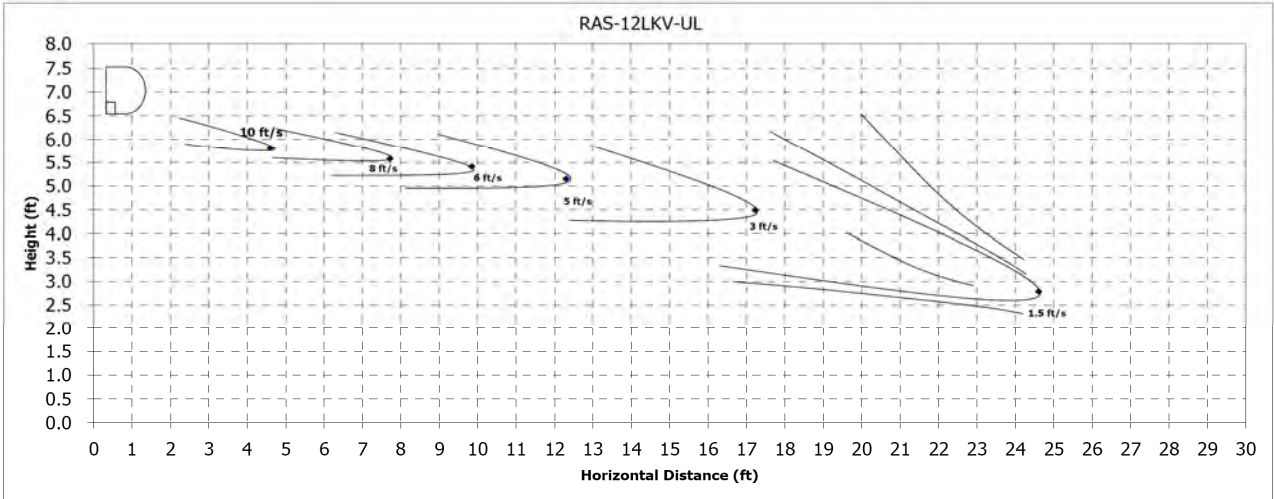

Heating

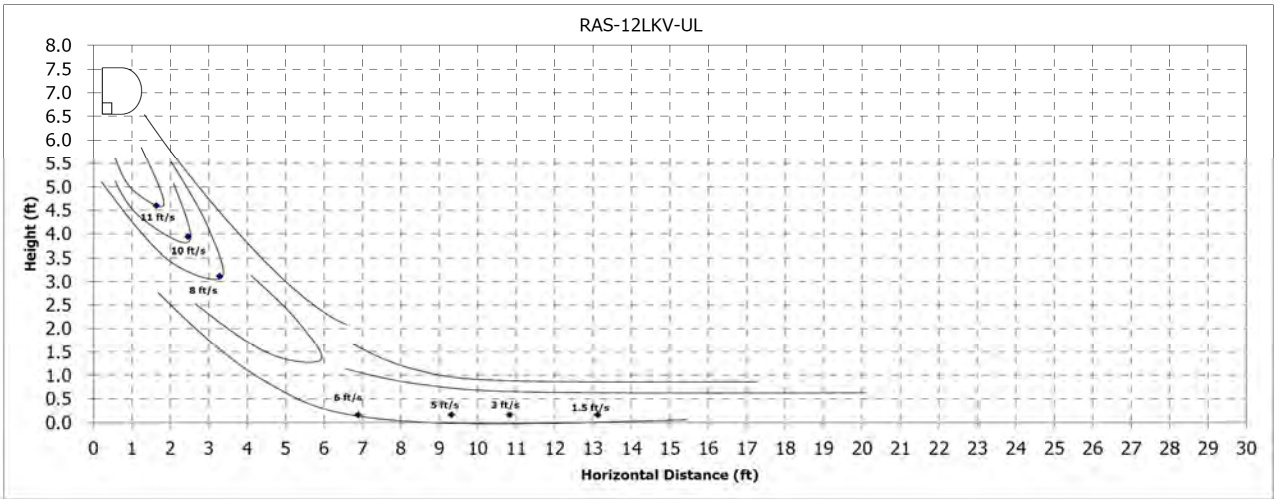

Air throw chart

Cooling

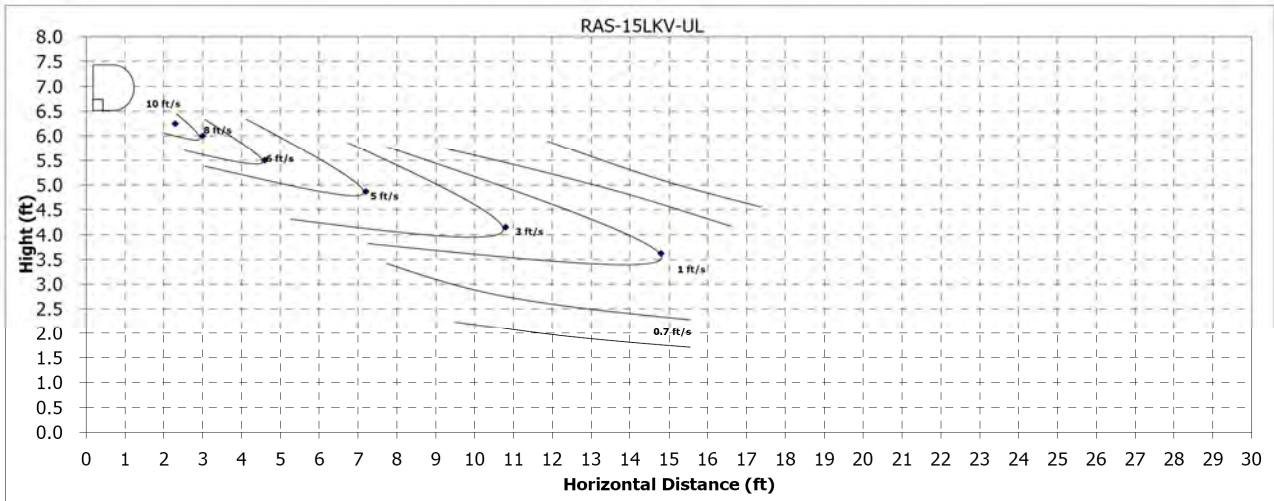

Heating

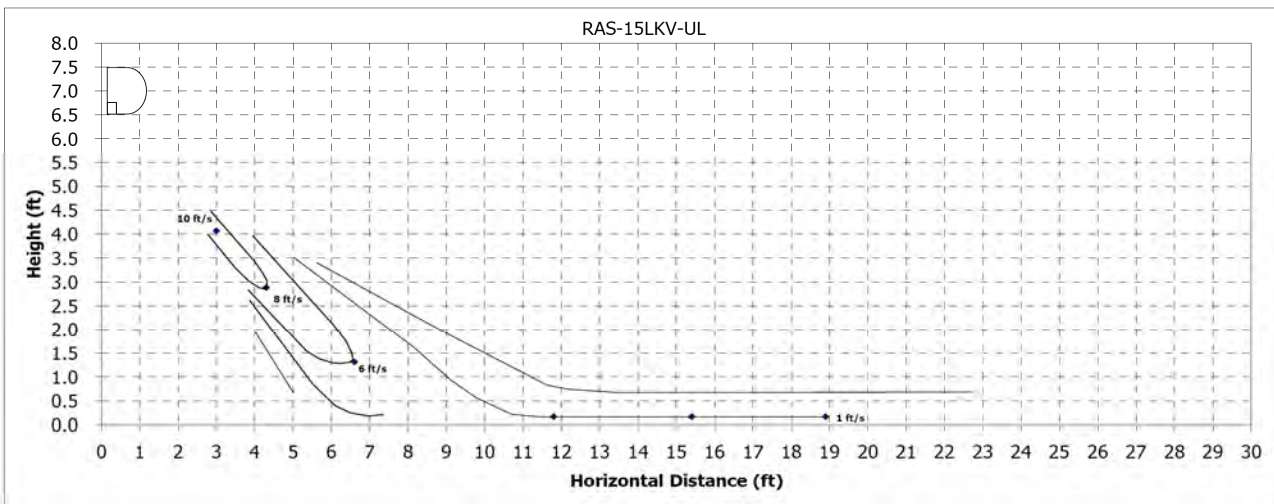

Air throw chart

Cooling

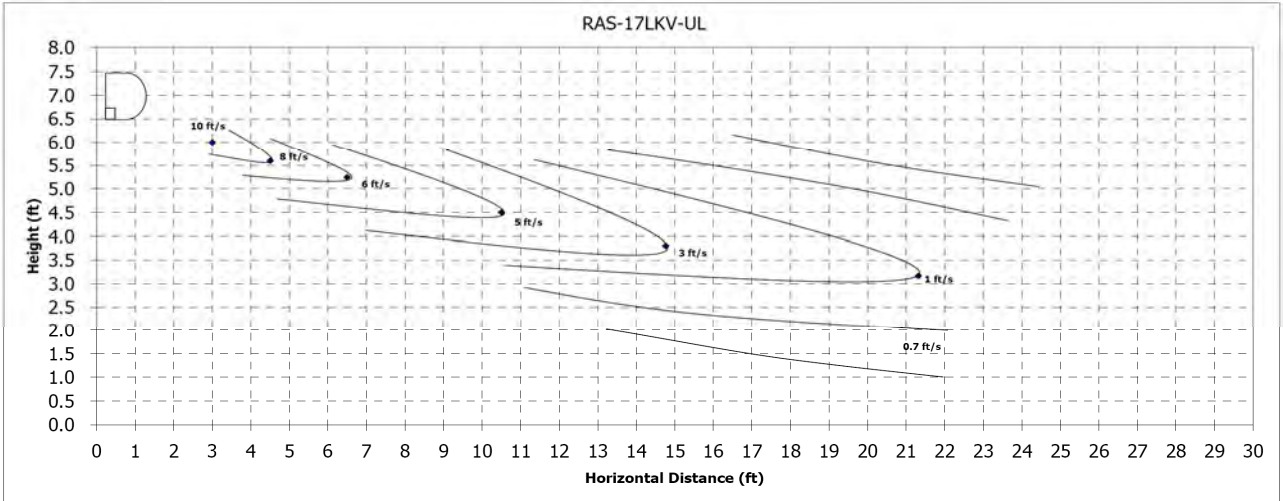

Heating

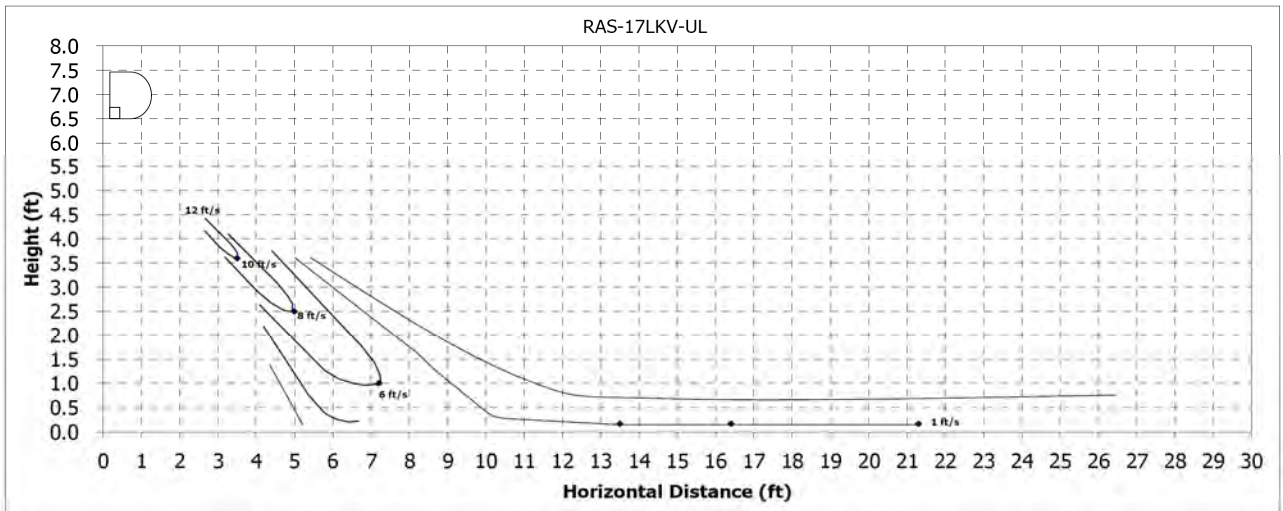

Air throw chart

Cooling

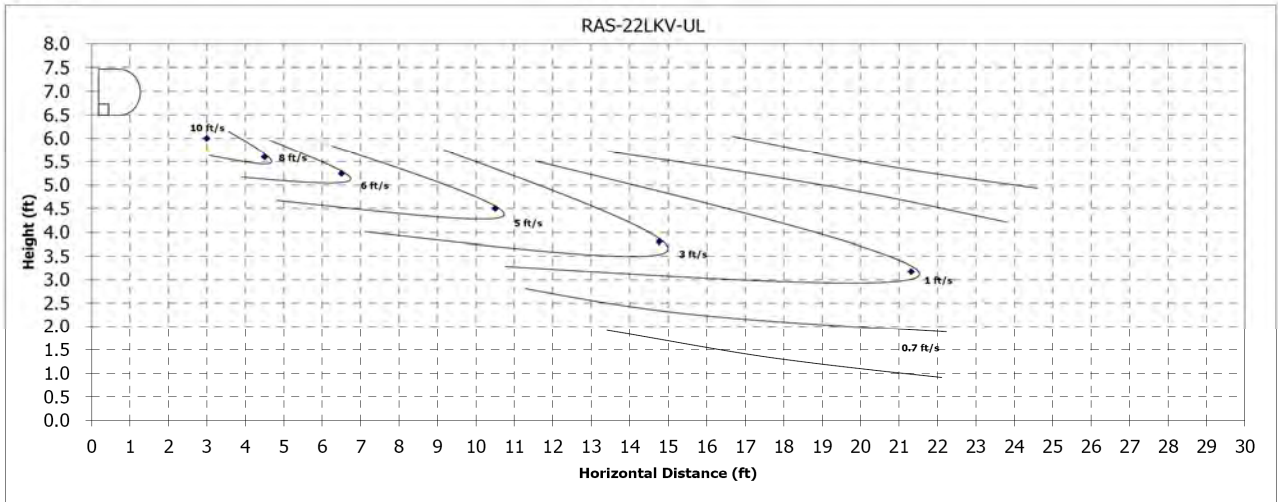

Heating

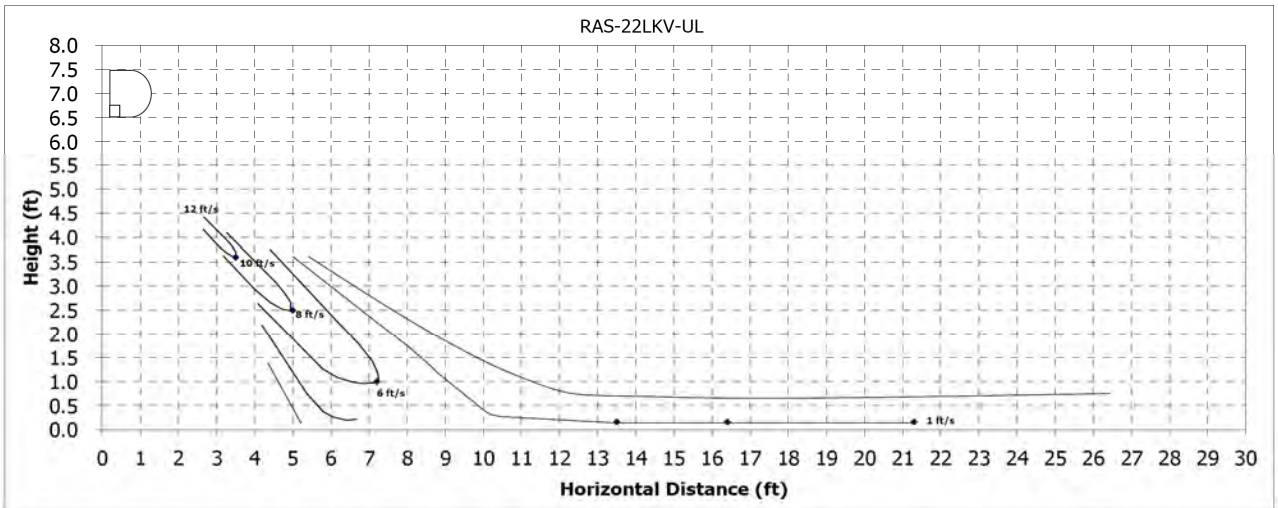

■ Indoor and outdoor sound characteristics

RAS-09LKV-UL

- Cooling operation

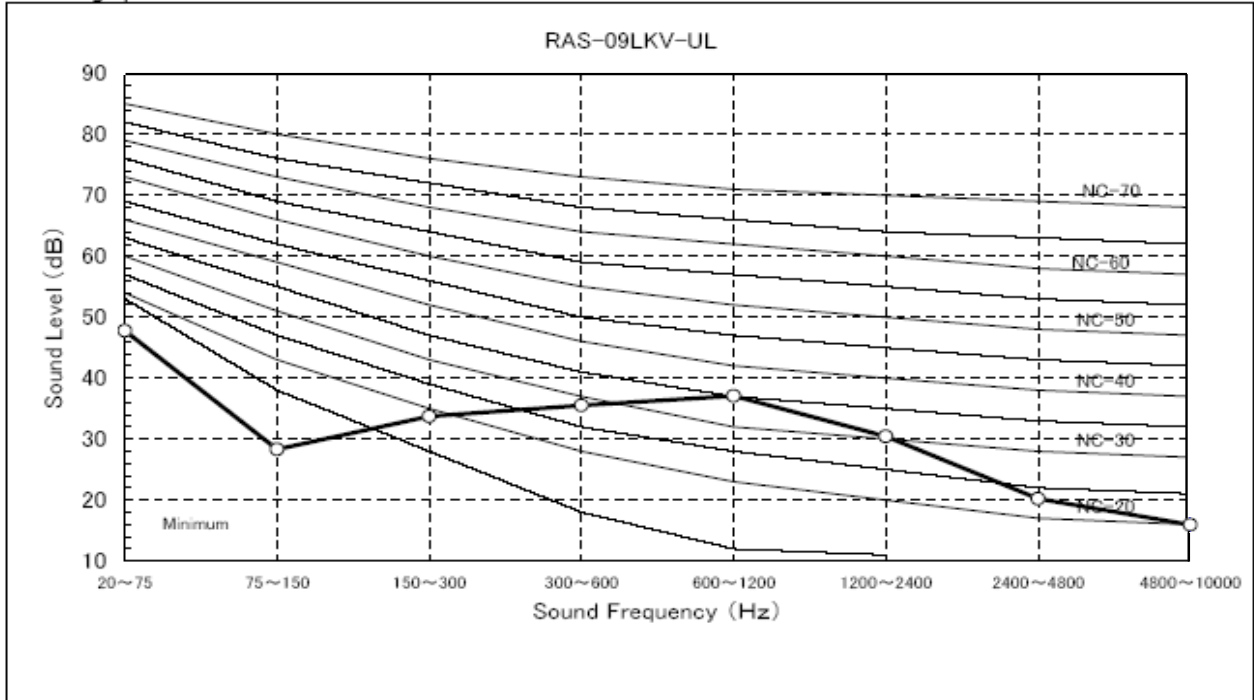

- Heating operation

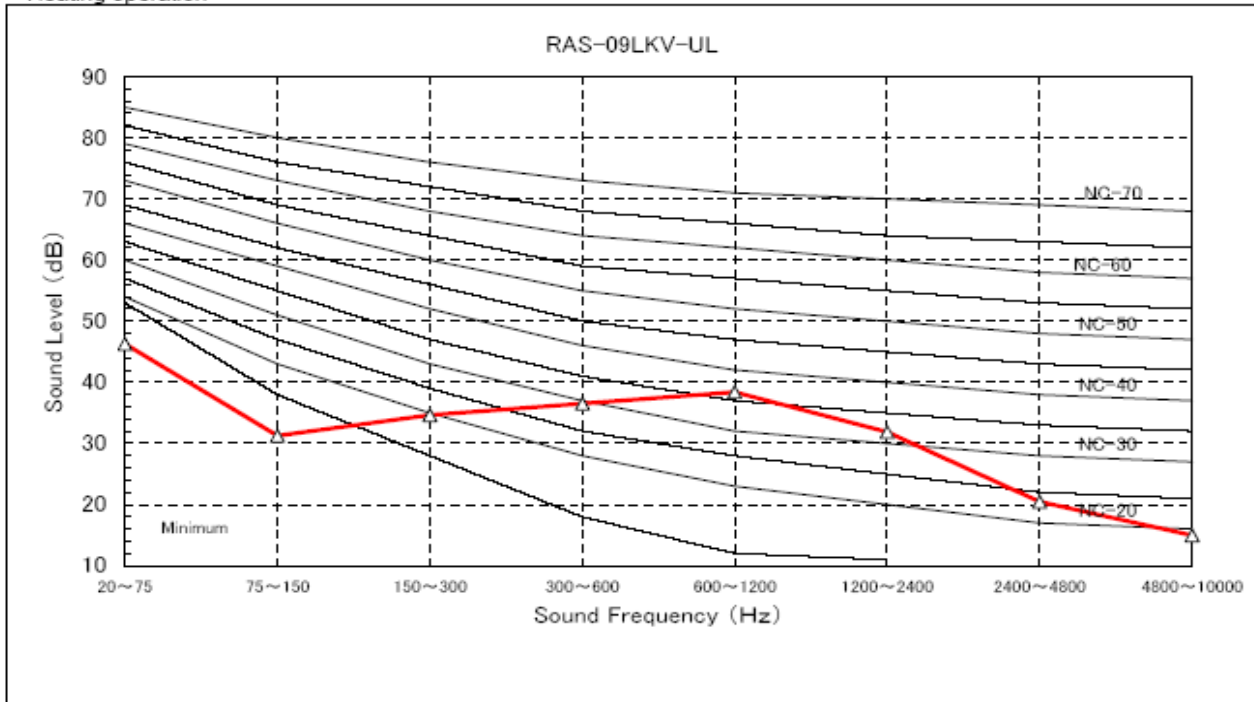

■ Indoor and outdoor sound characteristics

RAS-09LAV-UL

- Cooling operation

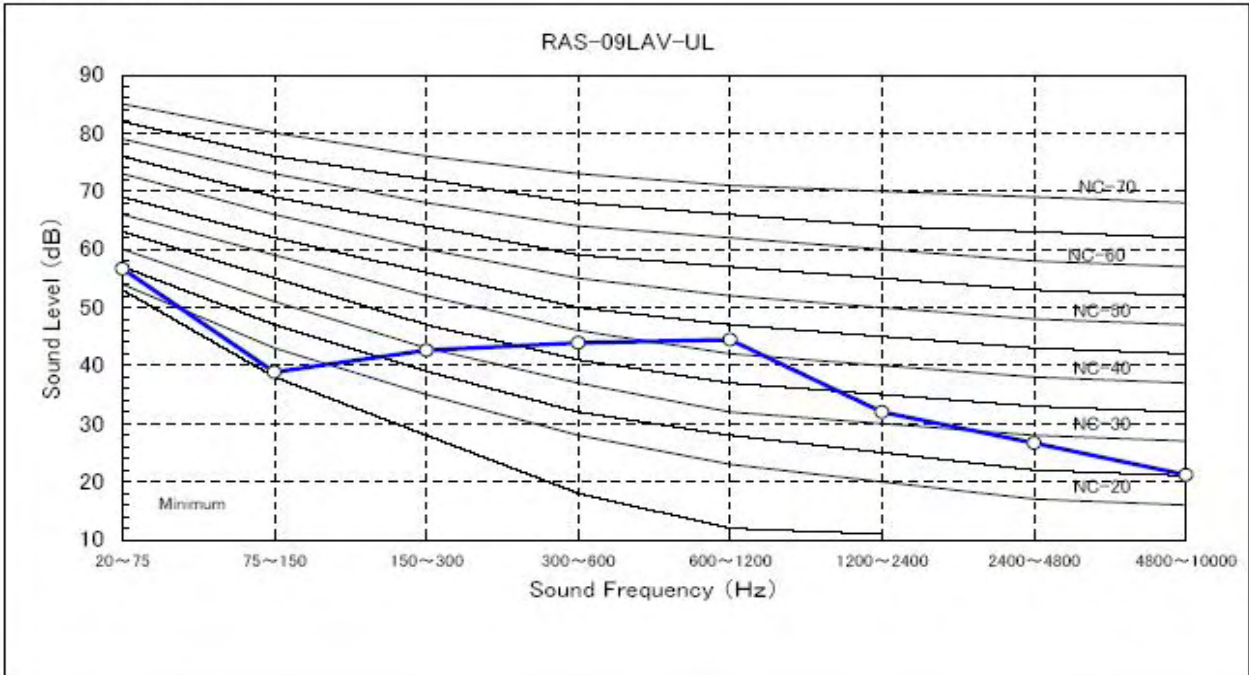

- Heating operation

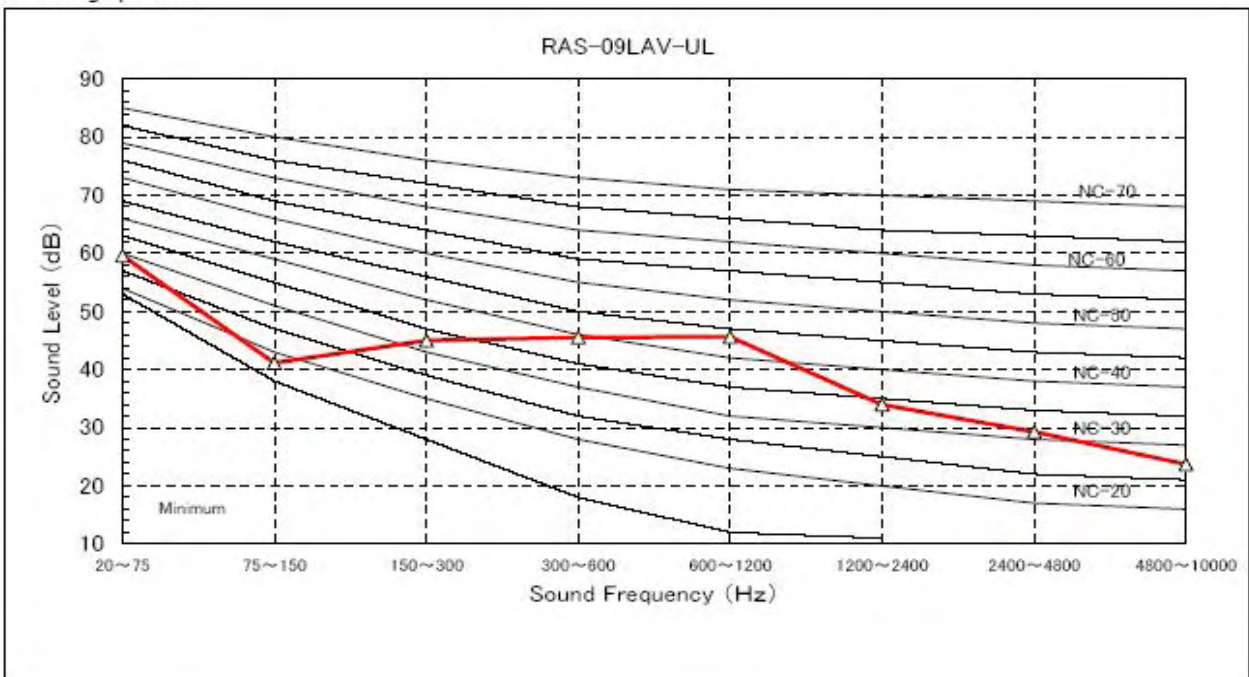

■ Indoor and outdoor sound characteristics

RAS-12LKV-UL

- Cooling operation

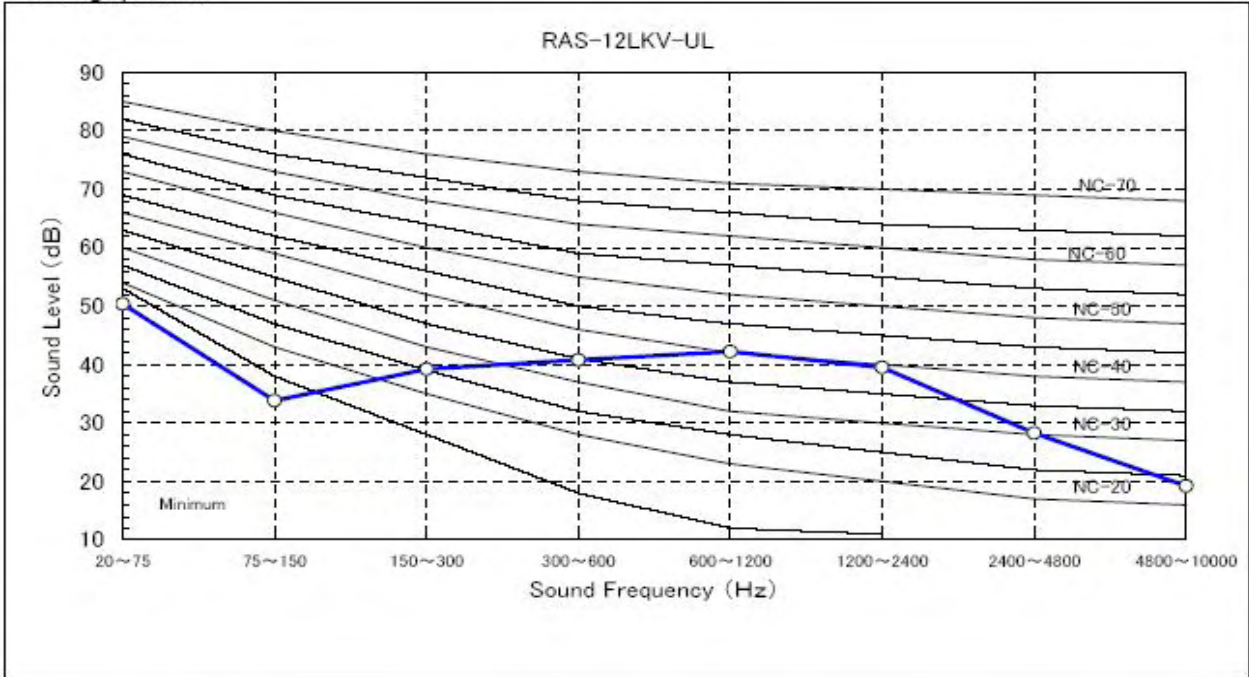

- Heating operation

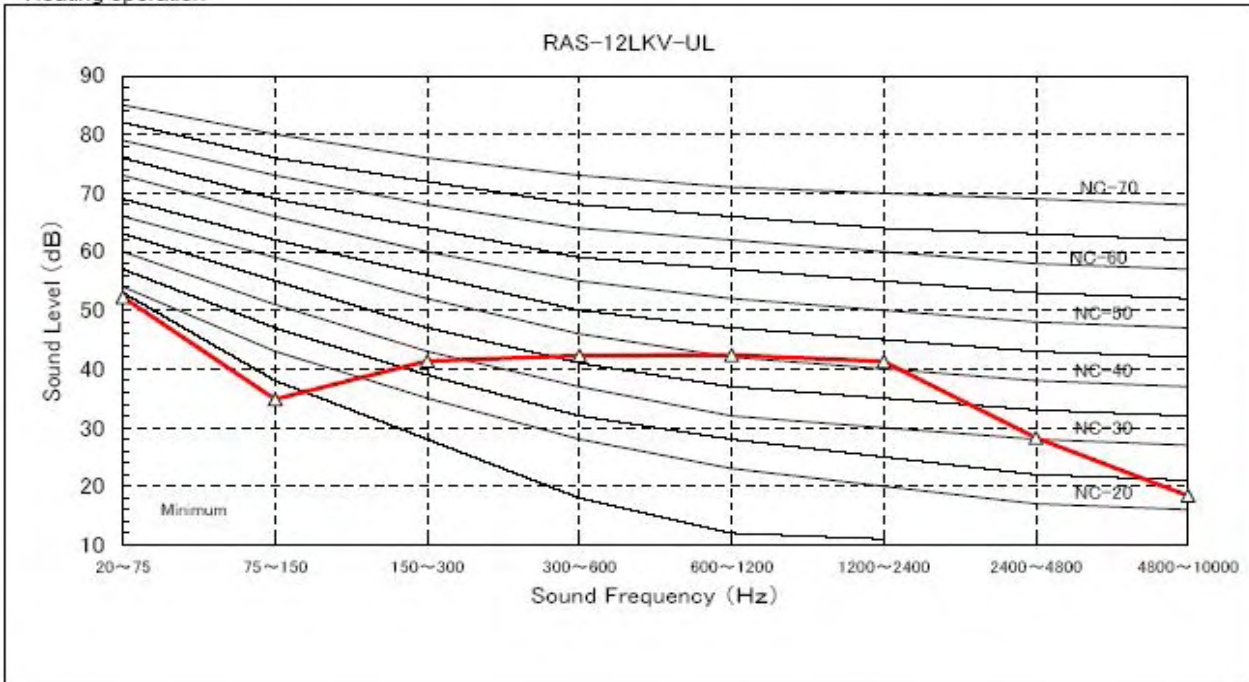

■ Indoor and outdoor sound characteristics

RAS-12LAV-UL

- Cooling operation

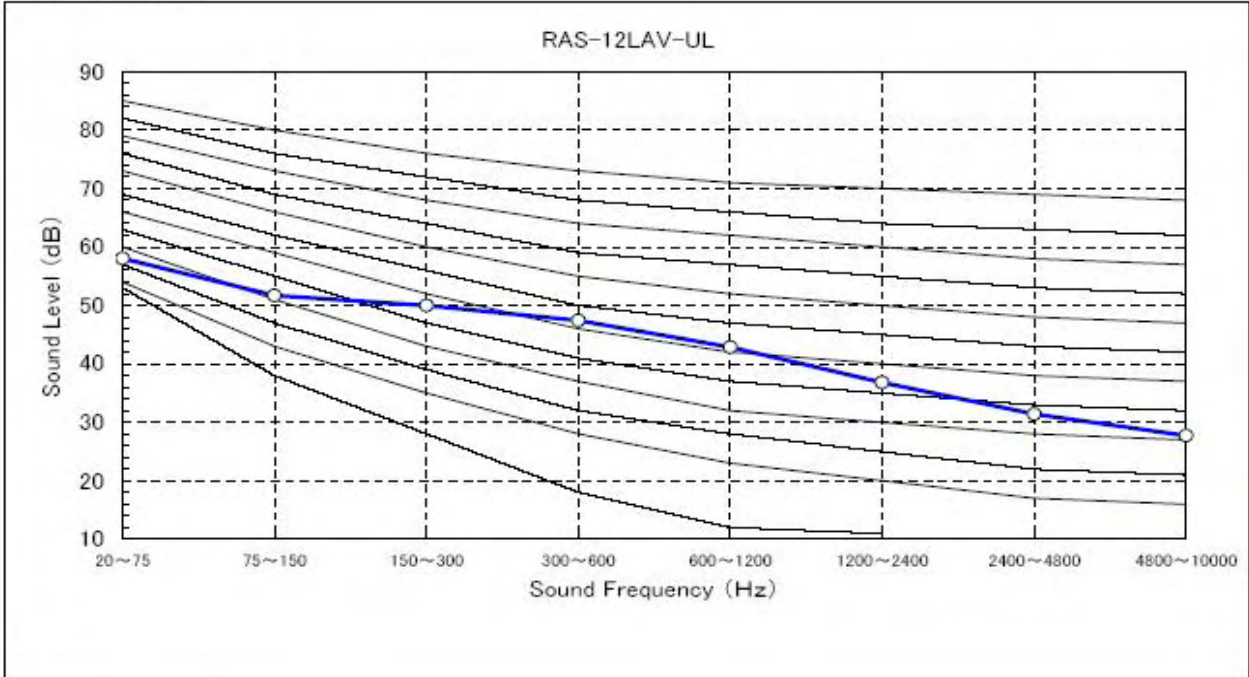

- Heating operation

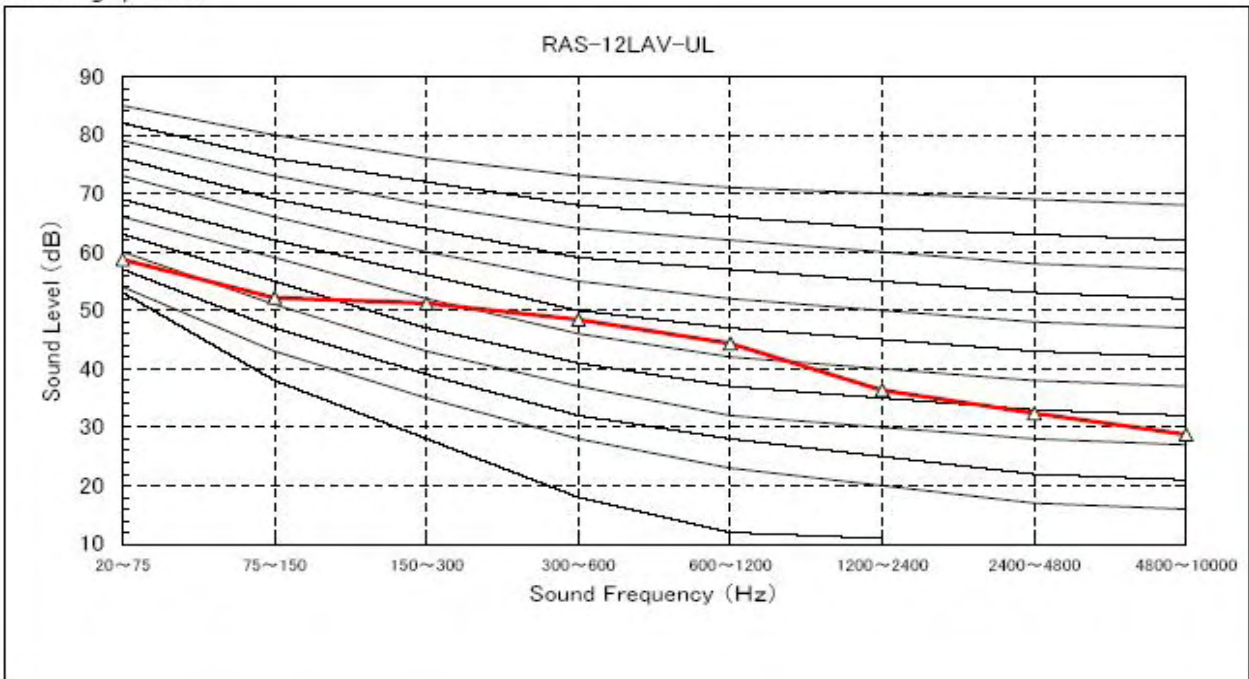

■ Indoor and outdoor sound characteristics

RAS-15LKV-UL

- Cooling operation

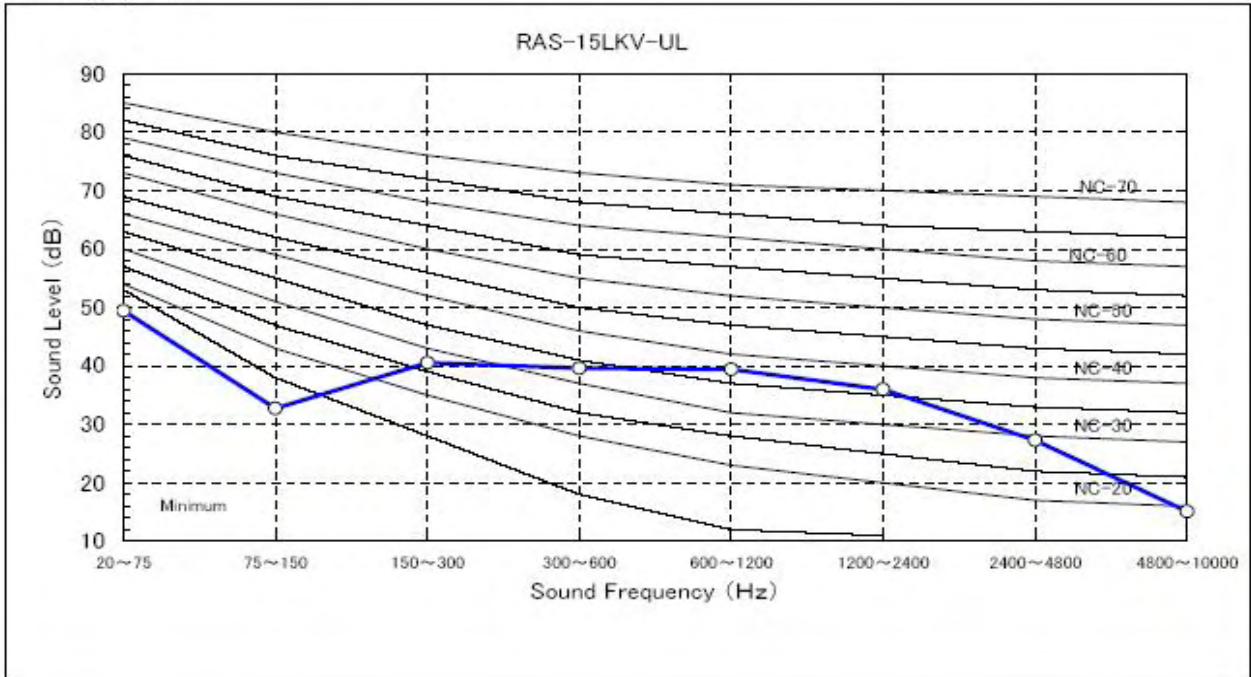

- Heating operation

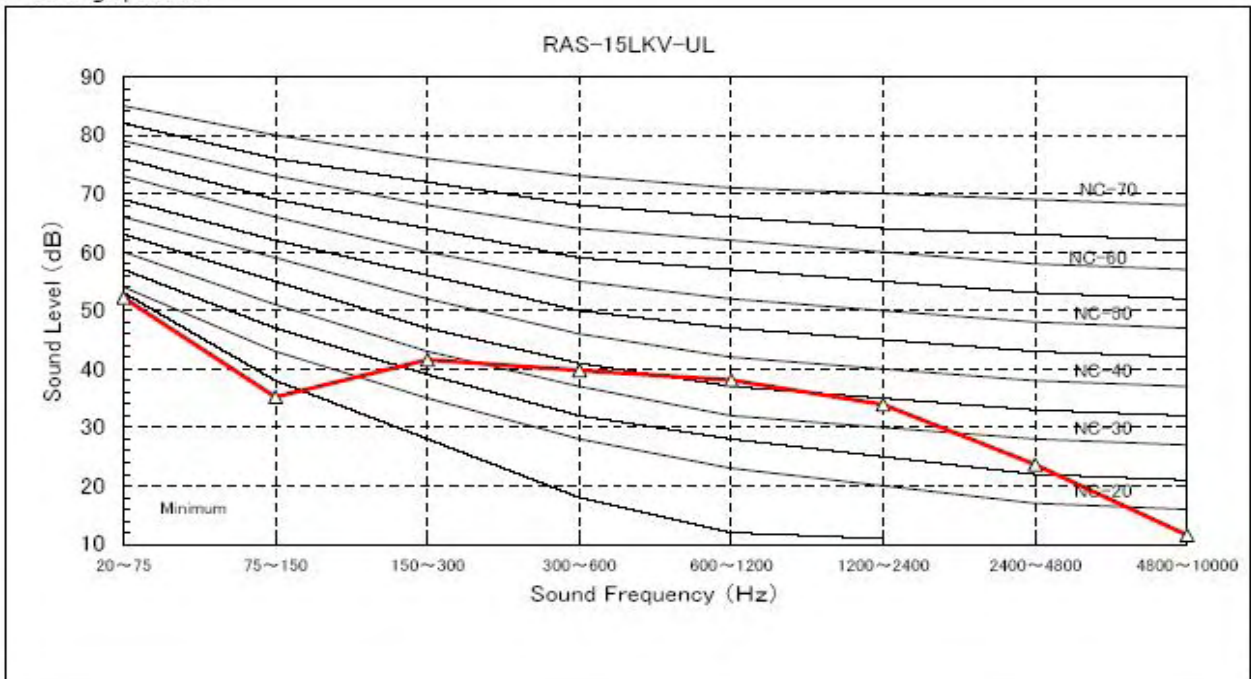

■ Indoor and outdoor sound characteristics

RAS-15LAV-UL

- Cooling operation

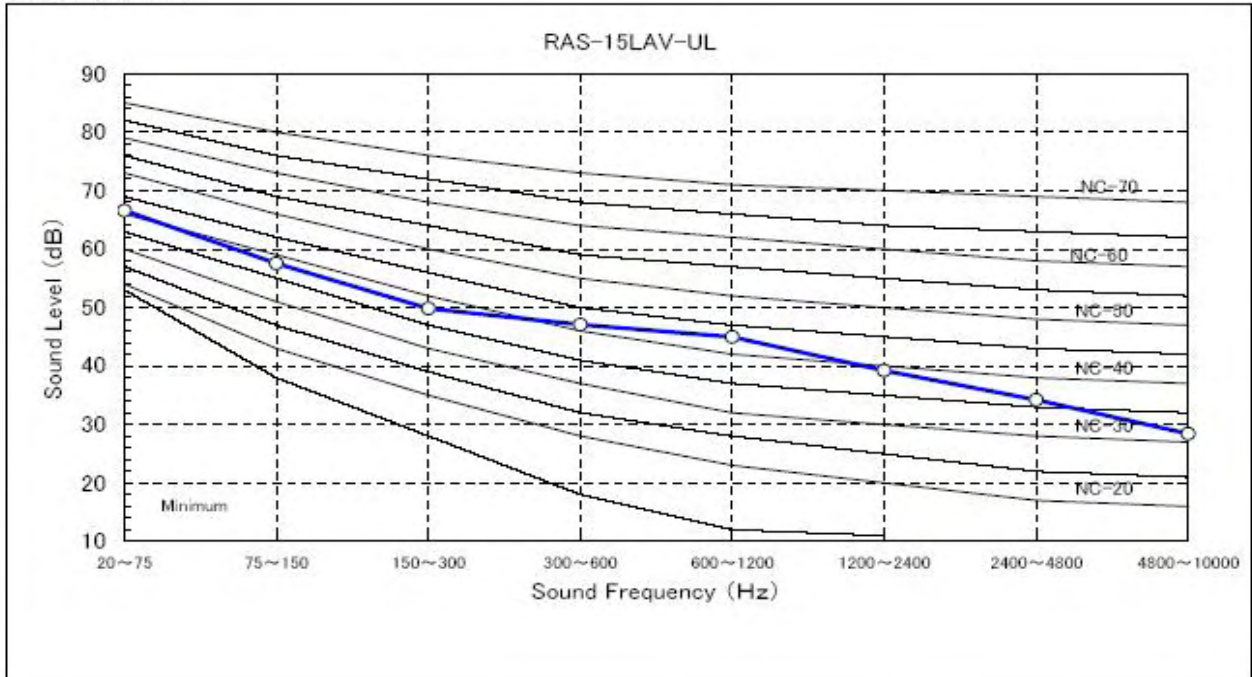

- Heating operation

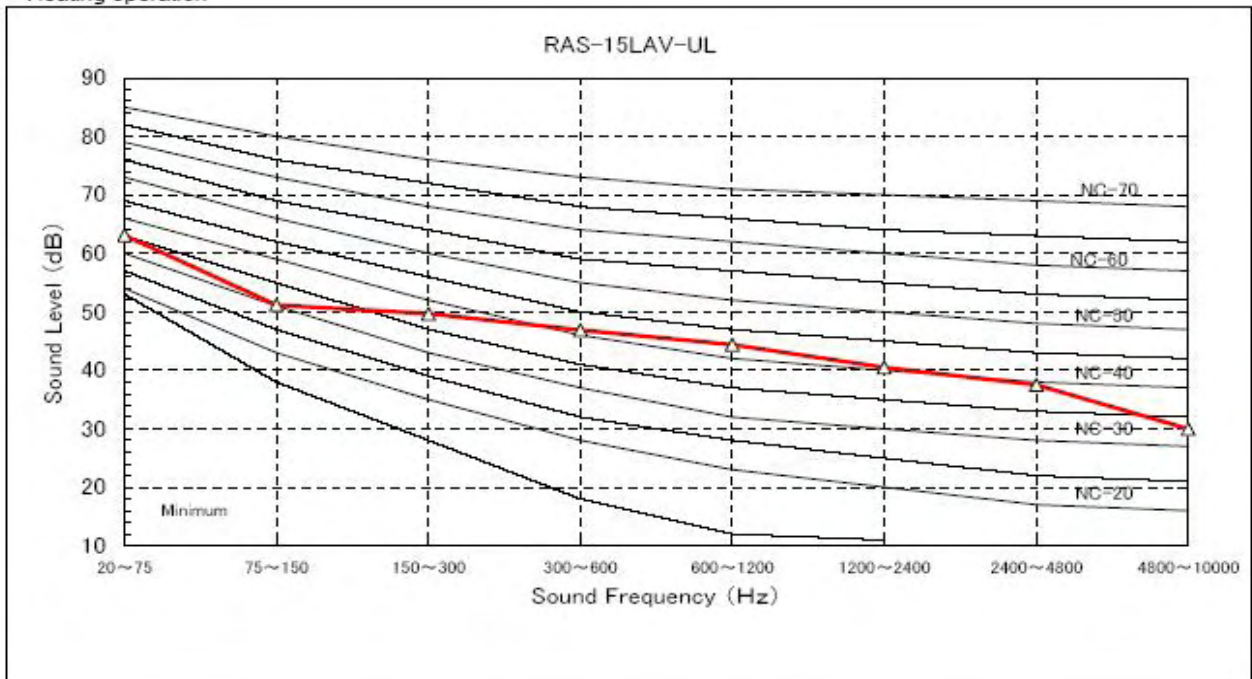

■ Indoor and outdoor sound characteristics

RAS-17LKV-UL

- Cooling operation

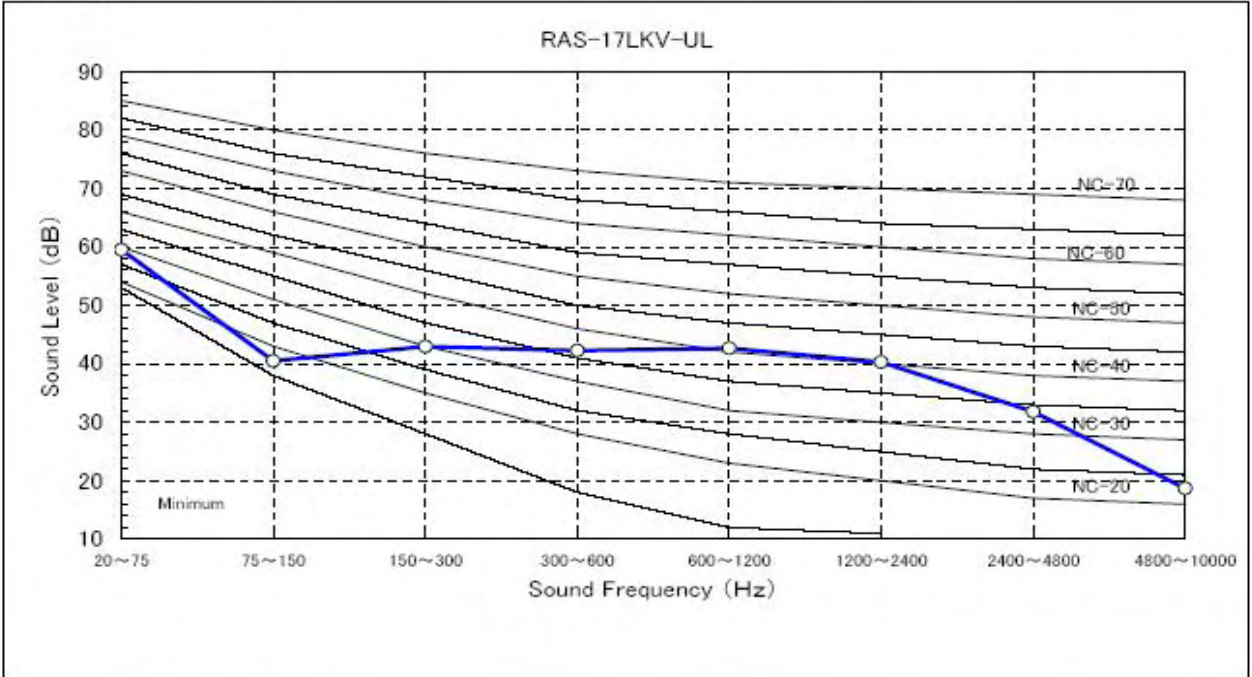

- Heating operation

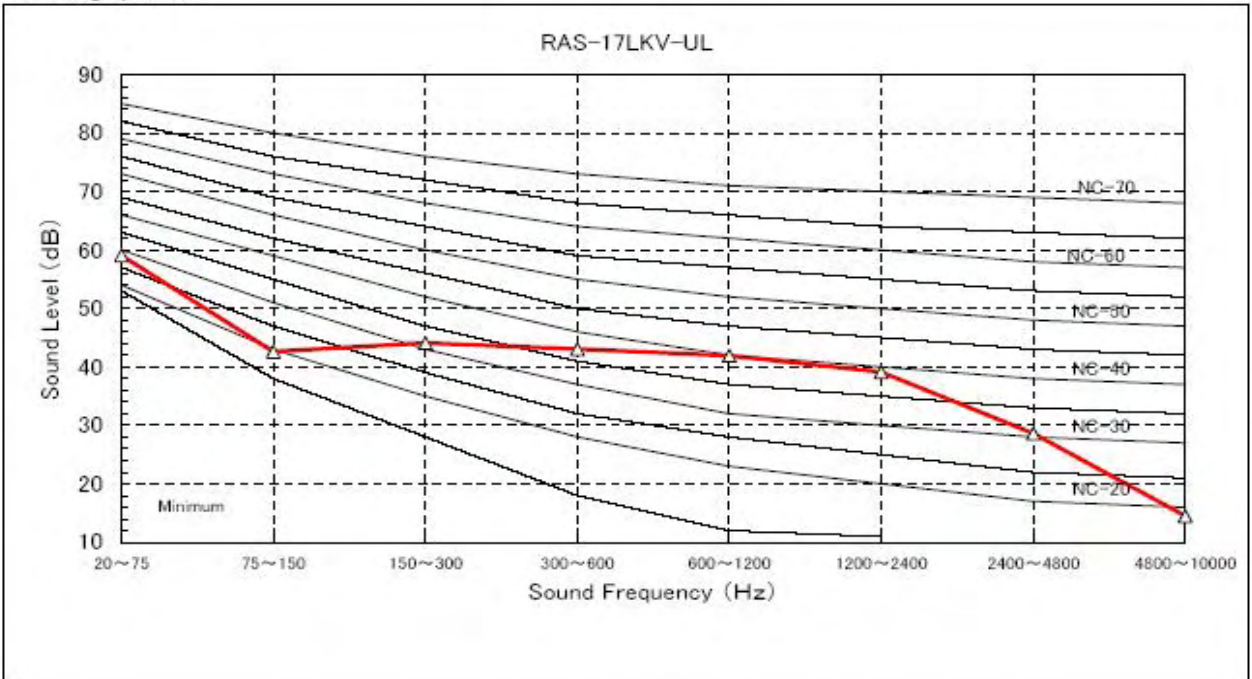

■ Indoor and outdoor sound characteristics

RAS-17LAV-UL

- Cooling operation

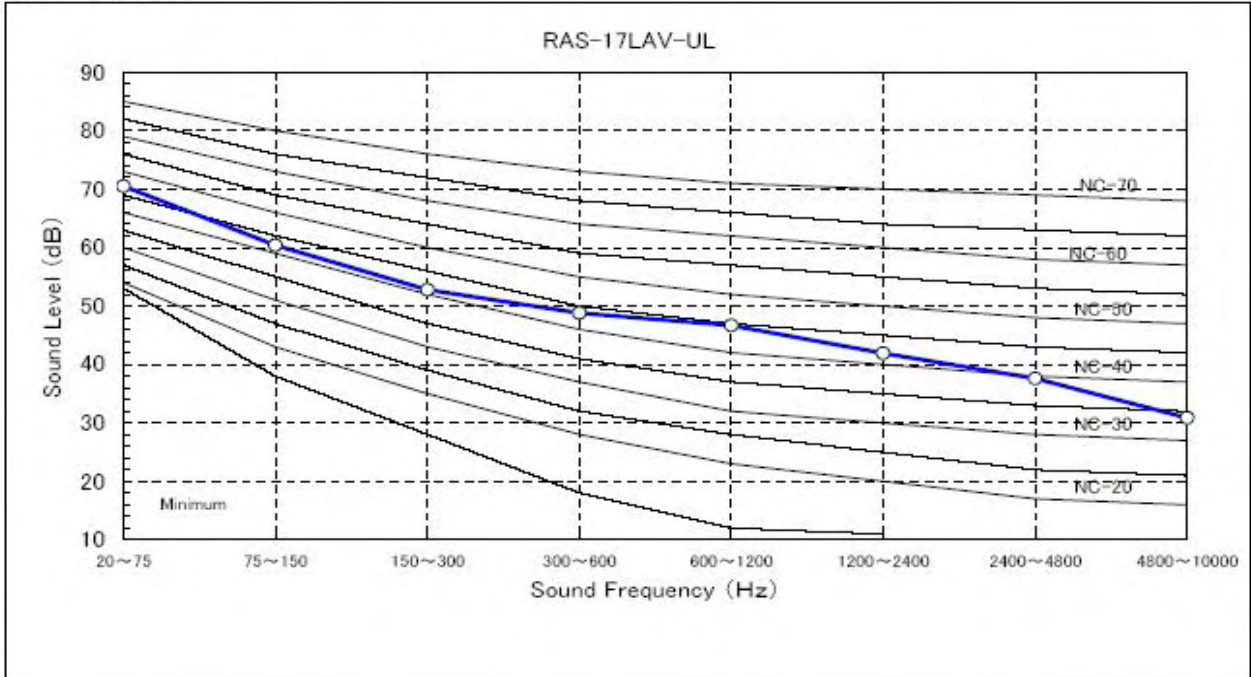

- Heating operation

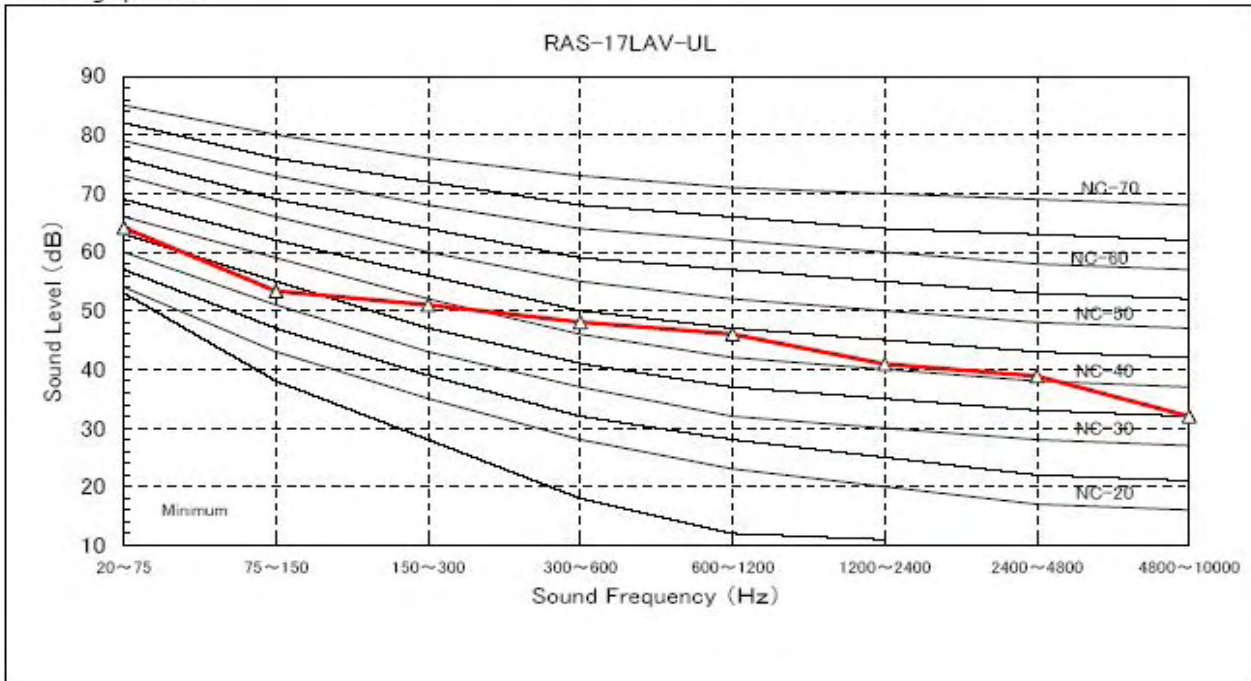

■ Indoor and outdoor sound characteristics

RAS-22LKV-UL

- Cooling operation

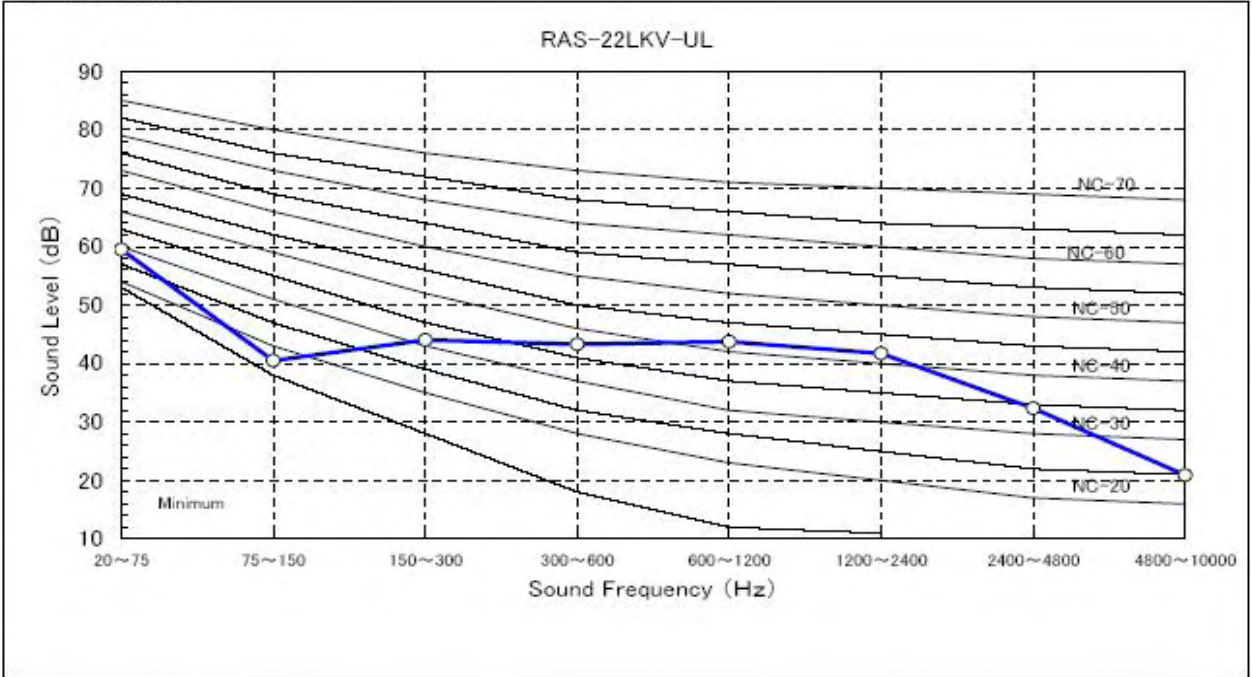

- Heating operation

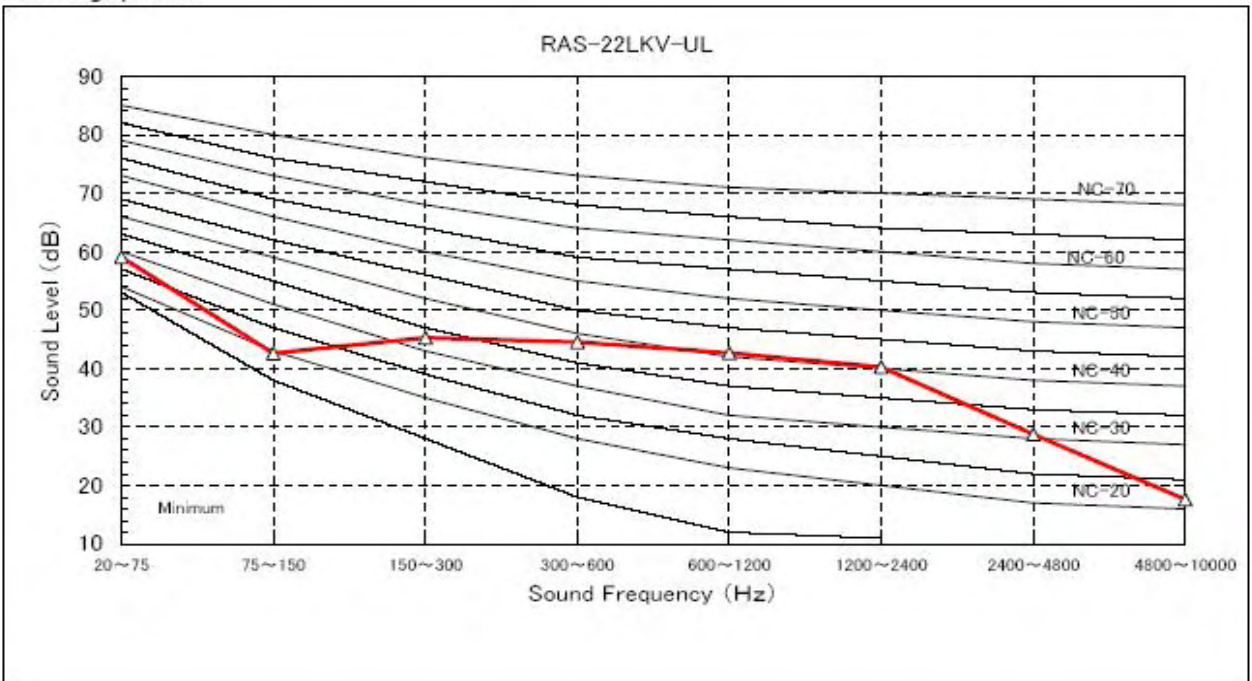

■ Indoor and outdoor sound characteristics

RAS-22LAV-UL

- Cooling operation

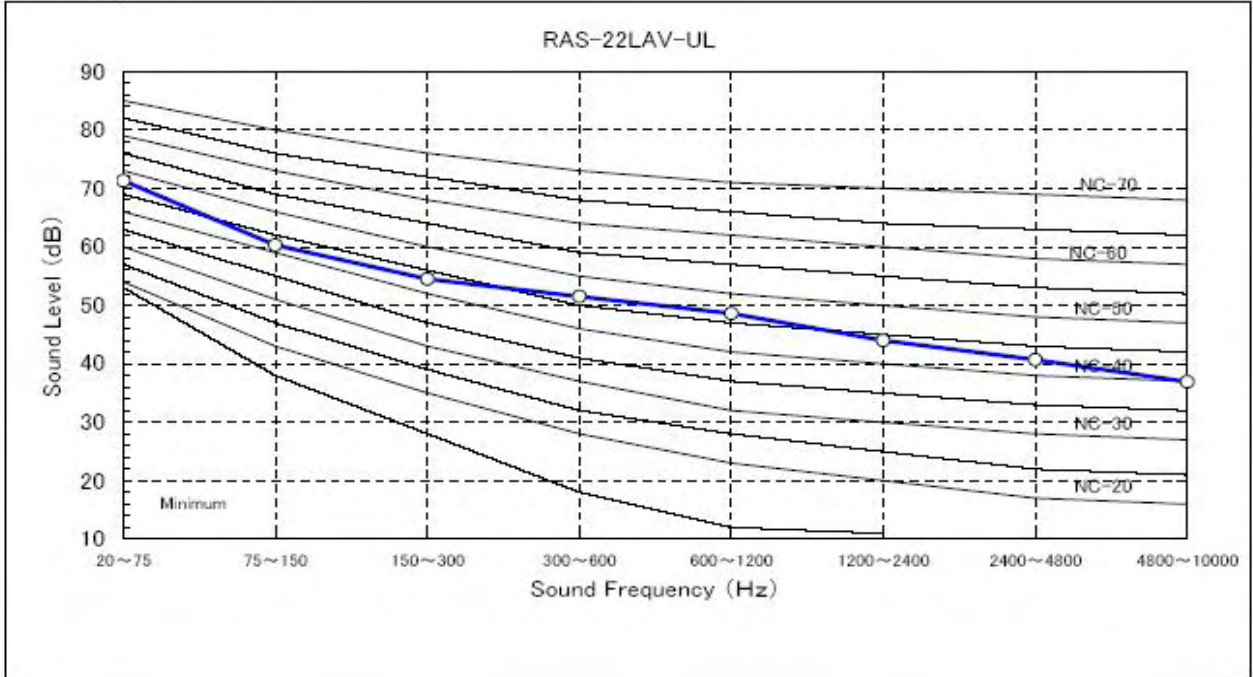

- Heating operation

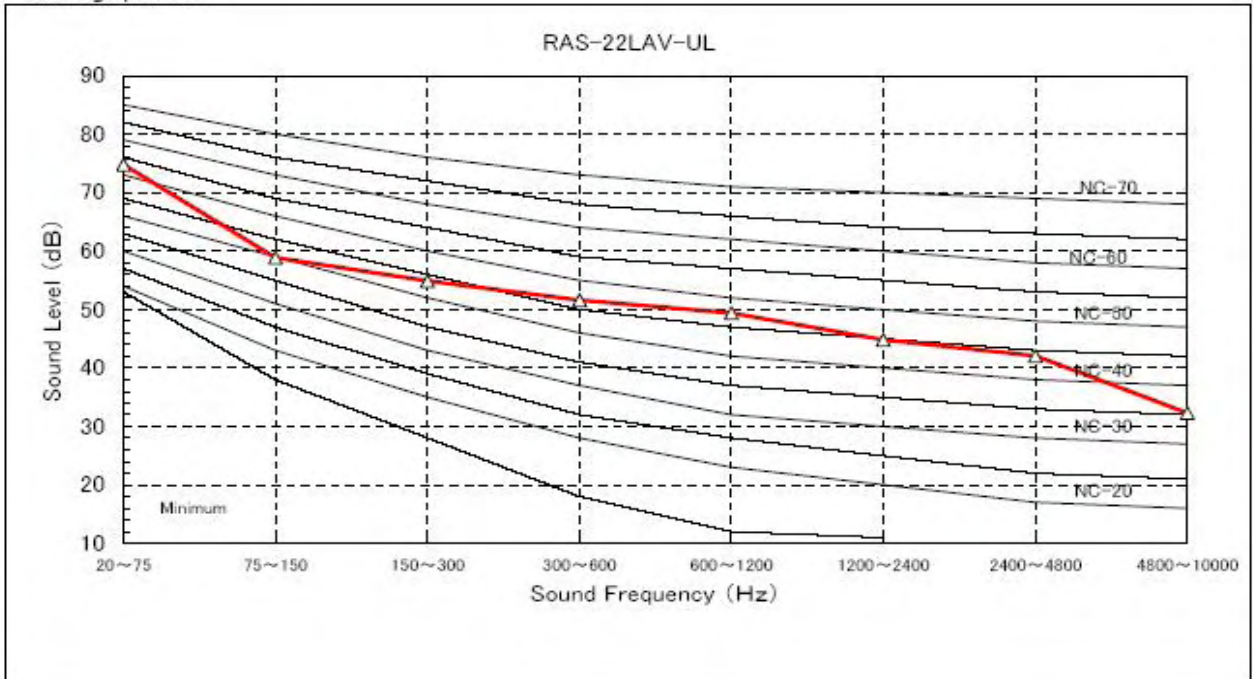

■ Wiring diagrams

RAS-09LKV-UL / RAS-09LAV-UL

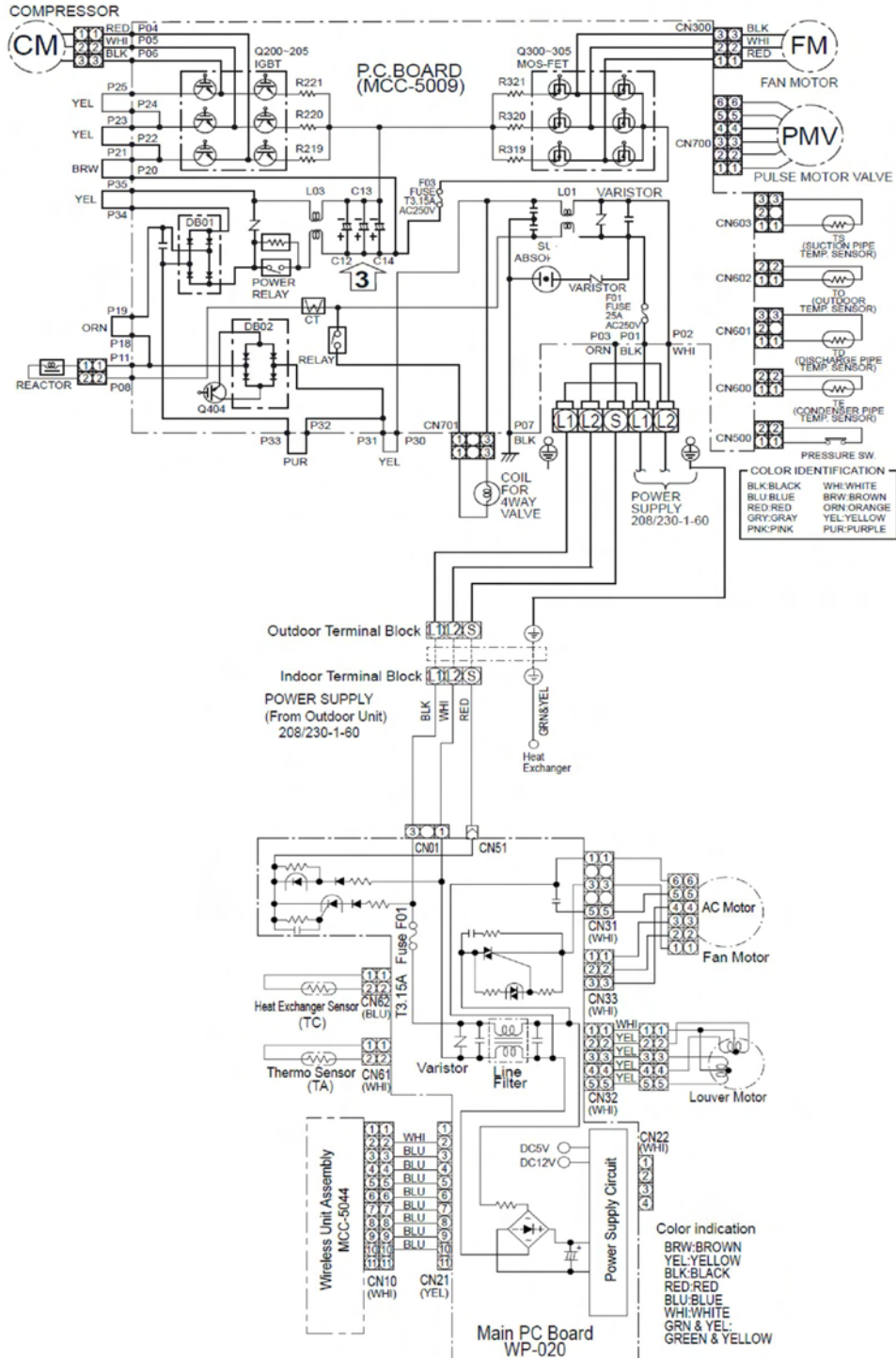

■ Wiring diagrams

RAS-12LKV-UL / RAS-12LAV-UL

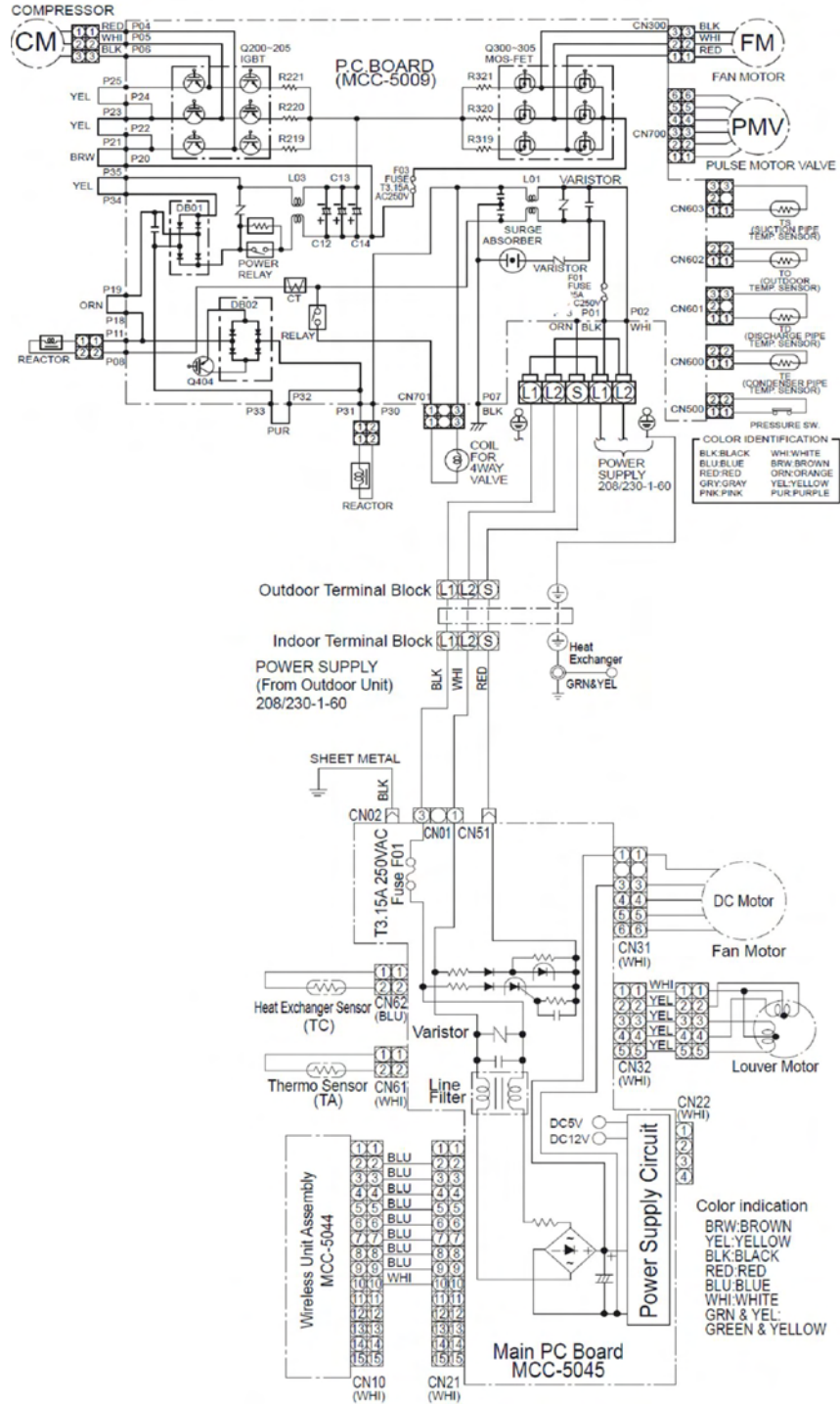

■ Wiring diagrams

RAS-15LKV-UL / RAS-15LAV-UL
RAS-17LKV-UL / RAS-17LAV-UL
RAS-22LKV-UL / RAS-22LAV-UL

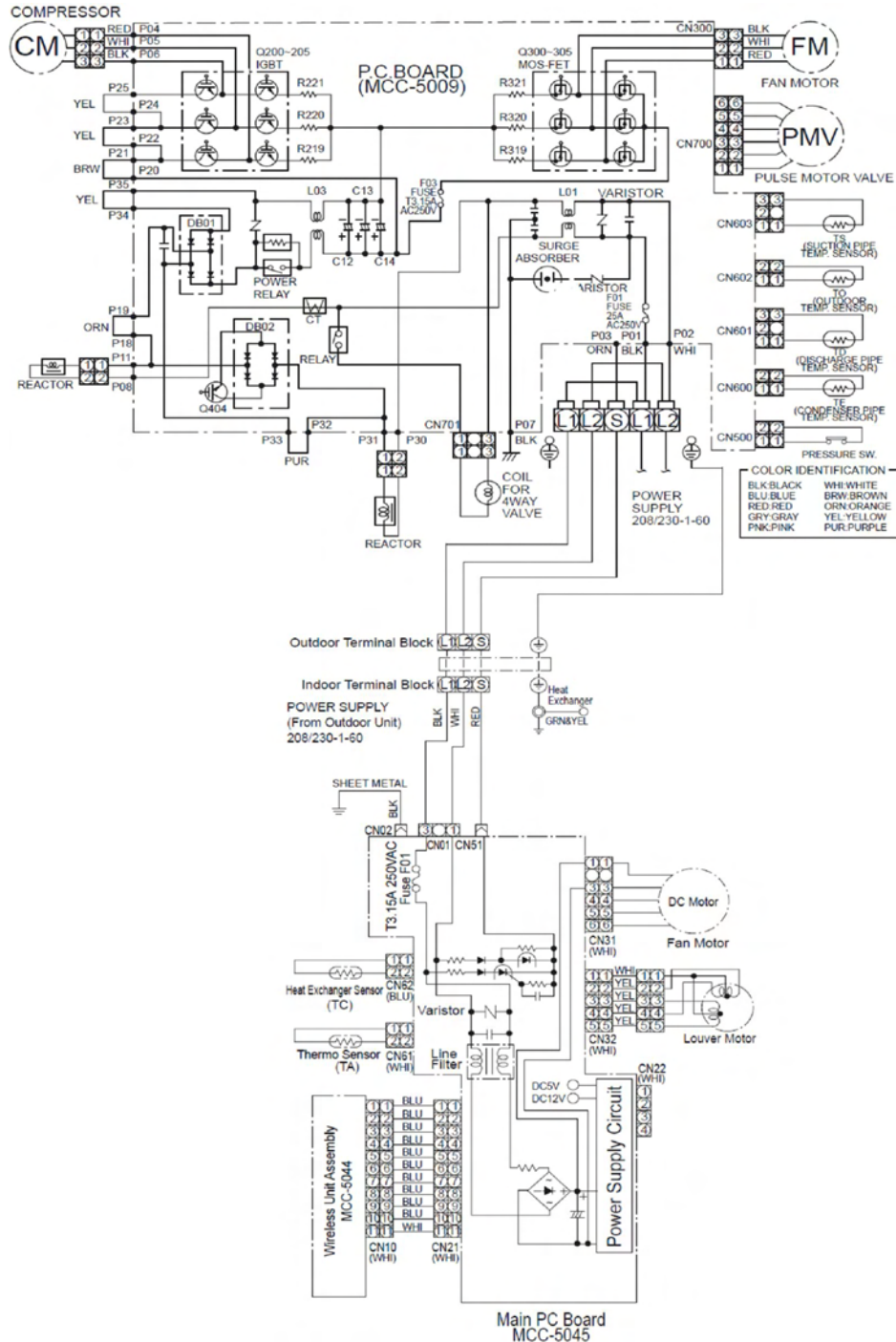

■ Remote control

